

2.5V and 4.096V Voltage References

DEVICE SELECTION TABLE

Part Number	Nominal Reference Voltage Output (V)	Input Voltage Range (V)
MCP1525	2.5	2.7 - 5.5
MCP1541	4.096	4.3 - 5.5

FEATURES

- Precision voltage reference
- Output voltages of 2.5V and 4.096V
- Initial accuracy of $\pm 1\%$ max.
- Temperature drift: ± 50 ppm/ $^{\circ}\text{C}$, max.
- Output current drive: $\pm 2\text{mA}$
- Max operating current: $100\ \mu\text{A}$ @ 25°C , max.
- TO-92, SOT23-3 packages
- Industrial temperature range: -40°C to $+85^{\circ}\text{C}$

APPLICATIONS

- Battery Powered Systems
- Handheld Instruments
- Instrumentation and Process Control
- Test Equipment
- Data Acquisition Systems
- Communications Equipment
- Medical Equipment
- Precision Power supplies
- 8-bit, 10-bit, 12-bit A/D Converters
- D/A Converters

DESCRIPTION

The Microchip Technology Inc. MCP1525 and MCP1541 devices are 2.5V and 4.096V precision voltage references that use a combination of an advanced CMOS circuit design and EPROM trimming to provide an initial tolerance of 1% (max) and temperature stability of 50 ppm/ $^{\circ}\text{C}$ (max). In addition to a low quiescent current of $100\ \mu\text{A}$ (max) at 25°C , these devices offer a clear advantage over the traditional zener techniques in terms of stability over time and temperature. The output voltage for the MCP1525 is 2.5V and 4.096V for the MCP1541. These devices are offered in SOT23-3 and TO-92 packages and are specified over the industrial temperature range of -40°C to $+85^{\circ}\text{C}$.

PACKAGES

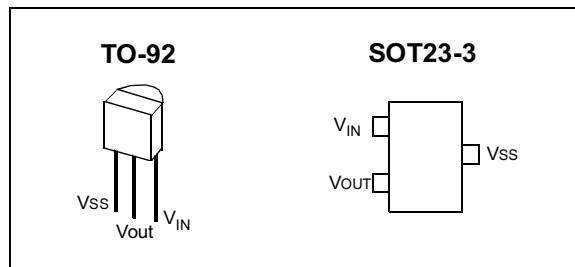

MCP1541 TEMPERATURE DRIFT

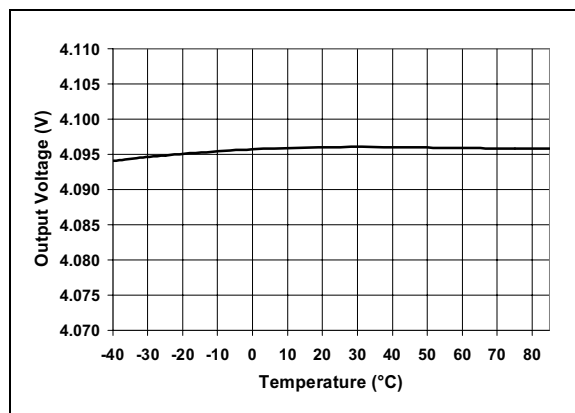

MCP1525/1541

1.0 ELECTRICAL SPECIFICATIONS

1.1 Maximum Ratings*

V_{IN}	7.0V
Input Current (V_{IN})	20 mA
Output current (V_{OUT})	± 20 mA
Continuous Power Dissipation ($T_A = 125^\circ\text{C}$)	140 mW
All inputs and outputs w.r.t.	-0.6V to ($V_{IN} + 1.0\text{V}$)
Storage temperature	-65°C to $+150^\circ\text{C}$
Ambient temp. with Input voltage applied	-55°C to $+125^\circ\text{C}$
ESD protection on all pins.....	≥ 4 kV

***Notice:** Stresses above those listed under "Maximum Ratings" may cause permanent damage to the device. This is a stress rating only and functional operation of the device at those or any other conditions above those indicated in the operational listings of this specification is not implied. Exposure to maximum rating conditions for extended periods may affect device reliability.

ELECTRICAL CHARACTERISTICS

All parameters apply at $V_{IN} = 5\text{V}$, $I_{OUT} = 0$ mA, $T_A = 25^\circ\text{C}$, unless otherwise noted.							
Parameter		Symbol	Min	Typ	Max	Units	Conditions
Output Voltage	MCP1525	V_{OUT}	2.475	2.5	2.525	V	$2.7 \leq V_{IN} \leq 5.5$
	MCP1541		4.055	4.096	4.137	V	$4.3 \leq V_{IN} \leq 5.5$
Operating Voltage	MCP1525	V_{IN}	2.7	—	5.5	V	$T_A = -40^\circ\text{C}$ to 85°C
	MCP1541		4.3	—	5.5	V	$T_A = -40^\circ\text{C}$ to 85°C
Output Voltage Drift ⁽²⁾		TCV_{OUT}	—	27	50	ppm/ $^\circ\text{C}$	$T_A = -40^\circ\text{C}$ to 85°C
Dropout voltage		V_{DROP}	—	137	—	mV	$I_{OUT} = 2$ mA
MCP1525 Output Voltage Noise		e_N	—	90	—	$\mu\text{Vp-p}$	0.1 Hz to 10 Hz
			—	500	—		10 Hz to 10 kHz
MCP1541 Output Voltage Noise		e_N	—	145	—	$\mu\text{Vp-p}$	0.1 Hz to 10 Hz
			—	700	—		10Hz to 10 kHz
Line Regulation		$\frac{\Delta V_{OUT}}{\Delta V_{IN}}$	—	107	300	$\mu\text{V/V}$	$V_{IN} = 2.7\text{V}$ to 5.5V for MCP1525, $V_{IN} = 4.3\text{V}$ to 5.5V for MCP1541
		$\frac{\Delta V_{OUT}}{\Delta V_{IN}}$	—	—	350	$\mu\text{V/V}$	$V_{IN} = 2.7\text{V}$ to 5.5V for MCP1525, $V_{IN} = 4.3\text{V}$ to 5.5V for MCP1541, $T_A = -40^\circ\text{C}$ to 85°C
Load Regulation		$\frac{\Delta V_{OUT}}{\Delta I_{OUT}}$	—	0.5	1	mV/mA	$I_{OUT} = 0$ mA to -2 mA
		$\frac{\Delta V_{OUT}}{\Delta I_{OUT}}$	—	0.6	1		$I_{OUT} = 0$ mA to 2 mA
		$\frac{\Delta V_{OUT}}{\Delta I_{OUT}}$	—	—	1.3	mV/mA	$I_{OUT} = 0$ mA to -2 mA, $T_A = -40^\circ\text{C}$ to 85°C
		$\frac{\Delta V_{OUT}}{\Delta I_{OUT}}$	—	—	1.3		$I_{OUT} = 0$ mA to 2 mA, $T_A = -40^\circ\text{C}$ to 85°C
Output Voltage Hysteresis ⁽¹⁾		V_{HYS}	—	115	—	ppm	
Maximum Load Current		I_{SC}	—	± 8	—	mA	$T_A = -40^\circ\text{C}$ to 85°C , $V_{IN} = 5.5\text{V}$
Long Term Output Stability		V_{OUT}	—	2	—	ppm/h	Exposed 1008 hrs @ 125°C (see Figure 4-1), measured @ 25°C
Input Current		I_{IN}	—	86	100	μA	no load
			—	95	120	μA	no load, $T_A = -40^\circ\text{C}$ to 85°C
Temperature Ranges:							
Specified Temperature Range		T_A	-40	—	+85	$^\circ\text{C}$	
Operating Temperature Range		T_A	-40	—	+85	$^\circ\text{C}$	
Storage Temperature Range		T_A	-65	—	+150	$^\circ\text{C}$	
Thermal Package Resistance:							
Thermal Resistance, TO-92		θ_{JA}	—	132	—	$^\circ\text{C/W}$	
Thermal Resistance, SOT23-3		θ_{JA}	—	336	—	$^\circ\text{C/W}$	

Note 1: Output Voltage Hysteresis is defined as the change in output voltage measured at 25°C before and after cycling the temperature to 85°C and -40°C per Section 4.0.10.

2: Output temperature coefficient is measured using a "box" method where the 25°C output voltage is trimmed as close to typical as possible, then the 85°C output voltage is again trimmed to zero out the tempco.

2.0 TYPICAL PERFORMANCE CURVES

Note: Unless otherwise indicated, $V_{IN} = 5V$, $I_{OUT} = 0\text{ mA}$, $C_L = 1\text{ }\mu\text{F}$, $T_A = 25^\circ\text{C}$

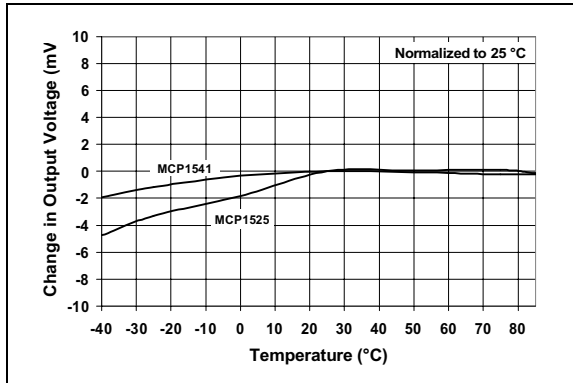

FIGURE 2-1: Change in Output Voltage vs. Temperature.

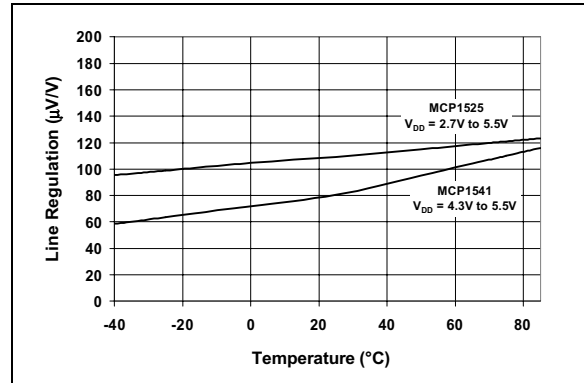

FIGURE 2-4: Line Regulation vs. Temperature.

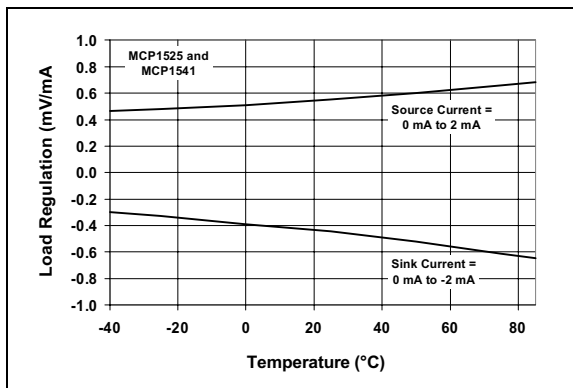

FIGURE 2-2: Load Regulation vs. Temperature.

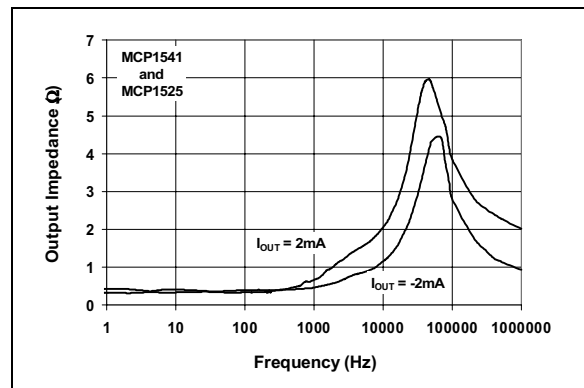

FIGURE 2-5: Output Impedance vs. Frequency.

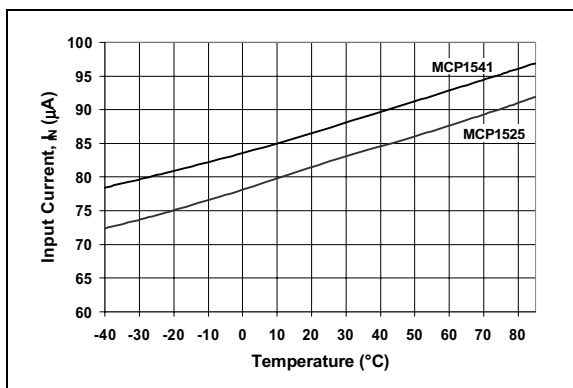

FIGURE 2-3: Input Current vs. Temperature.

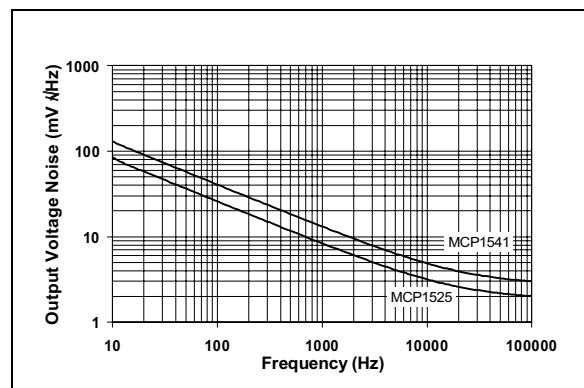

FIGURE 2-6: Output Voltage Noise vs. Frequency.

MCP1525/1541

Note: Unless otherwise indicated, $V_{IN} = 5V$, $I_{OUT} = 0\text{ mA}$, $C_L = 1\ \mu F$, $T_A = 25^\circ C$

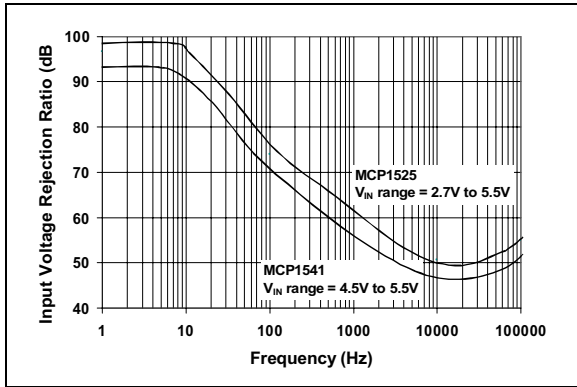

FIGURE 2-7: Input Voltage Rejection Ratio vs. Frequency.

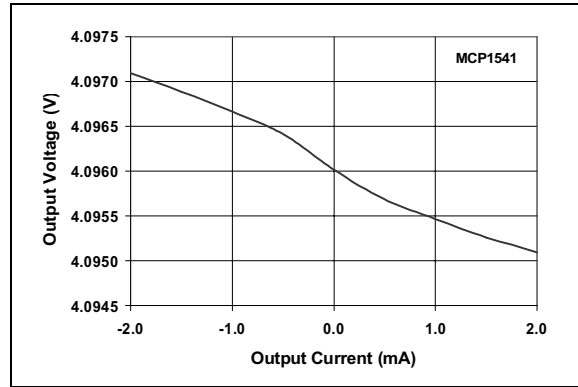

FIGURE 2-10: MCP1541 Output Voltage vs. Output Current.

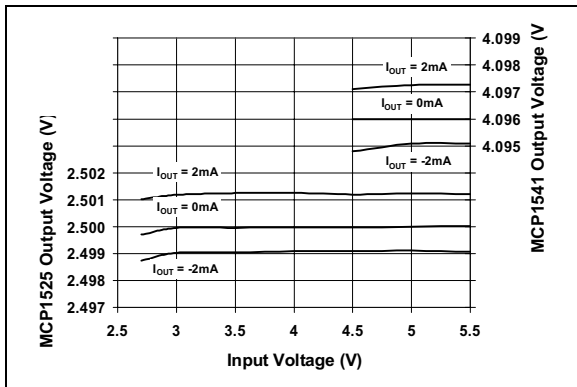

FIGURE 2-8: Output Voltage vs. Input Voltage.

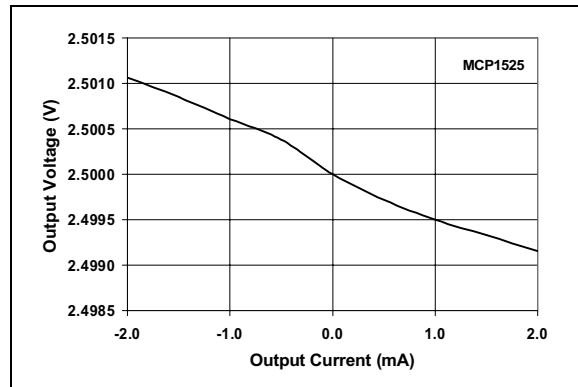

FIGURE 2-11: MCP1525 Output Voltage vs. Output Current.

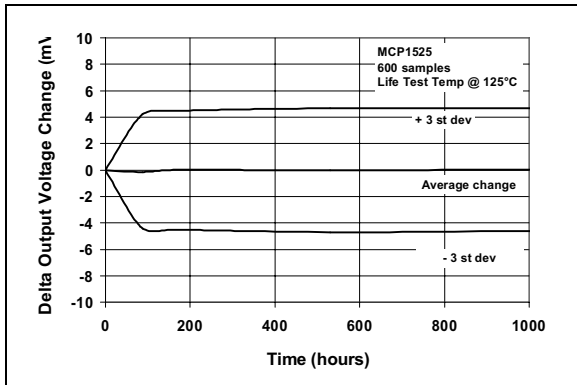

FIGURE 2-9: Delta Output Voltage Change vs. Time (DLT Data).

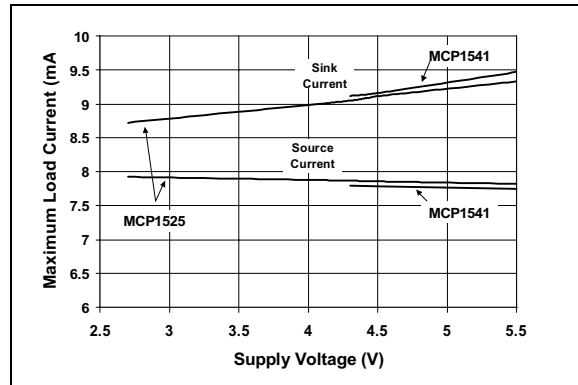

FIGURE 2-12: Maximum Load Current vs. Input Voltage.

MCP1525/1541

Note: Unless otherwise indicated, $V_{IN} = 5V$, $I_{OUT} = 0\text{ mA}$, $C_L = 1\ \mu\text{F}$, $T_A = 25^\circ\text{C}$

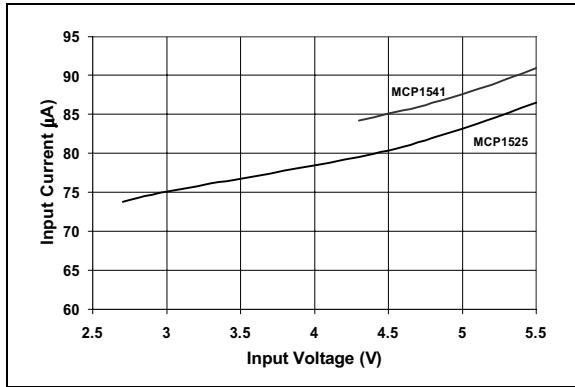

FIGURE 2-13: Input Current vs. Input Voltage.

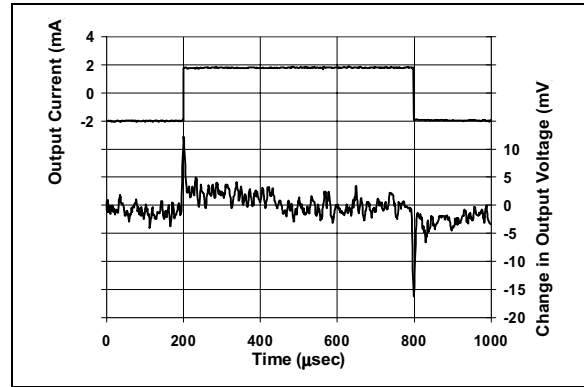

FIGURE 2-16: MCP1525 Load Transient Response.

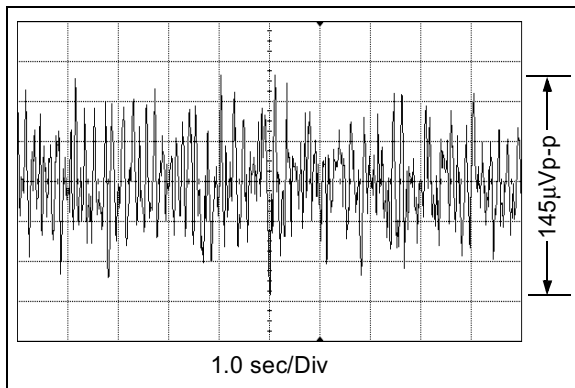

FIGURE 2-14: MCP1541 0.1 Hz to 10 Hz Output Noise.

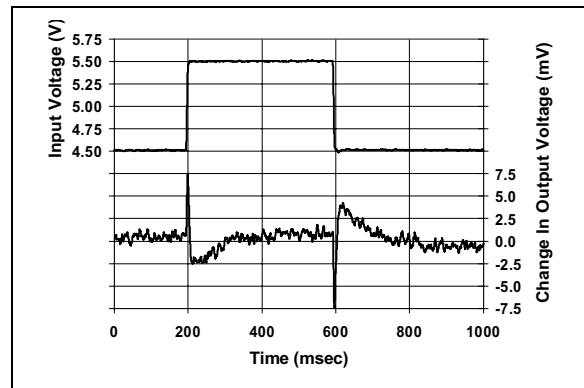

FIGURE 2-17: MCP1525 Line Transient Response.

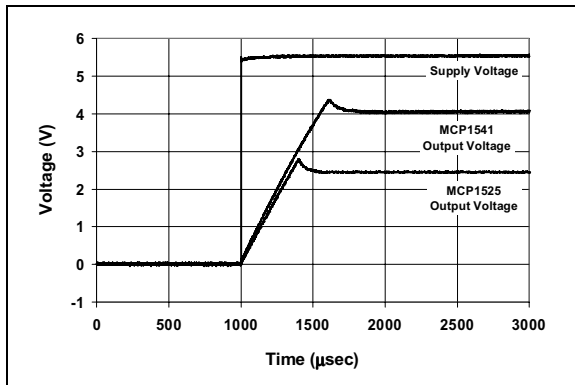

FIGURE 2-15: Turn-on Transient Time.

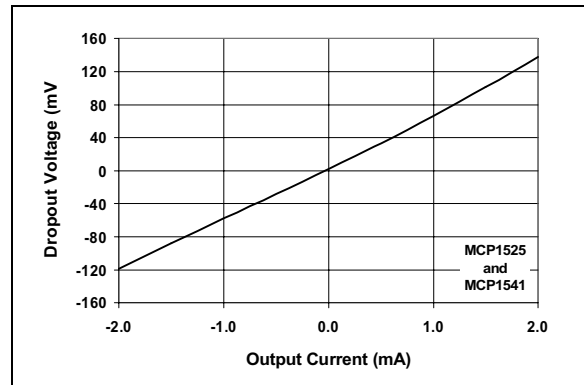

FIGURE 2-18: Dropout Voltage vs. Output Current.

MCP1525/1541

3.0 PIN FUNCTIONS

Name	Function
Output Pin (V_{OUT}):	Reference Output
Input Pin (V_{IN}):	Positive Input Voltage
Ground Pin (V_{SS}):	Negative Supply or Ground Connection

4.0 DETAILED DESCRIPTION

4.0.1 OUTPUT VOLTAGE

Output Voltage is the reference voltage that is available on the output pin (V_{OUT}).

4.0.2 OPERATING (INPUT) VOLTAGE

Input voltage is the range of voltage that can be applied to the V_{IN} pin and still have the device produce the designated output voltage on the V_{OUT} pin.

4.0.3 OUTPUT VOLTAGE DRIFT (TCV_{OUT})

The output temperature coefficient or voltage drift is a measure of how much the output voltage (V_{OUT}) will vary from its initial value with changes in temperature. The value specified in the electrical specifications is measured and equal to:

$$TCV_{OUT} = \frac{\left(\frac{\Delta V_{OUT}}{V_{NOM}}\right)}{\Delta T} \text{ \{in ppm/}^\circ\text{C}\}$$

Where:

$$V_{NOM} = 2.5V \text{ for the MCP1525 and } 4.096V \text{ for the MCP1541.}$$

4.0.4 DROPOUT VOLTAGE

The dropout voltage of these devices is measured by reducing V_{IN} in voltage to the point where the output drops by 1%. Under these conditions the dropout voltage is equal to:

$$V_{DROP} = V_{IN} - V_{OUT}$$

The dropout voltage is affected by temperature and load current.

In Figure 2-18, the dropout voltage is shown over a negative and positive range of output current. For currents above zero milliamperes, the dropout voltage is positive. In this case, the voltage reference is primarily powered by V_{IN} . With output currents below zero milliamperes, the dropout voltage is negative. As the output current becomes more negative the input current, I_{IN} , reduces. Under this condition, the output current begins to provide the needed power to the voltage reference.

4.0.5 LINE REGULATION

This is a measure of the change in output voltage (V_{OUT}) as a function of a change in the input voltage (V_{IN}). This is expressed as $\Delta V_{OUT}/\Delta V_{IN}$ and is measured in either $\mu V/V$ or ppm. For example, a $1 \mu V$ change in V_{OUT} caused by a 500 mV change in V_{IN} would net a $\Delta V_{OUT}/\Delta V_{IN}$ of $2 \mu V/V$ or 2 ppm.

4.0.6 LOAD REGULATION ($\Delta V_{OUT}/\Delta I_{OUT}$)

Load regulation is a measure of the change in the output voltage, V_{OUT} , as a function of the change in output current (I_{OUT}). Load regulation is usually measured in mV/mA.

4.0.7 INPUT CURRENT

The input (operating) current is the current that sinks from V_{IN} to V_{SS} without a load current on the output pin. This current is affected by temperature and the output current.

4.0.8 INPUT VOLTAGE REJECTION RATIO

The input voltage rejection ratio is a measure of the change in output voltage versus the change in input voltage over frequency as shown in Figure 2-7. The calculation used for this specification is:

$$\text{Input Voltage Rejection Ratio (dB)} = 20 \log \left(\frac{\delta V_{IN}}{\delta V_{OUT}} \right)$$

4.0.9 LONG TERM OUTPUT STABILITY

The long term output stability is measured by exposing the devices to a temperature of 125°C while configured in the circuit shown in Figure 4-1. In this test, all electrical specifications of the devices are measured periodically at 25°C as shown in Figure 2-9.

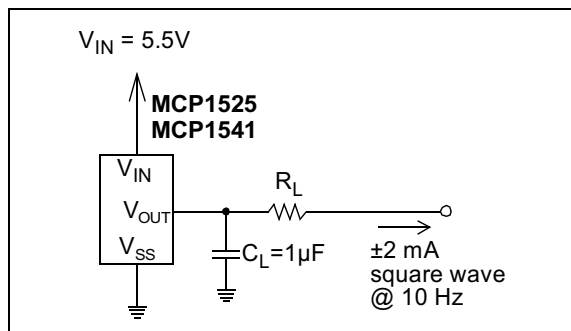

FIGURE 4-1: Dynamic Life Test Configuration

4.0.10 OUTPUT VOLTAGE HYSTERESIS

The output voltage hysteresis is a measure of the output voltage error after the powered devices are cycled over the entire operating temperature range. The amount of hysteresis can be quantified by measuring the change in the 25°C output voltage after temperature excursions from +25°C to +85°C to +25°C and also from +25°C to -40°C to +25°C.

5.0 APPLICATIONS INFORMATION

5.1 Bypass Capacitor

The MCP1525 and MCP1541 voltage references do not require an input capacitor across V_{IN} to V_{SS} , but for added stability and input voltage transient noise reduction, a 0.1 μF ceramic capacitor is recommended, as shown in Figure 5-1. This capacitor should be as close to the device as possible (within one inch).

5.2 Load Capacitor

The output capacitor from V_{OUT} to V_{SS} acts as a frequency compensation for the references and cannot be omitted. Values between 1.0 μF to 10 μF adequately compensate these devices. A higher value output capacitor will slightly improve the noise at the output of the reference as well as provide additional charge for fast transients from the load.

5.3 Printed Circuit Board Layout Considerations

Mechanical stress due to PC board mounting can cause the output voltage to shift from its initial value. Devices in the SOT23-3 package are generally more prone to assembly stress than devices in the TO-92 package. To reduce stress related output voltage shifts, mount the reference on low stress areas on the PC board, such as the board edges or corners.

5.4 Typical Application Circuits

5.4.1 BASIC CIRCUIT CONFIGURATION

The MCP1525 and MCP1541 voltage reference devices should be applied in all applications as shown in Figure 5-1.

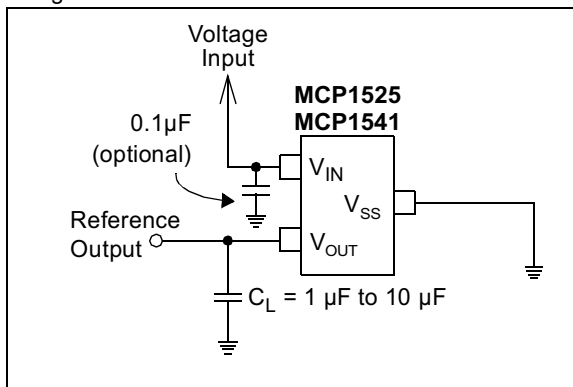

FIGURE 5-1: Basic circuit configuration for the MCP1525 and MCP1541.

As shown in Figure 5-1, the input voltage is connected to the device at the V_{IN} input with an optional 0.1 μF ceramic capacitor. This capacitor would be required if the input voltage has excess noise. A 0.1 μF would reject input voltage noise at approximately 1 MHz to 2 MHz. Noise below this frequency will be amply

rejected by the input voltage rejection of the voltage reference. Noise at frequencies above 2 MHz will be beyond the bandwidth of the voltage reference and consequently not transmitted from the input pin through the device to the output.

The load capacitance, C_L , is required in order to stabilize the voltage reference.

5.4.2 OUTPUT FILTERING

If the noise at the output of these voltage references is too high for the particular application, it can be easily filtered with an external R/C pair and amplifier.

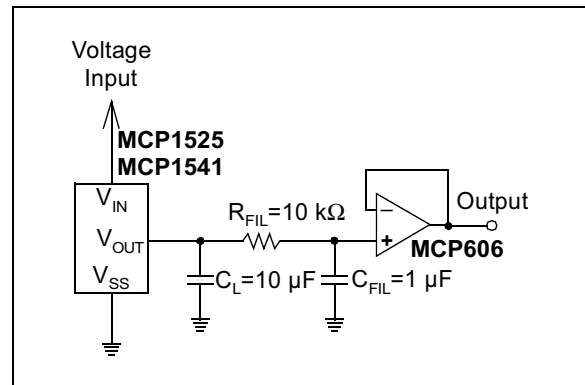

FIGURE 5-2: The output noise of these voltage references can be further reduced with a simple low pass filter.

The R/C pair is selected for a desired cut-off frequency which is equal to:

$$f_{CUTOFF} = \frac{1}{(2\pi R_{FIL} \cdot C_{FIL})}$$

The values that are shown in Figure 5-2 (10 k Ω and 1 μF) will create a first order low pass filter at the output of the amplifier. The corner frequency of this filter 15.9 Hz with an attenuation of 20 dB/decade. The MCP606 amplifier isolates the loading of this low pass filter from the remainder of the application circuit. This amplifier also provides additional drive and with a faster response time as compared to the voltage reference.

5.4.3 PRECISION ADJUSTABLE REFERENCE

A precision adjustable voltage reference can be configured with the circuit shown in Figure 5-3.

MCP1525/1541

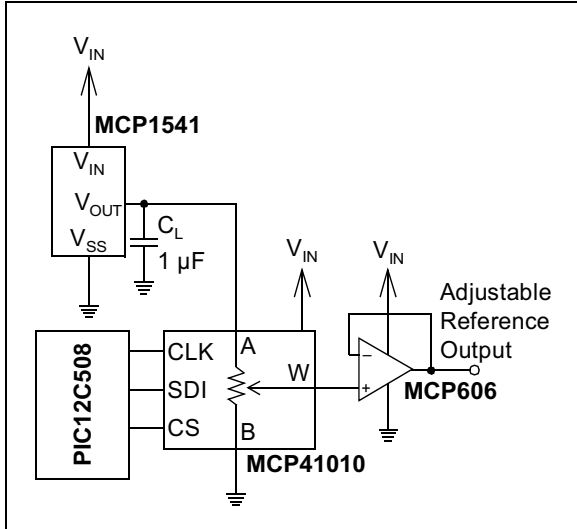

FIGURE 5-3: Adjustable Voltage Reference

In this circuit, the MCP1541 voltage reference is used to drive the resistor element of the MCP41010 digital potentiometer. The MCP41010 is a 256-tap potentiometer, 10 kΩ programmed using the SPI™ interface. The range of this adjustable reference is from ground to 4.096V in 16 mV increments.

5.4.4 NEGATIVE VOLTAGE REFERENCE

A negative precision voltage reference can be generated by using the MCP1525 or MCP1541 in the configuration shown in Figure 5-4.

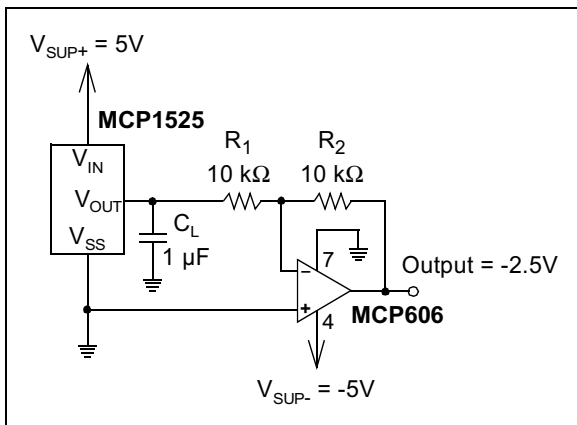

FIGURE 5-4: Negative Voltage Reference

In this circuit, the voltage divider configuration is implemented using the MCP606 and two equal resistors. The voltage at the output of the MCP1525 voltage reference drives R_1 which is connected to the inverting input of the MCP606 amplifier. Since the non-inverting input of the amplifier is biased to ground, the inverting input will also be approximately at ground potential. The second 10 kΩ resistor is placed around the feedback loop of the amplifier. Since the inverting input of the amplifier is high impedance, the current generated

SPI™ is a trademark of Motorola Inc.

through R_1 will also flow through R_2 . As a consequence, the output voltage of the amplifier is equal to -2.5V.

5.4.5 A-TO-D CONVERTER REFERENCE

The MCP1525 and MCP1541 were carefully designed to provide a voltage reference for Microchip's 10-bit and 12-bit family of A/D converters.

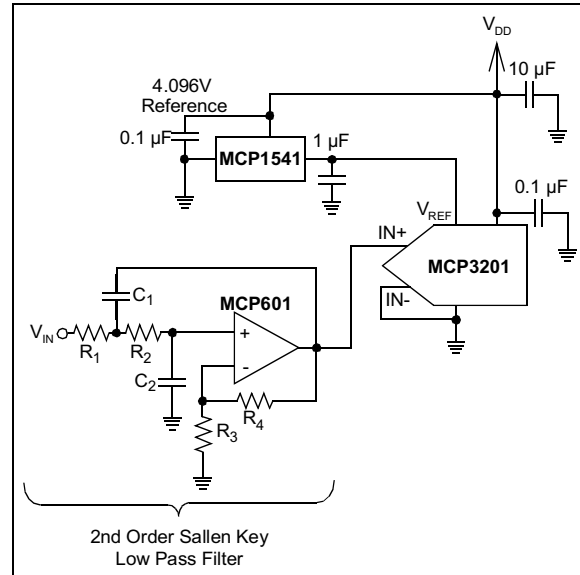

FIGURE 5-5: A/D Converter Reference Circuit.

The circuit shown in Figure 5-5 shows a MCP1541 configured to provide the reference to the MCP3201, a 12-bit A/D Converter. Use Microchip's Filter Lab™ software to design the Sallen Key filter. For additional information, refer to AN699, "Anti-Aliasing, Analog Filters for Data Acquisition Systems", DS00699.

6.0 PACKAGING INFORMATION

6.1 Package Marking Information

3-Lead TO-92

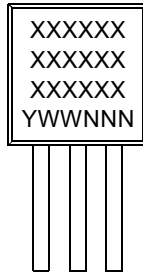

Example:

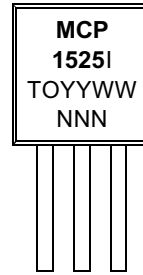

3-Lead SOT23-3

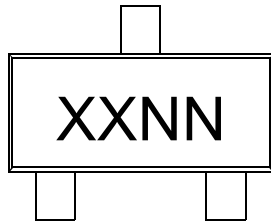

Example:

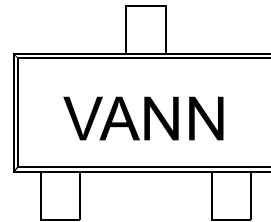

SOT23 PARTS LABELING:

The table below identifies the first 2 characters (XX) in the 4-character field (XXNN) for marking of the 3-Lead SOT23 package.

Mark	Part Number	Mark	Part Number
VA	MCP1525T-I/TT	VB	MCP1541T-I/TT

Legend:	XX...X	Customer specific information*
	YY	Year code (last 2 digits of calendar year)
	WW	Week code (week of January 1 is week '01')
	NNN	Alphanumeric traceability code
Note:	In the event the full Microchip part number cannot be marked on one line, it will be carried over to the next line thus limiting the number of available characters for customer specific information.	

- * Standard marking consists of Microchip part number, year code, week code, traceability code (facility code, mask rev#, and assembly code). For marking beyond this, certain price adders apply. Please check with your Microchip Sales Office.

MCP1525/1541

3-Lead Plastic Transistor Outline (TO) (TO-92)

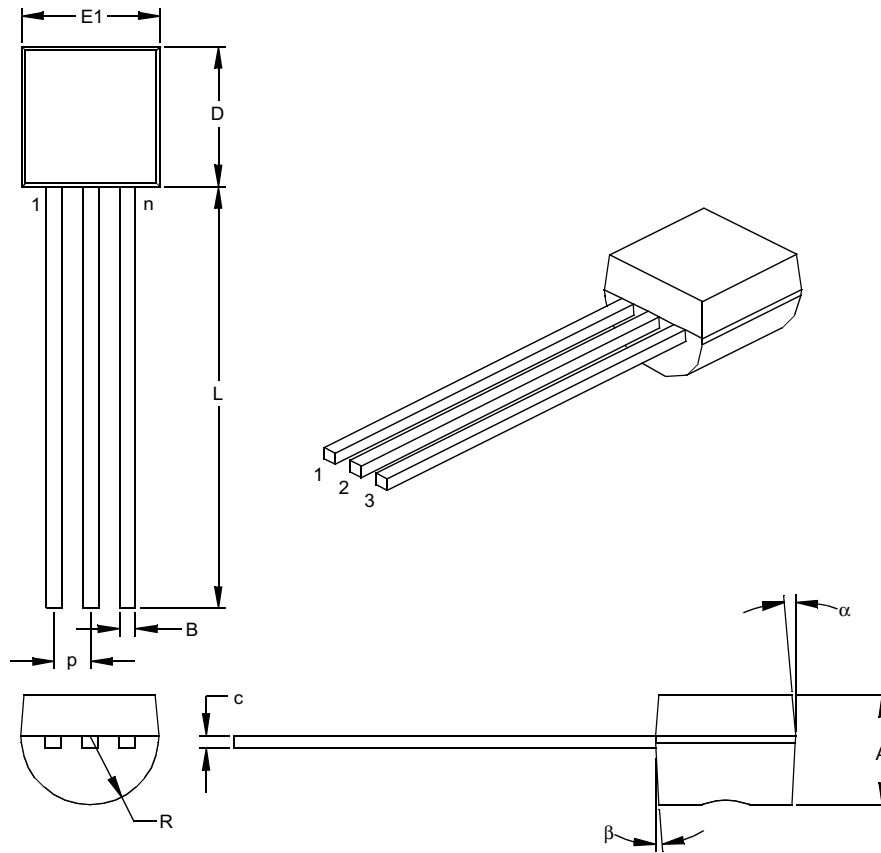

Dimension Limits	Units	INCHES*			MILLIMETERS		
		MIN	NOM	MAX	MIN	NOM	MAX
Number of Pins	n		3			3	
Pitch	p		.050			1.27	
Bottom to Package Flat	A	.130	.143	.155	3.30	3.62	3.94
Overall Width	E1	.175	.186	.195	4.45	4.71	4.95
Overall Length	D	.170	.183	.195	4.32	4.64	4.95
Molded Package Radius	R	.085	.090	.095	2.16	2.29	2.41
Tip to Seating Plane	L	.500	.555	.610	12.70	14.10	15.49
Lead Thickness	c	.014	.017	.020	0.36	0.43	0.51
Lead Width	B	.016	.019	.022	0.41	0.48	0.56
Mold Draft Angle Top	α	4	5	6	4	5	6
Mold Draft Angle Bottom	β	2	3	4	2	3	4

*Controlling Parameter

Notes:

Dimensions D and E1 do not include mold flash or protrusions. Mold flash or protrusions shall not exceed .010" (0.254mm) per side.

JEDEC Equivalent: TO-92

Drawing No. C04-101

3-Lead Plastic Small Outline Transistor (TT) (SOT23)

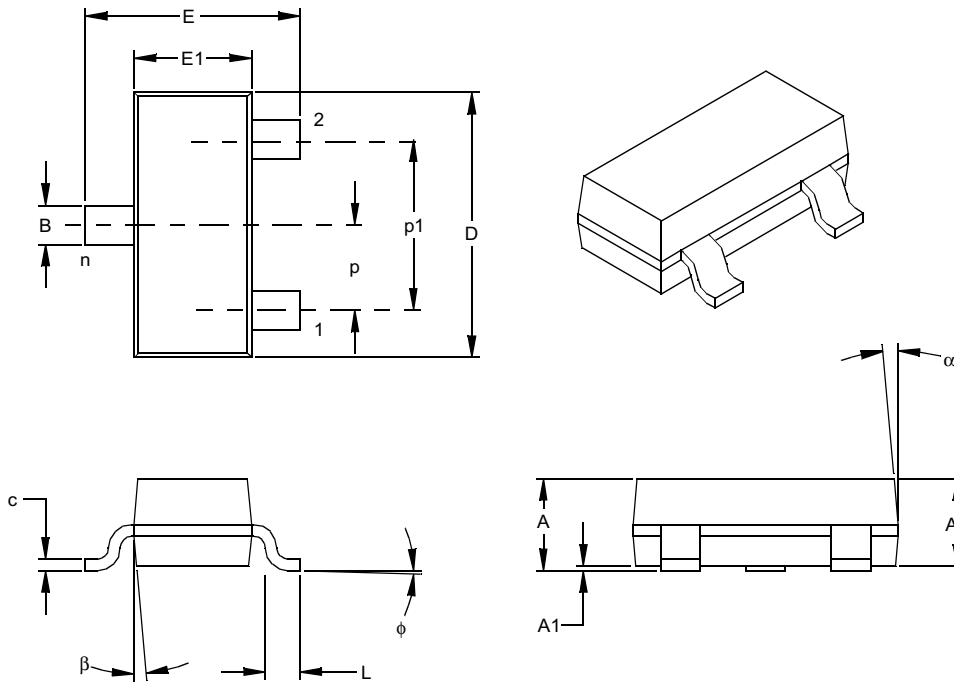

Units		INCHES*			MILLIMETERS		
Dimension	Limits	MIN	NOM	MAX	MIN	NOM	MAX
Number of Pins	n		3			3	
Pitch	p		.038			0.96	
Outside lead pitch (basic)	p1		.076			1.92	
Overall Height	A	.035	.040	.044	0.89	1.01	1.12
Molded Package Thickness	A2	.035	.037	.040	0.88	0.95	1.02
Standoff §	A1	.000	.002	.004	0.01	0.06	0.10
Overall Width	E	.083	.093	.104	2.10	2.37	2.64
Molded Package Width	E1	.047	.051	.055	1.20	1.30	1.40
Overall Length	D	.110	.115	.120	2.80	2.92	3.04
Foot Length	L	.014	.018	.022	0.35	0.45	0.55
Foot Angle	φ	0	5	10	0	5	10
Lead Thickness	c	.004	.006	.007	0.09	0.14	0.18
Lead Width	B	.015	.017	.020	0.37	0.44	0.51
Mold Draft Angle Top	α	0	5	10	0	5	10
Mold Draft Angle Bottom	β	0	5	10	0	5	10

* Controlling Parameter
 § Significant Characteristic

Notes:

Dimensions D and E1 do not include mold flash or protrusions. Mold flash or protrusions shall not exceed .010" (0.254mm) per side.

JEDEC Equivalent: TO-236

Drawing No. C04-104

MCP1525/1541

NOTES:

ON-LINE SUPPORT

Microchip provides on-line support on the Microchip World Wide Web (WWW) site.

The web site is used by Microchip as a means to make files and information easily available to customers. To view the site, the user must have access to the Internet and a web browser, such as Netscape or Microsoft Explorer. Files are also available for FTP download from our FTP site.

Connecting to the Microchip Internet Web Site

The Microchip web site is available by using your favorite Internet browser to attach to:

www.microchip.com

The file transfer site is available by using an FTP service to connect to:

<ftp://ftp.microchip.com>

The web site and file transfer site provide a variety of services. Users may download files for the latest Development Tools, Data Sheets, Application Notes, User's Guides, Articles and Sample Programs. A variety of Microchip specific business information is also available, including listings of Microchip sales offices, distributors and factory representatives. Other data available for consideration is:

- Latest Microchip Press Releases
- Technical Support Section with Frequently Asked Questions
- Design Tips
- Device Errata
- Job Postings
- Microchip Consultant Program Member Listing
- Links to other useful web sites related to Microchip Products
- Conferences for products, Development Systems, technical information and more
- Listing of seminars and events

Systems Information and Upgrade Hot Line

The Systems Information and Upgrade Line provides system users a listing of the latest versions of all of Microchip's development systems software products. Plus, this line provides information on how customers can receive any currently available upgrade kits. The Hot Line Numbers are:

1-800-755-2345 for U.S. and most of Canada, and
1-480-792-7302 for the rest of the world.

013001

MCP1525/1541

READER RESPONSE

It is our intention to provide you with the best documentation possible to ensure successful use of your Microchip product. If you wish to provide your comments on organization, clarity, subject matter, and ways in which our documentation can better serve you, please FAX your comments to the Technical Publications Manager at (480) 792-4150.

Please list the following information, and use this outline to provide us with your comments about this Data Sheet.

To: Technical Publications Manager Total Pages Sent
RE: Reader Response
From: Name _____
Company _____
Address _____
City / State / ZIP / Country _____
Telephone: (_____) _____ - _____ FAX: (_____) _____ - _____

Application (optional):

Would you like a reply? ___Y ___N

Device: **MCP1525/1541** Literature Number: **DS21653A**

Questions:

1. What are the best features of this document?

2. How does this document meet your hardware and software development needs?

3. Do you find the organization of this data sheet easy to follow? If not, why?

4. What additions to the data sheet do you think would enhance the structure and subject?

5. What deletions from the data sheet could be made without affecting the overall usefulness?

6. Is there any incorrect or misleading information (what and where)?

7. How would you improve this document?

8. How would you improve our software, systems, and silicon products?

PRODUCT IDENTIFICATION SYSTEM

To order or obtain information, e.g., on pricing or delivery, refer to the factory or the listed sales office.

<u>PART NO.</u>	<u>X</u>	<u>/XX</u>
Device	Temperature Range	Package
Device	MCP1525: = 2.5V Voltage Reference MCP1541: = 4.096 Voltage Reference	
Temperature Range	I = -40°C to +85°C	
Package	TO = TO-92, Plastic Transistor Outline, 3-Lead TT = SOT23, Plastic Small Outline Transistor, 3-Lead	

Examples:

- MCP1525T-I/TT: Tape and Reel, Industrial Temperature, SOT23 package.
- MCP1525-I/TO: Industrial Temperature, TO-92 package.
- MCP1541T-I/TT: Tape and Reel, Industrial Temperature, SOT23 package.
- MCP1541-I/TO: Industrial Temperature, TO-92 package.

Sales and Support

Data Sheets

Products supported by a preliminary Data Sheet may have an errata sheet describing minor operational differences and recommended workarounds. To determine if an errata sheet exists for a particular device, please contact one of the following:

- Your local Microchip sales office
- The Microchip Corporate Literature Center U.S. FAX: (480) 792-7277
- The Microchip Worldwide Site (www.microchip.com)

Please specify which device, revision of silicon and Data Sheet (include Literature #) you are using.

New Customer Notification System

Register on our web site (www.microchip.com/cn) to receive the most current information on our products.

MCP1525/1541

NOTES:

Information contained in this publication regarding device applications and the like is intended through suggestion only and may be superseded by updates. It is your responsibility to ensure that your application meets with your specifications. No representation or warranty is given and no liability is assumed by Microchip Technology Incorporated with respect to the accuracy or use of such information, or infringement of patents or other intellectual property rights arising from such use or otherwise. Use of Microchip's products as critical components in life support systems is not authorized except with express written approval by Microchip. No licenses are conveyed, implicitly or otherwise, under any intellectual property rights.

Trademarks

The Microchip name and logo, the Microchip logo, PIC, PICmicro, PICMASTER, PICSTART, PRO MATE, KEELoQ, SEEVAL, MPLAB and The Embedded Control Solutions Company are registered trademarks of Microchip Technology Incorporated in the U.S.A. and other countries.

Total Endurance, ICSP, In-Circuit Serial Programming, Filter-Lab, MXDEV, microID, FlexROM, fuzzyLAB, MPASM, MPLINK, MPLIB, PICC, PICDEM, PICDEM.net, ICEPIC, Migratable Memory, FanSense, ECONOMONITOR, Select Mode and microPort are trademarks of Microchip Technology Incorporated in the U.S.A.

Serialized Quick Term Programming (SQTP) is a service mark of Microchip Technology Incorporated in the U.S.A.

All other trademarks mentioned herein are property of their respective companies.

© 2001, Microchip Technology Incorporated, Printed in the U.S.A., All Rights Reserved.

 Printed on recycled paper.

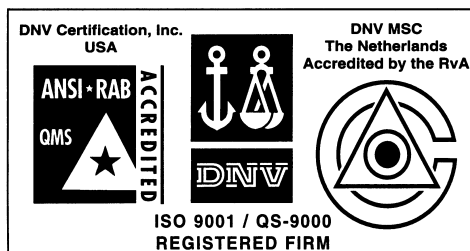

Microchip received QS-9000 quality system certification for its worldwide headquarters, design and wafer fabrication facilities in Chandler and Tempe, Arizona in July 1999. The Company's quality system processes and procedures are QS-9000 compliant for its PICmicro® 8-bit MCUs, KEELoQ® code hopping devices, Serial EEPROMs and microperipheral products. In addition, Microchip's quality system for the design and manufacture of development systems is ISO 9001 certified.



MICROCHIP

WORLDWIDE SALES AND SERVICE

AMERICAS

Corporate Office

2355 West Chandler Blvd.
Chandler, AZ 85224-6199
Tel: 480-792-7200 Fax: 480-792-7277
Technical Support: 480-792-7627
Web Address: <http://www.microchip.com>

Rocky Mountain

2355 West Chandler Blvd.
Chandler, AZ 85224-6199
Tel: 480-792-7966 Fax: 480-792-7456

Atlanta

500 Sugar Mill Road, Suite 200B
Atlanta, GA 30350
Tel: 770-640-0034 Fax: 770-640-0307

Austin - Analog

8303 MoPac Expressway North
Suite A-201
Austin, TX 78759
Tel: 512-345-2030 Fax: 512-345-6085

Boston

2 Lan Drive, Suite 120
Westford, MA 01886
Tel: 978-692-3848 Fax: 978-692-3821

Boston - Analog

Unit A-8-1 Millbrook Tarry Condominium
97 Lowell Road
Concord, MA 01742
Tel: 978-371-6400 Fax: 978-371-0050

Chicago

333 Pierce Road, Suite 180
Itasca, IL 60143
Tel: 630-285-0071 Fax: 630-285-0075

Dallas

4570 Westgrove Drive, Suite 160
Addison, TX 75001
Tel: 972-818-7423 Fax: 972-818-2924

Dayton

Two Prestige Place, Suite 130
Miamisburg, OH 45342
Tel: 937-291-1654 Fax: 937-291-9175

Detroit

Tri-Atria Office Building
32255 Northwestern Highway, Suite 190
Farmington Hills, MI 48334
Tel: 248-538-2250 Fax: 248-538-2260

Los Angeles

18201 Von Karman, Suite 1090
Irvine, CA 92612
Tel: 949-263-1888 Fax: 949-263-1338

New York

150 Motor Parkway, Suite 202
Hauppauge, NY 11788
Tel: 631-273-5305 Fax: 631-273-5335

San Jose

Microchip Technology Inc.
2107 North First Street, Suite 590
San Jose, CA 95131
Tel: 408-436-7950 Fax: 408-436-7955

Toronto

6285 Northam Drive, Suite 108
Mississauga, Ontario L4V 1X5, Canada
Tel: 905-673-0699 Fax: 905-673-6509

ASIA/PACIFIC

Australia

Microchip Technology Australia Pty Ltd
Suite 22, 41 Rawson Street
Epping 2121, NSW
Australia
Tel: 61-2-9868-6733 Fax: 61-2-9868-6755

China - Beijing

Microchip Technology Consulting (Shanghai)
Co., Ltd., Beijing Liaison Office
Unit 915
New China Hong Kong Manhattan Bldg.
No. 6 Chaoyangmen Beidajie
Beijing, 100027, No. China
Tel: 86-10-85282100 Fax: 86-10-85282104

China - Chengdu

Microchip Technology Consulting (Shanghai)
Co., Ltd., Chengdu Liaison Office
Rm. 2401, Ming Xing Financial Tower
No. 88 TIDU Street
Chengdu 610016, China
Tel: 86-28-6766200 Fax: 86-28-6766599

China - Fuzhou

Microchip Technology Consulting (Shanghai)
Co., Ltd., Fuzhou Liaison Office
Rm. 531, North Building
Fujian Foreign Trade Center Hotel
73 Wusi Road
Fuzhou 350001, China
Tel: 86-591-7557563 Fax: 86-591-7557572

China - Shanghai

Microchip Technology Consulting (Shanghai)
Co., Ltd.
Room 701, Bldg. B
Far East International Plaza
No. 317 Xian Xia Road
Shanghai, 200051
Tel: 86-21-6275-5700 Fax: 86-21-6275-5060

China - Shenzhen

Microchip Technology Consulting (Shanghai)
Co., Ltd., Shenzhen Liaison Office
Rm. 1315, 13/F, Shenzhen Kerry Centre,
Renminnan Lu
Shenzhen 518001, China
Tel: 86-755-2350361 Fax: 86-755-2366086

Hong Kong

Microchip Technology Hongkong Ltd.
Unit 901, Tower 2, Metroplaza
223 Hing Fong Road
Kwai Fong, N.T., Hong Kong
Tel: 852-2401-1200 Fax: 852-2401-3431

India

Microchip Technology Inc.
India Liaison Office
Divyasree Chambers
1 Floor, Wing A (A3/A4)
No. 11, O'Shaughnessy Road
Bangalore, 560 025, India
Tel: 91-80-2290061 Fax: 91-80-2290062

Japan

Microchip Technology Japan K.K.
Benex S-1 6F
3-18-20, Shinyokohama
Kohoku-Ku, Yokohama-shi
Kanagawa, 222-0033, Japan
Tel: 81-45-471-6166 Fax: 81-45-471-6122

Korea

Microchip Technology Korea
168-1, Youngbo Bldg. 3 Floor
Samsung-Dong, Kangnam-Ku
Seoul, Korea 135-882
Tel: 82-2-554-7200 Fax: 82-2-558-5934

Singapore

Microchip Technology Singapore Pte Ltd.
200 Middle Road
#07-02 Prime Centre
Singapore, 188980
Tel: 65-334-8870 Fax: 65-334-8850

Taiwan

Microchip Technology Taiwan
11F-3, No. 207
Tung Hua North Road
Taipei, 105, Taiwan
Tel: 886-2-2717-7175 Fax: 886-2-2545-0139

EUROPE

Denmark

Microchip Technology Denmark ApS
Regus Business Centre
Lautrup høj 1-3
Ballerup DK-2750 Denmark
Tel: 45 4420 9895 Fax: 45 4420 9910

France

Arizona Microchip Technology SARL
Parc d'Activite du Moulin de Massy
43 Rue du Saule Trapu
Batiment A - 1er Etage
91300 Massy, France
Tel: 33-1-69-53-63-20 Fax: 33-1-69-30-90-79

Germany

Arizona Microchip Technology GmbH
Gustav-Heinemann Ring 125
D-81739 Munich, Germany
Tel: 49-89-627-144 0 Fax: 49-89-627-144-44

Germany - Analog

Lochamer Strasse 13
D-82152 Martinsried, Germany
Tel: 49-89-895650-0 Fax: 49-89-895650-22

Italy

Arizona Microchip Technology SRL
Centro Direzionale Colleoni
Palazzo Taurus 1 V. Le Colleoni 1
20041 Agrate Brianza
Milan, Italy
Tel: 39-039-65791-1 Fax: 39-039-6899883

United Kingdom

Arizona Microchip Technology Ltd.
505 Eskdale Road
Winnersh Triangle
Wokingham
Berkshire, England RG41 5TU
Tel: 44 118 921 5869 Fax: 44-118 921-5820

06/01/01