

Features and Benefits

- ❑ Operating Voltage from 1.6 to 3.6V
- ❑ Latching Output Behavior
- ❑ Micropower Consumption
48uA@3V ; 36uA@1.8V
- ❑ Advanced Power Manageability through dedicated “Enable” pin
- ❑ Ultra High Sensitivity Hall Sensor
- ❑ Push-Pull Output
- ❑ Miniature & Ultra Thin CSP package
(2mm x 1.5mm ; 0.4mm thickness)
- ❑ “Green” and “Pb-Free” Compliant Package

Application Examples

- ❑ Battery-operated / Handheld Appliances
- ❑ Rotary or Linear Contact-Less Encoders
- ❑ Scroll/Jog Wheel, Trackball (Mobile Phones, Portable Media Players, Notebooks, Computer Mice, Camcorders, Cameras,...)
- ❑ Home/Industrial Metering Equipment (Wafer Flow Meter)

Ordering Information

Part No.	Temperature Code	Package Code
MLX92213	E (-40°C to 85°C)	LD (UTQFN-6L)

1 Functional Diagram

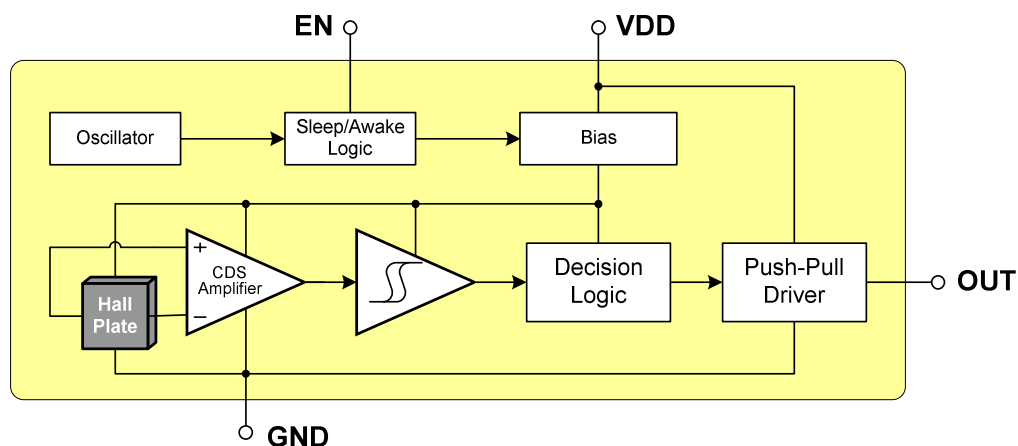

2 General Description

The MLX92213 Micropower Low-Voltage Latch Hall effect sensor IC is fabricated in mixed signal CMOS technology. It incorporates advanced Correlated Double Sampling (CDS) techniques to provide accurate and stable magnetic switching points.

In order to save power, the internal Timing Logic alternates Awake and Sleep modes, thus significantly reducing the power consumption. The magnetic flux density is periodically evaluated against predefined thresholds. If the flux density is above/below the B_{OP}/B_{RP} thresholds, then the Output changes its state accordingly. During the Sleep mode the Output is latched in its previous

state. The design has been optimized for applications requiring extended operating lifetime in battery-powered systems. The EN pin adds flexibility by enabling external control of the Micropower Period and Duty Cycle.

The Push-pull Output of the MLX92213 will be latched in Low state in the presence of a sufficiently strong South magnetic field ($B > B_{OP}$) facing the marked side of the package. The Output will be latched in High state in the presence of a sufficiently strong North magnetic field ($B < B_{RP}$).

Table of Contents

1 Functional Diagram	1
2 General Description	1
3 Glossary of Terms	3
4 Absolute Maximum Ratings	3
5 Pinout.....	3
6 Output Behavior vs. Magnetic Pole.....	3
7 General Electrical Specifications	4
8 Magnetic Specifications	5
9 Application Section	5
9.1 Application Schematics.....	5
9.2 Recommendation / Comments	5
10 Principle of Operation.....	6
11 Performance Graphs	7
11.1 Magnetic Threshold vs. Temperature.....	7
11.2 Magnetic Threshold vs. Supply Voltage	7
11.3 Average Supply Current vs. Temperature	7
11.4 Average Supply Current vs. Supply Voltage	7
11.5 Supply Current vs. Temperature.....	7
11.6 Supply Current vs. Supply Voltage	7
12 Standard information regarding manufacturability of Melexis products with different soldering processes.....	8
13 ESD Precautions	8
14 LD Package (UTQFN-6L).....	9
15 Disclaimer.....	10

3 Glossary of Terms

Gauss, milliTesla (mT), Units of magnetic flux density :
10 Gauss = 1mT

4 Absolute Maximum Ratings

Parameter	Symbol	Value	Units
Supply Voltage	V_{DD}	5	V
Supply Current	I_{DD}	± 10	mA
EN Input Voltage	V_{IN}	5	V
EN Input Current	I_{IN}	± 10	mA
Output Voltage	V_{OUT}	5	V
Output Current	I_{OUT}	± 10	mA
Operating Temperature Range	T_A	-40 to 85	$^{\circ}C$
Storage Temperature Range	T_S	-50 to 150	$^{\circ}C$

Table 1: Absolute maximum ratings

Exceeding the absolute maximum ratings may cause permanent damage. Exposure to absolute-maximum-rated conditions for extended periods may affect device reliability.

5 Pinout

Pin Name	Function	Pin No
VDD	Power Supply	3
GND	Ground	4, E-pad ⁽²⁾
OUT	Push-Pull Output	1
EN	Enable ⁽¹⁾	6
NC	Not Connected	2, 5

Table 2: Pin definitions and descriptions

Note 1: EN has to be connected to V_{DD} when External Micropower Control is not used

Note 2: Exposed Pad on LD package is connected to Ground

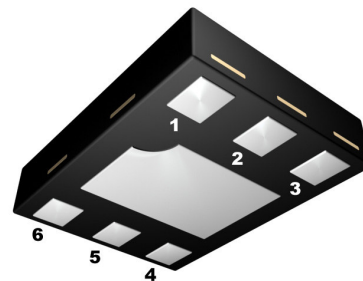

LD Package

6 Output Behavior vs. Magnetic Pole

DC Operating Parameters $T_A = -40^{\circ}C$ to $85^{\circ}C$, $V_{DD} = 1.6V$ to $3.6V$

Parameter	Test Conditions	OUT
South pole	$B > B_{OP}$	Low
North pole	$B < B_{RP}$	High

Table 3: Output behavior versus magnetic pole ⁽³⁾

Note 3: The magnetic pole is applied facing the package top

7 General Electrical Specifications

Operating Parameters: $T_A = -40$ to 85°C , $V_{DD} = 1.6\text{V}$ to 3.6V , unless otherwise specified

Parameter	Symbol	Test Conditions	Min	Typ	Max	Units
Supply Voltage	V_{DD}	Operating	1.6	-	3.6	V
Average Supply Current	I_{DDav}	$EN = V_{DD}$, $V_{DD}=3\text{V}$	-	48	86	μA
		$EN = V_{DD}$, $V_{DD}=1.8\text{V}$	-	36	70	μA
Awake Supply Current	I_{DDaw}	$EN = V_{DD}$, $I_{OUT} = 0\text{mA}$	-	-	4	mA
Sleep Supply Current	I_{DDsl}	$EN = V_{DD}$, $I_{OUT} = 0\text{mA}$	-	-	4.5	μA
Standby Supply Current	I_{DDsb}	$EN = 0$	-	-	1	μA
Output Characteristics						
High Level Output Voltage	V_{OH}	$B < B_{RP}$, $I_{OUT} = -1\text{mA}$	$V_{DD}-0.4$	$V_{DD}-0.2$	-	V
Low Level Output Voltage	V_{OL}	$B > B_{OP}$, $I_{OUT} = 1\text{mA}$	-	0.2	0.4	V
Power-On Output State ⁽⁴⁾	V_{PO}		High			-
Enable Pin Characteristics						
EN Input High Voltage	V_{IH}		$0.1 \cdot V_{DD} + 1$	-	-	V
EN Input Low Voltage	V_{IL}		-	-	$0.1 \cdot V_{DD} + 0.1$	V
EN Input Current	I_{IN}		-1	-	1	μA
EN Input Delay	t_{ID}		-	-	5	μs
EN Pulse Width	T_{E1}		5	-	-	μs
EN Period	T_{E2}		$T_{AW} + 0.1$	-	-	μs
Timing Characteristics						
Enable Transition Time ⁽⁵⁾	t_{ET}	Disabled \rightarrow Enabled	-	-	$t_{ID} + T_{AW}$	μs
Disable Transition Time ⁽⁶⁾	t_{DT}	Enabled \rightarrow Disabled	-	-	$t_{ID} + T_{AW}$	μs
Power-On Time ⁽⁷⁾	t_{ON}	$EN = V_{DD}$	-	31	80	μs
		$EN = V_{DD}$, $T_A=25^\circ\text{C}$, $V_{DD}=3\text{V}$	-	31	52	μs
Awake Time	T_{AW}	$EN = V_{DD}$	-	-	60	μs
		$EN = V_{DD}$, $T_A=25^\circ\text{C}$, $V_{DD}=3\text{V}$	-	27	40	μs
		$EN = V_{DD}$, $T_A=25^\circ\text{C}$, $V_{DD}=1.8\text{V}$	-	30	45	μs
Period	T_{PER}	$EN = V_{DD}$	0.70	1.30	1.90	ms
Response Time ⁽⁸⁾	t_{RES}	$EN = V_{DD}$	-	-	T_{PER}	ms
Magnetic Signal Frequency	f_B	$EN = V_{DD}$	$1 / [2 \cdot T_{PER}]$			Hz

Table 4: Electrical specifications

Note 4: Defined Output state after Power-On Time is High until the first BOP threshold is reached ($B > B_{OP}$).

Note 5: Enable transition time defined from EN command to the update of the Output driver state (ref. to Diagrams, p.4)

Note 6: Disable transition time defined from EN command to entering Standby (ref. to Diagrams, p.4)

Note 7: Power-On Time represents the time from reaching $V_{DD} = 1.6\text{V}$ to the update of the Output driver state

Note 8: Response Time is the time from the magnetic field change to the according update of the Output driver state, guaranteed by design

8 Magnetic Specifications

DC Operating Parameters: $V_{DD} = 1.6V$ to $3.6V$

Parameter	Symbol	Test Conditions	Min	Typ	Max	Units
Operating Point	B_{OP}	$T_A = 25^\circ C$	0.5	2	4	mT
Release Point	B_{RP}		-4	-2	-0.5	mT
Hysteresis	B_{HYST}		1.5	4	7	mT
Operating Point	B_{OP}	$T_A = -40$ to $85^\circ C$	0.1	2	5	mT
Release Point	B_{RP}		-5	-2	-0.1	mT
Hysteresis	B_{HYST}		1.5	4	7	mT

Table 5: Magnetic specifications

9 Application Section

9.1 Application Schematics

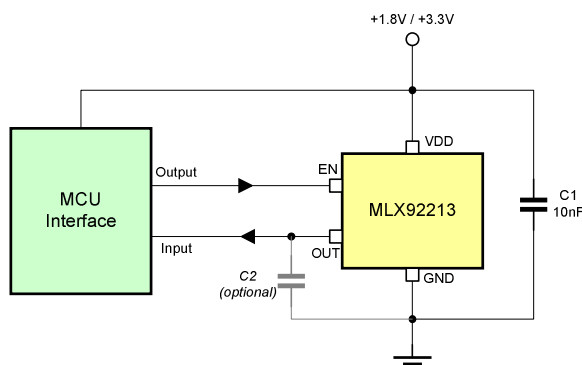

Fig. 1 – Enhanced Power Management
Typical 1.8V or 3.3V application with MCU interface reading the OUT signal and driving the EN signal

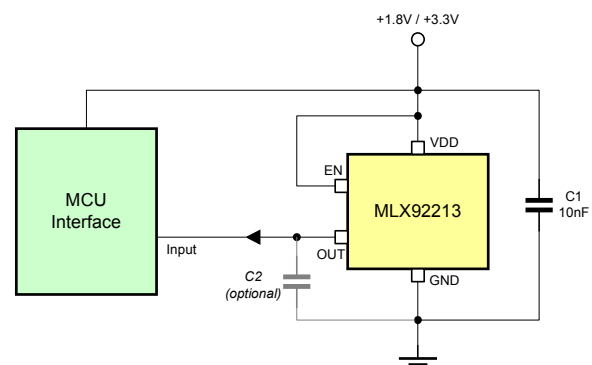

Fig. 2 – Standard Power Management
1.8V or 3.3V application with MCU interface reading the OUT signal with default “Micropower”

9.2 Recommendation / Comments

A bypass capacitor C1 of 10nF is recommended to ensure supply voltage stability in application. It should be placed between the VDD and GND pin, as close as possible to the MLX92213.

The MLX92213 provides a direct push-pull output, hence aiming to reduce external component count like output pull-up resistor or capacitor. The use of the output capacitor C2 connected in parallel to the output is optional. If connected between OUT and GND in such a push-pull configuration, the current sunk by the charge of the capacitor when the output switches from “0” to “1” leads to an small increase of the average current consumption of the whole module (IC + capacitor).

Using small capacitor value C2 (less than 50pF) would avoid having such small increase of the module average current consumption.

For enhanced power management, the EN (Enable) signal can be driven by an external MCU. It basically allows controlling the state IC and therefore its current consumption according the application requirements:

- Standby mode for minimal current consumption (EN = “0”)
- Default Micropower (EN = “1”)
- Faster or slower sampling rate through EN signal

For more details on the different mode, please refer to the *Principle of Operation* section.

For application where standard power management is enough (default “Micropower” mode, Standby unused), the EN pin should be tied to VDD

10 Principle of Operation

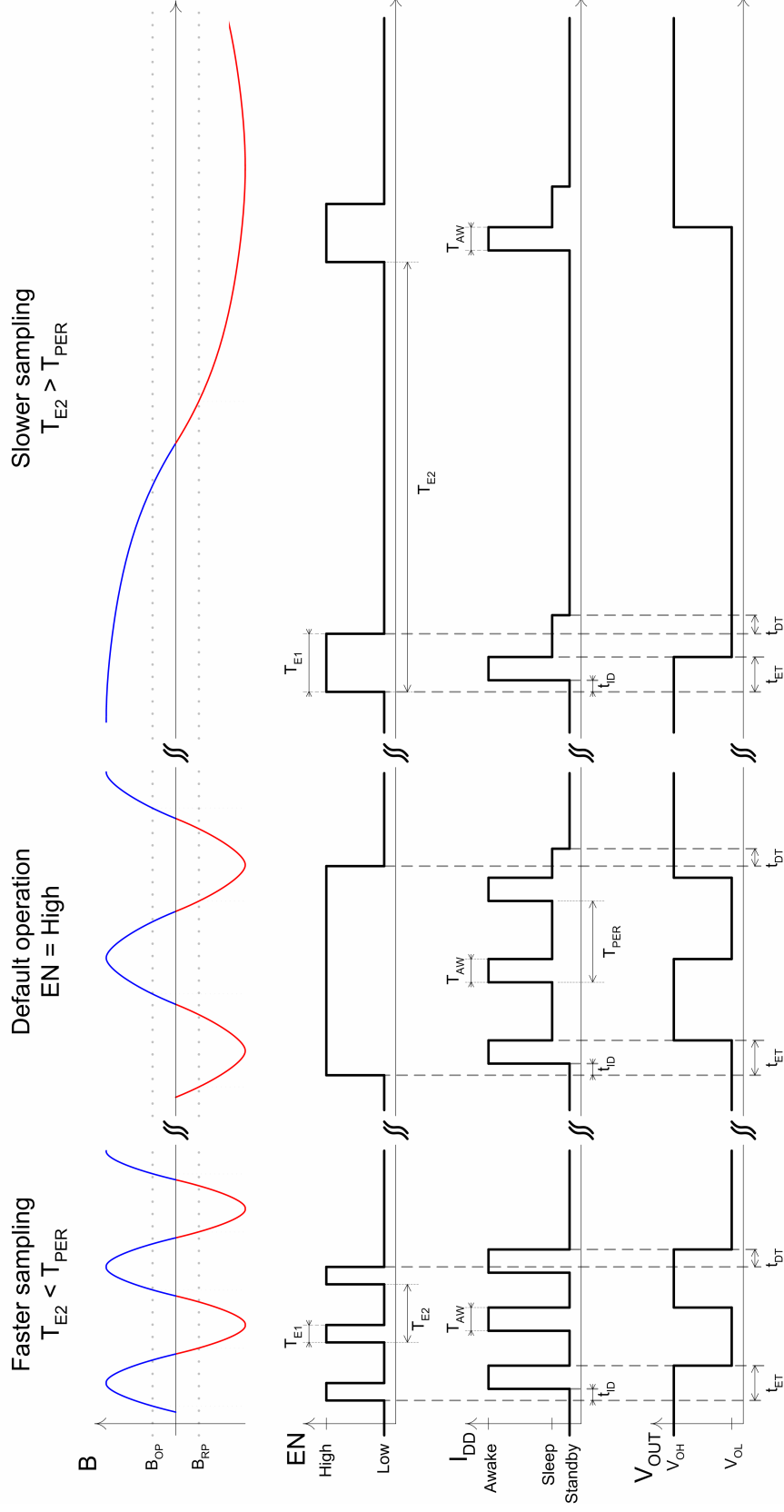

Note 9: The diagrams are not-to-scale, for exact values refer to General Electrical Specification

Note 10: The Output is assumed to have only a low capacitive load, which results in fast rise / fall times

11 Performance Graphs

11.1 Magnetic Threshold vs. Temperature

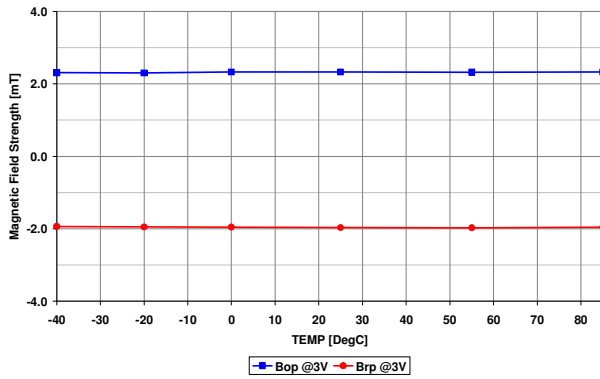

11.2 Magnetic Threshold vs. Supply Voltage

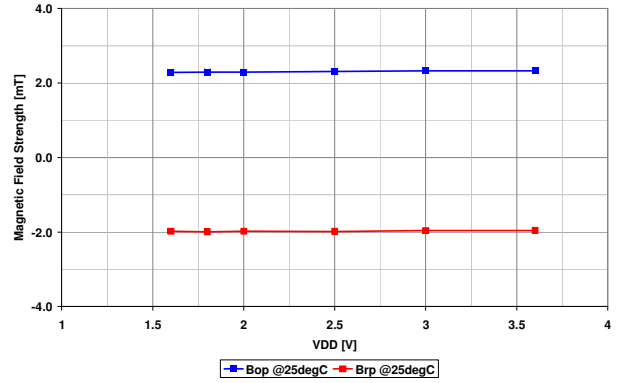

11.3 Average Supply Current vs. Temperature

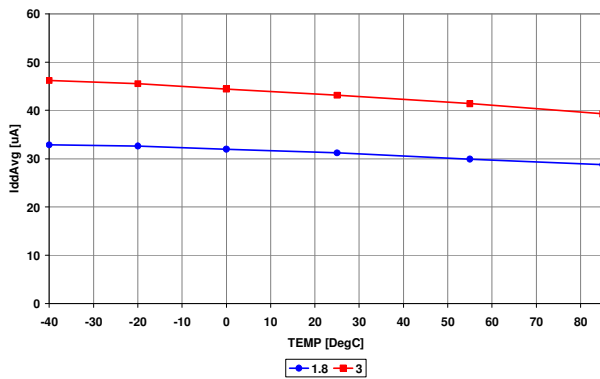

11.4 Average Supply Current vs. Supply Voltage

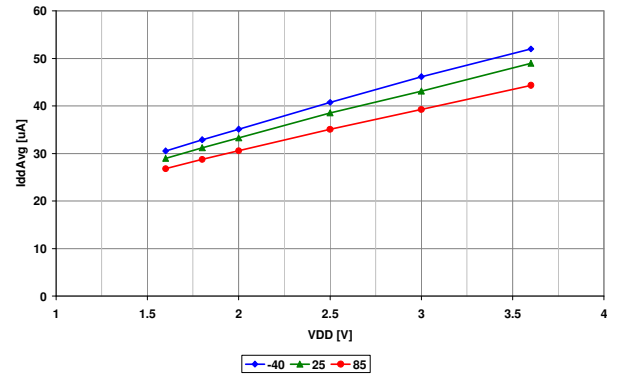

11.5 Supply Current vs. Temperature

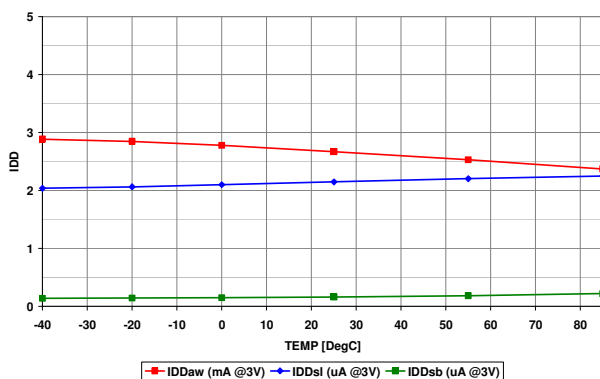

11.6 Supply Current vs. Supply Voltage

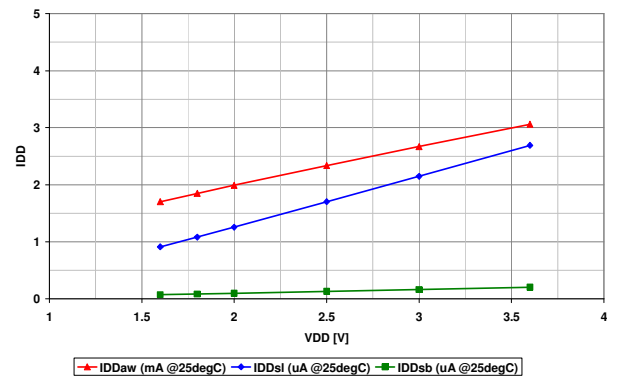

12 Standard information regarding manufacturability of Melexis products with different soldering processes

Our products are classified and qualified regarding soldering technology, solderability and moisture sensitivity level according to following test methods:

Reflow Soldering SMD's (Surface Mount Devices)

- IPC/JEDEC J-STD-020
Moisture/Reflow Sensitivity Classification for Nonhermetic Solid State Surface Mount Devices (classification reflow profiles according to table 5-2)
- EIA/JEDEC JESD22-A113
Preconditioning of Nonhermetic Surface Mount Devices Prior to Reliability Testing (reflow profiles according to table 2)

Wave Soldering SMD's (Surface Mount Devices) and THD's (Through Hole Devices)

- EN60749-20
Resistance of plastic- encapsulated SMD's to combined effect of moisture and soldering heat
- EIA/JEDEC JESD22-B106 and EN60749-15
Resistance to soldering temperature for through-hole mounted devices

Iron Soldering THD's (Through Hole Devices)

- EN60749-15
Resistance to soldering temperature for through-hole mounted devices

Solderability SMD's (Surface Mount Devices) and THD's (Through Hole Devices)

- EIA/JEDEC JESD22-B102 and EN60749-21
Solderability

For all soldering technologies deviating from above mentioned standard conditions (regarding peak temperature, temperature gradient, temperature profile etc) additional classification and qualification tests have to be agreed upon with Melexis.

The application of Wave Soldering for SMD's is allowed only after consulting Melexis regarding assurance of adhesive strength between device and board.

Melexis is contributing to global environmental conservation by promoting **lead free** solutions. For more information on qualifications of **RoHS** compliant products (RoHS = European directive on the Restriction Of the use of certain Hazardous Substances) please visit the quality page on our website:
<http://www.melexis.com/quality.aspx>

13 ESD Precautions

Electronic semiconductor products are sensitive to Electro Static Discharge (ESD). Always observe Electro Static Discharge control procedures whenever handling semiconductor products.

14 LD Package (UTQFN-6L)

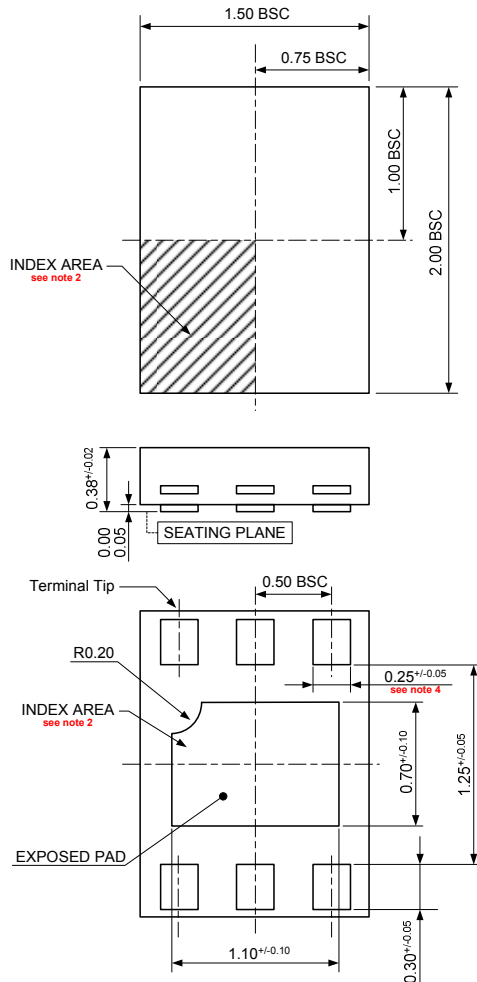

Notes:

1. All dimensions are in millimeters.
2. The terminal #1 identifier and terminal numbering convention shall conform JEDEC publication 95 SPP-002. Details of terminal #1 identifier are optional, but must be located within the zone indicated. The terminal #1 identifier may be marked feature.
3. Depopulation is possible in a symmetrical fashion.
4. Pad length applies to metallized terminal and is measured between 0.15mm and 0.30mm from the terminal tip. If the terminal has the optional radius on the other end of the terminal, the pad length should not be measured in that radius area.

Marking:

- 1st Line : .13
 " " (dot) - used to show the 1st pin
 13 - Name of the device (MLX92213)
- 2nd Line : YWW
 Y - Year (last digit)
 WW - Calendar Week

Hall plate location

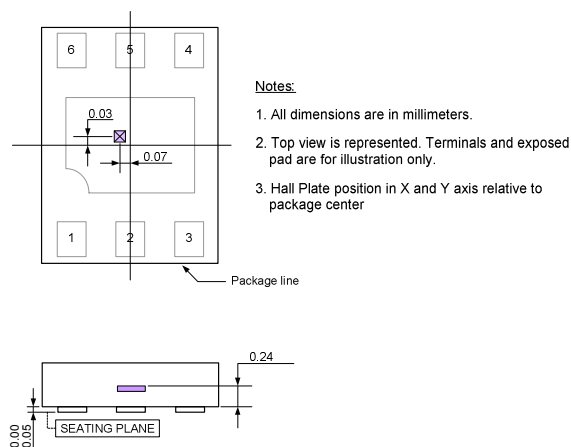

Land Pattern

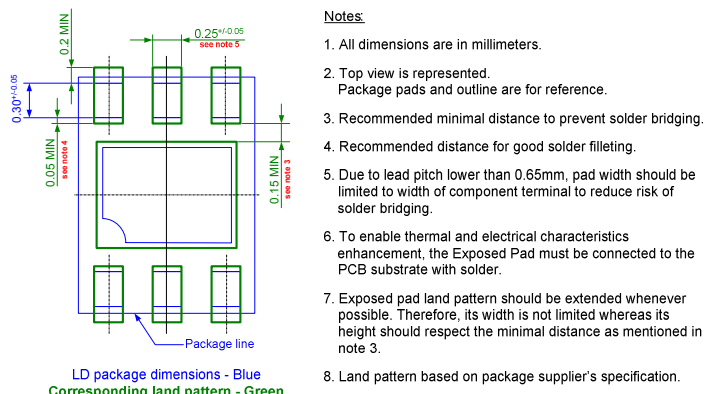

15 Disclaimer

Devices sold by Melexis are covered by the warranty and patent indemnification provisions appearing in its Term of Sale. Melexis makes no warranty, express, statutory, implied, or by description regarding the information set forth herein or regarding the freedom of the described devices from patent infringement. Melexis reserves the right to change specifications and prices at any time and without notice. Therefore, prior to designing this product into a system, it is necessary to check with Melexis for current information. This product is intended for use in normal commercial applications. Applications requiring extended temperature range, unusual environmental requirements, or high reliability applications, such as military, medical life-support or life-sustaining equipment are specifically not recommended without additional processing by Melexis for each application.

The information furnished by Melexis is believed to be correct and accurate. However, Melexis shall not be liable to recipient or any third party for any damages, including but not limited to personal injury, property damage, loss of profits, loss of use, interrupt of business or indirect, special incidental or consequential damages, of any kind, in connection with or arising out of the furnishing, performance or use of the technical data herein. No obligation or liability to recipient or any third party shall arise or flow out of Melexis' rendering of technical or other services.

© 2005 Melexis NV. All rights reserved.

For the latest version of this document, go to our website at
www.melexis.com

Or for additional information contact Melexis Direct:

Europe, Africa, Asia:
Phone: +32 1367 0495
E-mail: sales_europe@melexis.com

America:
Phone: +1 603 223 2362
E-mail: sales_usa@melexis.com

ISO/TS 16949 and ISO14001 Certified