

Molded DIP Reed Relays



DESCRIPTION

The DIP series is a very compact design having a low profile package and a high profile package. This series is compatible with all DIP relays.

CHARACTERISTICS

- Low profile package
- Standard pin configurations
- IC-pin compatible
- 4.25 kVDC breakdown voltage for pin out 13
- UL approval

FEATURES

- High resistance option available
- SMD version available
- Diode option available
- Mercury wetted switch option available

DIMENSIONS

All dimensions in mm [inches]

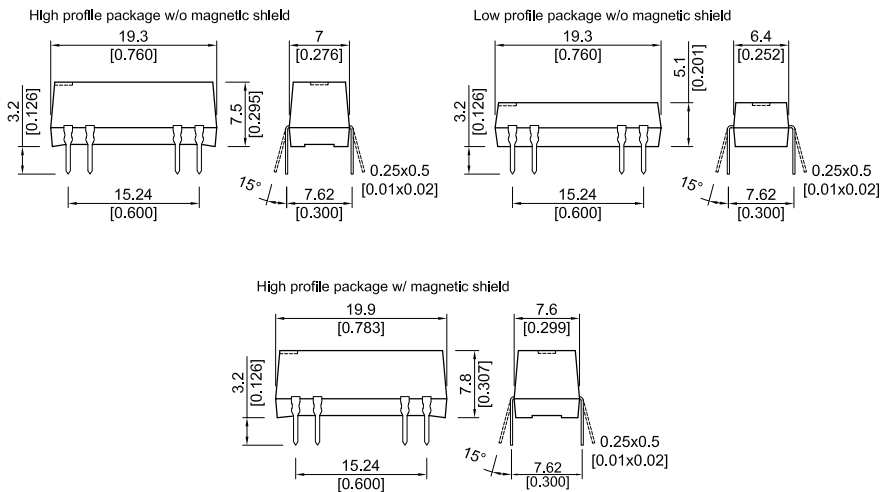

ORDER INFORMATION

Part Number Example

DIP12 - 1A72 - 13L

- 12 is the nominal voltage
- 1A is the contact form
- 72 is the switch model
- 13 is the pin out
- L is the option

Series	Nominal Voltage	Contact Form	Switch Model	Pin Out	Option () Version with magn. Shield
DIP	XX -	XX	XX -	XX	X
Options	05, 12, 15, 24	1A	72, 75	11, 13*	L(M), D(Q),E(R), F(S)
		1B		19	
		2A		21	
	05, 12	1C	90	51	

*Selects 4-25 (3.0 kVRMS) breakdown voltage contact to coil.

PIN OUT

View from top of component
2.54mm [0.10"] pitch grid

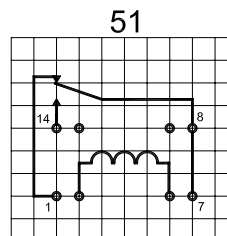
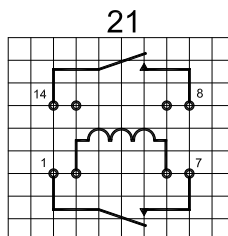
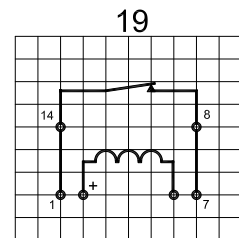
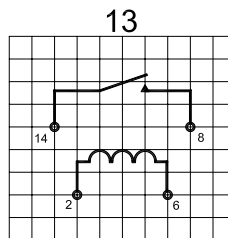
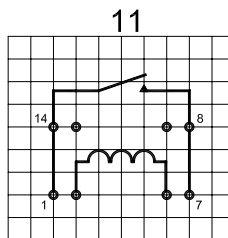

**Molded DIP
Reed Relays**

OPTIONS

() Versions with magnetic shield

View from top of component
2.54mm [0.10"] pitch grid

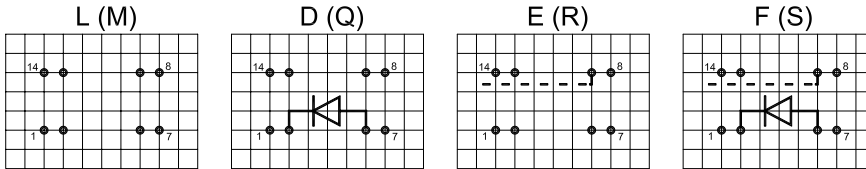

OPTIONS DEPENDENCE ON CASE SIZES

Contact Form	Package Size	Pin Out	Options							
			L	D	E	F	M	Q	R	S
1A	Low Profile	11	X		X					
		13	X							
1B	High Profile	11		X		X	X	X		X
		13		X			X	X		
1B	High Profile	19	X	X			X	X		
2A	High Profile	21	X	X	X	X	X	X	X	X
1C	Low Profile	51	X							
	High Profile			X	X	X	X	X	X	X

- L = No option
- D = With Diode between pin 2 and 6 (Pin 2 is positive)
- E = Internal shield on pin 9
- F = With Diode between pin 2 and 6 (Pin 2 is positive) and Internal shield on pin 9
- M = External magnetic shield
- Q = External magnetic shield and diode between pin 2 and 6 (Pin 2 is positive)
- R = External magnetic shield and internal shield on pin 9
- S = External magnetic shield and with diode between pin 2 and 6 (Pin 2 is positive) and internal shield on pin 9

RELAY DATA

All Data at 20° C	Switch Model --> Contact Form -->	Switch 72 Form A / B			Switch 75 Form A / B			Switch 90 Form C			Unit
		Min.	Typ.	Max.	Min.	Typ.	Max.	Min.	Typ.	Max.	
Switching Power	Any DC combination of V & A not to exceed their individual max.'s			20			10			3	W
Switching Voltage	DC or peak AC			200			1000			175	V
Switching Current	DC or peak AC			1.0			0.5			0.25	A
Carry Current	DC or peak AC			1.25			1.0			1.2	A
Static Contact Resistance	w/ 0.5 V & 10mA			150			200			150	mΩ
Dynamic Contact Resistance	Measured w/ 0.5 V & 50mA , 1.5 ms after closure			200			200			250	mΩ
Insulation Resistance across Contacts	100 volts applied	10 ¹² 10 ¹²			10 ¹² 10 ¹²			10 ⁹ 10 ¹²			Ω
Breakdown Voltage across Contact	Voltage applied for 60 sec. min.	320 1500*			1000** 1500*			200 1500			VDC
Operation Time incl. Bounce	Measured w/ 100 % overdrive			0.5			0.5			0.7	ms
Release Time	Measured w/ no coil suppression			0.1			0.1			1.5	ms
Capacitance	at 10 kHz cross contact		0.2 2.0			0.4 2.0			1.0 3.0		pF
Life Expectancies											
Switching 5 V - 10 mA	DC only & <10 pF stray cap.		1000			500			100		10 ⁶ Cycles
For other load requirements please see our life test section on P. 152.											
Environmental Data											
Shock Resistance	1/2 sinus wave duration 11 ms			50			50			30	g
Vibration Resistance	From 10 - 2000 Hz			20			20			10	g
Ambient Temperature	10°C/ minute max. allowable	-20		70	-20		70	-20		70	°C
Stock Temperature	10°C/ minute max. allowable	-35		95	-35		95	-35		95	°C
Soldering Temperature	5 sec.			260			260			260	°C

* Selects Pin out 13 and 425 kVDC (3.0 kVRMS) breakdown voltage contact to coil. **For higher voltage requirement please consult factory.

**Molded DIP
Reed Relays**

COIL DATA

Contact Form	Switch Model	Coil Voltage		Coil Resistance			Pull-in Voltage	Drop-out Voltage	Nominal Coil Power		
All Data at 20 °C		VDC		Ω			VDC	VDC	mW		
		Nom.	Max.	Min.	Typ.	Max.	Max.	Min.	Typ.		
1A	66 72 75	5	7.5	450 (180)	500 (200)	550 (220)	3.5	0.75	50		
		12	16	900	1000	1100	8.4	1.8	145		
		15	20	1800	2000	2200	10.5	2.2	115		
		24	30	1800	2000	2200	16.8	3.6	290		
1B **		66 72 75	5	7.5	450 (180)	500 (200)	550 (220)	3.5	0.75	50	
			12	16	900	1000	1100	8.4	1.8	145	
			15	20	1800	2000	2200	10.5	2.2	115	
			24	30	1800	2000	2200	16.8	3.6	290	
2A			66 72 75	5	7.5	180 (126)	200 (140)	220 (154)	3.5	0.75	125
				12	16	450	500	550	8.4	1.8	290
				15	20	1800	2000	2200	10.5	2.2	115
				24	30	1800	2000	2200	16.8	3.6	290
1C	90			5	7.5	180	200	220	3.5	0.75	125
				12	16	450	500	550	8.4	1.8	290
				15	20	1800	2000	2200	10.5	2.2	115
				24	30	1800	2000	2200	16.8	3.6	290

() Versions with magnetic shield.
 * The pull-in / drop-out voltage and coil resistance will change at rate of 0.4% per °C.
 ** Re-closure of Form B may occur if the max. coil voltage is exceeded. Coil polarity on Form B must be observed. Pin 2 is positive.