



MX29LV800C T/B

8M-BIT [1Mx8/512Kx16] CMOS SINGLE VOLTAGE 3V ONLY FLASH MEMORY

FEATURES

- Extended single - supply voltage range 2.7V to 3.6V
- 1,048,576 x 8/524,288 x 16 switchable
- Single power supply operation
 - 3.0V only operation for read, erase and program operation
- Fast access time: 55R/70/90ns
- Low power consumption
 - 30mA maximum active current
 - 0.2uA typical standby current
- Command register architecture
 - Byte/word Programming (9us/11us typical)
 - Sector Erase (Sector structure 16K-Bytex1, 8K-Bytex2, 32K-Bytex1, and 64K-Byte x15)
- **Fully compatible with MX29LV800BT/BB device**
- Auto Erase (chip & sector) and Auto Program
 - Automatically erase any combination of sectors with Erase Suspend capability.
 - Automatically program and verify data at specified address
- Erase suspend/Erase Resume
 - Suspends sector erase operation to read data from, or program data to, any sector that is not being erased, then resumes the erase.
- Status Reply
 - Data# polling & Toggle bit for detection of program and erase operation completion.
- Ready/Busy# pin (RY/BY#)
 - Provides a hardware method of detecting program or erase operation completion.
- Sector protection
 - Hardware method to disable any combination of sectors from program or erase operations
 - Temporary sector unprotected allows code changes in previously locked sectors.
- CFI (Common Flash Interface) compliant
 - Flash device parameters stored on the device and provide the host system to access
- 100,000 minimum erase/program cycles
- Latch-up protected to 100mA from -1V to VCC+1V
- Boot Sector Architecture
 - T = Top Boot Sector
 - B = Bottom Boot Sector
- Package type:
 - 44-pin SOP
 - 48-pin TSOP
 - 48-pin CSP
- Compatibility with JEDEC standard
 - Pinout and software compatible with single-power supply Flash
- 10 years data retention

GENERAL DESCRIPTION

The MX29LV800C T/B is a 8-mega bit Flash memory organized as 1M bytes of 8 bits or 512K words of 16 bits. MXIC's Flash memories offer the most cost-effective and reliable read/write non-volatile random access memory. The MX29LV800C T/B is packaged in 44-pin SOP, 48-pin TSOP, and 48-ball CSP. It is designed to be reprogrammed and erased in system or in standard EPROM programmers.

The standard MX29LV800C T/B offers access time as fast as 55ns, allowing operation of high-speed microprocessors without wait states. To eliminate bus contention, the MX29LV800C T/B has separate chip enable (CE#) and output enable (OE#) controls.

MXIC's Flash memories augment EPROM functionality with in-circuit electrical erasure and programming. The MX29LV800C T/B uses a command register to manage this functionality. The command register allows for 100%

TTL level control inputs and fixed power supply levels during erase and programming, while maintaining maximum EPROM compatibility.

MXIC Flash technology reliably stores memory contents even after 100,000 erase and program cycles. The MXIC cell is designed to optimize the erase and programming mechanisms. In addition, the combination of advanced tunnel oxide processing and low internal electric fields for erase and program operations produces reliable cycling. The MX29LV800C T/B uses a 2.7V~3.6V VCC supply to perform the High Reliability Erase and auto Program/Erase algorithms.

The highest degree of latch-up protection is achieved with MXIC's proprietary non-epi process. Latch-up protection is proved for stresses up to 100 milliamperes on address and data pin from -1V to VCC + 1V.



MX29LV800C T/B

PIN CONFIGURATIONS

44 SOP(500 mil)

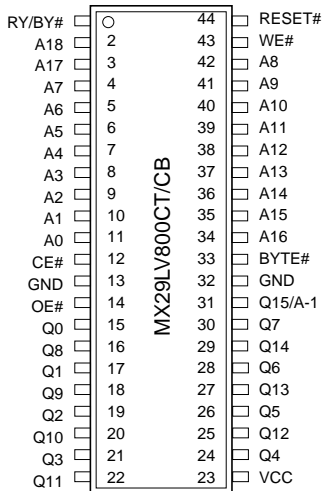

PIN DESCRIPTION

SYMBOL	PIN NAME
A0~A18	Address Input
Q0~Q14	Data Input/Output
Q15/A-1	Q15(Word mode)/LSB addr(Byte mode)
CE#	Chip Enable Input
WE#	Write Enable Input
BYTE#	Word/Byte Selection input
RESET#	Hardware Reset Pin
OE#	Output Enable Input
RY/BY#	Ready/Busy Output
VCC	Power Supply Pin (2.7V~3.6V)
GND	Ground Pin

48TSOP (Standard Type) (12mm x 20mm)

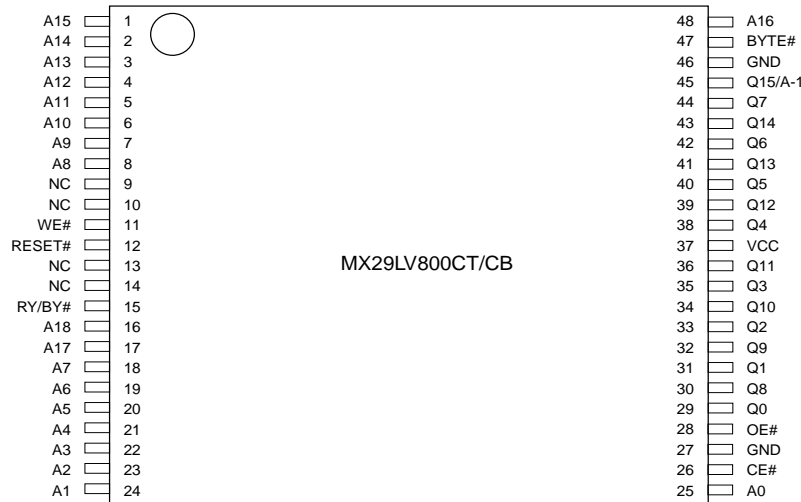

48-Ball CSP Ball Pitch = 0.8 mm, Top View, Balls Facing Down

	A	B	C	D	E	F	G	H
6	A13	A12	A14	A15	A16	BYTE#	Q15/A-1	GND
5	A9	A8	A10	A11	Q7	Q14	Q13	Q6
4	WE#	RESET#	NC	NC	Q5	Q12	Vcc	Q4
3	RY/BY#	NC	A18	NC	Q2	Q10	Q11	Q3
2	A7	A17	A6	A5	Q0	Q8	Q9	Q1
1	A3	A4	A2	A1	A0	CE#	OE#	GND



BLOCK STRUCTURE

TABLE 1: MX29LV800CT SECTOR ARCHITECTURE

Sector	Sector Size		Address range		Sector Address						
	Byte Mode	Word Mode	Byte Mode (x8)	Word Mode (x16)	A18	A17	A16	A15	A14	A13	A12
SA0	64Kbytes	32Kwords	00000h-0FFFFh	00000h-07FFFh	0	0	0	0	X	X	X
SA1	64Kbytes	32Kwords	10000h-1FFFFh	08000h-0FFFFh	0	0	0	1	X	X	X
SA2	64Kbytes	32Kwords	20000h-2FFFFh	10000h-17FFFh	0	0	1	0	X	X	X
SA3	64Kbytes	32Kwords	30000h-3FFFFh	18000h-1FFFFh	0	0	1	1	X	X	X
SA4	64Kbytes	32Kwords	40000h-4FFFFh	20000h-27FFFh	0	1	0	0	X	X	X
SA5	64Kbytes	32Kwords	50000h-5FFFFh	28000h-2FFFFh	0	1	0	1	X	X	X
SA6	64Kbytes	32Kwords	60000h-6FFFFh	30000h-37FFFh	0	1	1	0	X	X	X
SA7	64Kbytes	32Kwords	70000h-7FFFFh	38000h-3FFFFh	0	1	1	1	X	X	X
SA8	64Kbytes	32Kwords	80000h-8FFFFh	40000h-47FFFh	1	0	0	0	X	X	X
SA9	64Kbytes	32Kwords	90000h-9FFFFh	48000h-4FFFFh	1	0	0	1	X	X	X
SA10	64Kbytes	32Kwords	A0000h-AFFFFh	50000h-57FFFh	1	0	1	0	X	X	X
SA11	64Kbytes	32Kwords	B0000h-BFFFFh	58000h-5FFFFh	1	0	1	1	X	X	X
SA12	64Kbytes	32Kwords	C0000h-CFFFFh	60000h-67FFFh	1	1	0	0	X	X	X
SA13	64Kbytes	32Kwords	D0000h-DFFFFh	68000h-6FFFFh	1	1	0	1	X	X	X
SA14	64Kbytes	32Kwords	E0000h-EFFFFh	70000h-77FFFh	1	1	1	0	X	X	X
SA15	32Kbytes	16Kwords	F0000h-F7FFFh	78000h-7BFFFh	1	1	1	1	0	X	X
SA16	8Kbytes	4Kwords	F8000h-F9FFFh	7C000h-7CFFFh	1	1	1	1	1	0	0
SA17	8Kbytes	4Kwords	FA000h-FBFFFh	7D000h-7DFFFh	1	1	1	1	1	0	1
SA18	16Kbytes	8Kwords	FC000h-FFFFh	7E000h-7FFFFh	1	1	1	1	1	1	X

Note: Byte mode:address range A18:A-1, word mode:address range A18:A0.

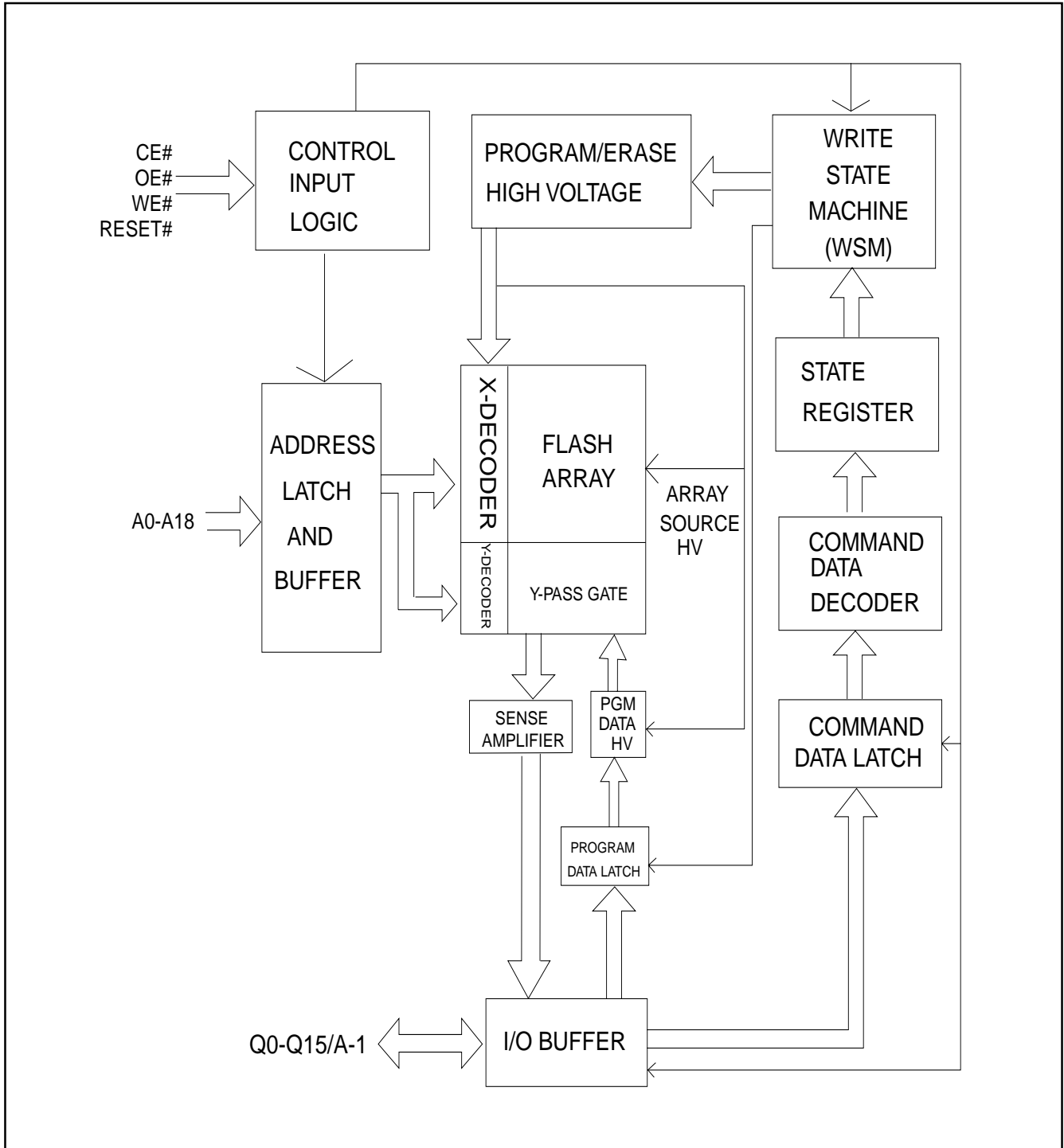

TABLE 2: MX29LV800CB SECTOR ARCHITECTURE

Sector	Sector Size		Address range		Sector Address						
	Byte Mode	Word Mode	Byte Mode (x8)	Word Mode (x16)	A18	A17	A16	A15	A14	A13	A12
SA0	16Kbytes	8Kwords	00000h-03FFFh	00000h-01FFFh	0	0	0	0	0	0	X
SA1	8Kbytes	4Kwords	04000h-05FFFh	02000h-02FFFh	0	0	0	0	0	1	0
SA2	8Kbytes	4Kwords	06000h-07FFFh	03000h-03FFFh	0	0	0	0	0	1	1
SA3	32Kbytes	16Kwords	08000h-0FFFFh	04000h-07FFFh	0	0	0	0	1	X	X
SA4	64Kbytes	32Kwords	10000h-1FFFFh	08000h-0FFFFh	0	0	0	1	X	X	X
SA5	64Kbytes	32Kwords	20000h-2FFFFh	10000h-17FFFh	0	0	1	0	X	X	X
SA6	64Kbytes	32Kwords	30000h-3FFFFh	18000h-1FFFFh	0	0	1	1	X	X	X
SA7	64Kbytes	32Kwords	40000h-4FFFFh	20000h-27FFFh	0	1	0	0	X	X	X
SA8	64Kbytes	32Kwords	50000h-5FFFFh	28000h-2FFFFh	0	1	0	1	X	X	X
SA9	64Kbytes	32Kwords	60000h-6FFFFh	30000h-37FFFh	0	1	1	0	X	X	X
SA10	64Kbytes	32Kwords	70000h-7FFFFh	38000h-3FFFFh	0	1	1	1	X	X	X
SA11	64Kbytes	32Kwords	80000h-8FFFFh	40000h-47FFFh	1	0	0	0	X	X	X
SA12	64Kbytes	32Kwords	90000h-9FFFFh	48000h-4FFFFh	1	0	0	1	X	X	X
SA13	64Kbytes	32Kwords	A0000h-AFFFFh	50000h-57FFFh	1	0	1	0	X	X	X
SA14	64Kbytes	32Kwords	B0000h-BFFFFh	58000h-5FFFFh	1	0	1	1	X	X	X
SA15	64Kbytes	32Kwords	C0000h-CFFFFh	60000h-67FFFh	1	1	0	0	X	X	X
SA16	64Kbytes	32Kwords	D0000h-DFFFFh	68000h-6FFFFh	1	1	0	1	X	X	X
SA17	64Kbytes	32Kwords	E0000h-EFFFFh	70000h-77FFFh	1	1	1	0	X	X	X
SA18	64Kbytes	32Kwords	F0000h-FFFFFh	78000h-7FFFFh	1	1	1	1	X	X	X

Note: Byte mode:address range A18:A-1, word mode:address range A18:A0.

BLOCK DIAGRAM





AUTOMATIC PROGRAMMING

The MX29LV800C T/B is byte programmable using the Automatic Programming algorithm. The Automatic Programming algorithm makes the external system do not need to have time out sequence nor to verify the data programmed. The typical chip programming time at room temperature of the MX29LV800C T/B is less than 10 seconds.

AUTOMATIC PROGRAMMING ALGORITHM

MXIC's Automatic Programming algorithm requires the user to only write program set-up commands (including 2 unlock write cycle and A0H) and a program command (program data and address). The device automatically times the programming pulse width, provides the program verification, and counts the number of sequences. A status bit similar to DATA# polling and a status bit toggling between consecutive read cycles, provide feedback to the user as to the status of the programming operation. Refer to write operation status, table 8, for more information on these status bits.

AUTOMATIC CHIP ERASE

The entire chip is bulk erased using 10 ms erase pulses according to MXIC's Automatic Chip Erase algorithm. Typical erasure at room temperature is accomplished in less than 25 second. The Automatic Erase algorithm automatically programs the entire array prior to electrical erase. The timing and verification of electrical erase are controlled internally within the device.

AUTOMATIC SECTOR ERASE

The MX29LV800C T/B is sector(s) erasable using MXIC's Auto Sector Erase algorithm. The Automatic Sector Erase algorithm automatically programs the specified sector(s) prior to electrical erase. The timing and verification of electrical erase are controlled internally within the device. An erase operation can erase one sector, multiple sectors, or the entire device.

AUTOMATIC ERASE ALGORITHM

MXIC's Automatic Erase algorithm requires the user to write commands to the command register using stan-

dard microprocessor write timings. The device will automatically pre-program and verify the entire array. Then the device automatically times the erase pulse width, provides the erase verification, and counts the number of sequences. A status bit toggling between consecutive read cycles provides feedback to the user as to the status of the erasing operation.

Register contents serve as inputs to an internal state-machine which controls the erase and programming circuitry. During write cycles, the command register internally latches address and data needed for the programming and erase operations. During a system write cycle, addresses are latched on the falling edge, and data are latched on the rising edge of WE# or CE#, whichever happens first.

MXIC's Flash technology combines years of EPROM experience to produce the highest levels of quality, reliability, and cost effectiveness. The MX29LV800C T/B electrically erases all bits simultaneously using Fowler-Nordheim tunneling. The bytes are programmed by using the EPROM programming mechanism of hot electron injection.

During a program cycle, the state-machine will control the program sequences and command register will not respond to any command set. During a Sector Erase cycle, the command register will only respond to Erase Suspend command. After Erase Suspend is completed, the device stays in read mode. After the state machine has completed its task, it will allow the command register to respond to its full command set.

AUTOMATIC SELECT

The auto select mode provides manufacturer and device identification, and sector protection verification, through identifier codes output on Q7~Q0. This mode is mainly adapted for programming equipment on the device to be programmed with its programming algorithm. When programming by high voltage method, automatic select mode requires VID (11.5V to 12.5V) on address pin A9 and other address pin A6, A1 and A0 as referring to Table 3. In addition, to access the automatic select codes in-system, the host can issue the automatic select command through the command register without requiring VID, as shown in table 5.

To verify whether or not sector being protected, the sector address must appear on the appropriate highest order



address bit (see Table 1 and Table 2). The rest of address bits, as shown in table 3, are don't care. Once all necessary bits have been set as required, the programming equipment may read the corresponding identifier code on Q7~Q0.

TABLE 3. MX29LV800C T/B AUTO SELECT MODE OPERATION

Description		Mode	CE#	OE#	WE#	A18	A11	A9	A8	A6	A5	A1	A0	Q15~Q0
						 A12	 A10		 A7		 A2			
Read Silicon ID	Manufacturer Code		L	L	H	X	X	VID	X	L	X	L	L	C2H
	Device ID (Top Boot Block)	Word	L	L	H	X	X	VID	X	L	X	L	H	22DAH
		Byte	L	L	H	X	X	VID	X	L	X	L	H	XXDAH
	Device ID (Bottom Boot Block)	Word	L	L	H	X	X	VID	X	L	X	L	H	225BH
Byte		L	L	H	X	X	VID	X	L	X	L	H	XX5BH	
Sector Protection Verification			L	L	H	SA	X	VID	X	L	X	H	L	XX01H (protected)
														XX00H (unprotected)

NOTE:SA=Sector Address, X=Don't Care, L=Logic Low, H=Logic High



QUERY COMMAND AND COMMON FLASH INTERFACE (CFI) MODE

MX29LV800C T/B is capable of operating in the CFI mode. This mode all the host system to determine the manufacturer of the device such as operating parameters and configuration. Two commands are required in CFI mode. Query command of CFI mode is placed first, then the Reset command exits CFI mode. These are described in Table 4.

The single cycle Query command is valid only when the device is in the Read mode, including Erase Suspend, Standby mode, and Read ID mode; however, it is ignored otherwise.

The Reset command exits from the CFI mode to the Read mode, or Erase Suspend mode, or read ID mode. The command is valid only when the device is in the CFI mode.

TABLE 4-1. CFI mode: Identification Data Values

(All values in these tables are in hexadecimal)

Description	Address	Address	Data
	(Byte Mode)	(Word Mode)	
Query-unique ASCII string "QRY"	20	10	0051
	22	11	0052
	24	12	0059
Primary vendor command set and control interface ID code	26	13	0002
	28	14	0000
Address for primary algorithm extended query table	2A	15	0040
	2C	16	0000
Alternate vendor command set and control interface ID code (none)	2E	17	0000
	30	18	0000
Address for secondary algorithm extended query table (none)	32	19	0000
	34	1A	0000

TABLE 4-2. CFI Mode: System Interface Data Values

(All values in these tables are in hexadecimal)

Description	Address	Address	Data
	(Byte Mode)	(Word Mode)	
VCC supply, minimum (2.7V)	36	1B	0027
VCC supply, maximum (3.6V)	38	1C	0036
VPP supply, minimum (none)	3A	1D	0000
VPP supply, maximum (none)	3C	1E	0000
Typical timeout for single word/byte write (2 ^N us)	3E	1F	0004
Typical timeout for Minimum size buffer write (2 ^N us)	40	20	0000
Typical timeout for individual block erase (2 ^N ms)	42	21	000A
Typical timeout for full chip erase (2 ^N ms)	44	22	0000
Maximum timeout for single word/byte write times (2 ^N X Typ)	46	23	0005
Maximum timeout for buffer write times (2 ^N X Typ)	48	24	0000
Maximum timeout for individual block erase times (2 ^N X Typ)	4A	25	0004
Maximum timeout for full chip erase times (not supported)	4C	26	0000



TABLE 4-3. CFI Mode: Device Geometry Data Values

(All values in these tables are in hexadecimal)

Description	Address	Address	Data
	(Byte Mode)	(Word Mode)	
Device size (2 ^N bytes)	4E	27	0014
Flash device interface code (refer to the CFI publication 100)	50	28	0002
	52	29	0000
Maximum number of bytes in multi-byte write (not supported)	54	2A	0000
	56	2B	0000
Number of erase block regions	58	2C	0004
Erase block region 1 information (refer to the CFI publication 100)	5A	2D	0000
	5C	2E	0000
	5E	2F	0040
	60	30	0000
Erase block region 2 information	62	31	0001
	64	32	0000
	66	33	0020
	68	34	0000
Erase block region 3 information	6A	35	0000
	6C	36	0000
	6E	37	0080
	70	38	0000
Erase block region 4 information	72	39	000E
	74	3A	0000
	76	3B	0000
	78	3C	0001

TABLE 4-4. CFI Mode: Primary Vendor-Specific Extended Query Data Values

(All values in these tables are in hexadecimal)

Description	Address	Address	Data
	(Byte Mode)	(Word Mode)	
Query-unique ASCII string "PRI"	80	40	0050
	82	41	0052
	84	42	0049
Major version number, ASCII	86	43	0031
Minor version number, ASCII	88	44	0030
Address sensitive unlock (0=required, 1= not required)	8A	45	0000
Erase suspend (2= to read and write)	8C	46	0002
Sector protect (N= # of sectors/group)	8E	47	0001
Temporary sector unprotected (1=supported)	90	48	0001
Sector protect/unprotected scheme	92	49	0004
Simultaneous R/W operation (0=not supported)	94	4A	0000
Burst mode type (0=not supported)	96	4B	0000
Page mode type (0=not supported)	98	4C	0000



TABLE 5. MX29LV800C T/B COMMAND DEFINITIONS

Command		Bus Cycle	First Bus Cycle		Second Bus Cycle		Third Bus Cycle		Fourth Bus Cycle		Fifth Bus Cycle		Sixth Bus Cycle	
			Addr	Data	Addr	Data	Addr	Data	Addr	Data	Addr	Data	Addr	Data
Reset		1	XXXH	F0H										
Read		1	RA	RD										
Read Silicon ID	Word	4	555H	AAH	2AAH	55H	555H	90H	ADI	DDI				
	Byte	4	AAAH	AAH	555H	55H	AAAH	90H	ADI	DDI				
Sector Protect Verify	Word	4	555H	AAH	2AAH	55H	555H	90H	(SA)	XX00H				
									x02H	XX01H				
	Byte	4	AAAH	AAH	555H	55H	AAAH	90H	(SA)	00H				
									x04H	01H				
Program	Word	4	555H	AAH	2AAH	55H	555H	A0H	PA	PD				
	Byte	4	AAAH	AAH	555H	55H	AAAH	A0H	PA	PD				
Chip Erase	Word	6	555H	AAH	2AAH	55H	555H	80H	555H	AAH	2AAH	55H	555H	10H
	Byte	6	AAAH	AAH	555H	55H	AAAH	80H	AAAH	AAH	555H	55H	AAAH	10H
Sector Erase	Word	6	555H	AAH	2AAH	55H	555H	80H	555H	AAH	2AAH	55H	SA	30H
	Byte	6	AAAH	AAH	555H	55H	AAAH	80H	AAAH	AAH	555H	55H	SA	30H
Sector Erase Suspend		1	XXXH	B0H										
Sector Erase Resume		1	XXXH	30H										
CFI Query	Word	1	55H	98										
	Byte	1	AAH	98										

Note:

- ADI = Address of Device identifier; A1=0, A0 = 0 for manufacturer code, A1=0, A0 = 1 for device code. A2-A18=do not care. (Refer to table 3)
 DDI = Data of Device identifier : C2H for manufacture code, 22DA/DA(Top), and 225B/5B(Bottom) for device code.
 X = X can be VIL or VIH
 RA=Address of memory location to be read.
 RD=Data to be read at location RA.
- PA = Address of memory location to be programmed.
 PD = Data to be programmed at location PA.
 SA = Address of the sector.
- The system should generate the following address patterns: 555H or 2AAH to Address A10~A0 in word mode/AAAH or 555H to Address A10~A-1 in byte mode.
 Address bit A11~A18=X=Don't care for all address commands except for Program Address (PA) and Sector Address (SA). Write Sequence may be initiated with A11~A18 in either state.
- For Sector Protect Verify operation: If read out data is 01H, it means the sector has been protected. If read out data is 00H, it means the sector is still not being protected.
- Any number of CFI data read cycle are permitted.



COMMAND DEFINITIONS

Device operations are selected by writing specific address and data sequences into the command register. Writing incorrect address and data values or writing them in the improper sequence will reset the device to the

read mode. Table 5 defines the valid register command sequences. Note that the Erase Suspend (B0H) and Erase Resume (30H) commands are valid only while the Sector Erase operation is in progress.

TABLE 6. MX29LV800C/T/B BUS OPERATION

DESCRIPTION	CE#	OE#	WE#	RESET#	ADDRESS								Q0~Q7	Q8~Q15	
					A18 A12	A10 A11	A9	A8 A7	A6	A5 A2	A1	A0		BYTE =VIH	BYTE =VIL
Read	L	L	H	H	AIN								Dout	Dout	Q8~Q14 =High Z Q15=A-1
Write	L	H	L	H	AIN								DIN(3)	DIN	
Reset	X	X	X	L	X								High Z	High Z	High Z
Temporary sector unlock	X	X	X	VID	AIN								DIN	DIN	High Z
Output Disable	L	H	H	H	X								High Z	High Z	High Z
Standby	Vcc± 0.3V	X	X	Vcc± 0.3V	X								High Z	High Z	High Z
Sector Protect	L	H	L	VID	SA	X	X	X	L	X	H	L	DIN	X	X
Chip Unprotected	L	H	L	VID	X	X	X	X	H	X	H	L	DIN	X	X
Sector Protection Verify	L	L	H	H	SA	X	VID	X	L	X	H	L	CODE(5)	X	X

NOTES:

1. Manufacturer and device codes may also be accessed via a command register write sequence. Refer to Table 5.
2. VID is the Silicon-ID-Read high voltage, 11.5V to 12.5V.
3. Refer to Table 5 for valid Data-In during a write operation.
4. X can be VIL or VIH.
5. Code=00H/XX00H means unprotected.
Code=01H/XX01H means protected.
6. A18~A12=Sector address for sector protect.
7. The sector protect and chip unprotected functions may also be implemented via programming equipment.

REQUIREMENTS FOR READING ARRAY DATA

To read array data from the outputs, the system must drive the CE# and OE# pins to VIL. CE# is the power control and selects the device. OE# is the output control and gates array data to the output pins. WE# should remain at VIH.

The internal state machine is set for reading array data upon device power-up, or after a hardware reset. This ensures that no spurious alteration of the memory content occurs during the power transition. No command is necessary in this mode to obtain array data. Standard microprocessor read cycles that assert valid address on the device address inputs produce valid data on the device data outputs. The device remains enabled for read access until the command register contents are altered.

WRITE COMMANDS/COMMAND SEQUENCES

To program data to the device or erase sectors of memory, the system must drive WE# and CE# to VIL, and OE# to VIH.

An erase operation can erase one sector, multiple sectors, or the entire device. Table indicates the address space that each sector occupies. A "sector address" consists of the address bits required to uniquely select a sector. The "Writing specific address and data commands or sequences into the command register initiates device operations. Table 1 defines the valid register command sequences. Writing incorrect address and data values or writing them in the improper sequence resets the device to reading array data. Section has details on erasing a sector or the entire chip, or suspending/resuming the erase operation.

After the system writes the autoselect command sequence, the device enters the autoselect mode. The system can then read autoselect codes from the internal register (which is separate from the memory array) on Q7-Q0. Standard read cycle timings apply in this mode. Refer to the Autoselect Mode and Autoselect Command Sequence section for more information.

ICC2 in the DC Characteristics table represents the active current specification for the write mode. The "AC Characteristics" section contains timing specification table and timing diagrams for write operations.

STANDBY MODE

When using both pins of CE# and RESET#, the device enter CMOS Standby with both pins held at $V_{CC} \pm 0.3V$. If CE# and RESET# are held at VIH, but not within the range of $V_{CC} \pm 0.3V$, the device will still be in the standby mode, but the standby current will be larger. During Auto Algorithm operation, V_{CC} active current (I_{CC2}) is required even CE# = "H" until the operation is completed. The device can be read with standard access time (t_{CE}) from either of these standby modes, before it is ready to read data.

OUTPUT DISABLE

With the OE# input at a logic high level (VIH), output from the devices are disabled. This will cause the output pins to be in a high impedance state.

RESET# OPERATION

The RESET# pin provides a hardware method of resetting the device to reading array data. When the RESET# pin is driven low for at least a period of t_{RP} , the device immediately terminates any operation in progress, tri-states all output pins, and ignores all read/write commands for the duration of the RESET# pulse. The device also resets the internal state machine to reading array data. The operation that was interrupted should be reinitiated once the device is ready to accept another command sequence, to ensure data integrity

Current is reduced for the duration of the RESET# pulse. When RESET# is held at $V_{SS} \pm 0.3V$, the device draws CMOS standby current (I_{CC4}). If RESET# is held at VIL but not within $V_{SS} \pm 0.3V$, the standby current will be greater.

The RESET# pin may be tied to system reset circuitry. A system reset would that also reset the Flash memory, enabling the system to read the boot-up firmware from the Flash memory.

If RESET# is asserted during a program or erase operation, the RY/BY# pin remains a "0" (busy) until the internal reset operation is complete, which requires a time of t_{READY} (during Embedded Algorithms). The system can thus monitor RY/BY# to determine whether the reset operation is complete. If RESET# is asserted when a pro-

gram or erase operation is completed within a time of t_{READY} (not during Embedded Algorithms). The system can read data t_{RH} after the RESET\# pin returns to VIH .

Refer to the AC Characteristics tables for RESET\# parameters and to Figure 22 for the timing diagram.

READ/RESET COMMAND

The read or reset operation is initiated by writing the read/reset command sequence into the command register. Microprocessor read cycles retrieve array data. The device remains enabled for reads until the command register contents are altered.

If program-fail or erase-fail happen, the write of F0H will reset the device to abort the operation. A valid command must then be written to place the device in the desired state.

SILICON-ID READ COMMAND

Flash memories are intended for use in applications where the local CPU alters memory contents. As such, manufacturer and device codes must be accessible while the device resides in the target system. PROM programmers typically access signature codes by raising A9 to a high voltage (VID). However, multiplexing high voltage onto address lines is not generally desired system design practice.

The MX29LV800C T/B contains a Silicon-ID-Read operation to supple traditional PROM programming methodology. The operation is initiated by writing the read silicon ID command sequence into the command register. Following the command write, a read cycle with $\text{A1}=\text{VIL}$, $\text{A0}=\text{VIL}$ retrieves the manufacturer code of $\text{C2H}/\text{00C2H}$. A read cycle with $\text{A1}=\text{VIL}$, $\text{A0}=\text{VIH}$ returns the device code of $\text{DAH}/\text{22DAH}$ for MX29LV800CT, $\text{5BH}/\text{225BH}$ for MX29LV800CB.

SET-UP AUTOMATIC CHIP/SECTOR ERASE COMMANDS

Chip erase is a six-bus cycle operation. There are two "unlock" write cycles. These are followed by writing the "set-up" command 80H . Two more "unlock" write cycles are then followed by the chip erase command 10H or sector erase command 30H .

The Automatic Chip Erase does not require the device to be entirely pre-programmed prior to executing the Automatic Chip Erase. Upon executing the Automatic Chip Erase, the device will automatically program and verify the entire memory for an all-zero data pattern. When the device is automatically verified to contain an all-zero pattern, a self-timed chip erase and verify begin. The erase and verify operations are completed when the data on Q7 is "1" at which time the device returns to the Read mode. The system is not required to provide any control or timing during these operations.

When using the Automatic Chip Erase algorithm, note that the erase automatically terminates when adequate erase margin has been achieved for the memory array (no erase verification command is required).

If the Erase operation was unsuccessful, the data on Q5 is "1" (see Table 8), indicating the erase operation exceed internal timing limit.

The automatic erase begins on the rising edge of the last WE\# or CE\# pulse, whichever happens first in the command sequence and terminates when the data on Q7 is "1" at which time the device returns to the Read mode, or the data on Q6 stops toggling for two consecutive read cycles at which time the device returns to the Read mode.

TABLE 7. SILICON ID CODE

Pins		A0	A1	Q15~Q8	Q7	Q6	Q5	Q4	Q3	Q2	Q1	Q0	Code (Hex)
Manufacture code	Word	VIL	VIL	00H	1	1	0	0	0	0	1	0	00C2H
	Byte	VIL	VIL	X	1	1	0	0	0	0	1	0	C2H
Device code for MX29LV800CT	Word	VIH	VIL	22H	1	1	0	1	1	0	1	0	22DAH
	Byte	VIH	VIL	X	1	1	0	1	1	0	1	0	DAH
Device code for MX29LV800CB	Word	VIH	VIL	22H	0	1	0	1	1	0	1	1	225BH
	Byte	VIH	VIL	X	0	1	0	1	1	0	1	1	5BH
Sector Protection Verification	Word	X	VIH	X	0	0	0	0	0	0	0	1	01H (Protected)
	Byte	X	VIH	X	0	0	0	0	0	0	0	0	00H (Unprotected)

READING ARRAY DATA

The device is automatically set to reading array data after device power-up. No commands are required to retrieve data. The device is also ready to read array data after completing an Automatic Program or Automatic Erase algorithm.

After the device accepts an Erase Suspend command, the device enters the Erase Suspend mode. The system can read array data using the standard read timings, except that if it reads at an address within erase-suspended sectors, the device outputs status data. After completing a programming operation in the Erase Suspend mode, the system may once again read array data with the same exception. See "Erase Suspend/Erase Resume Commands" for more information on this mode. The system must issue the reset command to re-enable the device for reading array data if Q5 goes high, or while in the autoselect mode. See the "Reset Command" section, next.

RESET COMMAND

Writing the reset command to the device resets the device to reading array data. Address bits are don't care for this command.

The reset command may be written between the sequence cycles in an erase command sequence before erasing begins. This resets the device to reading array data. Once erasure begins, however, the device ignores reset commands until the operation is complete.

The reset command may be written between the sequence cycles in a program command sequence before programming begins. This resets the device to reading array data (also applies to programming in Erase Suspend mode). Once programming begins, however, the device ignores reset commands until the operation is complete.

The reset command may be written between the sequence cycles in an SILICON ID READ command sequence. Once in the SILICON ID READ mode, the reset command must be written to return to reading array data (also applies to SILICON ID READ during Erase Suspend).

If Q5 goes high during a program or erase operation, writing the reset command returns the device to reading array data (also applies during Erase Suspend).

SECTOR ERASE COMMANDS

The Automatic Sector Erase does not require the device to be entirely pre-programmed prior to executing the Automatic Sector Erase Set-up command and Automatic Sector Erase command. Upon executing the Automatic Sector Erase command, the device will automatically program and verify the sector(s) memory for an all-zero data pattern. The system is not required to provide any control or timing during these operations.

When the sector(s) is automatically verified to contain an all-zero pattern, a self-timed sector erase and verify begin. The erase and verify operations are complete when either the data on Q7 is "1" at which time the device returns to the Read mode, or the data on Q6 stops toggling for two consecutive read cycles at which time the device returns to the Read mode. The system is not required to provide any control or timing during these operations.

When using the Automatic sector Erase algorithm, note that the erase automatically terminates when adequate erase margin has been achieved for the memory array (no erase verification command is required). Sector erase is a six-bus cycle operation. There are two "unlock" write cycles. These are followed by writing the set-up command 80H. Two more "unlock" write cycles are then followed by the sector erase command 30H. The sector address is latched on the falling edge of WE# or CE#, whichever happens later, while the command (data) is latched on the rising edge of WE# or CE#, whichever happens first. Sector addresses selected are loaded into internal register on the sixth falling edge of WE# or CE#, whichever happens later. Each successive sector load cycle started by the falling edge of WE# or CE#, whichever happens later must begin within 50us from the rising edge of the preceding WE# or CE#, whichever happens first. Otherwise, the loading period ends and internal auto sector erase cycle starts. (Monitor Q3 to determine if the sector erase timer window is still open, see section Q3, Sector Erase Timer.) Any command other than Sector Erase (30H) or Erase Suspend (B0H) during the time-out period resets the device to read mode.

ERASE SUSPEND

This command only has meaning while the state machine is executing Automatic Sector Erase operation, and therefore will only be responded during Automatic Sector Erase operation. When the Erase Suspend Command is

issued during the sector erase operation, the device requires a maximum 20us to suspend the sector erase operation. However, when the Erase Suspend command is written during the sector erase time-out, the device immediately terminates the time-out period and suspends the erase operation. After this command has been executed, the command register will initiate erase suspend mode. The state machine will return to read mode automatically after suspend is ready. At this time, state machine only allows the command register to respond to Erase Resume, program data to , or read data from any sector not selected for erasure.

The system can determine the status of the program operation using the Q7 or Q6 status bits, just as in the standard program operation. After an erase-suspend program operation is complete, the system can once again read array data within non-suspended sectors.

ERASE RESUME

This command will cause the command register to clear the suspend state and return back to Sector Erase mode but only if an Erase Suspend command was previously issued. Erase Resume will not have any effect in all other conditions. Another Erase Suspend command can be written after the chip has resumed erasing. However, a delay time must be required after the erase resume command (1.5ms for MX29LV800C T/B), if the system implements an endless erase suspend/resume loop, or the number of erase suspend/resume is exceeded 1024 times. The erase times will be expended if the erase behavior always be suspended. (Please refer to MXIC Flash Application Note for details.)

WORD/BYTE PROGRAM COMMAND SEQUENCE

The device programs one byte of data for each program operation. The command sequence requires four bus cycles, and is initiated by writing two unlock write cycles, followed by the program set-up command. The program address and data are written next, which in turn initiate the Embedded Program algorithm. The system is not required to provide further controls or timings. The device automatically generates the program pulses and verifies the programmed cell margin. Table 1 shows the address and data requirements for the byte program command sequence.

When the Embedded Program algorithm is complete, the

device then returns to reading array data and addresses are no longer latched. The system can determine the status of the program operation by using Q7, Q6, or RY/BY#. See "Write Operation Status" for information on these status bits.

Any commands written to the device during the Embedded Program Algorithm are ignored. Note that a hardware reset immediately terminates the programming operation. The Byte Program command sequence should be reinitiated once the device has reset to reading array data, to ensure data integrity.

Programming is allowed in any sequence and across sector boundaries. A bit cannot be programmed from a "0" back to a "1". Attempting to do so may halt the operation and set Q5 to "1", or cause the DATA# polling algorithm to indicate the operation was successful. However, a succeeding read will show that the data is still "0". Only erase operations can convert a "0" to a "1".

WRITE OPERATION STATUS

The device provides several bits to determine the status of a write operation: Q2, Q3, Q5, Q6, Q7, and RY/BY#. Table 10 and the following subsections describe the functions of these bits. Q7, RY/BY#, and Q6 each offer a method for determining whether a program or erase operation is complete or in progress. These three bits are discussed first.

Q7: Data# Polling

The DATA# polling bit, Q7, indicates to the host system whether an Automatic Algorithm is in progress or completed, or whether the device is in Erase Suspend. DATA# polling is valid after the rising edge of the final WE# pulse in the program or erase command sequence.

During the Automatic Program algorithm, the device outputs on Q7 the complement of the datum programmed to Q7. This Q7 status also applies to programming during Erase Suspend. When the Automatic Program algorithm is complete, the device outputs the datum programmed to Q7. The system must provide the program address to read valid status information on Q7. If a program address falls within a protected sector, DATA# polling on Q7 is active for approximately 1 us, then the device returns to reading array data.

During the Automatic Erase algorithm, DATA# polling produces a "0" on Q7. When the Automatic Erase algorithm is complete, or if the device enters the Erase Suspend mode, DATA# polling produces a "1" on Q7. This is analogous to the complement/true datum output described for the Automatic Program algorithm: the erase function changes all the bits in a sector to "1" prior to this, the device outputs the "complement," or "0". The system must provide an address within any of the sectors selected for erasure to read valid status information on Q7.

After an erase command sequence is written, if all sectors selected for erasing are protected, DATA# polling on Q7 is active for approximately 100 us, then the device returns to reading array data. If not all selected sectors are protected, the Automatic Erase algorithm erases the unprotected sectors, and ignores the selected sectors that are protected.

When the system detects Q7 has changed from the complement to true data, it can read valid data at Q7-Q0 on the following read cycles. This is because Q7 may change asynchronously with Q0-Q6 while Output Enable (OE#) is asserted low.

RY/BY# : Ready/Busy

The RY/BY# is a dedicated, open-drain output pin that indicates whether an Automatic Erase/Program algorithm is in progress or complete. The RY/BY# status is valid after the rising edge of the final WE# or CE#, whichever happens first, in the command sequence. Since RY/BY# is an open-drain output, several RY/BY# pins can be tied together in parallel with a pull-up resistor to VCC.

If the output is low (Busy), the device is actively erasing or programming. (This includes programming in the Erase Suspend mode.) If the output is high (Ready), the device is ready to read array data (including during the Erase Suspend mode), or is in the standby mode.

Table 8 shows the outputs for RY/BY# during write operation.

Q6:Toggle BIT I

Toggle Bit I on Q6 indicates whether an Automatic Program or Erase algorithm is in progress or complete, or whether the device has entered the Erase Suspend mode. Toggle Bit I may be read at any address, and is valid

after the rising edge of the final WE# or CE#, whichever happens first, in the command sequence (prior to the program or erase operation), and during the sector timeout.

During an Automatic Program or Erase algorithm operation, successive read cycles to any address cause Q6 to toggle. The system may use either OE# or CE# to control the read cycles. When the operation is complete, Q6 stops toggling.

After an erase command sequence is written, if all sectors selected for erasing are protected, Q6 toggles and returns to reading array data. If not all selected sectors are protected, the Automatic Erase algorithm erases the unprotected sectors, and ignores the selected sectors that are protected.

The system can use Q6 and Q2 together to determine whether a sector is actively erasing or is erase suspended. When the device is actively erasing (that is, the Automatic Erase algorithm is in progress), Q6 toggling. When the device enters the Erase Suspend mode, Q6 stops toggling. However, the system must also use Q2 to determine which sectors are erasing or erase-suspended. Alternatively, the system can use Q7.

If a program address falls within a protected sector, Q6 toggles for approximately 2 us after the program command sequence is written, then returns to reading array data.

Q6 also toggles during the erase-suspend-program mode, and stops toggling once the Automatic Program algorithm is complete.

Table 8 shows the outputs for Toggle Bit I on Q6.

Q2:Toggle Bit II

The "Toggle Bit II" on Q2, when used with Q6, indicates whether a particular sector is actively erasing (that is, the Automatic Erase algorithm is in process), or whether that sector is erase-suspended. Toggle Bit II is valid after the rising edge of the final WE# or CE#, whichever happens first, in the command sequence.

Q2 toggles when the system reads at addresses within those sectors that have been selected for erasure. (The system may use either OE# or CE# to control the read

cycles.) But Q2 cannot distinguish whether the sector is actively erasing or is erase-suspended. Q6, by comparison, indicates whether the device is actively erasing, or is in Erase Suspend, but cannot distinguish which sectors are selected for erasure. Thus, both status bits are required for sectors and mode information. Refer to Table 8 to compare outputs for Q2 and Q6.

Reading Toggle Bits Q6/ Q2

Whenever the system initially begins reading toggle bit status, it must read Q7-Q0 at least twice in a row to determine whether a toggle bit is toggling. Typically, the system would note and store the value of the toggle bit after the first read. After the second read, the system would compare the new value of the toggle bit with the first. If the toggle bit is not toggling, the device has completed the program or erase operation. The system can read array data on Q7-Q0 on the following read cycle.

However, if after the initial two read cycles, the system determines that the toggle bit is still toggling, the system also should note whether the value of Q5 is high (see the section on Q5). If it is, the system should then determine again whether the toggle bit is toggling, since the toggle bit may have stopped toggling just as Q5 went high. If the toggle bit is no longer toggling, the device has successfully completed the program or erase operation. If it is still toggling, the device did not complete the operation successfully, and the system must write the reset command to return to reading array data.

The remaining scenario is that system initially determines that the toggle bit is toggling and Q5 has not gone high. The system may continue to monitor the toggle bit and Q5 through successive read cycles, determining the status as described in the previous paragraph. Alternatively, it may choose to perform other system tasks. In this case, the system must start at the beginning of the algorithm when it returns to determine the status of the operation.

Q5 Exceeded Timing Limits

Q5 will indicate if the program or erase time has exceeded the specified limits (internal pulse count). Under these conditions Q5 will produce a "1". This time-out condition indicates that the program or erase cycle was not suc-

cessfully completed. Data# Polling and Toggle Bit are the only operating functions of the device under this condition.

If this time-out condition occurs during sector erase operation, it specifies that a particular sector is bad and it may not be reused. However, other sectors are still functional and may be used for the program or erase operation. The device must be reset to use other sectors. Write the Reset command sequence to the device, and then execute program or erase command sequence. This allows the system to continue to use the other active sectors in the device.

If this time-out condition occurs during the chip erase operation, it specifies that the entire chip is bad or combination of sectors are bad.

If this time-out condition occurs during the byte programming operation, it specifies that the entire sector containing that byte is bad and this sector may not be reused, (other sectors are still functional and can be reused).

The time-out condition will not appear if a user tries to program a non blank location without erasing. Please note that this is not a device failure condition since the device was incorrectly used.

TABLE 8. WRITE OPERATION STATUS

Status		Q7 (Note1)	Q6	Q5 (Note2)	Q3	Q2	RY/BY#	
In Progress	Byte Program in Auto Program Algorithm	Q7#	Toggle	0	N/A	No Toggle	0	
	Auto Erase Algorithm	0	Toggle	0	1	Toggle	0	
	Erase Suspended Mode	Erase Suspend Read (Erase Suspended Sector)	1	No Toggle	0	N/A	Toggle	1
		Erase Suspend Read (Non-Erase Suspended Sector)	Data	Data	Data	Data	Data	1
Erase Suspend Program		Q7#	Toggle	0	N/A	N/A	0	
Exceeded Time Limits	Byte Program in Auto Program Algorithm	Q7#	Toggle	1	N/A	No Toggle	0	
	Auto Erase Algorithm	0	Toggle	1	1	Toggle	0	
	Erase Suspend Program	Q7#	Toggle	1	N/A	N/A	0	

Note:

1. Q7 and Q2 require a valid address when reading status information. Refer to the appropriate subsection for further details.
2. Q5 switches to '1' when an Auto Program or Auto Erase operation has exceeded the maximum timing limits.
See "Q5:Exceeded Timing Limits " for more information.

Q3**Sector Erase Timer**

After the completion of the initial sector erase command sequence, the sector erase time-out will begin. Q3 will remain low until the time-out is complete. DATA# polling and Toggle Bit are valid after the initial sector erase command sequence.

If DATA# polling or the Toggle Bit indicates the device has been written with a valid erase command, Q3 may be used to determine if the sector erase timer window is still open. If Q3 is high ("1") the internally controlled erase cycle has begun; attempts to write subsequent commands to the device will be ignored until the erase operation is completed as indicated by DATA# polling or Toggle Bit. If Q3 is low ("0"), the device will accept additional sector erase commands. To insure the command has been accepted, the system software should check the status of Q3 prior to and following each subsequent sector erase command. If Q3 were high on the second status check, the command may not have been accepted.

DATA PROTECTION

The MX29LV800C T/B is designed to offer protection against accidental erasure or programming caused by spurious system level signals that may exist during power transition. During power up the device automatically resets the state machine in the Read mode. In addition, with its control register architecture, alteration of the memory contents only occurs after successful completion of specific command sequences. The device also incorporates several features to prevent inadvertent write cycles resulting from VCC power-up and power-down transition or system noise.

WRITE PULSE "GLITCH" PROTECTION

Noise pulses of less than 5ns(typical) on CE# or WE# will not initiate a write cycle.

LOGICAL INHIBIT

Writing is inhibited by holding any one of OE# = VIL, CE# = VIH or WE# = VIH. To initiate a write cycle CE# and WE# must be a logical zero while OE# is a logical one.

POWER SUPPLY DECOUPLING

In order to reduce power switching effect, each device should have a 0.1uF ceramic capacitor connected between its VCC and GND.

POWER-UP SEQUENCE

The MX29LV800C T/B powers up in the Read only mode. In addition, the memory contents may only be altered after successful completion of the predefined command sequences.

TEMPORARY SECTOR UNPROTECTED

This feature allows temporary unprotected of previously protected sector to change data in-system. The Temporary Sector Unprotected mode is activated by setting the RESET# pin to VID(11.5V-12.5V). During this mode, formerly protected sectors can be programmed or erased as un-protected sector. Once VID is remove from the RESET# pin, all the previously protected sectors are protected again.

SECTOR PROTECTION

The MX29LV800C T/B features hardware sector protection. This feature will disable both program and erase operations for these sectors protected. To activate this mode, the programming equipment must force VID on address pin A9 and OE# (suggest VID = 12V). Programming of the protection circuitry begins on the falling edge of the WE# pulse and is terminated on the rising edge. Please refer to sector protect algorithm and waveform.

To verify programming of the protection circuitry, the programming equipment must force VID on address pin A9 (with CE# and OE# at VIL and WE# at VIH). When A1=VIH, A0=VIL, A6=VIL, it will produce a logical "1" code at device output Q0 for a protected sector. Otherwise the device will produce 00H for the unprotected sector. In this mode, the addresses, except for A1, are don't care. Address locations with A1 = VIL are reserved to read manufacturer and device codes. (Read Silicon ID)

It is also possible to determine if the sector is protected in the system by writing a Read Silicon ID command.



Performing a read operation with A1=VIH, it will produce a logical "1" at Q0 for the protected sector.

CHIP UNPROTECTED

The MX29LV800C T/B also features the chip unprotected mode, so that all sectors are unprotected after chip unprotected is completed to incorporate any changes in the code. It is recommended to protect all sectors before activating chip unprotected mode.

To activate this mode, the programming equipment must force VID on control pin OE# and address pin A9. The CE# pins must be set at VIL. Pins A6 must be set to VIH. Refer to chip unprotected algorithm and waveform for the chip unprotected algorithm. The unprotection mechanism begins on the falling edge of the WE# pulse and is terminated on the rising edge.

It is also possible to determine if the chip is unprotected in the system by writing the Read Silicon ID command. Performing a read operation with A1=VIH, it will produce 00H at data outputs (Q0-Q7) for an unprotected sector.

It is noted that all sectors are unprotected after the chip unprotected algorithm is completed.



ABSOLUTE MAXIMUM RATINGS

Storage Temperature
Plastic Packages -65°C to +150°C
Ambient Temperature
with Power Applied. -65°C to +125°C
Voltage with Respect to Ground
VCC (Note 1) -0.5 V to +4.0 V
A9, OE#, and
RESET# (Note 2) -0.5 V to +12.5 V
All other pins (Note 1) -0.5 V to VCC +0.5 V
Output Short Circuit Current (Note 3) 200 mA

Notes:

1. Minimum DC voltage on input or I/O pins is -0.5 V. During voltage transitions, input or I/O pins may overshoot VSS to -2.0 V for periods of up to 20 ns. See Figure 6. Maximum DC voltage on input or I/O pins is VCC +0.5 V. During voltage transitions, input or I/O pins may overshoot to VCC +2.0 V for periods up to 20 ns.
2. Minimum DC input voltage on pins A9, OE#, and RESET# is -0.5 V. During voltage transitions, A9, OE#, and RESET# may overshoot VSS to -2.0 V for periods of up to 20 ns. See Figure 6. Maximum DC input voltage on pin A9 is +12.5 V which may overshoot to 14.0 V for periods up to 20 ns.
3. No more than one output may be shorted to ground at a time. Duration of the short circuit should not be greater than one second.

Stresses above those listed under "Absolute Maximum Ratings" may cause permanent damage to the device. This is a stress rating only; functional operation of the device at these or any other conditions above those indicated in the operational sections of this data sheet is not implied. Exposure of the device to absolute maximum rating conditions for extended periods may affect device reliability.

OPERATING RATINGS

Commercial (C) Devices

Ambient Temperature (T_A) 0° C to +70° C

Industrial (I) Devices

Ambient Temperature (T_A) -40° C to +85° C

Vcc Supply Voltages

Vcc for full voltage range. +2.7 V to 3.6 V

Operating ranges define those limits between which the functionality of the device is guaranteed.



CAPACITANCE TA = 25°C, f = 1.0 MHz

SYMBOL	PARAMETER	MIN.	TYP	MAX.	UNIT	CONDITIONS
CIN1	Input Capacitance			8	pF	VIN = 0V
CIN2	Control Pin Capacitance			12	pF	VIN = 0V
COUT	Output Capacitance			12	pF	VOUT = 0V

TABLE 9. DC CHARACTERISTICS TA = -40°C to 85°C, VCC = 2.7V~3.6V

Symbol	PARAMETER	MIN.	TYP	MAX.	UNIT	CONDITIONS
ILI	Input Leakage Current			± 1	uA	VIN = VSS to VCC
ILIT	A9 Input Leakage Current			35	uA	VCC=VCC max; A9=12.5V
ILO	Output Leakage Current			± 1	uA	VOUT = VSS to VCC, VCC=VCC max
ICC1	VCC Active Read Current		7	12	mA	CE#=VIL, OE#=VIH @5MHz
			2	4	mA	(Byte Mode) @1MHz
			7	12	mA	CE#=VIL, OE#=VIH @5MHz
			2	4	mA	(Word Mode) @1MHz
ICC2	VCC Active write Current		15	30	mA	CE#=VIL, OE#=VIH
ICC3	VCC Standby Current		0.2	5	uA	CE#; RESET#=VCC ± 0.3V
ICC4	VCC Standby Current During Reset		0.2	5	uA	RESET#=VSS ± 0.3V
ICC5	Automatic sleep mode		0.2	5	uA	VIH=VCC ± 0.3V; VIL=VSS ± 0.3V
VIL	Input Low Voltage(Note 1)	-0.5		0.8	V	
VIH	Input High Voltage	0.7xVCC		VCC+ 0.3	V	
VID	Voltage for Automatic Select and Temporary Sector Unprotected	11.5		12.5	V	VCC=3.3V
VOL	Output Low Voltage			0.45	V	IOL = 4.0mA, VCC= VCC min
VOH1	Output High Voltage(TTL)	0.85xVCC				IOH = -2mA, VCC=VCC min
VOH2	Output High Voltage (CMOS)	VCC-0.4				IOH = -100uA, VCC min

NOTES:

- VIL min. = -1.0V for pulse width is equal to or less than 50 ns.
VIL min. = -2.0V for pulse width is equal to or less than 20 ns.
- VIH max. = VCC + 1.5V for pulse width is equal to or less than 20 ns
If VIH is over the specified maximum value, read operation cannot be guaranteed.
- Automatic sleep mode enable the low power mode when addresses remain stable for tACC +30ns.



AC CHARACTERISTICS TA = -40°C to 85°C, VCC = 2.7V~3.6V

TABLE 10. READ OPERATIONS

SYMBOL	PARAMETER	29LV800C-55R		29LV800C-70		29LV800C-90		UNIT	CONDITIONS
		MIN.	MAX.	MIN.	MAX.	MIN.	MAX.		
tRC	Read Cycle Time (Note 1)	55		70		90		ns	
tACC	Address to Output Delay		55		70		90	ns	CE#=OE#=VIL
tCE	CE# to Output Delay		55		70		90	ns	OE#=VIL
tOE	OE# to Output Delay		30		30		35	ns	CE#=VIL
tDF	OE# High to Output Float (Note1)	0	25	0	25	0	30	ns	CE#=VIL
tOEH	Output Enable	Read	0	0	0	0		ns	
		Hold Time	Toggle and	10	10	10		ns	
			Data# Polling						
tOH	Address to Output hold	0		0		0		ns	CE#=OE#=VIL

TEST CONDITIONS:

- Input pulse levels: 0V/3.0V.
- Input rise and fall times is equal to or less than 5ns.
- Output load: 1 TTL gate + 100pF (Including scope and jig), for 29LV800C T/B-90. 1 TTL gate + 30pF (Including scope and jig) for 29LV800C T/B-70
- Reference levels for measuring timing: 1.5V.

NOTES:

1. Not 100% tested.
2. tDF is defined as the time at which the output achieves the open circuit condition and data is no longer driven.

SWITCHING TEST CIRCUITS

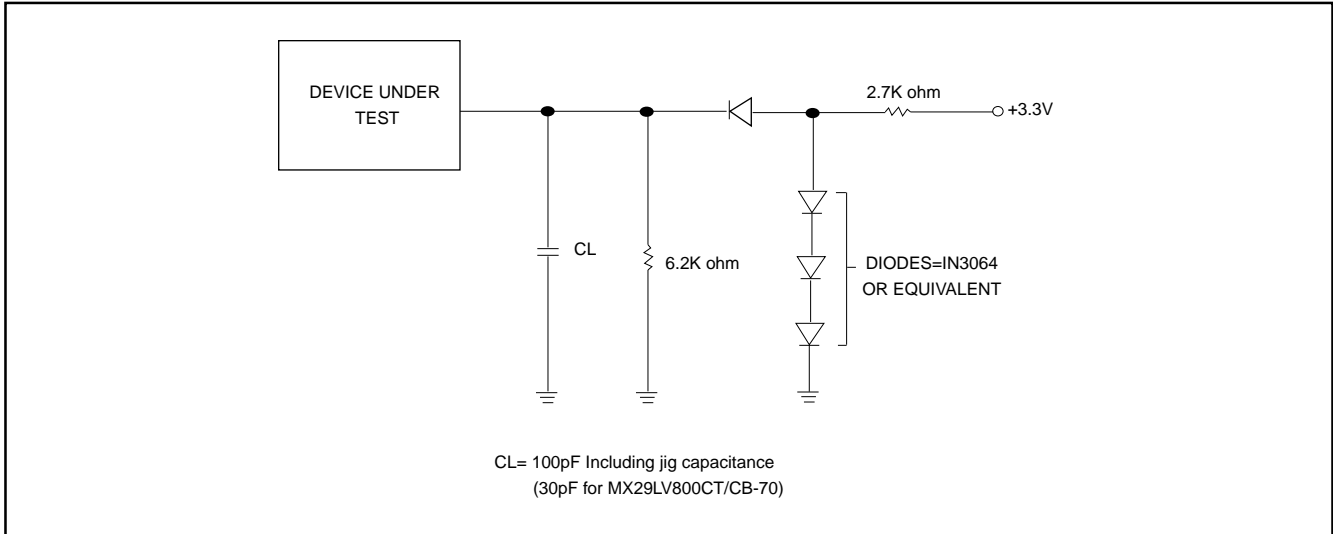

SWITCHING TEST WAVEFORMS

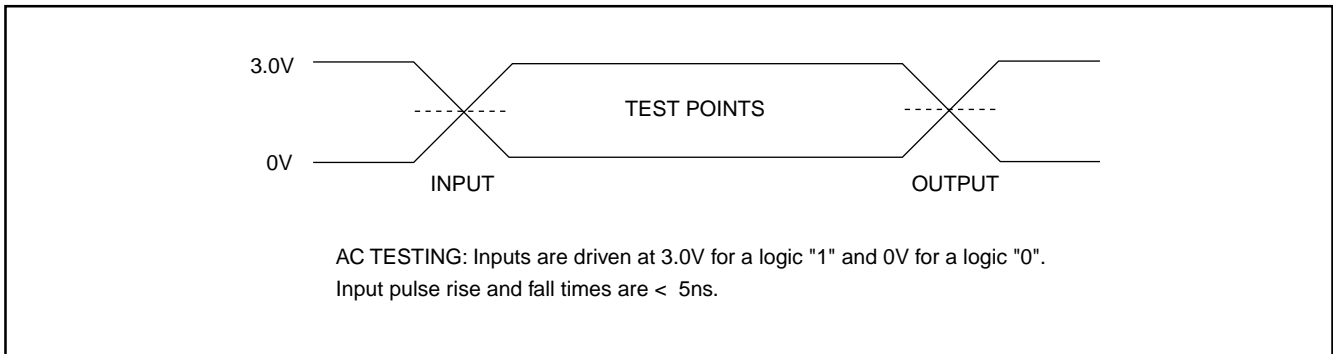
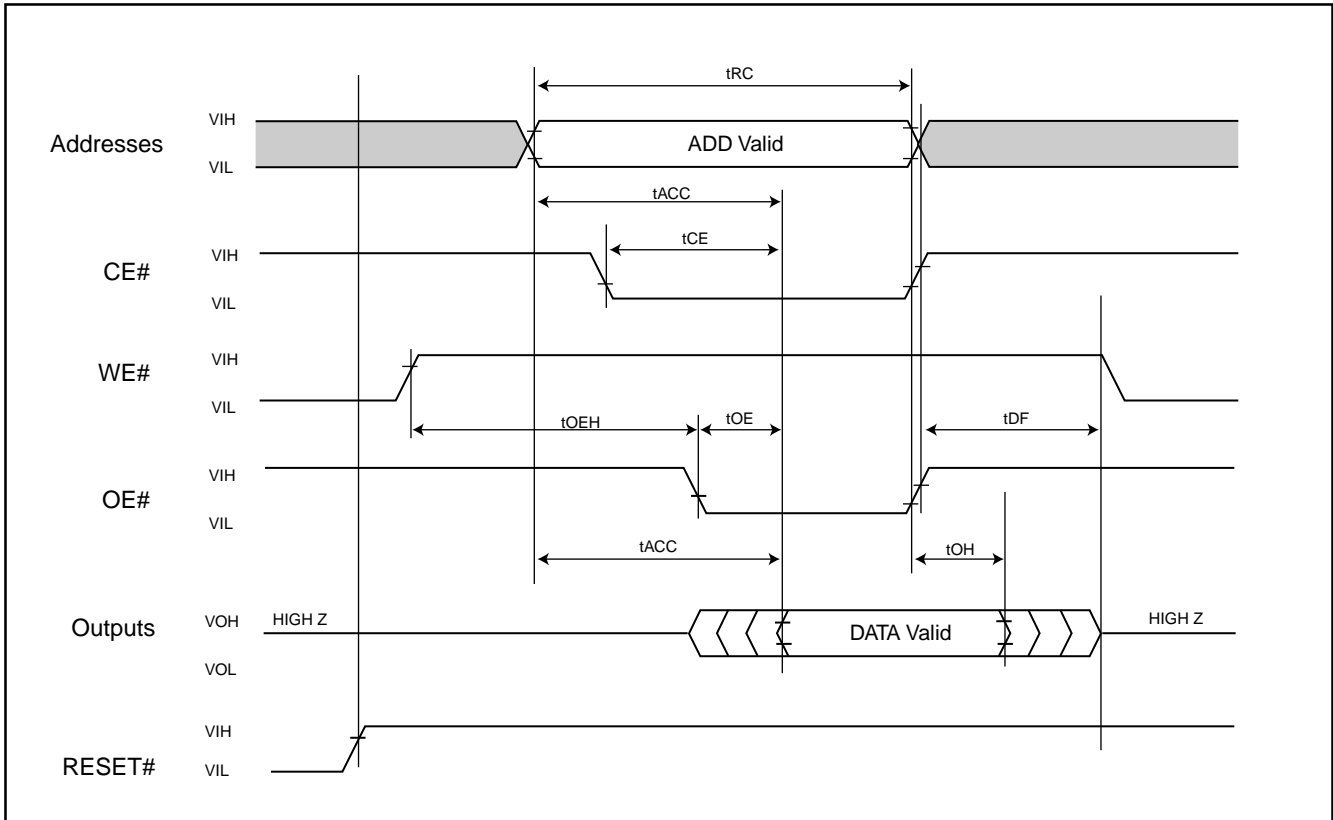

FIGURE 1. READ TIMING WAVEFORMS





AC CHARACTERISTICS TA = -40°C to 85°C, VCC = 2.7V~3.6V

TABLE 11. Erase/Program Operations

SYMBOL	PARAMETER	29LV800C-55R		29LV800C-70		29LV800C-90		UNIT
		MIN.	MAX.	MIN.	MAX.	MIN.	MAX.	
tWC	Write Cycle Time (Note 1)	55		70		90		ns
tAS	Address Setup Time	0		0		0		ns
tAH	Address Hold Time	45		45		45		ns
tDS	Data Setup Time	35		35		45		ns
tDH	Data Hold Time	0		0		0		ns
tOES	Output Enable Setup Time	0		0		0		ns
tGHWL	Read Recovery Time Before Write (OE# High to WE# Low)	0		0		0		ns
tCS	CE# Setup Time	0		0		0		ns
tCH	CE# Hold Time	0		0		0		ns
tWP	Write Pulse Width	35		35		35		ns
tWPH	Write Pulse Width High	30		30		30		ns
tWHWH1	Programming Operation (Note 2) (Byte/Word program time)	9/11(TYP.)		9/11(TYP.)		9/11(TYP.)		us
tWHWH2	Sector Erase Operation (Note 2)	0.7(TYP.)		0.7(TYP.)		0.7(TYP.)		sec
tVCS	VCC Setup Time (Note 1)	50		50		50		us
tRB	Recovery Time from RY/BY#	0		0		0		ns
tBUSY	Program/Erase Valid to RY/BY# Delay		90		90		90	ns
tWPP1	Write Pulse Width for Sector Protect (A9, OE# Control)	100ns	10us (Typ.)	100ns	10us (Typ.)	100ns	10us (Typ.)	
tWPP2	Write Pulse Width for Chip Unprotected (A9, OE# Control)	100ns	12ms (Typ.)	100ns	12ms (Typ.)	100ns	12ms (Typ.)	
tBAL	Sector Address Load Time		50		50		50	us

NOTES:

1. Not 100% tested.
2. See the "Erase and Programming Performance" section for more information.



AC CHARACTERISTICS TA = -40°C to 85°C, VCC = 2.7V~3.6V

TABLE 12. Alternate CE# Controlled Erase/Program Operations

SYMBOL	PARAMETER	29LV800C-55R		29LV800C-70		29LV800C-90		UNIT
		MIN.	MAX.	MIN.	MAX.	MIN.	MAX.	
tWC	Write Cycle Time (Note 1)	55		70		90		ns
tAS	Address Setup Time	0		0		0		ns
tAH	Address Hold Time	45		45		45		ns
tDS	Data Setup Time	35		35		45		ns
tDH	Data Hold Time	0		0		0		ns
tOES	Output Enable Setup Time	0		0		0		ns
tGHEL	Read Recovery Time Before Write	0		0		0		ns
tWS	WE# Setup Time	0		0		0		ns
tWH	WE# Hold Time	0		0		0		ns
tCP	CE# Pulse Width	35		35		35		ns
tCPH	CE# Pulse Width High	30		30		30		ns
tWHWH1	Programming Operation(note2)	Byte	9(Typ.)	9(Typ.)		9(Typ.)		us
		Word	11(Typ.)	11(Typ.)		11(Typ.)		us
tWHWH2	Sector Erase Operation (note2)	0.7(Typ.)		0.7(Typ.)		0.7(Typ.)		sec

NOTE:

1. Not 100% tested.
2. See the "Erase and Programming Performance" section for more information.

FIGURE 2. COMMAND WRITE TIMING WAVEFORM

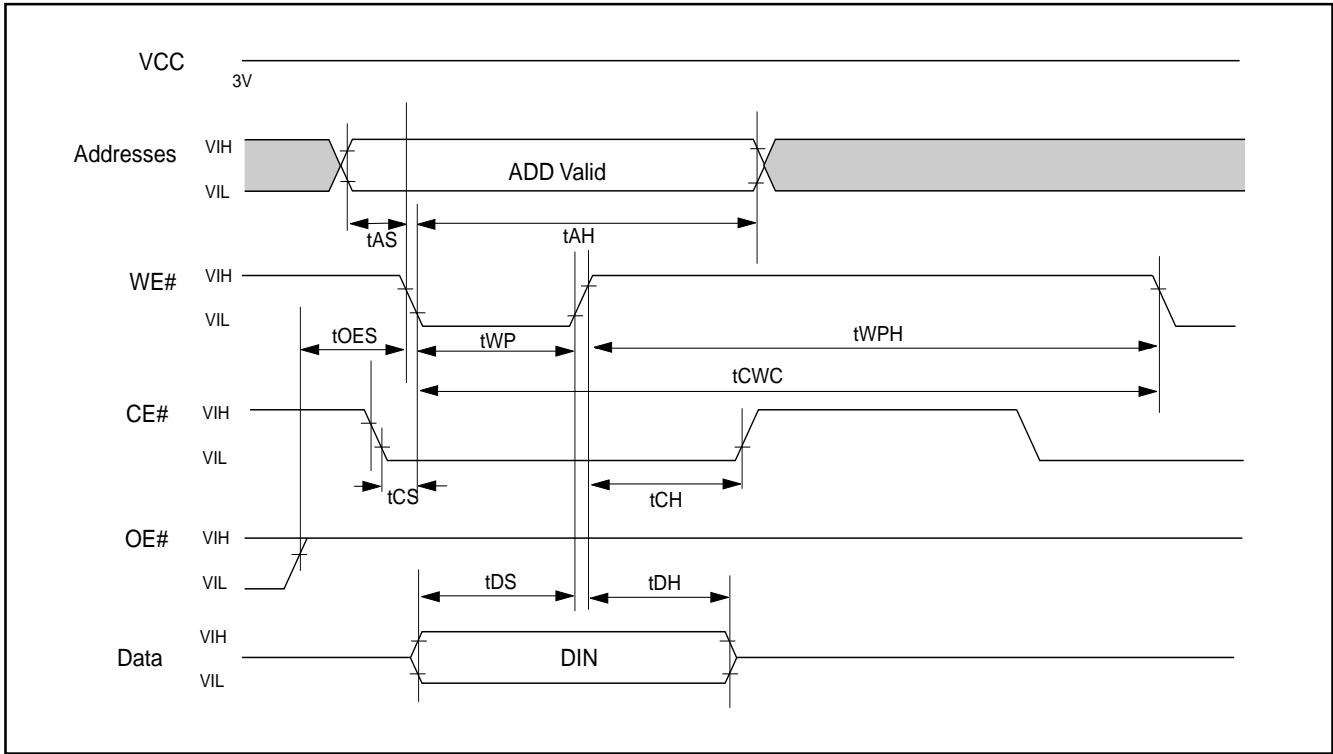

AUTOMATIC PROGRAMMING TIMING WAVEFORM

One byte data is programmed. Verify in fast algorithm and additional verification by external control are not required because these operations are executed automatically by internal control circuit. Programming completion can be verified by DATA# polling and toggle bit check-

ing after automatic programming starts. Device outputs DATA# during programming and DATA# after programming on Q7. (Q6 is for toggle bit; see toggle bit, DATA# polling, timing waveform)

FIGURE 3. AUTOMATIC PROGRAMMING TIMING WAVEFORM

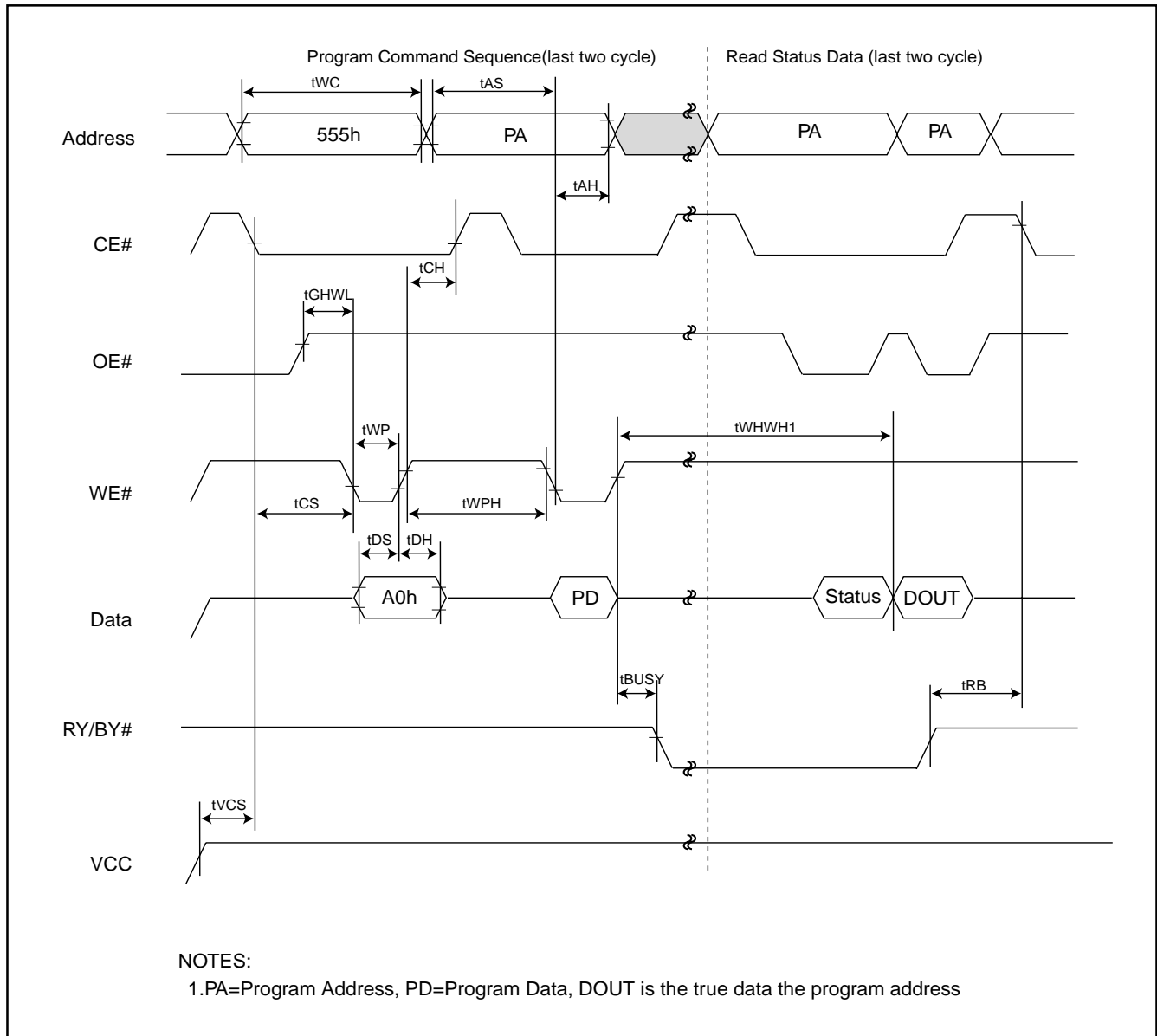

FIGURE 4. AUTOMATIC PROGRAMMING ALGORITHM FLOWCHART

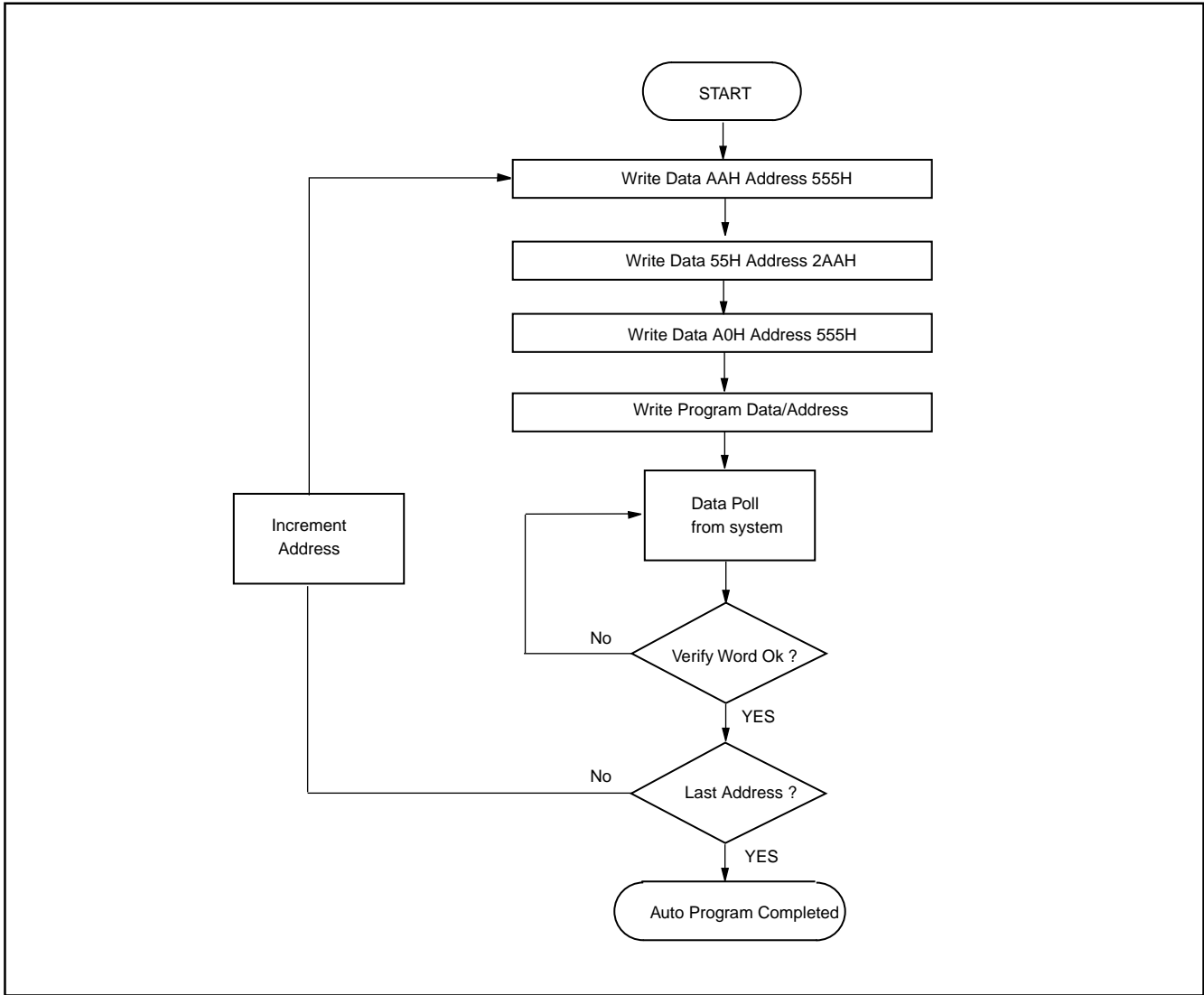
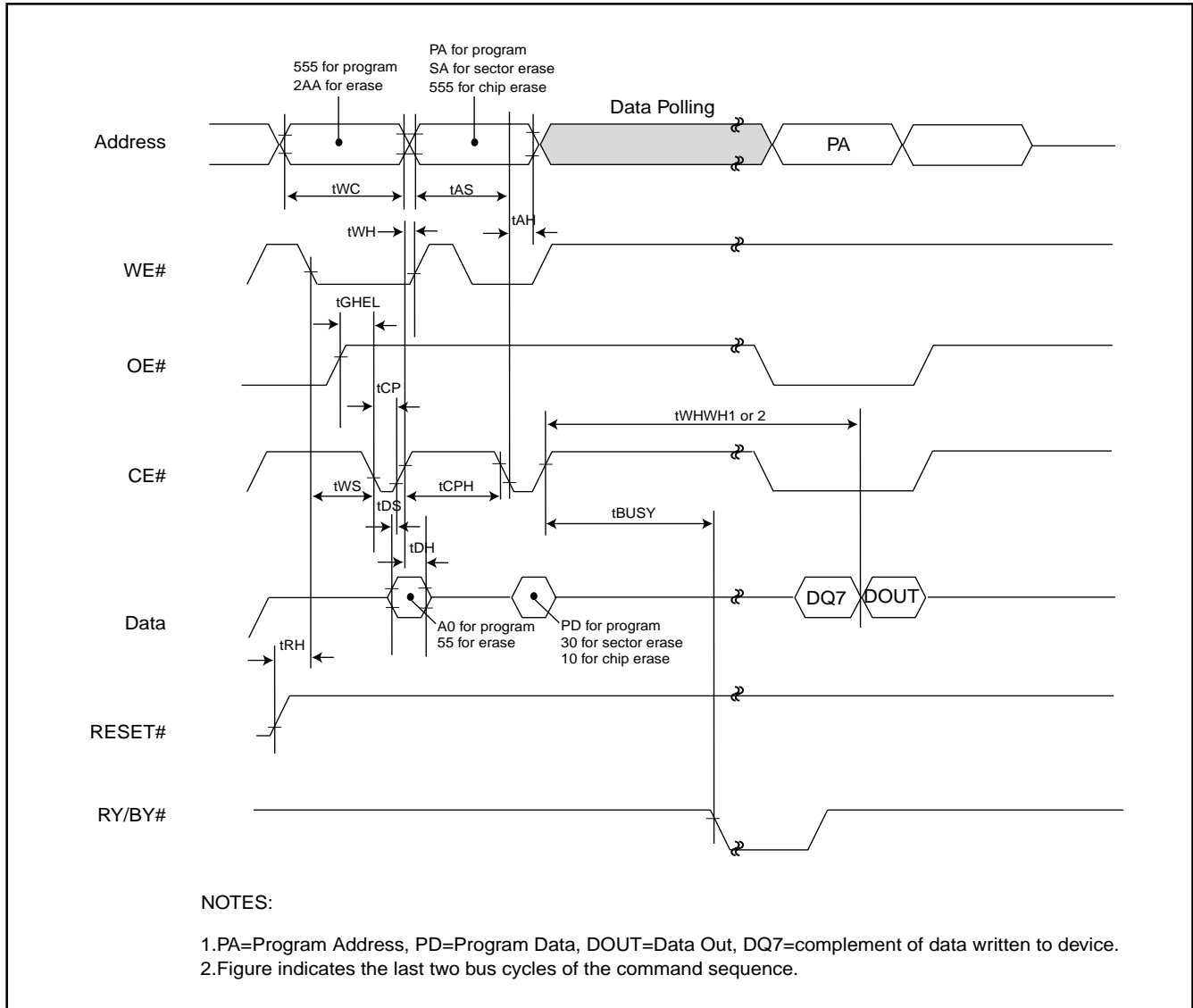

FIGURE 5. CE# CONTROLLED PROGRAMTIMING WAVEFORM



AUTOMATIC CHIP ERASE TIMING WAVEFORM

All data in chip are erased. External erase verification is not required because data is verified automatically by internal control circuit. Erasure completion can be verified by DATA# polling and toggle bit checking after auto-

matic erase starts. Device outputs 0 during erasure and 1 after erasure on Q7. (Q6 is for toggle bit; see toggle bit, DATA# polling, timing waveform)

FIGURE 6. AUTOMATIC CHIP ERASE TIMING WAVEFORM

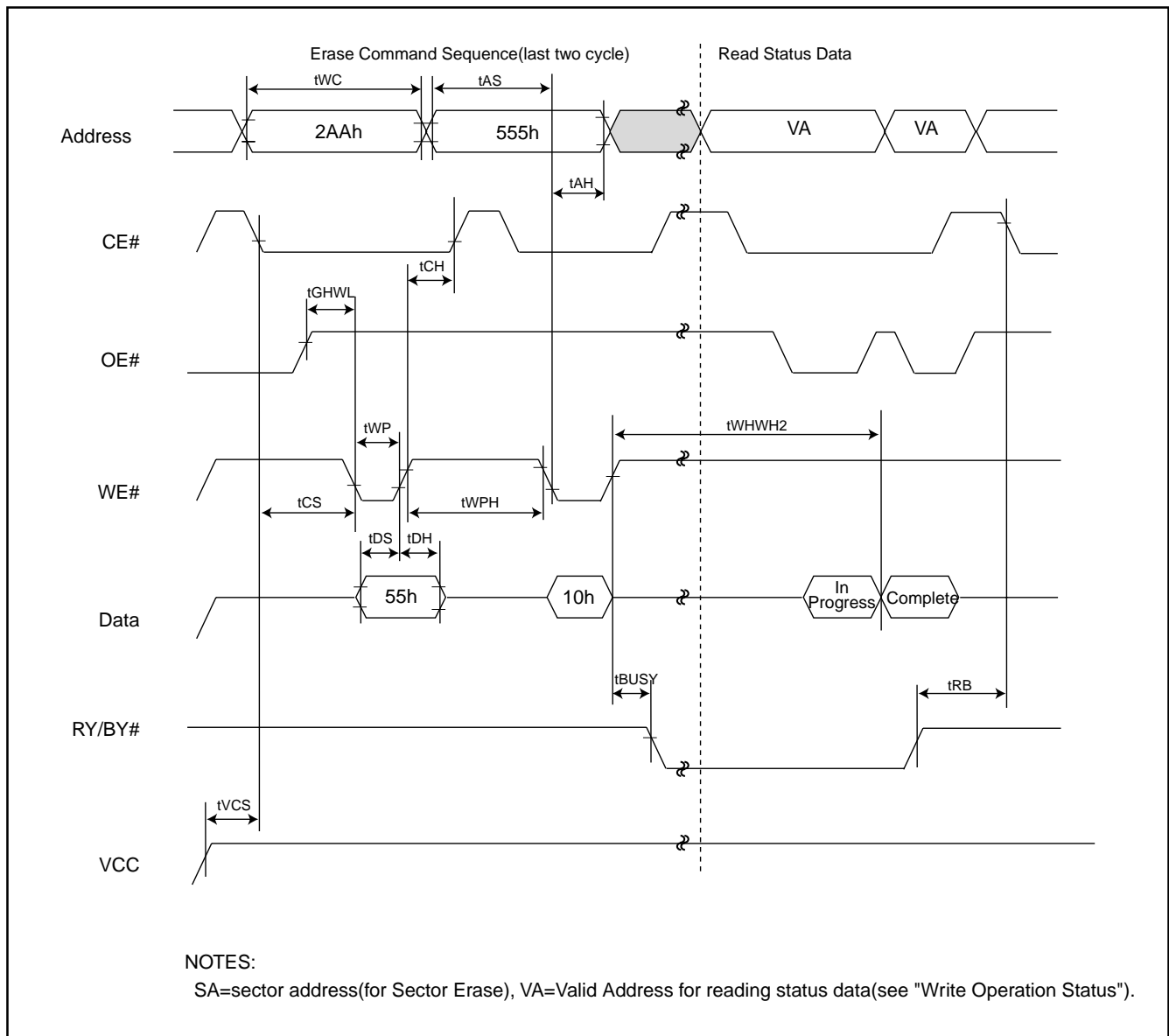
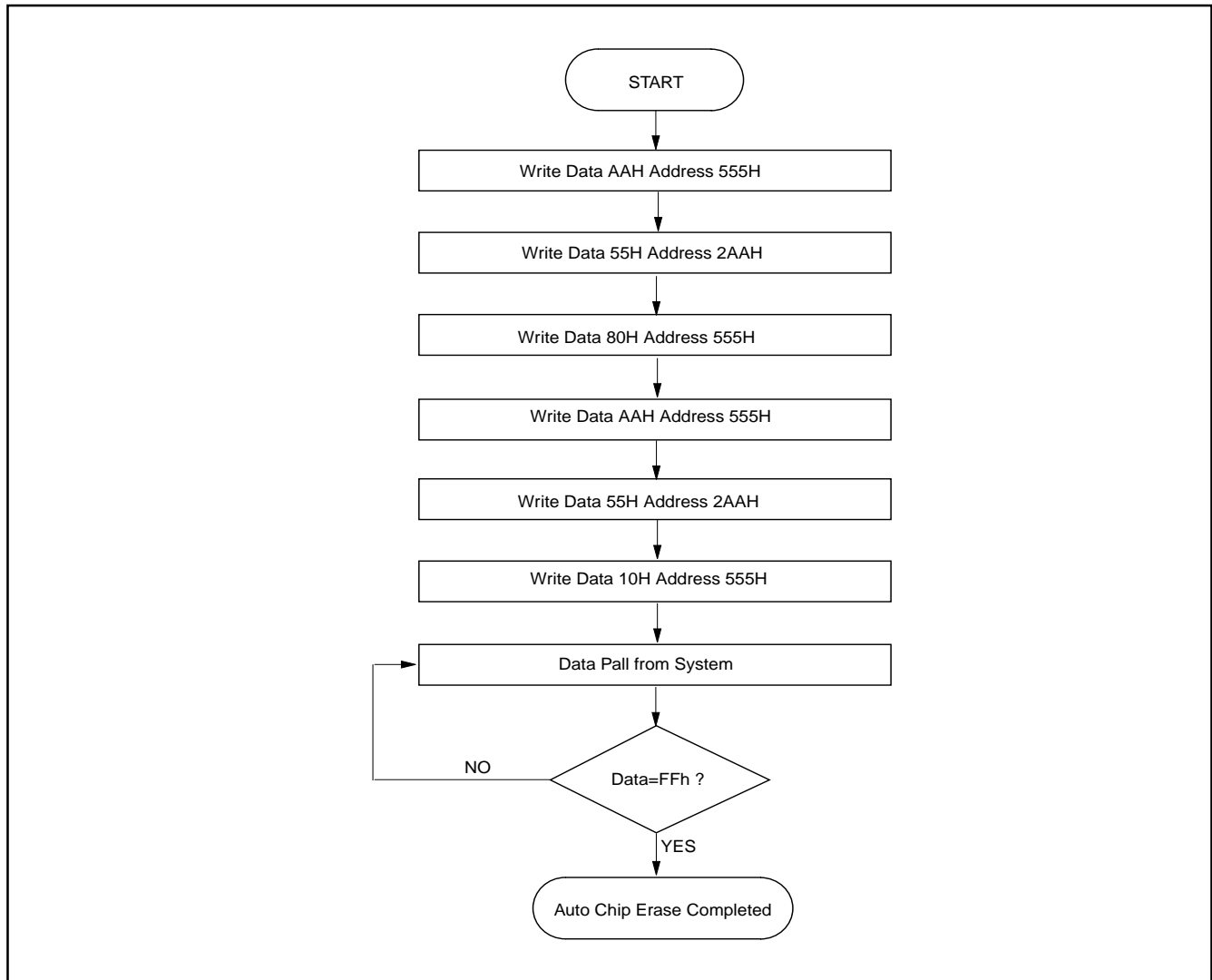

FIGURE 7. AUTOMATIC CHIP ERASE ALGORITHM FLOWCHART

AUTOMATIC SECTOR ERASE TIMING WAVEFORM

Sector indicated by A12 to A18 are erased. External erase verify is not required because data are verified automatically by internal control circuit. Erasure completion can be verified by DATA# polling and toggle bit check-

ing after automatic erase starts. Device outputs 0 during erasure and 1 after erasure on Q7. (Q6 is for toggle bit; see toggle bit, DATA# polling, timing waveform)

FIGURE 8. AUTOMATIC SECTOR ERASE TIMING WAVEFORM

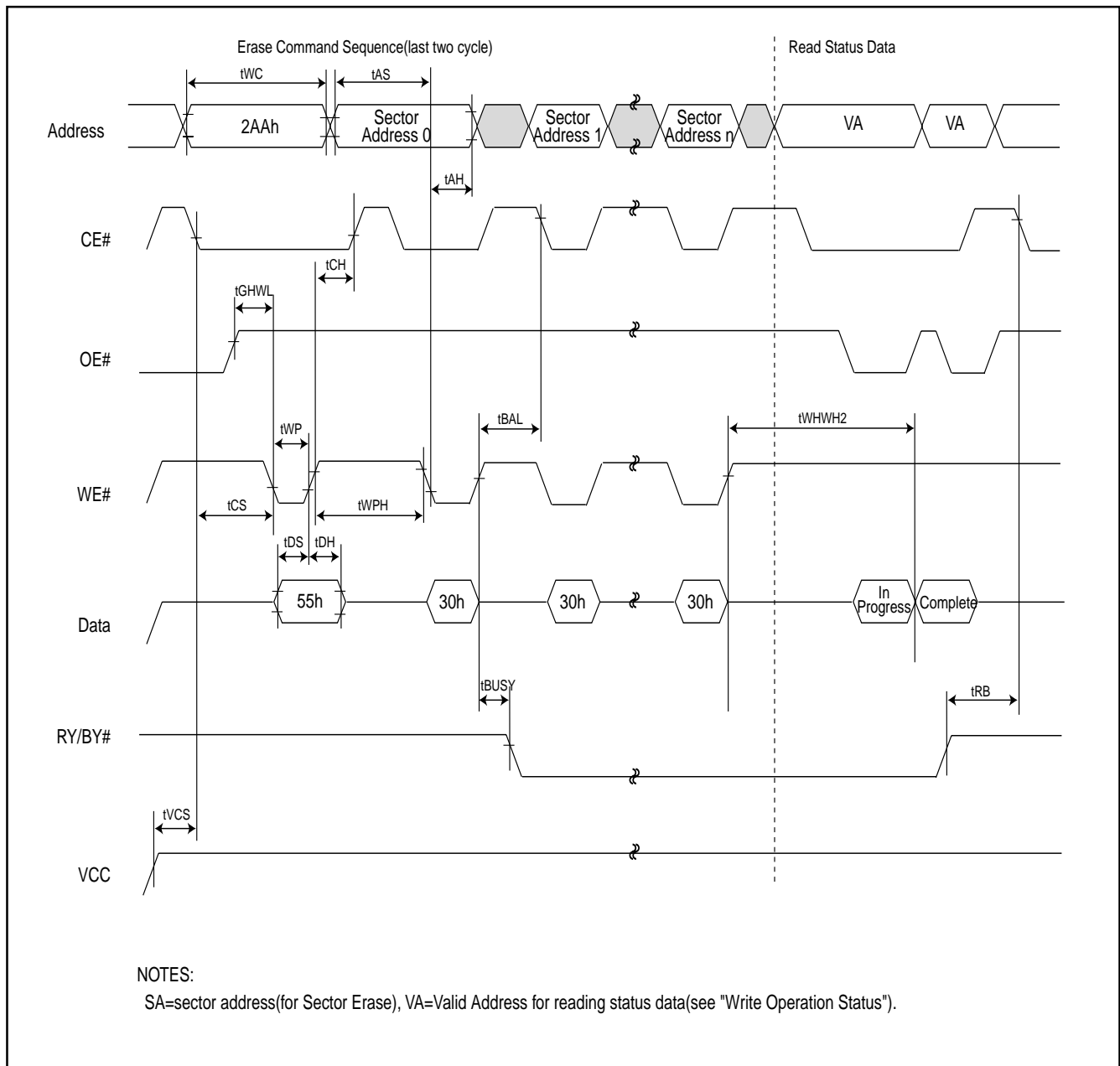

FIGURE 9. AUTOMATIC SECTOR ERASE ALGORITHM FLOWCHART

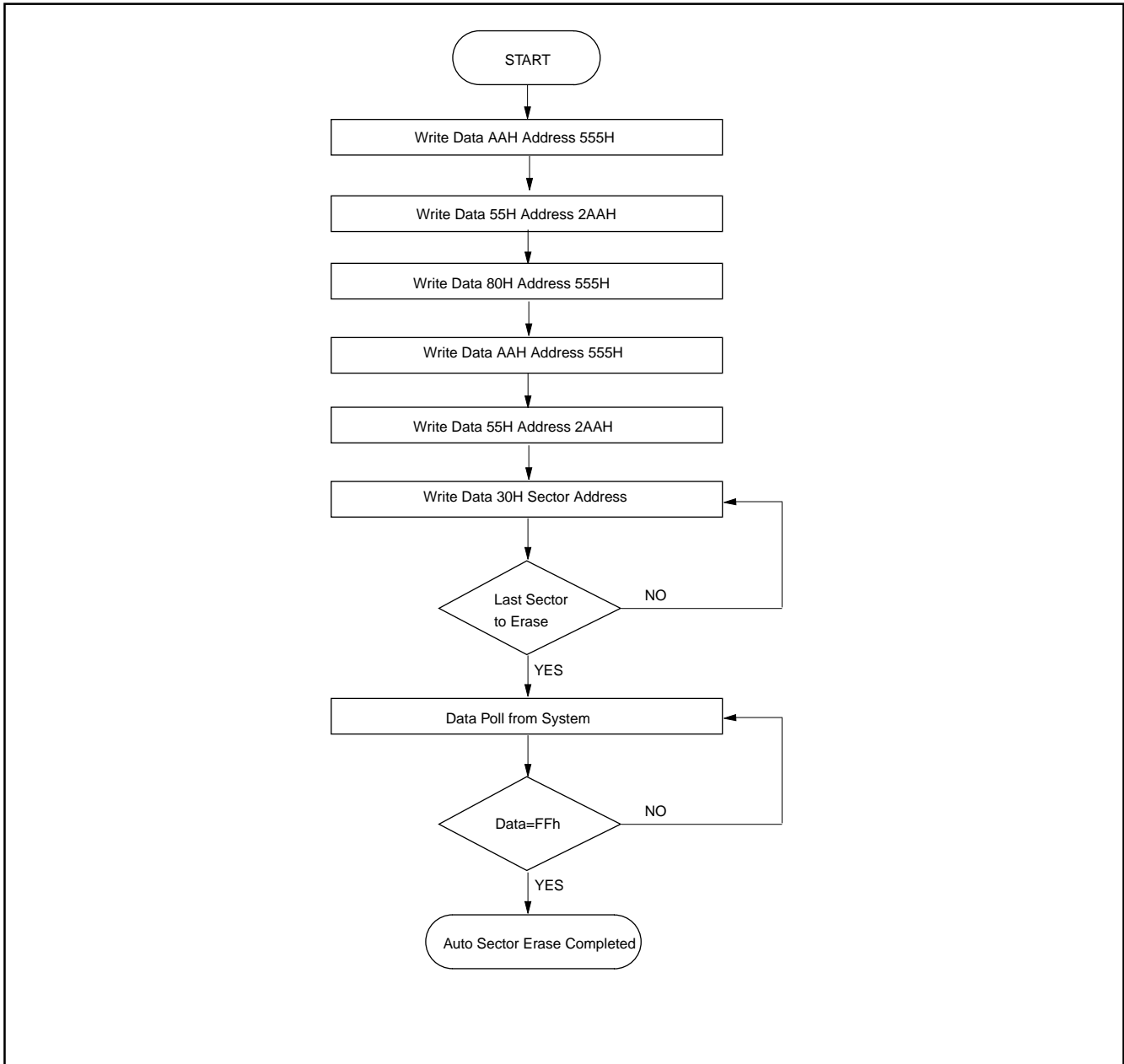
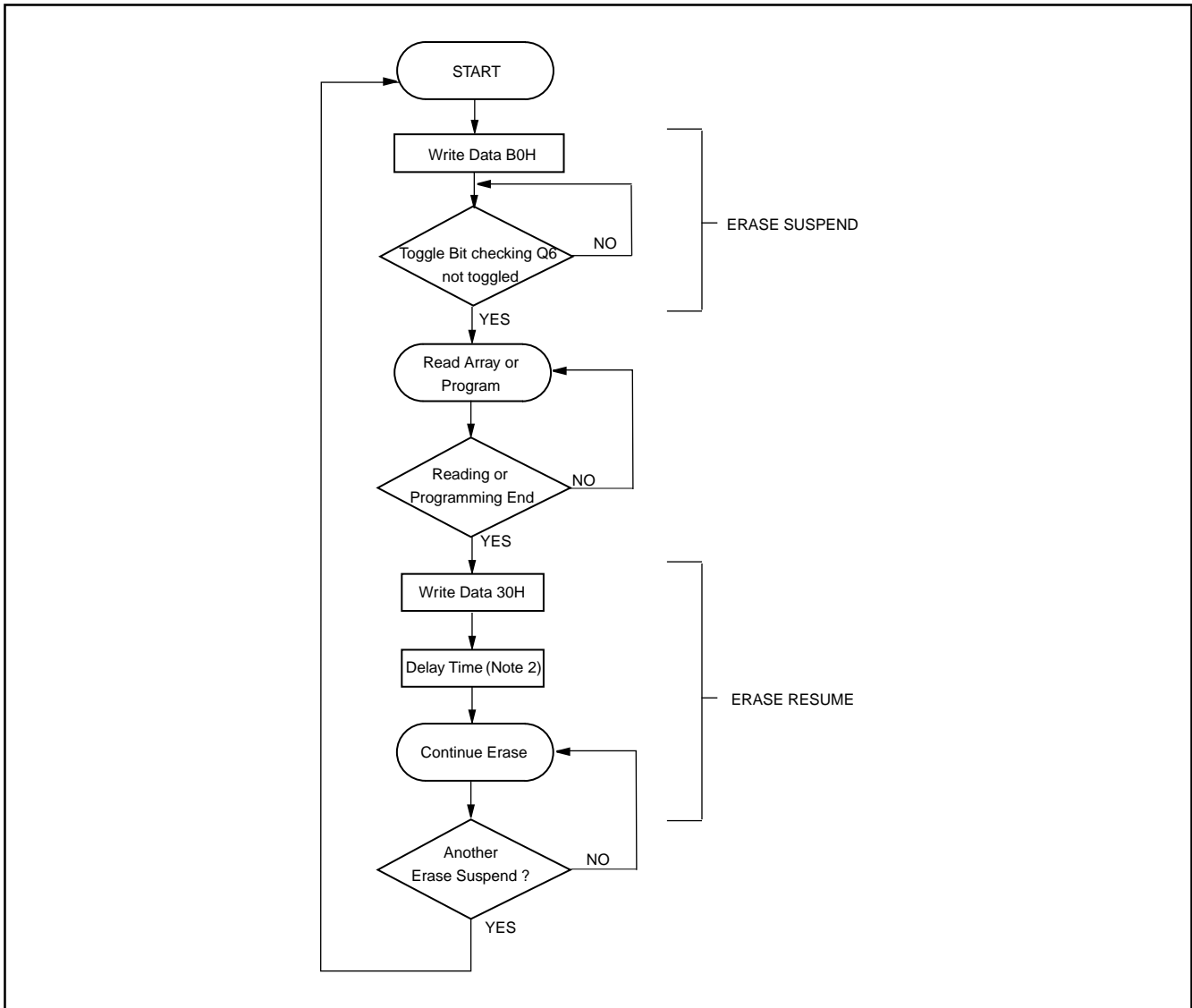

FIGURE 10. ERASE SUSPEND/ERASE RESUME FLOWCHART



Note:

1. If the system implements an endless erase suspend/resume loop, or the number of erase suspend/resume is exceeded 1024 times, then the delay time must be put into consideration.
2. Delay timing: 1.5ms for MX29LV800C T/B.

FIGURE 11. IN-SYSTEM SECTOR PROTECT/UNPROTECTED TIMING WAVEFORM (RESET# Control)

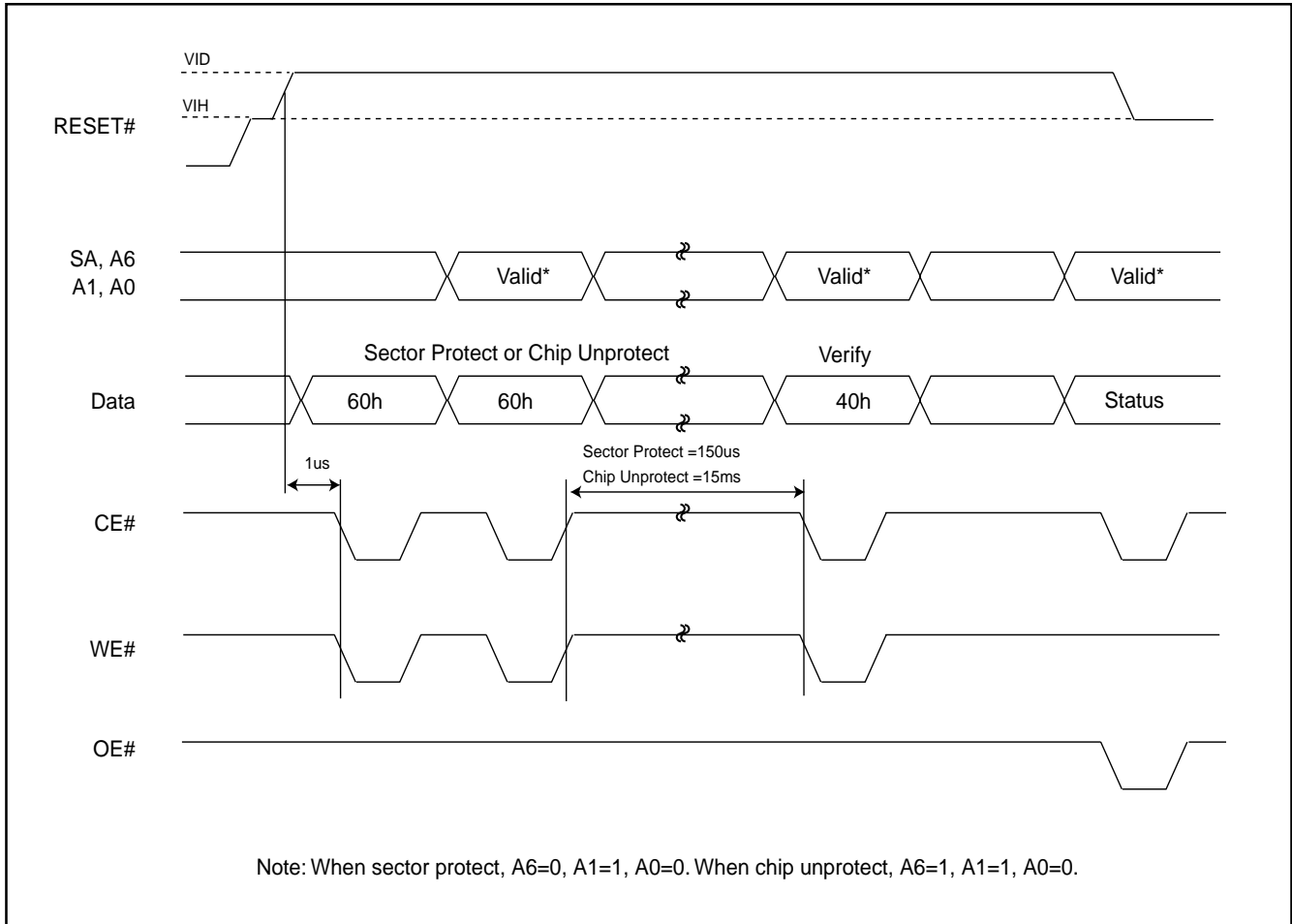

FIGURE 12. SECTOR PROTECT TIMING WAVEFORM (A9, OE# Control)

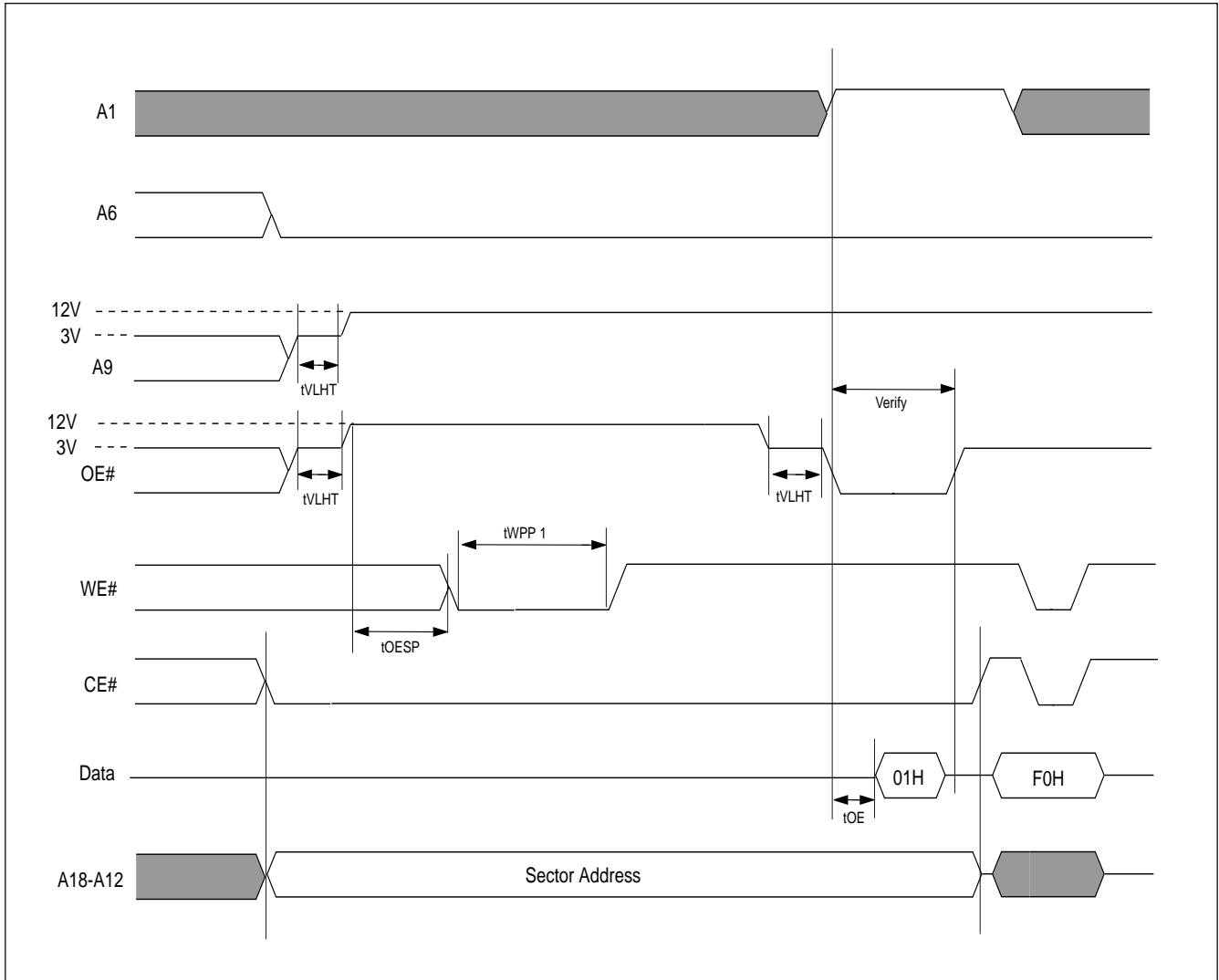

FIGURE 13. SECTOR PROTECTION ALGORITHM (A9, OE# Control)

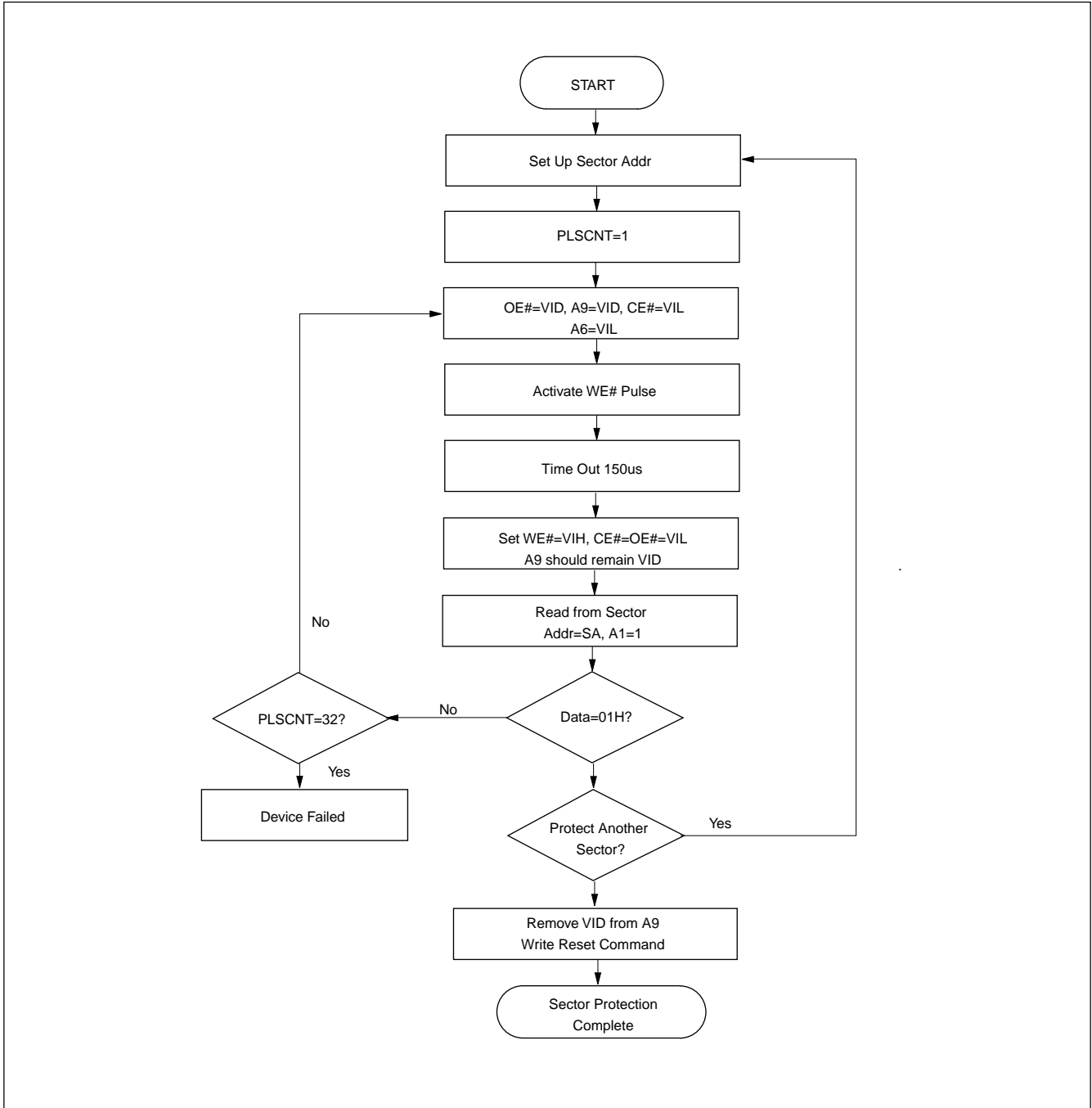

FIGURE 14. IN-SYSTEM SECTOR PROTECTION ALGORITHM WITH RESET#=VID

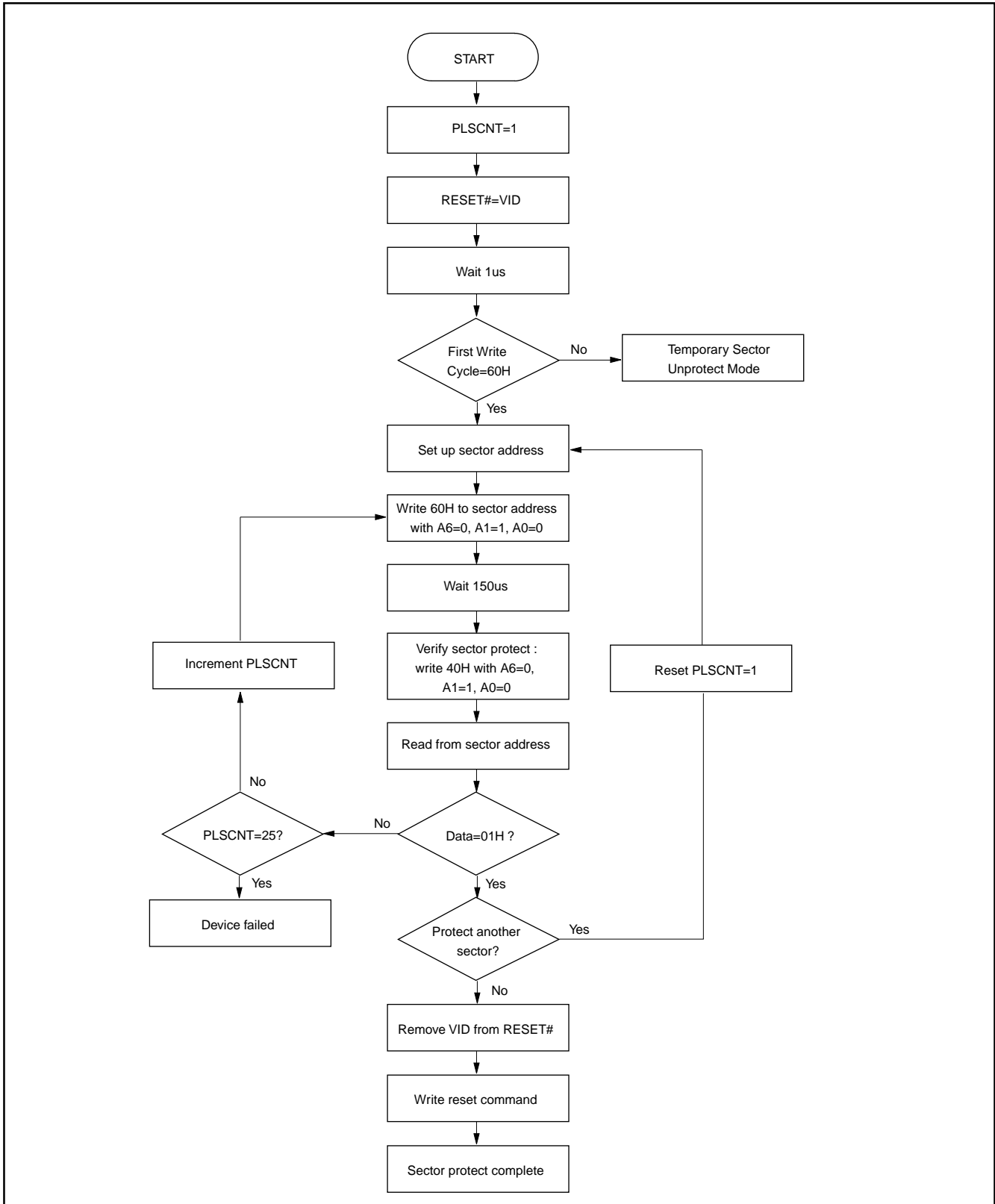

FIGURE 15. IN-SYSTEM CHIP UNPROTECTION ALGORITHM WITH RESET# = VID

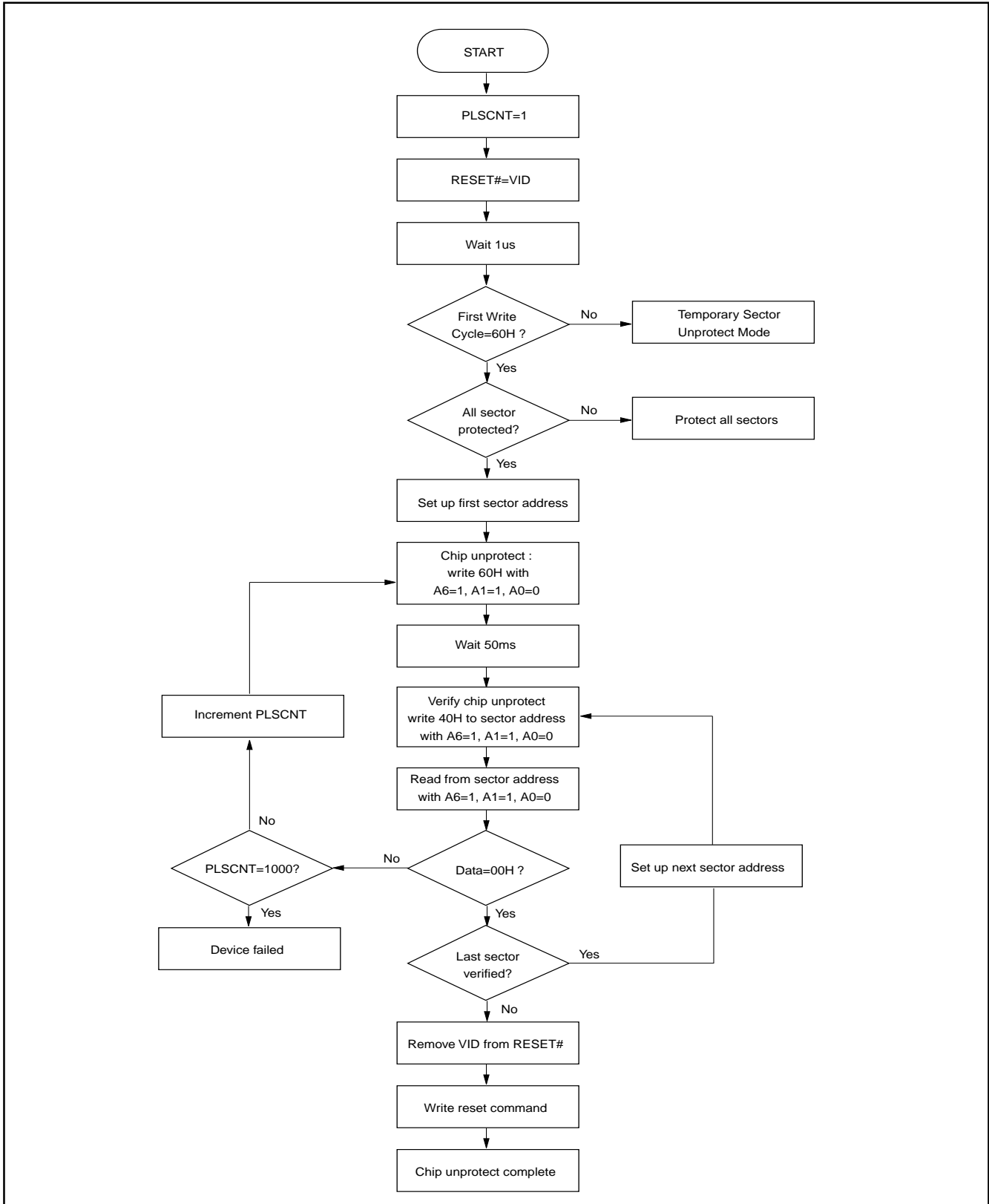
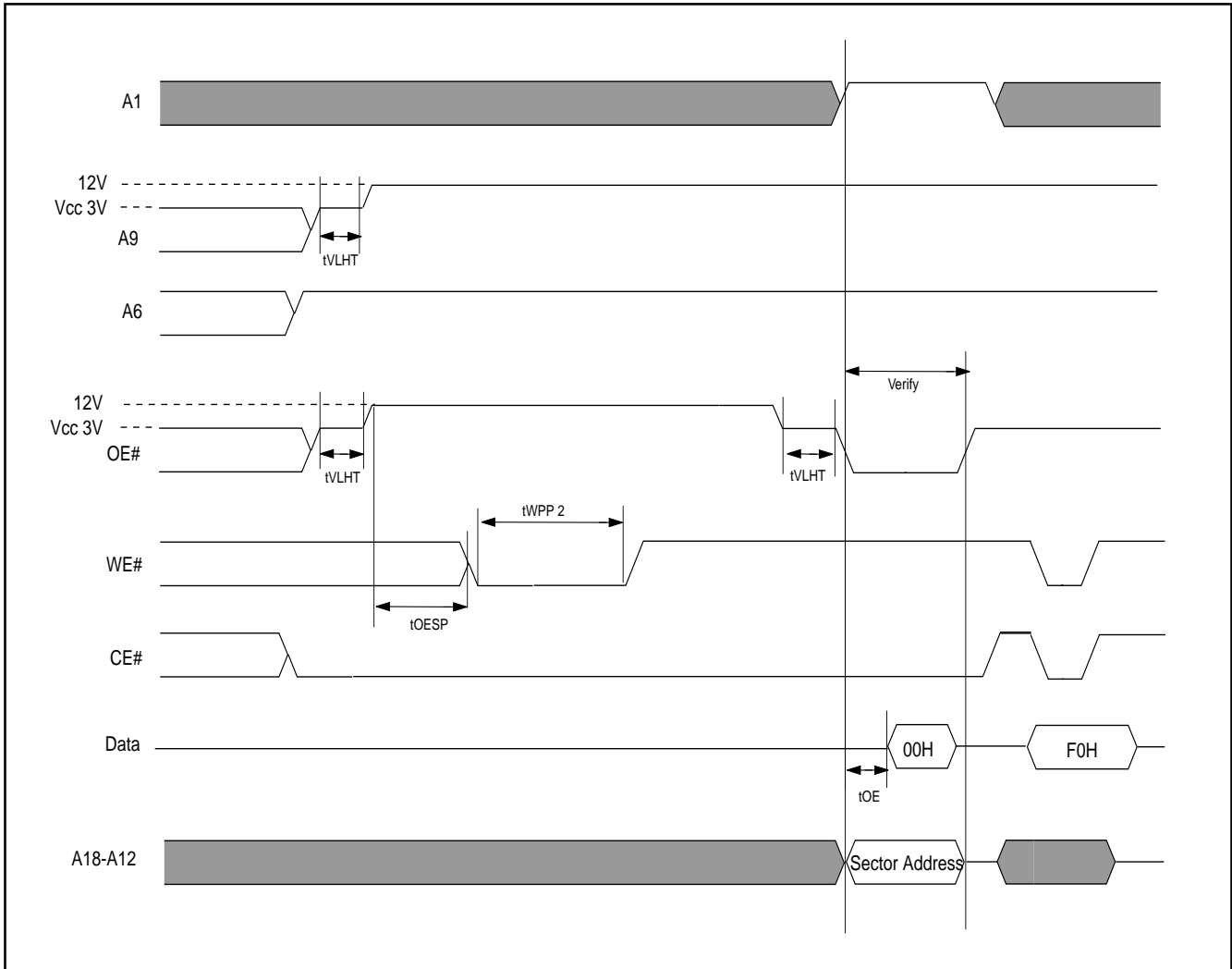
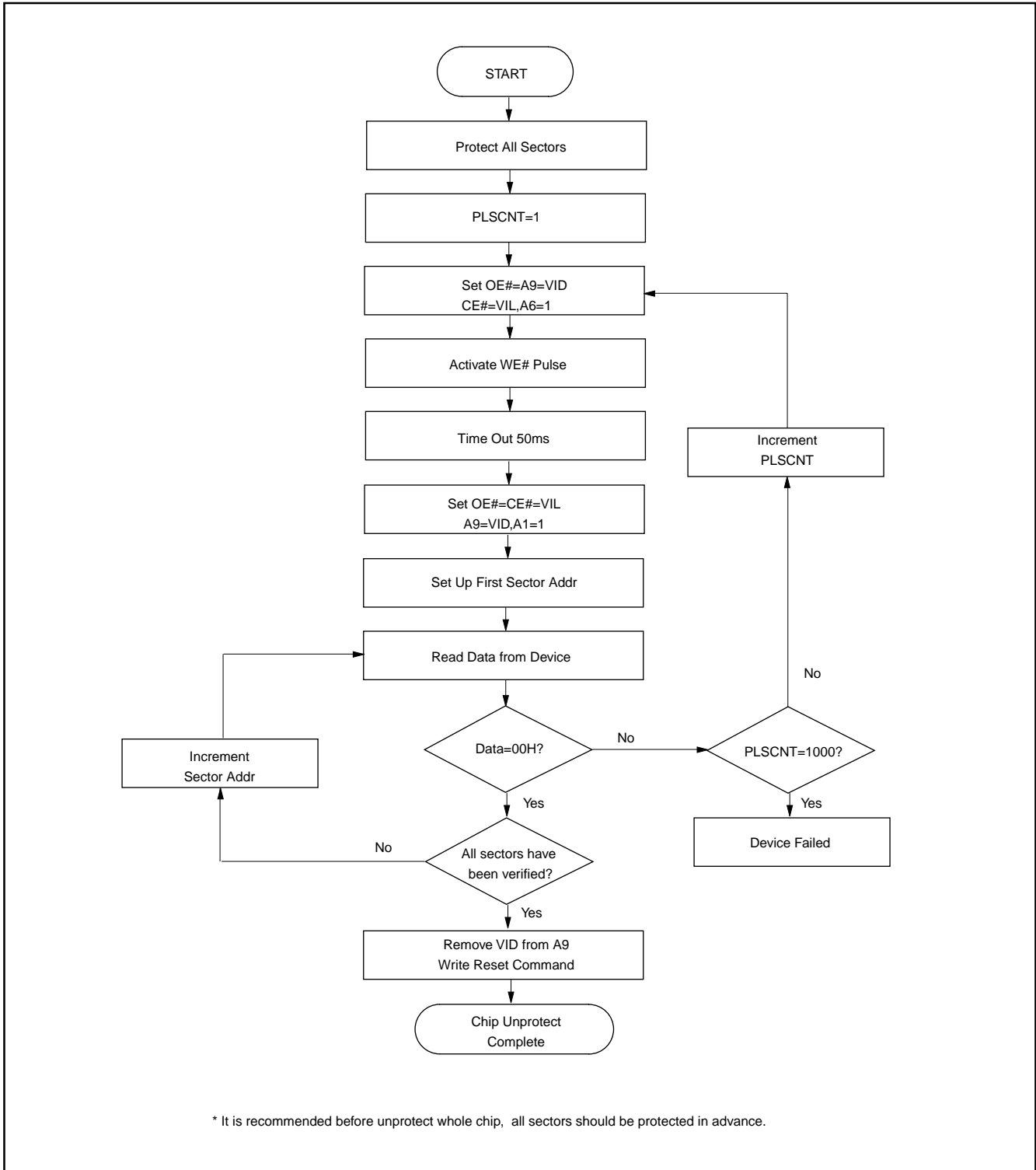

FIGURE 16. TIMING WAVEFORM FOR CHIP UNPROTECTION (A9, OE# Control)



- Notes:
- t_{VLHT} (Voltage transition time)=4us min.
 - t_{WPP1} (Write pulse width for sector protect)=100ns min, 10us(Typ.)
 - t_{WPP2} (Write pulse width for chip unprotected)=100ns min, 12ms(Typ.)
 - t_{OESP} (OE# setup time to WE# active)=4us min.

FIGURE 17. CHIP UNPROTECTION ALGORITHM (A9, OE# Control)



WRITE OPERATION STATUS

FIGURE 18. DATA# POLLING ALGORITHM

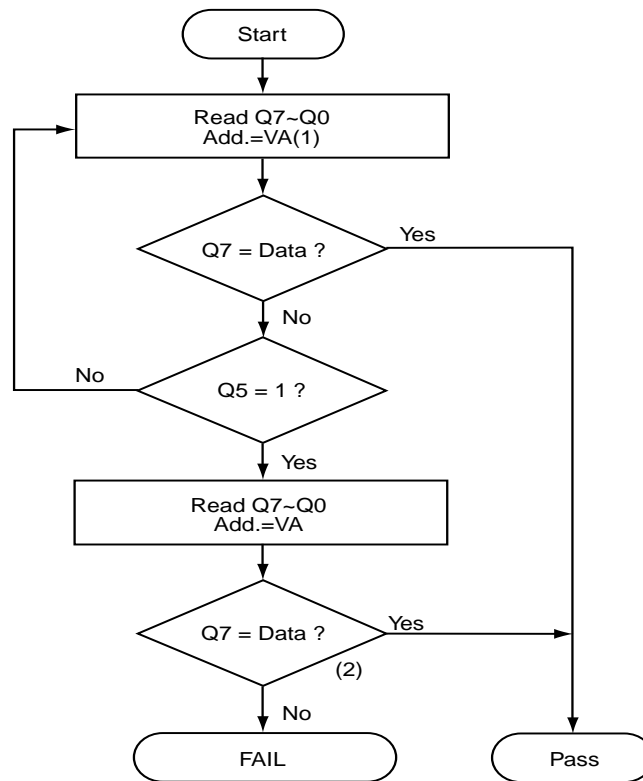

NOTE : 1.VA=Valid address for programming

2.Q7 should be re-checked even Q5="1" because Q7 may change simultaneously with Q5.

FIGURE 19. TOGGLE BIT ALGORITHM

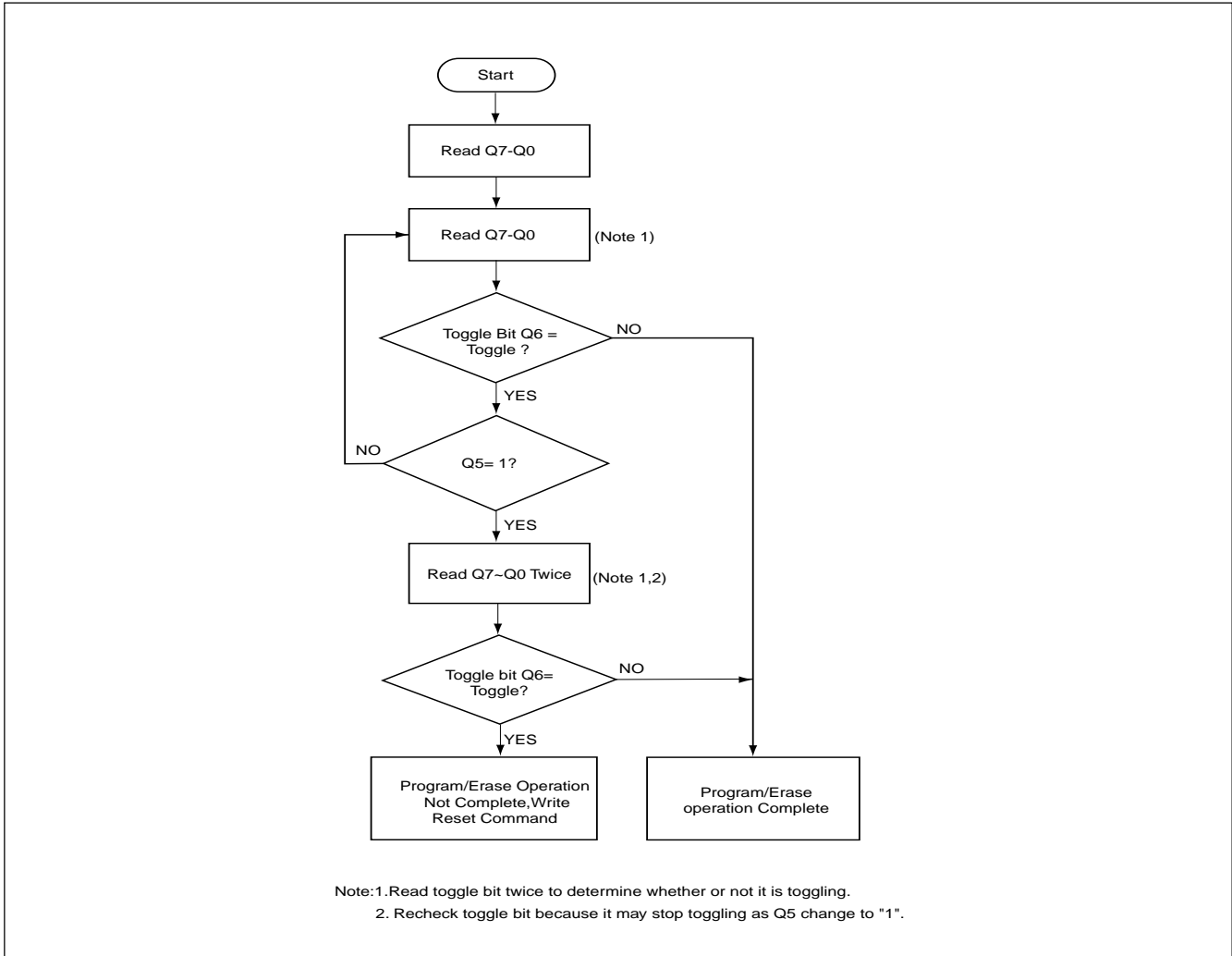
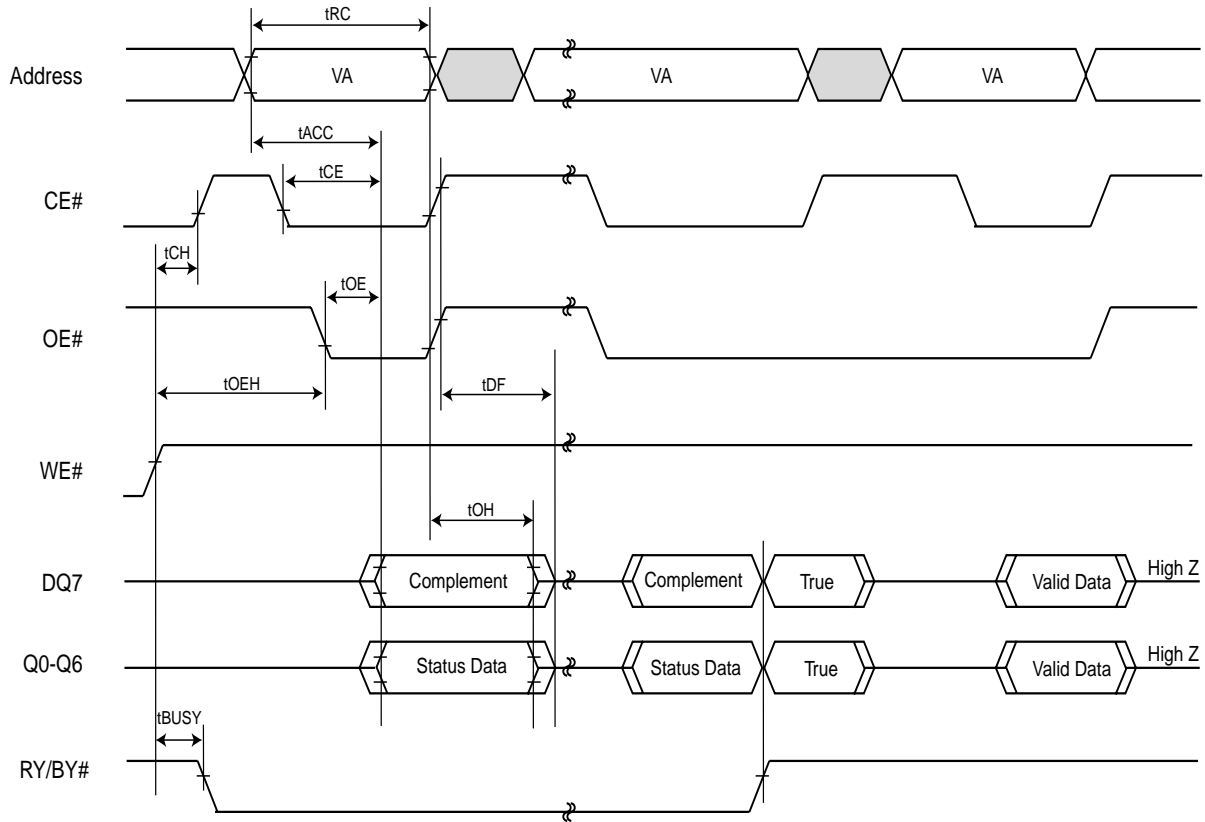

FIGURE 20. DATA# Polling Timings (During Automatic Algorithms)



NOTES:

1. VA=Valid address. Figure shows are first status cycle after command sequence, last status read cycle, and array data read cycle.
2. CE# must be toggled when DATA# polling.

FIGURE 21. Toggle Bit Timings (During Automatic Algorithms)

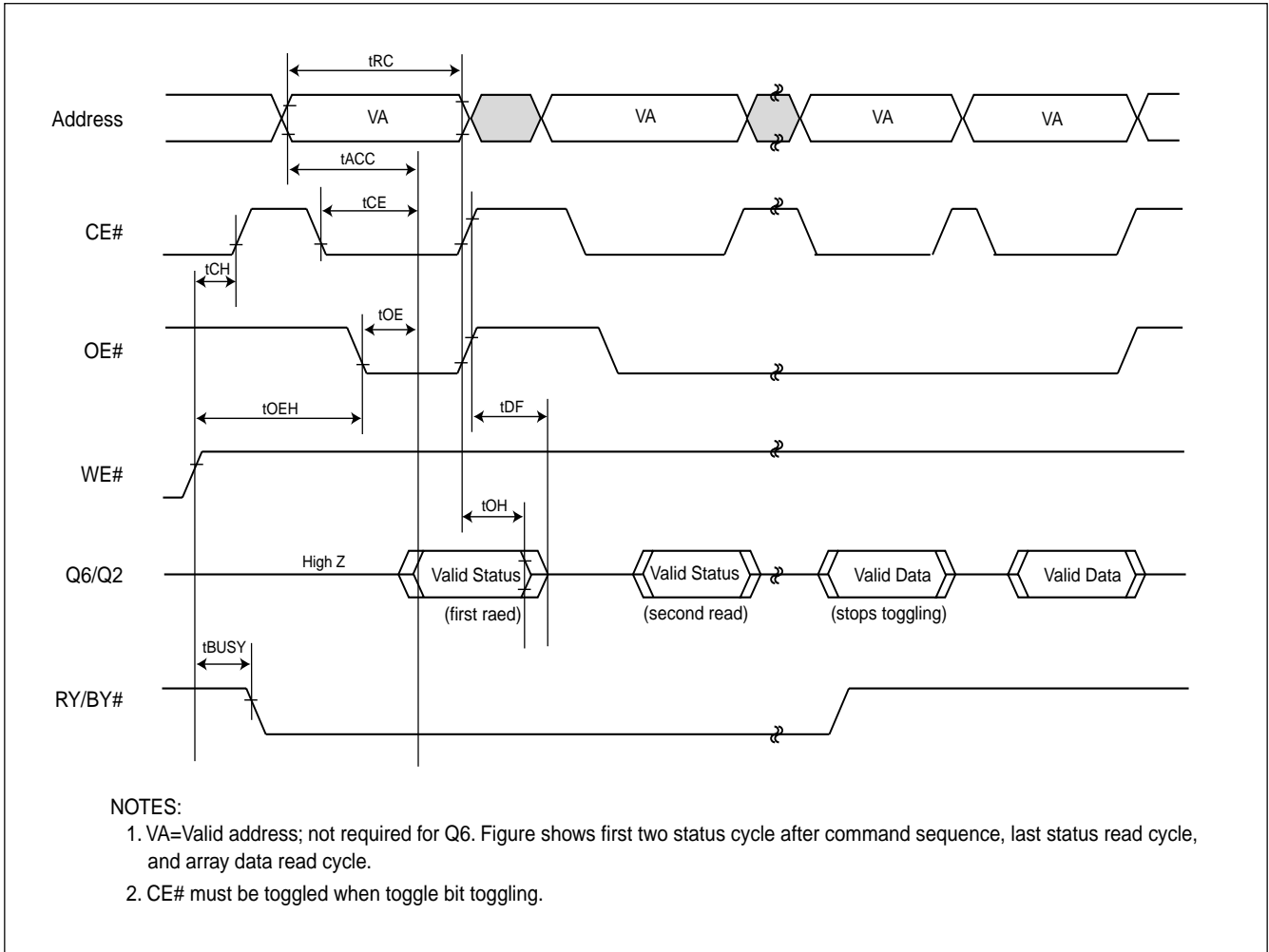
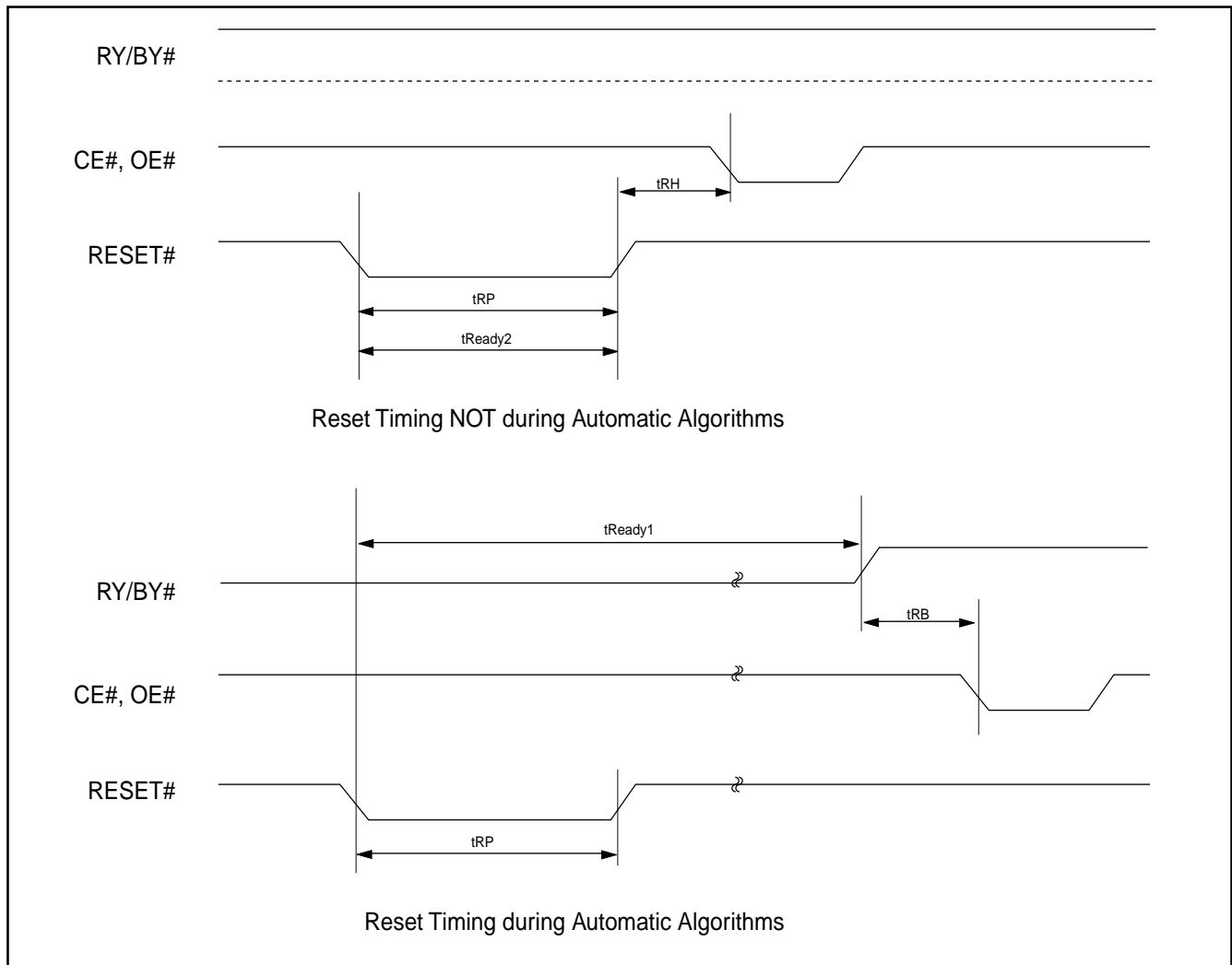

TABLE 13. AC CHARACTERISTICS

Parameter Std	Description	Test Setup	All Speed Options	Unit
tREADY1	RESET# PIN Low (During Automatic Algorithms) to Read or Write (See Note)	MAX	20	us
tREADY2	RESET# PIN Low (NOT During Automatic Algorithms) to Read or Write (See Note)	MAX	500	ns
tRP	RESET# Pulse Width (During Automatic Algorithms)	MIN	500	ns
tRH	RESET# High Time Before Read (See Note)	MIN	50	ns
tRB	RY/BY# Recovery Time (to CE#, OE# go low)	MIN	0	ns

Note: Not 100% tested

FIGURE 22. RESET# TIMING WAVEFORM



AC CHARACTERISTICS

TABLE 14. WORD/BYTE CONFIGURATION (BYTE#)

Parameter		Description		Speed Options			Unit	JEDEC
Std				-55	-70	-90		
	tELFL/tELFH	CE# to BYTE# Switching Low or High	Max	5				ns
	tFLQZ	BYTE# Switching Low to Output HIGH Z	Max	25	25	30		ns
	tFHQV	BYTE# Switching High to Output Active	Min	55	70	90		ns

FIGURE 23. BYTE# TIMING WAVEFORM FOR READ OPERATIONS (BYTE# switching from byte mode to word mode)

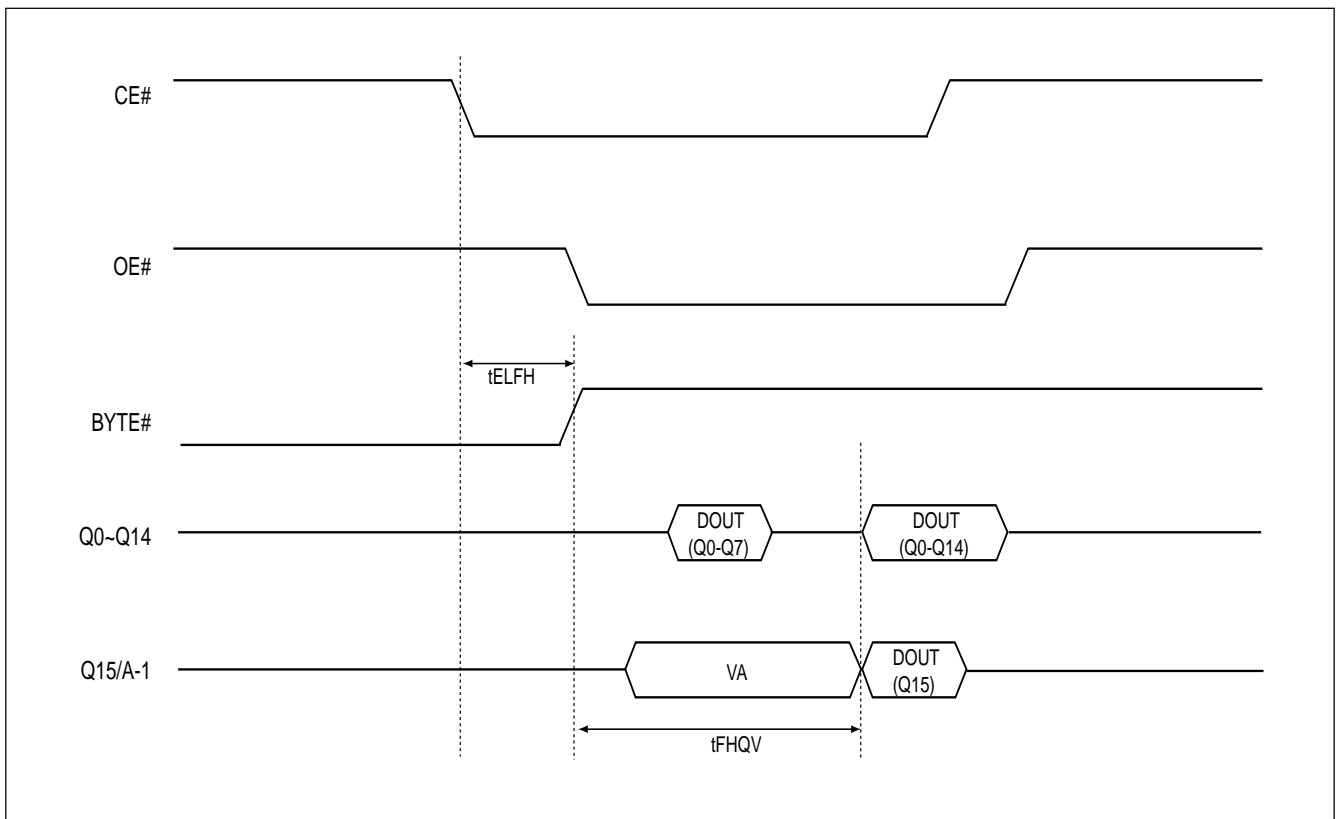

FIGURE 24. BYTE# TIMING WAVEFORM FOR READ OPERATIONS (BYTE# switching from word mode to byte mode)

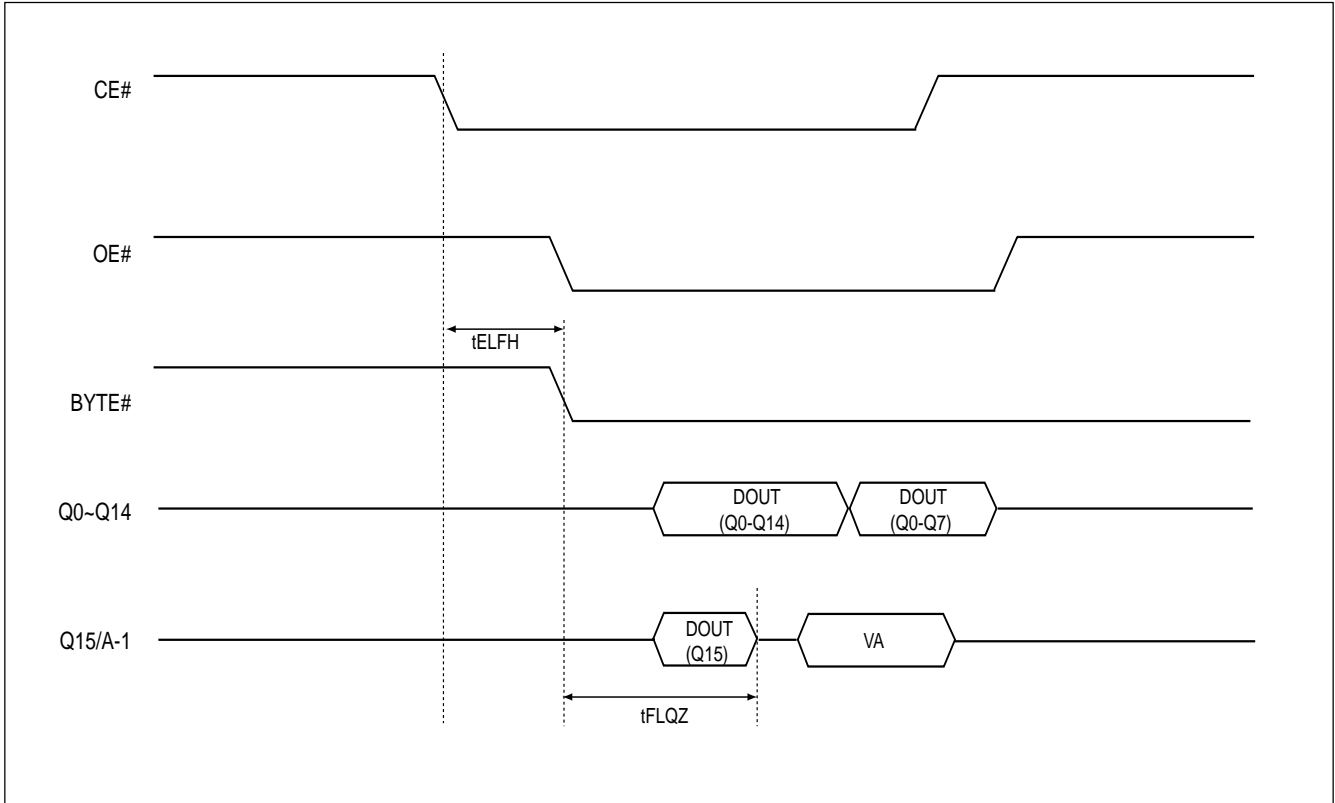

FIGURE 25. BYTE# TIMING WAVEFORM FOR PROGRAM OPERATIONS

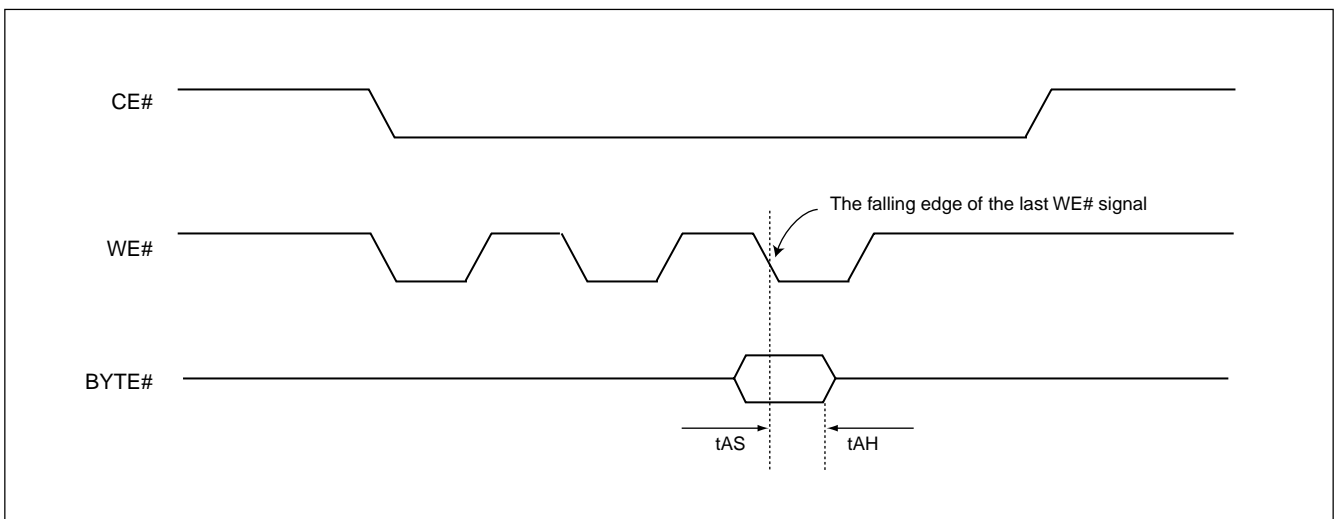

TABLE 15. TEMPORARY SECTOR UNPROTECTED

Parameter Std.	Description	Test Setup	All Speed Options	Unit
tVIDR	VID Rise and Fall Time (See Note)	Min	500	ns
tRSP	RESET# Setup Time for Temporary Sector Unprotected	Min	4	us

Note:
Not 100% tested

FIGURE 26. TEMPORARY SECTOR UNPROTECTED TIMING DIAGRAM

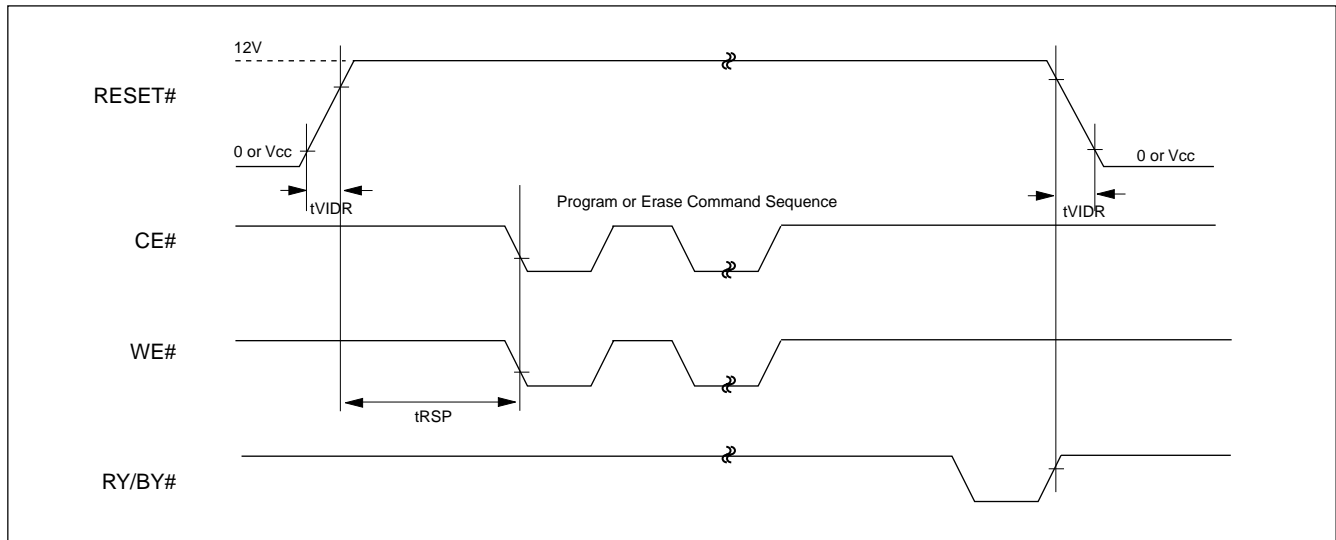

FIGURE 27. Q6 vs Q2 for Erase and Erase Suspend Operations

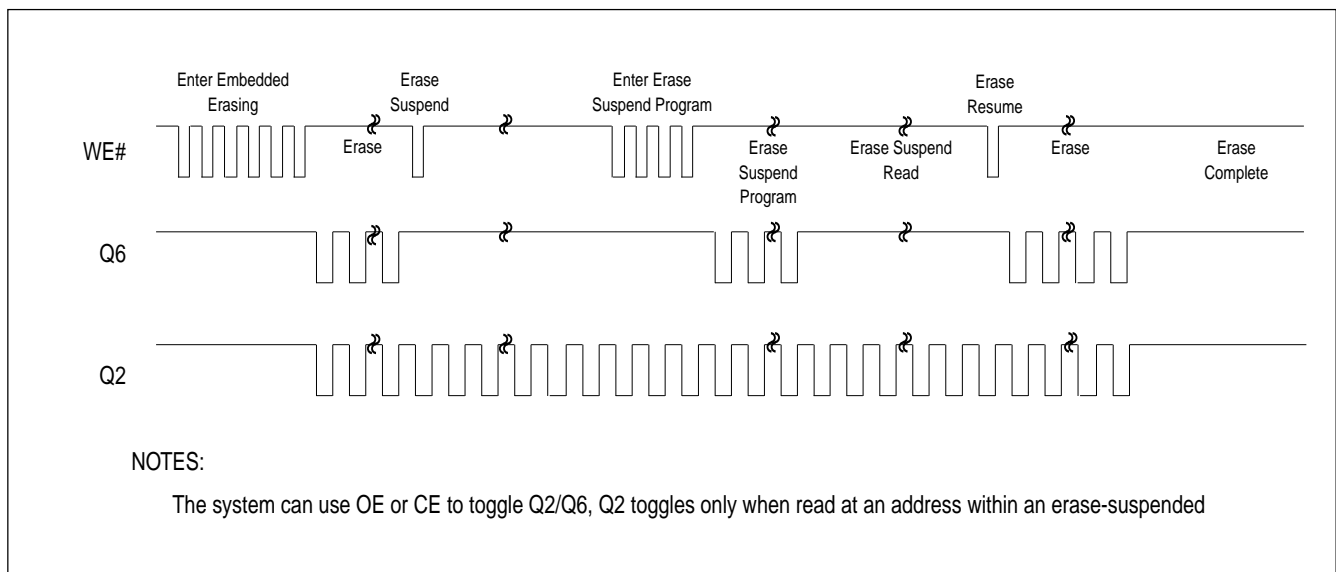

FIGURE 28. TEMPORARY SECTOR UNPROTECTED ALGORITHM

FIGURE 29. ID CODE READTIMING WAVEFORM



RECOMMENDED OPERATING CONDITIONS

At Device Power-Up

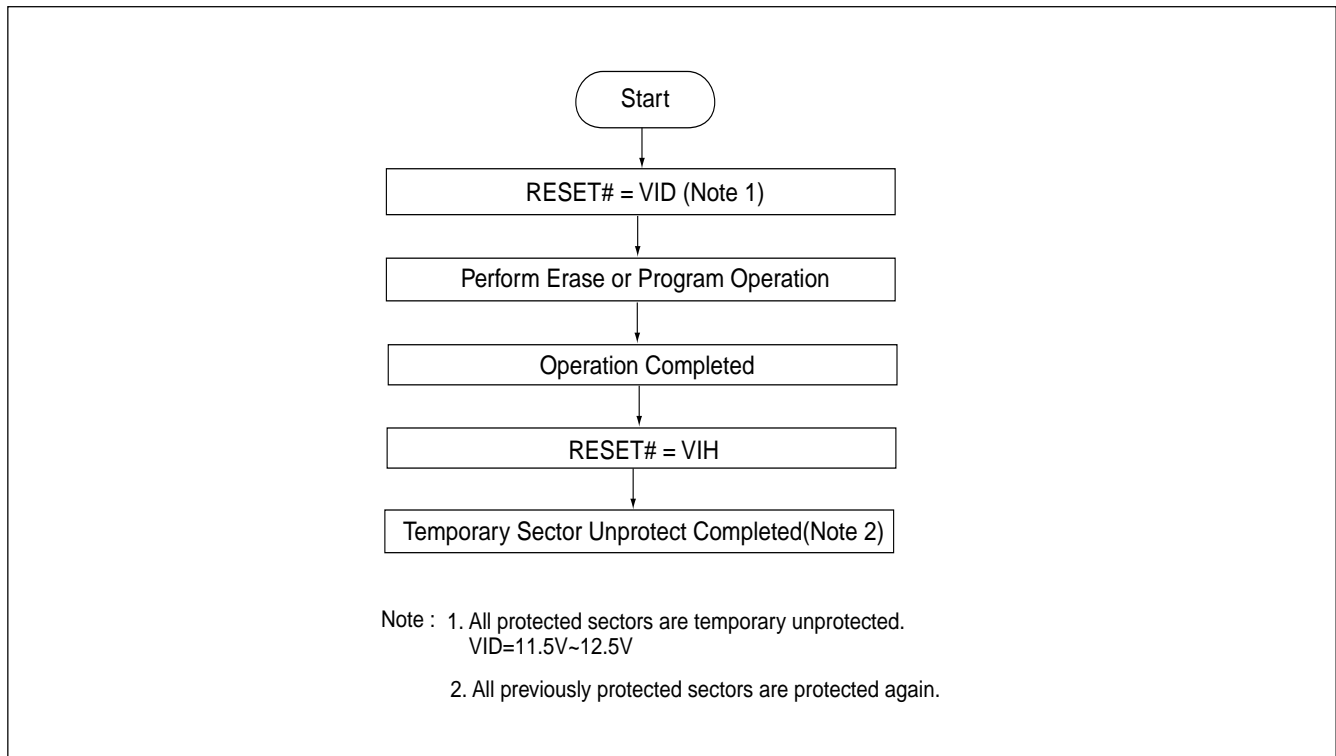
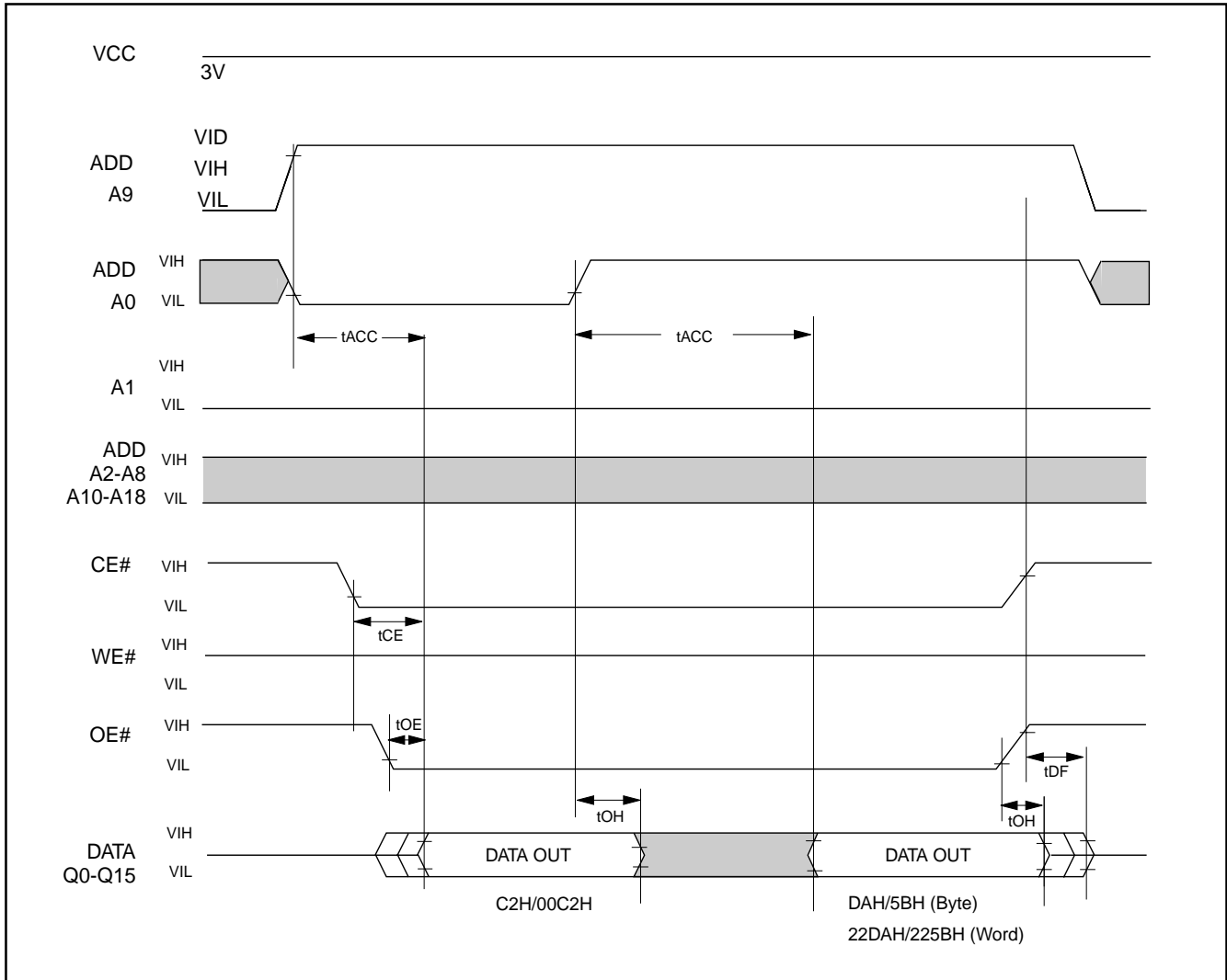
AC timing illustrated in Figure A is recommended for the supply voltages and the control signals at device power-up. If the timing in the figure is ignored, the device may not operate correctly.

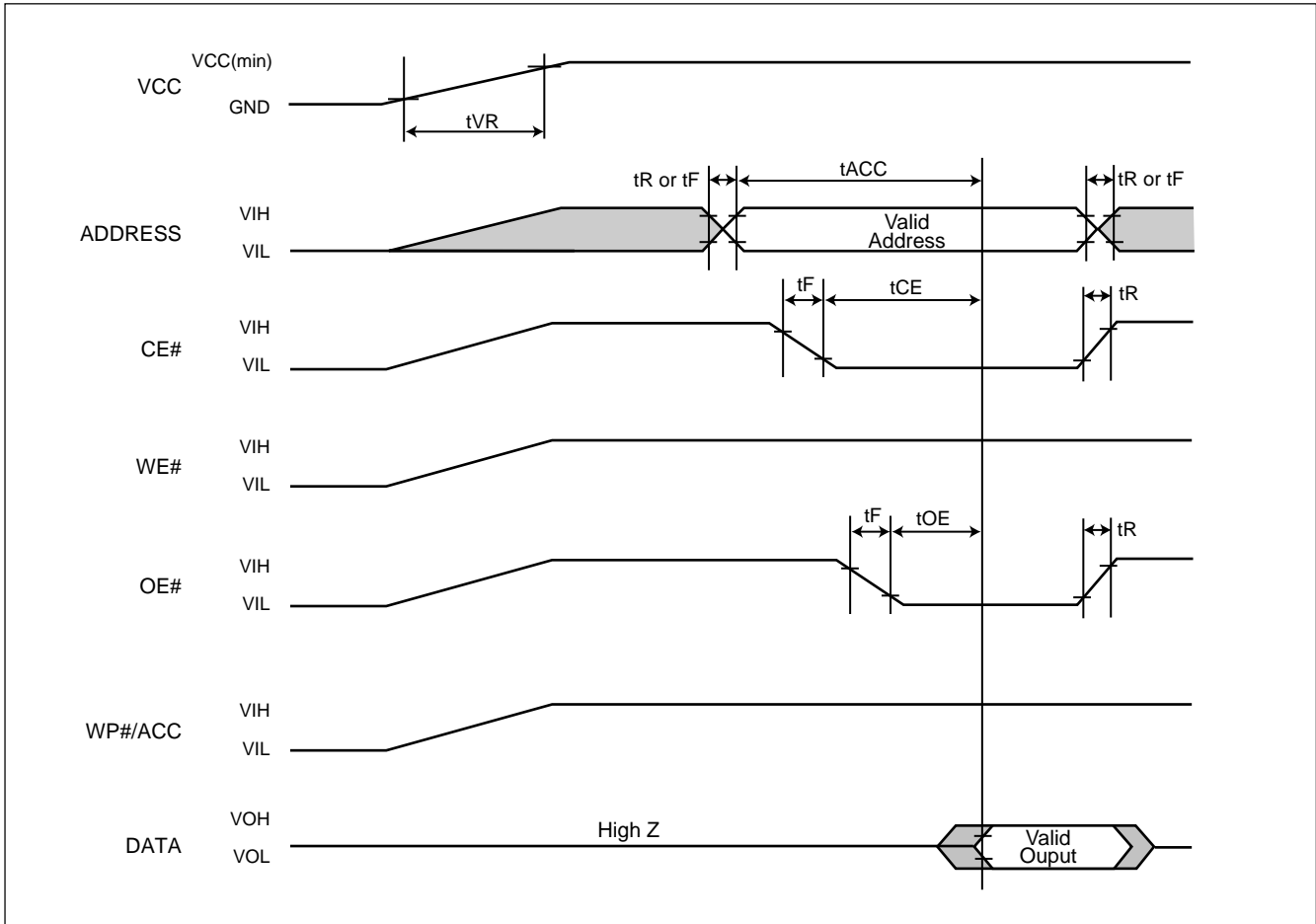

Figure A. AC Timing at Device Power-Up

Symbol	Parameter	Notes	Min.	Max.	Unit
tVR	VCC Rise Time	1	20	500000	us/V
tR	Inptut Signal Rise Time	1,2		20	us/V
tF	Inptut Signal Fall Time	1,2		20	us/V

Notes :

1. Sampled, not 100% tested.
2. This specification is applied for not only the device power-up but also the normal operations.



ERASE AND PROGRAMMING PERFORMANCE (1)

PARAMETER	LIMITS			UNITS
	MIN.	TYP.(2)	MAX.(3)	
Sector Erase Time		0.7	15	sec
Chip Erase Time		14		sec
Byte Programming Time		9	300	us
Word Programming Time		11	360	us
Chip Programming Time	Byte Mode	9	27	sec
	Word Mode	5.8	17	sec
Erase/Program Cycles	100,000			Cycles

- Note: 1. Not 100% Tested, Excludes external system level over head.
2. Typical values measured at 25° C, 3V.
3. Maximum values measured at 25° C, 2.7V.

LATCH-UP CHARACTERISTICS

	MIN.	MAX.
Input Voltage with respect to GND on OE#, RESET#, A9	-1.0V	12.5V
Input Voltage with respect to GND on all power pins, Address pins, CE# and WE#	-1.0V	VCC + 1.0V
Input Voltage with respect to GND on all I/O pins	-1.0V	VCC + 1.0V
Current	-100mA	+100mA
Includes all pins except VCC. Test conditions: VCC = 3.0V, one pin at a time.		



MX29LV800C T/B

ORDERING INFORMATION

PART NO.	ACCESS TIME (ns)	OPERATING Current MAX. (mA)	STANDBY Current MAX. (uA)	PACKAGE	Remark
MX29LV800CTMC-55R	55	30	5	44 Pin SOP	
MX29LV800CBMC-55R	55	30	5	44 Pin SOP	
MX29LV800CTMC-70	70	30	5	44 Pin SOP	
MX29LV800CBMC-70	70	30	5	44 Pin SOP	
MX29LV800CTMC-90	90	30	5	44 Pin SOP	
MX29LV800CBMC-90	90	30	5	44 Pin SOP	
MX29LV800CTTC-55R	55	30	5	48 Pin TSOP (Normal Type)	
MX29LV800CBTC-55R	55	30	5	48 Pin TSOP (Normal Type)	
MX29LV800CTTC-70	70	30	5	48 Pin TSOP (Normal Type)	
MX29LV800CBTC-70	70	30	5	48 Pin TSOP (Normal Type)	
MX29LV800CTTC-90	90	30	5	48 Pin TSOP (Normal Type)	
MX29LV800CBTC-90	90	30	5	48 Pin TSOP (Normal Type)	
MX29LV800CTXBC-55R	55	30	5	48 Ball CSP (Ball Size:0.3mm)	
MX29LV800CBXBC-55R	55	30	5	48 Ball CSP (Ball Size:0.3mm)	
MX29LV800CTXBC-70	70	30	5	48 Ball CSP (Ball Size:0.3mm)	
MX29LV800CBXBC-70	70	30	5	48 Ball CSP (Ball Size:0.3mm)	
MX29LV800CTXBC-90	90	30	5	48 Ball CSP (Ball Size:0.3mm)	
MX29LV800CBXBC-90	90	30	5	48 Ball CSP (Ball Size:0.3mm)	
MX29LV800CTMI-55R	55	30	5	44 Pin SOP	
MX29LV800CBMI-55R	55	30	5	44 Pin SOP	
MX29LV800CTMI-70	70	30	5	44 Pin SOP	
MX29LV800CBMI-70	70	30	5	44 Pin SOP	
MX29LV800CTMI-90	90	30	5	44 Pin SOP	
MX29LV800CBMI-90	90	30	5	44 Pin SOP	
MX29LV800CTTI-55R	55	30	5	48 Pin TSOP (Normal Type)	
MX29LV800CBTI-55R	55	30	5	48 Pin TSOP (Normal Type)	



MX29LV800C T/B

PART NO.	ACCESS TIME (ns)	OPERATING Current MAX. (mA)	STANDBY Current MAX. (uA)	PACKAGE	Remark
MX29LV800CTTI-70	70	30	5	48 Pin TSOP (Normal Type)	
MX29LV800CBTI-70	70	30	5	48 Pin TSOP (Normal Type)	
MX29LV800CTTI-90	90	30	5	48 Pin TSOP (Normal Type)	
MX29LV800CBTI-90	90	30	5	48 Pin TSOP (Normal Type)	
MX29LV800CTXBI-55R	55	30	5	48 Ball CSP (Ball Size:0.3mm)	
MX29LV800CBXBI-55R	55	30	5	48 Ball CSP (Ball Size:0.3mm)	
MX29LV800CTXBI-70	70	30	5	48 Ball CSP (Ball Size:0.3mm)	
MX29LV800CBXBI-70	70	30	5	48 Ball CSP (Ball Size:0.3mm)	
MX29LV800CTXBI-90	90	30	5	48 Ball CSP (Ball Size:0.3mm)	
MX29LV800CBXBI-90	90	30	5	48 Ball CSP (Ball Size:0.3mm)	
MX29LV800CTXEC-55R	55	30	5	48 Ball CSP (Ball Size:0.4mm)	
MX29LV800CBXEC-55R	55	30	5	48 Ball CSP (Ball Size:0.4mm)	
MX29LV800CTXEC-70	70	30	5	48 Ball CSP (Ball Size:0.4mm)	
MX29LV800CBXEC-70	70	30	5	48 Ball CSP (Ball Size:0.4mm)	
MX29LV800CTXEC-90	90	30	5	48 Ball CSP (Ball Size:0.4mm)	
MX29LV800CBXEC-90	90	30	5	48 Ball CSP (Ball Size:0.4mm)	
MX29LV800CTXEI-55R	55	30	5	48 Ball CSP (Ball Size:0.4mm)	
MX29LV800CBXEI-55R	55	30	5	48 Ball CSP (Ball Size:0.4mm)	
MX29LV800CTXEI-70	70	30	5	48 Ball CSP (Ball Size:0.4mm)	
MX29LV800CBXEI-70	70	30	5	48 Ball CSP (Ball Size:0.4mm)	
MX29LV800CTXEI-90	90	30	5	48 Ball CSP (Ball Size:0.4mm)	
MX29LV800CBXEI-90	90	30	5	48 Ball CSP (Ball Size:0.4mm)	



MX29LV800C T/B

PART NO.	ACCESS TIME (ns)	OPERATING Current MAX. (mA)	STANDBY Current MAX. (uA)	PACKAGE	Remark
MX29LV800CTMC-55Q	55	30	5	44 Pin SOP	PB free
MX29LV800CBMC-55Q	55	30	5	44 Pin SOP	PB free
MX29LV800CTMC-70G	70	30	5	44 Pin SOP	PB free
MX29LV800CBMC-70G	70	30	5	44 Pin SOP	PB free
MX29LV800CTMC-90G	90	30	5	44 Pin SOP	PB free
MX29LV800CBMC-90G	90	30	5	44 Pin SOP	PB free
MX29LV800CTTC-55Q	55	30	5	48 Pin TSOP (Normal Type)	PB free
MX29LV800CBTC-55Q	55	30	5	48 Pin TSOP (Normal Type)	PB free
MX29LV800CTTC-70G	70	30	5	48 Pin TSOP (Normal Type)	PB free
MX29LV800CBTC-70G	70	30	5	48 Pin TSOP (Normal Type)	PB free
MX29LV800CTTC-90G	90	30	5	48 Pin TSOP (Normal Type)	PB free
MX29LV800CBTC-90G	90	30	5	48 Pin TSOP (Normal Type)	PB free
MX29LV800CTXBC-55Q	55	30	5	48 Ball CSP (Ball Size:0.3mm)	PB free
MX29LV800CBXBC-55Q	55	30	5	48 Ball CSP (Ball Size:0.3mm)	PB free
MX29LV800CTXBC-70G	70	30	5	48 Ball CSP (Ball Size:0.3mm)	PB free
MX29LV800CBXBC-70G	70	30	5	48 Ball CSP (Ball Size:0.3mm)	PB free
MX29LV800CTXBC-90G	90	30	5	48 Ball CSP (Ball Size:0.3mm)	PB free
MX29LV800CBXBC-90G	90	30	5	48 Ball CSP (Ball Size:0.3mm)	PB free
MX29LV800CTMI-55Q	55	30	5	44 Pin SOP	PB free
MX29LV800CBMI-55Q	55	30	5	44 Pin SOP	PB free
MX29LV800CTMI-70G	70	30	5	44 Pin SOP	PB free
MX29LV800CBMI-70G	70	30	5	44 Pin SOP	PB free
MX29LV800CTMI-90G	90	30	5	44 Pin SOP	PB free
MX29LV800CBMI-90G	90	30	5	44 Pin SOP	PB free
MX29LV800CTTI-55Q	55	30	5	48 Pin TSOP (Normal Type)	PB free
MX29LV800CBTI-55Q	55	30	5	48 Pin TSOP (Normal Type)	PB free



MX29LV800C T/B

PART NO.	ACCESS TIME (ns)	OPERATING Current MAX. (mA)	STANDBY Current MAX. (uA)	PACKAGE	Remark
MX29LV800CTTI-70G	70	30	5	48 Pin TSOP (Normal Type)	PB free
MX29LV800CBTI-70G	70	30	5	48 Pin TSOP (Normal Type)	PB free
MX29LV800CTTI-90G	90	30	5	48 Pin TSOP (Normal Type)	PB free
MX29LV800CBTI-90G	90	30	5	48 Pin TSOP (Normal Type)	PB free
MX29LV800CTXBI-55Q	55	30	5	48 Ball CSP (Ball Size:0.3mm)	PB free
MX29LV800CBXBI-55Q	55	30	5	48 Ball CSP (Ball Size:0.3mm)	PB free
MX29LV800CTXBI-70G	70	30	5	48 Ball CSP (Ball Size:0.3mm)	PB free
MX29LV800CBXBI-70G	70	30	5	48 Ball CSP (Ball Size:0.3mm)	PB free
MX29LV800CTXBI-90G	90	30	5	48 Ball CSP (Ball Size:0.3mm)	PB free
MX29LV800CBXBI-90G	90	30	5	48 Ball CSP (Ball Size:0.3mm)	PB free
MX29LV800CTXEC-55Q	55	30	5	48 Ball CSP (Ball Size:0.4mm)	PB free
MX29LV800CBXEC-55Q	55	30	5	48 Ball CSP (Ball Size:0.4mm)	PB free
MX29LV800CTXEC-70G	70	30	5	48 Ball CSP (Ball Size:0.4mm)	PB free
MX29LV800CBXEC-70G	70	30	5	48 Ball CSP (Ball Size:0.4mm)	PB free
MX29LV800CTXEC-90G	90	30	5	48 Ball CSP (Ball Size:0.4mm)	PB free
MX29LV800CBXEC-90G	90	30	5	48 Ball CSP (Ball Size:0.4mm)	PB free
MX29LV800CTXEI-55Q	55	30	5	48 Ball CSP (Ball Size:0.4mm)	PB free
MX29LV800CBXEI-55Q	55	30	5	48 Ball CSP (Ball Size:0.4mm)	PB free
MX29LV800CTXEI-70G	70	30	5	48 Ball CSP (Ball Size:0.4mm)	PB free
MX29LV800CBXEI-70G	70	30	5	48 Ball CSP (Ball Size:0.4mm)	PB free
MX29LV800CTXEI-90G	90	30	5	48 Ball CSP (Ball Size:0.4mm)	PB free
MX29LV800CBXEI-90G	90	30	5	48 Ball CSP (Ball Size:0.4mm)	PB free



MX29LV800C T/B

PART NAME DESCRIPTION

MX 29 LV 800 C T T C - 70 G

OPTION:

G: Lead-free package
R: Restricted VCC (3.0V~3.6V)
Q: Restricted VCC (3.0V~3.6V) with Lead-free package
blank: normal

SPEED:

55: 55ns
70: 70ns
90: 90ns

TEMPERATURE RANGE:

C: Commercial (0°C to 70°C)
I: Industrial (-40°C to 85°C)

PACKAGE:

M: SOP
T: TSOP
X: FBGA (CSP)
|
XB - 0.3mm Ball
XE - 0.4mm Ball

BOOT BLOCK TYPE:

T: Top Boot
B: Bottom Boot

REVISION:

C

DENSITY & MODE:

800: 8M, x8/x16 Boot Block

TYPE:

L, LV: 3V

DEVICE:

28, 29: Flash

PACKAGE INFORMATION

Title: Package Outline for TSOP(I) 48L (12X20mm)NORMAL FORM

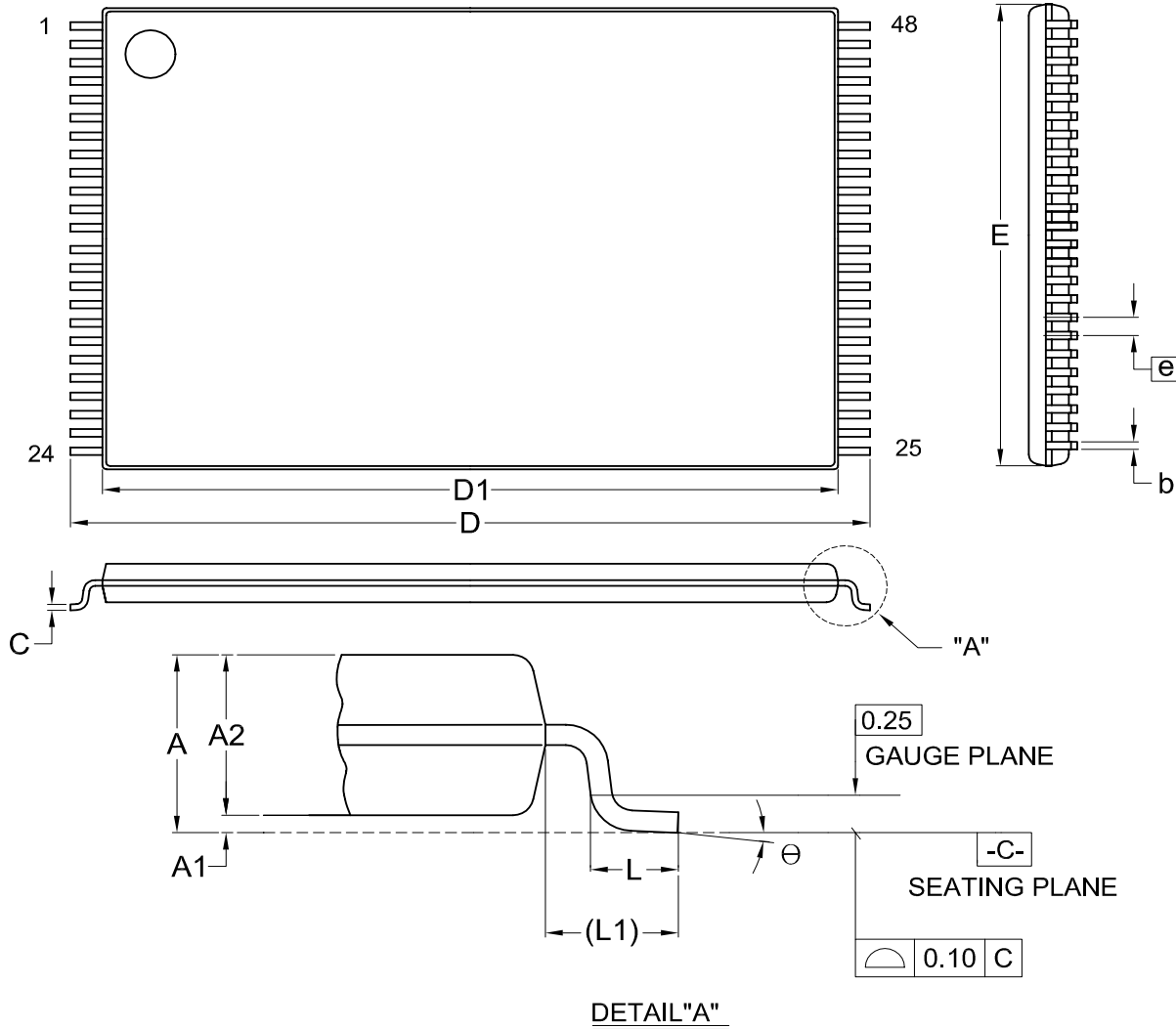

Dimensions (inch dimensions are derived from the original mm dimensions)

SYMBOL		A	A1	A2	b	C	D	D1	E	e	L	L1	θ
mm	Min.	---	0.05	0.95	0.17	0.10	19.80	18.30	11.90		0.50	0.70	0
	Nom.	---	0.10	1.00	0.20	0.13	20.00	18.40	12.00	0.50	0.60	0.80	5
	Max.	1.20	0.15	1.05	0.27	0.21	20.20	18.50	12.10		0.70	0.90	8
Inch	Min.	---	0.002	0.037	0.007	0.004	0.780	0.720	0.469		0.020	0.028	0
	Nom.	---	0.004	0.039	0.008	0.005	0.787	0.724	0.472	0.020	0.024	0.031	5
	Max.	0.047	0.006	0.041	0.011	0.008	0.795	0.728	0.476		0.028	0.035	8

DWG.NO.	REVISION	REFERENCE			ISSUE DATE
		JEDEC	EIAJ		
6110-1607	7	MO-142			12-01-'03

Title: Package Outline for SOP 44L (500MIL)

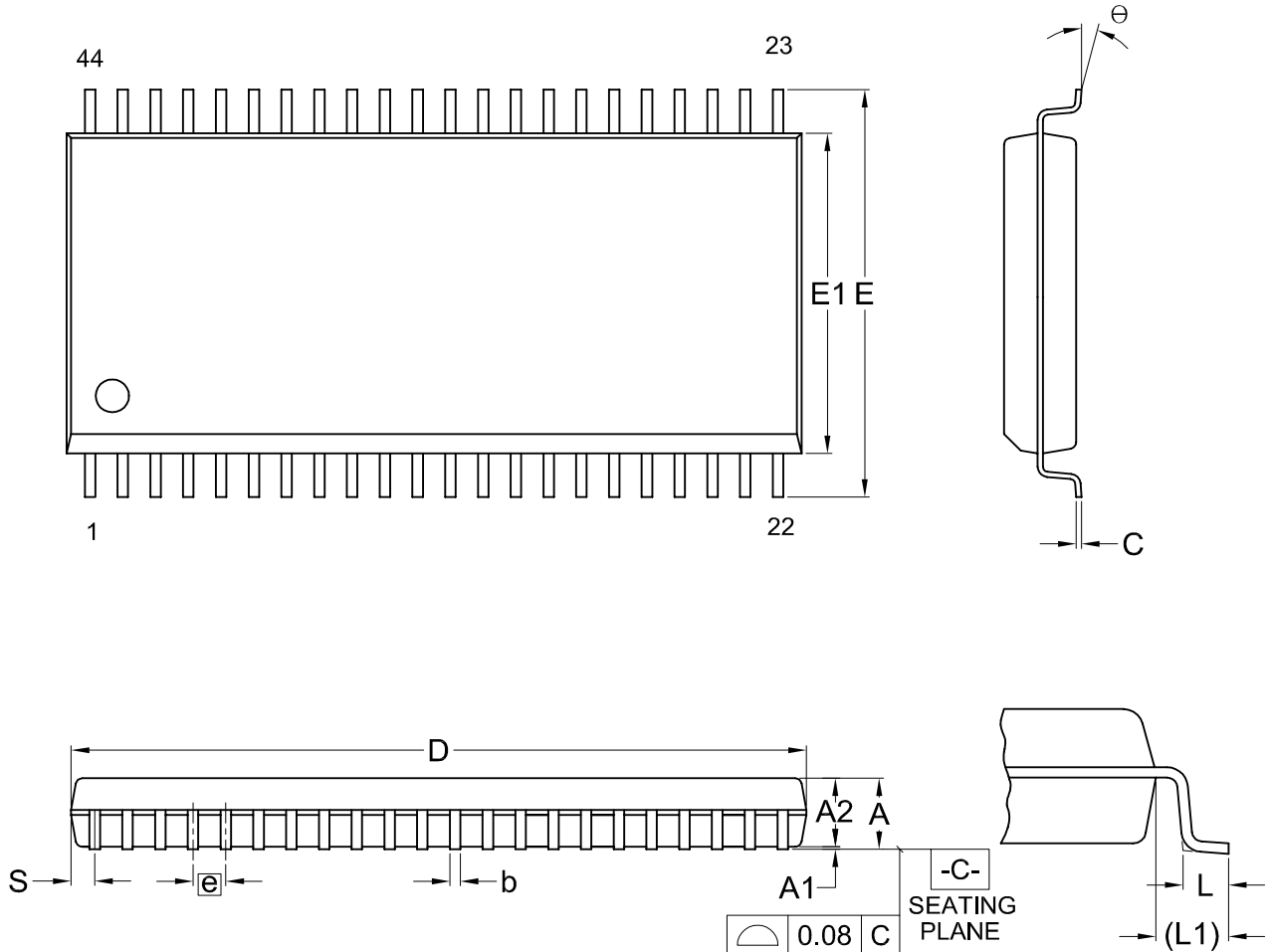

Dimensions (inch dimensions are derived from the original mm dimensions)

SYMBOL		A	A1	A2	b	C	D	E	E1	e	L	L1	S	θ
mm	Min.	---	0.10	2.59	0.36	0.15	28.37	15.83	12.47		0.56	1.51	0.78	0
	Nom.	---	0.15	2.69	0.41	0.20	28.50	16.03	12.60	1.27	0.76	1.71	0.91	5
	Max.	3.00	0.20	2.80	0.51	0.25	28.63	16.23	12.73		0.96	1.91	1.04	10
Inch	Min.	---	0.004	0.102	0.014	0.006	1.117	0.623	0.491		0.022	0.059	0.031	0
	Nom.	---	0.006	0.106	0.016	0.008	1.122	0.631	0.496	0.050	0.030	0.067	0.036	5
	Max.	0.118	0.008	0.110	0.020	0.010	1.127	0.639	0.501		0.038	0.075	0.041	10

DWG.NO.	REVISION	REFERENCE			ISSUE DATE
		JEDEC	EIAJ		
6110-1405	6	MO-175			11-26-'03

48-Ball CSP (for MX29LV800CTXBC/BTXBI/BBXBC/BBXBI)

Title: Package Outline for CSP 48BALL(6X8X1.2MM,BALL PITCH 0.8MM,BALL DIAMETER 0.3MM)

TOP VIEW

BOTTOM VIEW

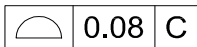
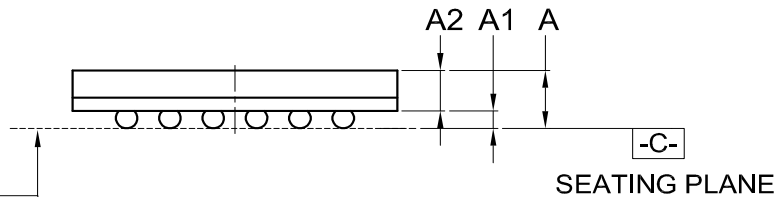
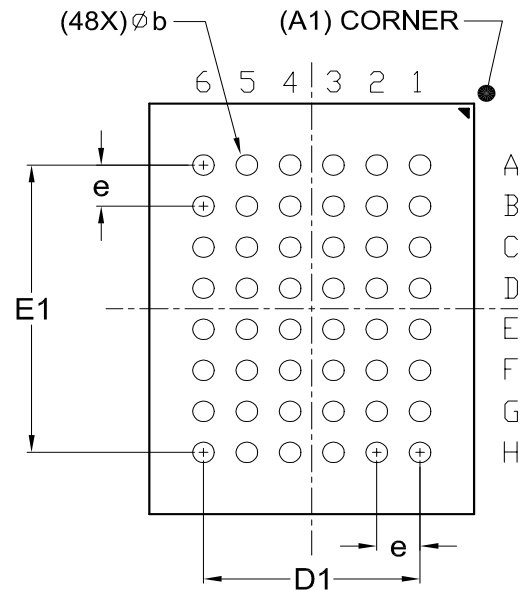
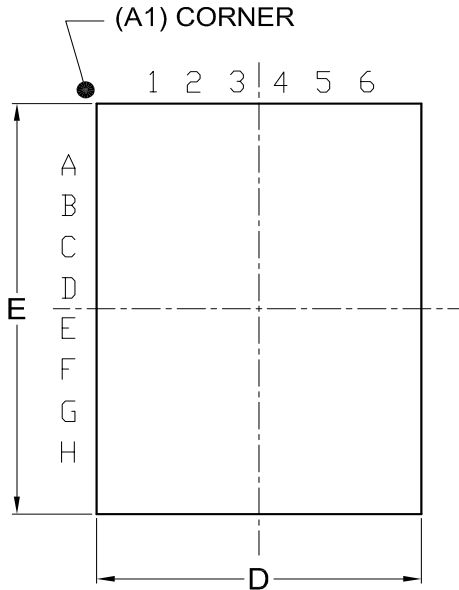

Dimensions (inch dimensions are derived from the original mm dimensions)

SYMBOL		A	A1	A2	b	D	D1	E	E1	e
mm	Min.	---	0.18	0.65	0.27	5.90		7.90		
	Nom.	---	0.23	---	0.30	6.00	4.00	8.00	5.60	0.80
	Max.	1.20	0.28	---	0.37	6.10		8.10		
Inch	Min.	---	0.007	0.026	0.011	0.232		0.311		
	Nom.	---	0.009	---	0.012	0.236	0.157	0.315	0.220	0.031
	Max.	0.047	0.011	---	0.015	0.240		0.319		

DWG.NO.	REVISION	REFERENCE			ISSUE DATE
		JEDEC	EIAJ		
6110-4201	4	MO-210			12-12-'03

48-Ball CSP (for MX29LV800CTXEC/BTXEI/BBXEC/BBXEI)

Title: Package Outline for CSP 48BALL(6X8X1.3MM,BALL PITCH 0.8MM,BALL DIAMETER 0.4MM)

TOP VIEW

BOTTOM VIEW

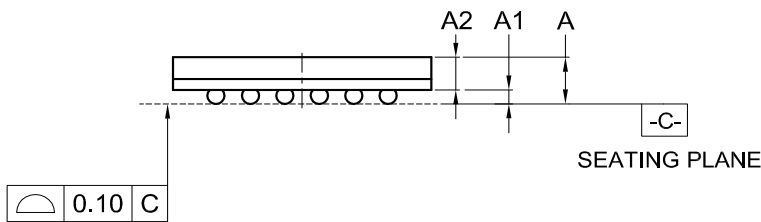
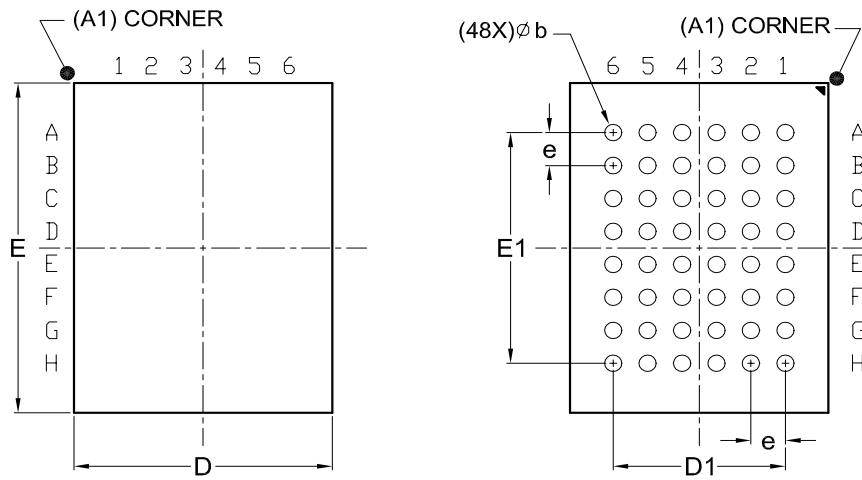

Dimensions (inch dimensions are derived from the original mm dimensions)

SYMBOL		A	A1	A2	b	D	D1	E	E1	e
mm	Min.	---	0.25	0.65	0.35	5.90		7.90		
	Nom.	---	0.30	---	0.40	6.00	4.00	8.00	5.60	0.80
	Max.	1.30	0.35	---	0.45	6.10		8.10		
Inch	Min.	---	0.010	0.026	0.014	0.232		0.311		
	Nom.	---	0.012	---	0.016	0.236	0.157	0.315	0.220	0.031
	Max.	0.051	0.014	---	0.018	0.240		0.319		

DWG.NO.	REVISION	REFERENCE			ISSUE DATE
		JEDEC	EIAJ		
6110-4202	4	MO-219			12-12-'03



REVISION HISTORY

Revision No.	Description	Page	Date
1.0	1. Removed "Preliminary"	P1	MAY/12/2005
1.1	1. Added Pb-free package information for 44-SOP 2. Added "Recommended Operating Conditions"	P57 P54	JUL/22/2005



MX29LV800C T/B

MACRONIX INTERNATIONAL Co., LTD.

Headquarters:

TEL:+886-3-578-6688

FAX:+886-3-563-2888

Europe Office :

TEL:+32-2-456-8020

FAX:+32-2-456-8021

Hong Kong Office :

TEL:+86-755-834-335-79

FAX:+86-755-834-380-78

Japan Office :

Kawasaki Office :

TEL:+81-44-246-9100

FAX:+81-44-246-9105

Osaka Office :

TEL:+81-6-4807-5460

FAX:+81-6-4807-5461

Singapore Office :

TEL:+65-6346-5505

FAX:+65-6348-8096

Taipei Office :

TEL:+886-2-2509-3300

FAX:+886-2-2509-2200

MACRONIX AMERICA, INC.

TEL:+1-408-262-8887

FAX:+1-408-262-8810

<http://www.macronix.com>
