

features

- Silver element
- Anti-leaching nickel barrier terminations
- Meets or exceeds EIA 575, EIAJ RC 2690A, EIA PDP-100, MIL-R-55342F
- Marking: White "000" on black protective coat
1H and 1E sizes are green with no marking
1J has white "0" marking
- Products with lead-free terminations meet RoHS requirements. Pb located in glass material, electrode and resistor element is exempt per Annex 1, exemption 5 of EU directive 2005/95/EC

dimensions and construction

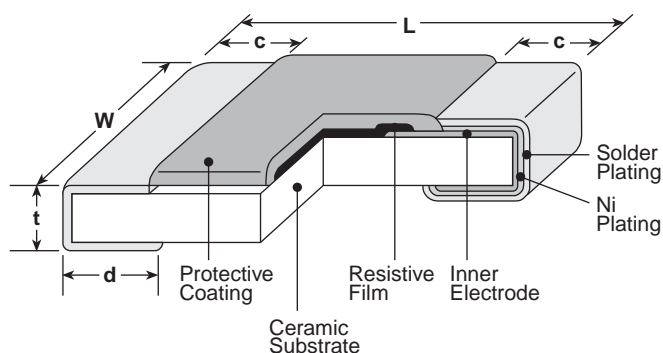

Type (Inch Size Code)	Dimensions inches (mm)				
	L	W	c	d	t
1H (0201)	.024±.001 (0.6±0.03)	.012±.001 (0.3±0.03)	.004±.002 (0.1±0.05)	.006±.002 (0.15±0.05)	.009±.002 (0.23±0.05)
1E (0402)	.039 ^{+0.004} _{-.002} (1.0 ^{+0.1} _{-.05})	.02±.002 (0.5±0.05)	.008±.004 (0.2±0.1)	.01 ^{+0.002} _{-.004} (0.25 ^{+0.05} _{-.1})	.014±.002 (0.35±0.05)
1J (0603)	.063±.008 (1.6±0.2)	.031±.004 (0.8±0.1)	.012±.004 (0.3±0.1)	.012±.004 (0.3±0.1)	.018±.004 (0.45±0.1)
2A (0805)	.079±.008 (2.0±0.2)	.049±.004 (1.25±0.1)	.016±.008 (0.4±0.2)	.012 ^{+0.008} _{-.004} (0.3 ^{+0.2} _{-.1})	.02±.004 (0.5±0.1)
2B (1206)	.126±.008 (3.2±0.2)	.063±.008 (1.6±0.2)	.02±.012 (0.5±0.3)	.016 ^{+0.008} _{-.004} (0.4 ^{+0.2} _{-.1})	.024±.004 (0.6±0.1)
2E (1210)		.102±.008 (2.6±0.2)			
2H (2010)	.197±.008 (5.0±0.2)	.098±.008 (2.5±0.2)			
3A (2512)	.248±.008 (6.3±0.2)	.122±.008 (3.1±0.2)			

ordering information

New Part #	RK73Z	2B	T	TD
Type		Size	Termination Material	Packaging
		1H 1E 1J 2A 2B 2E 2H 3A	T: Sn (1H, 1E, 1J, 2A, 2B, 2E, 2H, 3A) L: SnPb (1E, 1J, 2A, 2B, 2E, 2H, 3A) (Other termination styles may be available, please contact factory for options)	TC: 2mm pitch pressed paper (0201 only) TP: 2mm pitch punched paper (0402, 0603 & 0805) TD: 7" paper tape (0603, 0805, 1206 & 1210) TDD: 10" paper tape (0603, 0805, 1206 & 1210) TE: 7" punched plastic (0805, 1206, 1210, 2010 & 2512) TED: 10" punched plastic (0805, 1206, 1210, 2010 & 2512)

For further information on packaging, please refer to Appendix A.

applications and ratings

Part Designation	Maximum Continuous Current @ 70°C	Maximum Surge Current @ 70°C	Maximum Resistance	Operating Temperature Range
RK73Z1H	0.5 Amps	1.0 Amp Max. for < 1 second	50mΩ	-55°C to +125°C
RK73Z1E RK73Z1J	1.0 Amps	2 Amp Max. for < 1 second		-55°C to +155°C
RK73Z2A	2.0 Amps	5 Amp Max. for < 1 second		
RK73Z2B RK73Z2E RK73Z2H RK73Z3A	2.0 Amps	10 Amp Max. for < 1 second		

environmental applications

Derating Curve

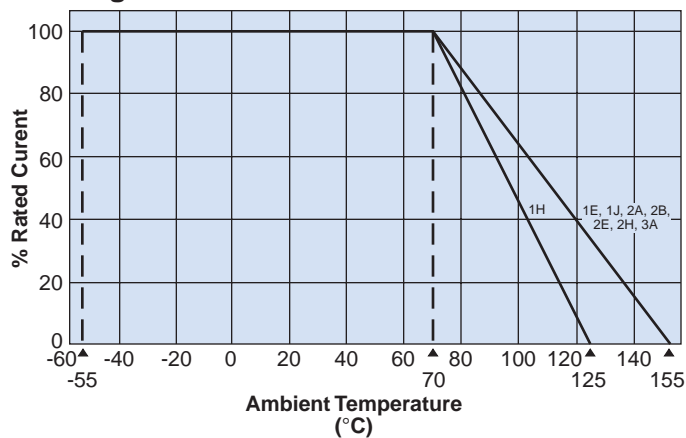

For resistors operated at an ambient temperature of 70°C or above, a current rating shall be derated in accordance with the above derating curve.

For complete environmental specifications, please refer to pages 30-31.