

Multilayer ceramic capacitors are available in a variety of physical sizes and configurations, including leaded devices and surface mounted chips. Leaded styles include molded and conformally coated parts with axial and radial leads. However, the basic capacitor element is similar for all styles. It is called a chip and consists of formulated dielectric materials which have been cast into thin layers, interspersed with metal electrodes alternately exposed on opposite

edges of the laminated structure. The entire structure is fired at high temperature to produce a monolithic block which provides high capacitance values in a small physical volume. After firing, conductive terminations are applied to opposite ends of the chip to make contact with the exposed electrodes. Termination materials and methods vary depending on the intended use.

**TEMPERATURE CHARACTERISTICS**

Ceramic dielectric materials can be formulated with a wide range of characteristics. The EIA standard for ceramic dielectric capacitors (RS-198) divides ceramic dielectrics into the following classes:

**Class I:** Temperature compensating capacitors, suitable for resonant circuit application or other applications where high Q and stability of capacitance characteristics are required. Class I capacitors have predictable temperature coefficients and are not effected by voltage, frequency or time. They are made from materials which are not ferro-electric, yielding superior stability but low volumetric efficiency. Class I capacitors are the most stable type available, but have the lowest volumetric efficiency.

**Class II:** Stable capacitors, suitable for bypass or coupling applications or frequency discriminating circuits where Q and stability of capacitance characteristics are not of major importance. Class II capacitors have temperature characteristics of  $\pm 15\%$  or less. They are made from materials which are ferro-electric, yielding higher volumetric efficiency but less stability. Class II capacitors are affected by temperature, voltage, frequency and time.

**Class III:** General purpose capacitors, suitable for by-pass coupling or other applications in which dielectric losses, high insulation resistance and stability of capacitance characteristics are of little or no importance. Class III capacitors are similar to Class II capacitors except for temperature characteristics, which are greater than  $\pm 15\%$ . Class III capacitors have the highest volumetric efficiency and poorest stability of any type.

KEMET leaded ceramic capacitors are offered in the three most popular temperature characteristics:

**C0G:** Class I, with a temperature coefficient of  $0 \pm 30$  ppm per degree C over an operating temperature range of  $- 55^{\circ}\text{C}$  to  $+ 125^{\circ}\text{C}$  (Also known as "NP0").

**X7R:** Class II, with a maximum capacitance change of  $\pm 15\%$  over an operating temperature range of  $- 55^{\circ}\text{C}$  to  $+ 125^{\circ}\text{C}$ .

**Z5U:** Class III, with a maximum capacitance change of  $+ 22\% - 56\%$  over an operating temperature range of  $+ 10^{\circ}\text{C}$  to  $+ 85^{\circ}\text{C}$ .

Specified electrical limits for these three temperature characteristics are shown in Table 1.

**SPECIFIED ELECTRICAL LIMITS**

PARAMETER	TEMPERATURE CHARACTERISTICS		
	C0G	X7R	Z5U
Dissipation Factor: Measured at following conditions: C0G — 1 kHz and 1 vrms if capacitance > 1000 pF 1 MHz and 1 vrms if capacitance $\leq$ 1000 pF X7R — 1 kHz and 1 vrms* or if extended cap range 0.5 vrms Z5U — 1 kHz and 0.5 vrms	0.15%	2.5%	4.0%
Dielectric Strength: 2.5 times rated DC voltage.	Pass Subsequent IR Test		
Insulation Resistance (IR): At rated DC voltage, whichever of the two is smaller	1,000 M $\Omega$ - $\mu$ F or 100 G $\Omega$	1,000 M $\Omega$ - $\mu$ F or 100 G $\Omega$	1,000 M $\Omega$ - $\mu$ F or 10 G $\Omega$
Temperature Characteristics: Range, $^{\circ}\text{C}$ Capacitance Change without DC voltage	-55 to +125 $0 \pm 30$ ppm/ $^{\circ}\text{C}$	-55 to +125 $\pm 15\%$	+10 to +85 $+22\%, -56\%$

\* 1 MHz and 1 vrms if capacitance  $\leq$  100 pF on military product.

Table I

### GENERAL SPECIFICATIONS

#### Working Voltage:

	Axial (WVDC)	Radial (WVDC)
C0G	50 & 100	50, 100, 200, 500, 1k, 1.5k, 2k, 2.5k, 3k
X7R	50 & 100	50, 100, 200, 500, 1k, 1.5k, 2k, 2.5k, 3k
Z5U	50 & 100	50 & 100

#### Temperature Characteristics:

C0G – 0 ± 30 PPM / °C from - 55°C to + 125°C (1)  
 X7R – ± 15% from - 55°C to + 125°C  
 Z5U – + 22% / -56% from + 10°C to + 85°C

#### Capacitance Tolerance:

C0G – ±0.5pF, ±1%, ±2%, ±5%, ±10%  
 X7R – ±10%, ±20%, +80% / -20%, +100% / -0%  
 Z5U – ±20%, +80% / -20%

#### Construction:

**Epoxy encapsulated - meets flame test requirements of UL Standard 94V-0.**

High-temperature solder - meets EIA RS-198, Method 302, Condition B (260°C for 10 seconds)

#### Lead Material:

100% matte tin (Sn) with nickel (Ni) underplate and steel core.

#### Solderability:

**EIA RS-198, Method 301, Solder Temperature: 230°C ±5°C.**  
 Dwell time in solder = 7 ± ½ seconds.

#### Terminal Strength:

**EIA RS-198, Method 303, Condition A (2.2kg)**

### ELECTRICAL

#### Capacitance @ 25°C:

**Within specified tolerance and following test conditions.**

C0G – > 1000pF with 1.0 vrms @ 1 kHz  
 ≤ 1000pF with 1.0 vrms @ 1 MHz  
 X7R – with 1.0 vrms @ 1 kHz  
 Z5U – with 1.0 vrms @ 1 kHz

#### Dissipation Factor @ 25°C:

**Same test conditions as capacitance.**

C0G – 0.15% maximum  
 X7R – 2.5% maximum  
 Z5U – 4.0% maximum

#### Insulation Resistance @ 25°C:

**EIA RS-198, Method 104, Condition A <1kV**

C0G – 100k Megohm or 1000 Megohm x μF, whichever is less.  
 ≤500V test @ rated voltage, ≥1kV test @ 500V  
 X7R – 100k Megohm or 1000 Megohm x μF, whichever is less.  
 ≤500V test @ rated voltage, ≥1kV test @ 500V  
 Z5U – 10k Megohm or 1000 Megohm x μF, whichever is less.

#### Dielectric Withstanding Voltage:

**EIA RS-198, Method 103**

≤200V test @ 250% of rated voltage for 5 seconds with current limited to 50mA.  
 500V test @ 150% of rated voltage for 5 seconds with current limited to 50mA.  
 ≥1000V test @ 120% of rated voltage for 5 seconds with current limited to 50mA.

### ENVIRONMENTAL

#### Vibration:

**EIA RS-198, Method 304, Condition D (10-2000Hz; 20g)**

#### Shock:

**EIA RS-198, Method 305, Condition I (100g)**

#### Life Test:

**EIA RS-198, Method 201, Condition D. ≤ 200V**

C0G – 200% of rated voltage @ +125°C  
 X7R – 200% of rated voltage @ +125°C  
 Z5U – 200% of rated voltage @ +85°C

#### ≥ 500V

C0G – rated voltage @ +125°C  
 X7R – rated voltage @ +125°C

#### Post Test Limits @ 25°C are:

##### Capacitance Change:

C0G (≤ 200V) – +3% or 0.25pF, whichever is greater.  
 C0G (≥ 500V) – +3% or 0.50pF, whichever is greater.  
 X7R – + 20% of initial value (2)  
 Z5U – + 30% of initial value (2)

##### Dissipation Factor:

C0G – 0.15% maximum  
 X7R – 2.5% maximum  
 Z5U – 4.0% maximum

##### Insulation Resistance:

C0G – 10k Megohm or 100 Megohm x μF, whichever is less.  
 ≥1kV tested @ 500V.  
 X7R – 10k Megohm or 100 Megohm x μF, whichever is less.  
 ≥1kV tested @ 500V.  
 Z5U – 1k Megohm or 100 Megohm x μF, whichever is less.

#### Moisture Resistance:

**EIA RS-198, Method 204, Condition A (10 cycles without applied voltage.)**

#### Post Test Limits @ 25°C are:

##### Capacitance Change:

C0G (≤ 200V) – +3% or 0.25pF, whichever is greater.  
 C0G (≥ 500V) – +3% or 0.50pF, whichever is greater.  
 X7R – + 20% of initial value (2)  
 Z5U – + 30% of initial value (2)

##### Dissipation Factor:

C0G – 0.25% maximum  
 X7R – 3.0% maximum  
 Z5U – 4.0% maximum

##### Insulation Resistance:

C0G – 10k Megohm or 100 Megohm x μF, whichever is less.  
 ≤500V test @ rated voltage, ≥1kV test @ 500V.  
 X7R – 10k Megohm or 100 Megohm x μF, whichever is less.  
 ≥500V test @ rated voltage, >1kV test @ 500V.  
 Z5U – 1k Megohm or 100 Megohm x μF, whichever is less.

#### Thermal Shock:

**EIA RS-198, Method 202, Condition B (C0G & X7R: -55°C to +125°C); Condition A (Z5U: -55°C to 85°C)**

- (1) +53 PPM -30 PPM/ °C from +25°C to -55°C, + 60 PPM below 10pF.
- (2) X7R and Z5U dielectrics exhibit aging characteristics; therefore, it is highly recommended that capacitors be deaged for 2 hours at 150°C and stabilized at room temperature for 48 hours before capacitance measurements are made.

**STANDARD LEAD CONFIGURATION — OUTLINE DRAWINGS**

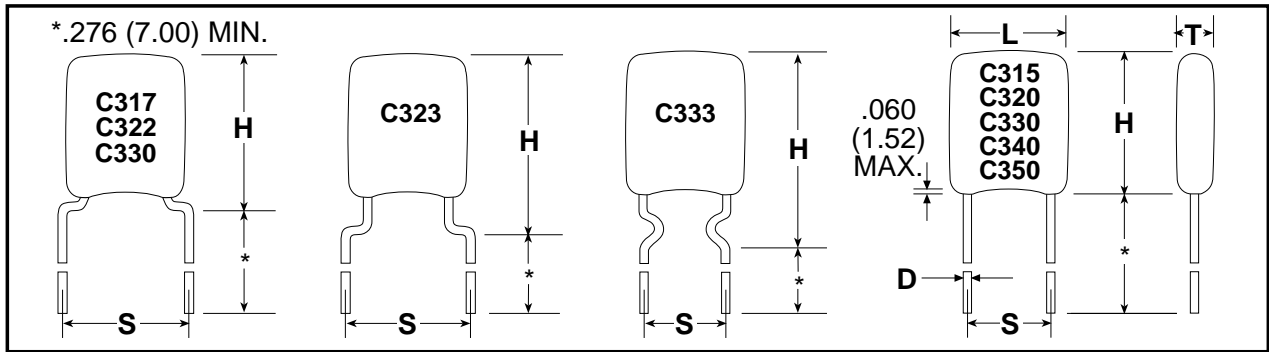

Drawings are not to scale. See table below for dimensions.  
 See page 10 for optional lead configurations.

**DIMENSIONS — INCHES & MILLIMETERS**

CASE SIZE	L MAX.	H MAX.	T MAX.	S(1) ±.030 (.78)	D +.004 (.10)-.001 (.025)
C315	.150 (3.81)	.210 (5.33)	.130 (3.30)	.100 (2.54)	.020 (.51)
C317	.150 (3.81)	.230 (5.84)	.130 (3.30)	.200 (5.08)	.020 (.51)
C320	.200 (5.08)	.260 (6.60)	.150 (3.81)	.100 (2.54)	.020 (.51)
C322	.200 (5.08)	.260 (6.60)	.150 (3.81)	.200 (5.08)	.020 (.51)
C323	.200 (5.08)	.320 (8.13)	.150 (3.81)	.200 (5.08)	.020 (.51)
C330	.300 (7.62)	.360 (9.14)	.200 (5.08)	.200 (5.08)	.020 (.51)
C333	.300 (7.62)	.390 (9.91)	.200 (5.08)	.200 (5.08)	.020 (.51)
C340	.400 (10.16)	.460 (11.68)	.200 (5.08)	.200 (5.08)	.020 (.51)
C350	.500 (12.70)	.560 (14.22)	.250 (6.35)	.400 (10.16)	.025 (.64)

NOTE: 1 inch = 25.4 mm.  
 NOTE: (1) Measured at seating plane.

**ORDERING INFORMATION**

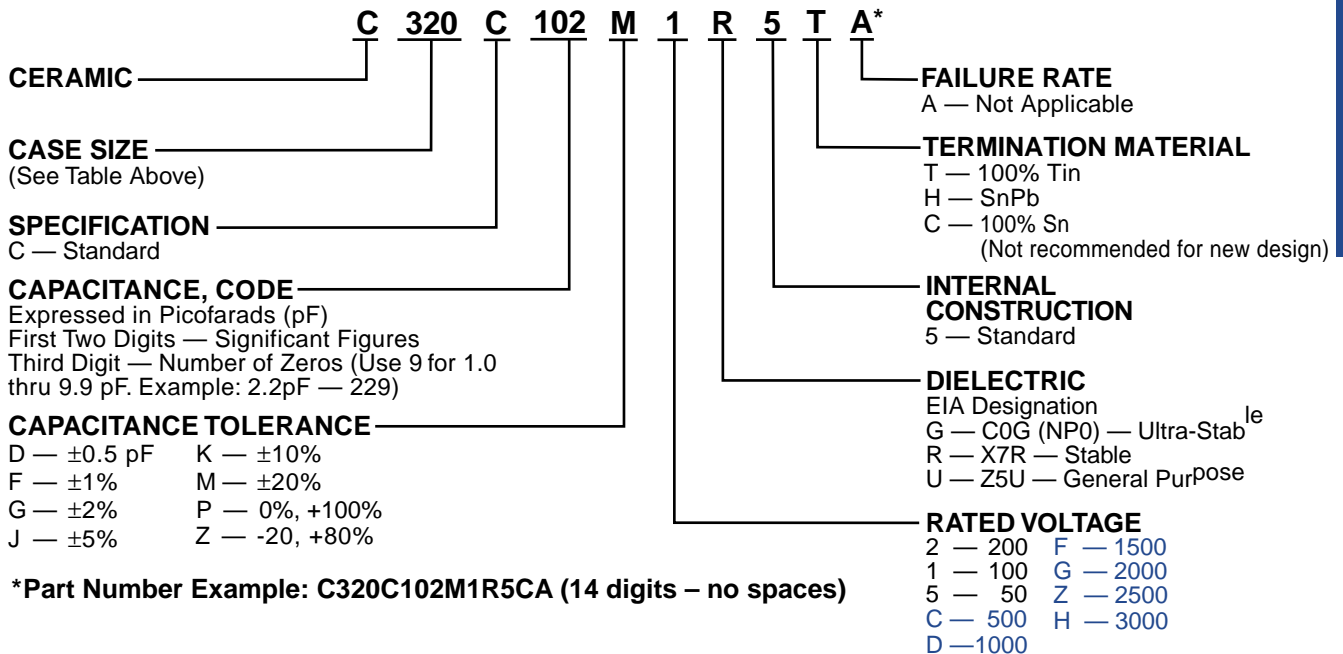

For packaging information, see pages 40, and 41.

**OPTIONAL CONFIGURATIONS BY LEAD SPACING**

The preferred lead wire configurations are shown on page 9. However, additional configurations are available. All available options, including those on page 9, are shown below grouped by lead spacing.

<b>Lead Spacing</b> <b>.100" ± .030</b>	<b>C 3 1 5</b> 	<b>C 3 1 6</b> 	<b>C 3 2 0</b> 	<b>C 3 2 4</b> 	<b>C 3 2 6</b> 	
	<b>Lead Spacing</b> <b>.200" ± .030</b>	<b>C 3 1 7</b> 	<b>C 3 1 8</b> 	<b>C 3 2 2</b> 	<b>C 3 2 3</b> 	
<b>Lead Spacing</b> <b>.200" ± .030</b>	<b>C 3 2 5</b> 	<b>C 3 2 7</b> 	<b>C 3 2 8</b> 			
<b>Lead Spacing</b> <b>.200" ± .030</b>  Note: C330 Shoulder bead leads: X7R/50V 683-105 Z5U/100V 683-334	<b>C 3 3 0</b> 	<b>C 3 3 3</b> 	<b>C 3 3 5</b> 	<b>C 3 3 6</b> 	<b>C 3 4 0</b> 	<b>C 3 4 6</b> 
<b>Lead Spacing</b> <b>.250" ± .030</b> <b>(Available in bulk only)</b>	<b>C 3 2 1</b> 	<b>C 3 3 1</b> 	<b>Lead Spacing</b> <b>.400" ± .030</b> <b>(Available in bulk only)</b>		<b>C 3 5 0</b> 	<b>C 3 5 6</b> 

**Note: Non-standard lead lengths are available in bulk only.**







**RATINGS & PART NUMBER REFERENCE**  
**GENERAL PURPOSE TEMPERATURE CHARACTERISTIC – Z5U**

Cap	Cap Code	Style Cap Tol	C31X			C32X			C33X			C34X			C35X		
			WWDC			WWDC			WWDC			WWDC			WWDC		
			50	100	200	50	100	200	50	100	200	50	100	200	50	100	200
1000pF	102	M,P,Z															
1200	122	M,P,Z															
1500	152	M,P,Z															
1800	182	M,P,Z															
2200	222	M,P,Z															
2700	272	M,P,Z															
3300	332	M,P,Z															
3900	392	M,P,Z															
4700	472	M,P,Z															
5600	562	M,P,Z															
6800	682	M,P,Z															
8200	822	M,P,Z															
.010uF	103	M,P,Z															
.012	123	M,P,Z															
.015	153	M,P,Z															
.018	183	M,P,Z															
.022	223	M,P,Z															
.027	273	M,P,Z															
.033	333	M,P,Z															
.039	393	M,P,Z															
.047	473	M,P,Z															
.056	563	M,P,Z															
.068	683	M,P,Z															
.082	823	M,P,Z															
.10	104	M,P,Z															
.12	124	M,P,Z															
.15	154	M,P,Z															
.18	184	M,P,Z															
.22	224	M,P,Z															
.27	274	M,P,Z															
.33	334	M,P,Z															
.39	394	M,P,Z															
.47	474	M,P,Z															
.56	564	M,P,Z															
.68	684	M,P,Z															
.82	824	M,P,Z															
1.0	105	M,P,Z															
1.2	125	M,P,Z															
1.5	155	M,P,Z															
1.8	185	M,P,Z															
2.2	225	M,P,Z															
2.7	275	M,P,Z															
3.3	335	M,P,Z															
3.9	395	M,P,Z															
4.7	475	M,P,Z															
5.6	565	M,P,Z															
6.8	685	M,P,Z															

C330 shoulder bend lead configuration is standard for these cap codes.

**For packaging information, see pages 40 and 41.**

**Ceramic Axial**  
Lead Tape and Reel Packaging

KEMET offers standard reeling of Molded and Conformally Coated Axial Leaded Ceramic Capacitors for automatic insertion or lead forming machines per EIA specification RS-296. KEMET'S internal specification four-digit suffix, 7200, is placed at the end of the part number to designate tape and reel packaging, ie: C410C104Z5U5CA7200.

Paper (50 lb.) test minimum is inserted between the layers of capacitors wound on reels for component pitch  $\leq 0.400"$ . Capacitor lead length may extend only a maximum of  $.0625"$  (1.59mm) beyond the tapes' edges. Capacitors are centered in a row between the two tapes and will deviate only  $\pm 0.031$  (0.79mm) from the row center. A minimum of 36" (91.5 cm) leader tape is provided at each end of the reel capacitors. Universal splicing clips are used to connect the tape. Standard reel quantities are shown on page 41.

Figure 1

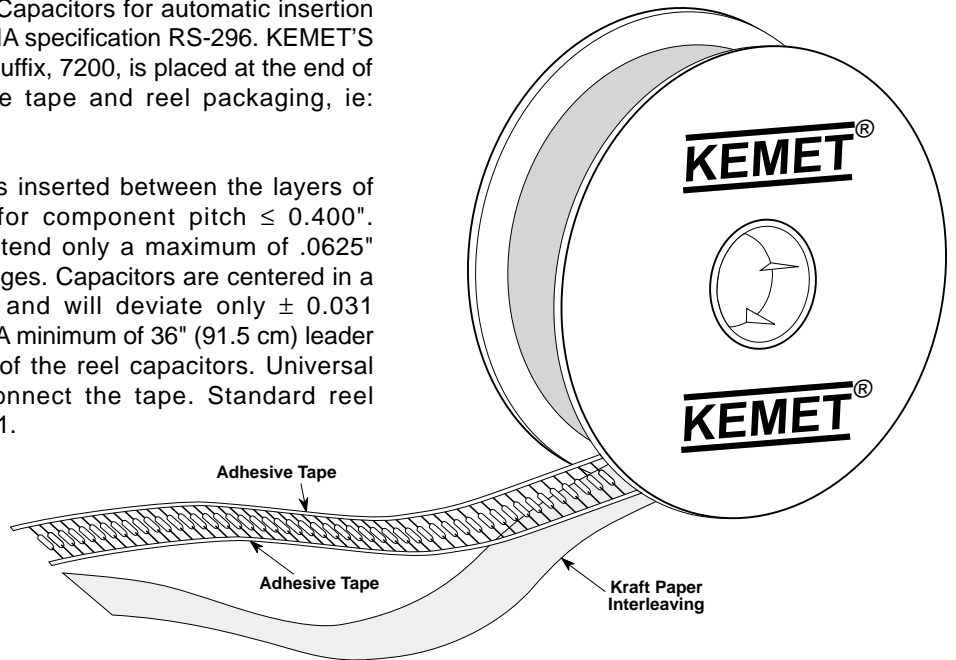

Figure 2

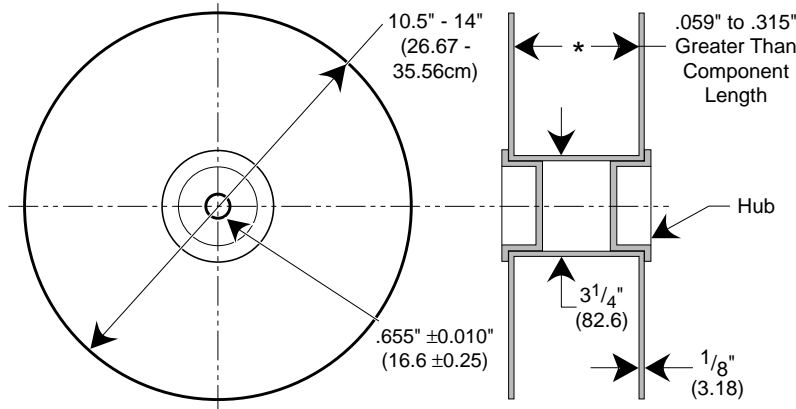
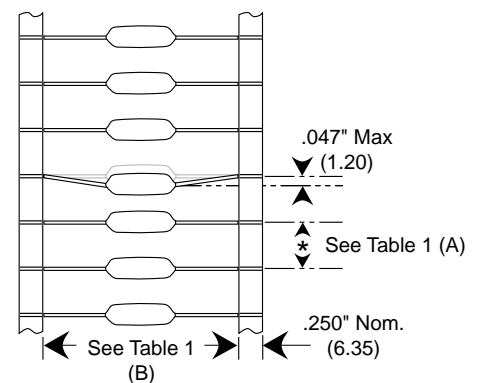

Figure 3



**Table 1** Dimensions in Inches & (Millimeters)

Component Body Diameter	Component Pitch "A"	Inside Tape Spacing "B" $\pm 1.5\text{mm}$ (0.059")	
		I	III*
0" (0mm) to 0.197" (5mm) 0.197" (5.01mm) to 0.394" (10mm)	0.197" or (5mm) 0.394" or (10mm)	2.062" (52.4mm)	2.874" (73mm)

\* Not Available for Conformally Coated Parts.

Tape and Reel Packaging

## Ceramic Radial Lead Tape and Reel Packaging

KEMET offers standard reeling of Molded and Conformally Coated Radial Leaded Ceramic Capacitors for automatic insertion per EIA specification RS-468. Parts are taped to a tagboard carrier strip, and wound on a reel as shown in Figure 1. Kraft paper interleaving is inserted between the layers of capacitors on the reel. Ammopack is also available, with the same lead tape configuration and package quantities.

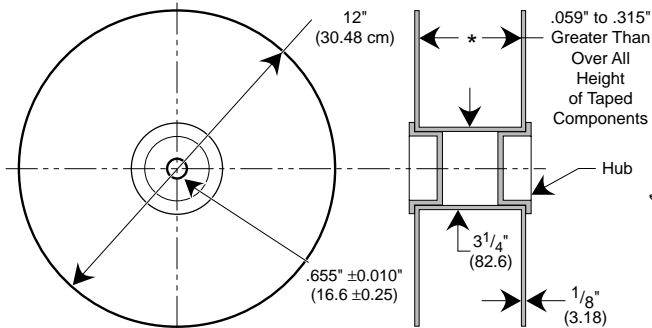

Figure 3: Standard Reel

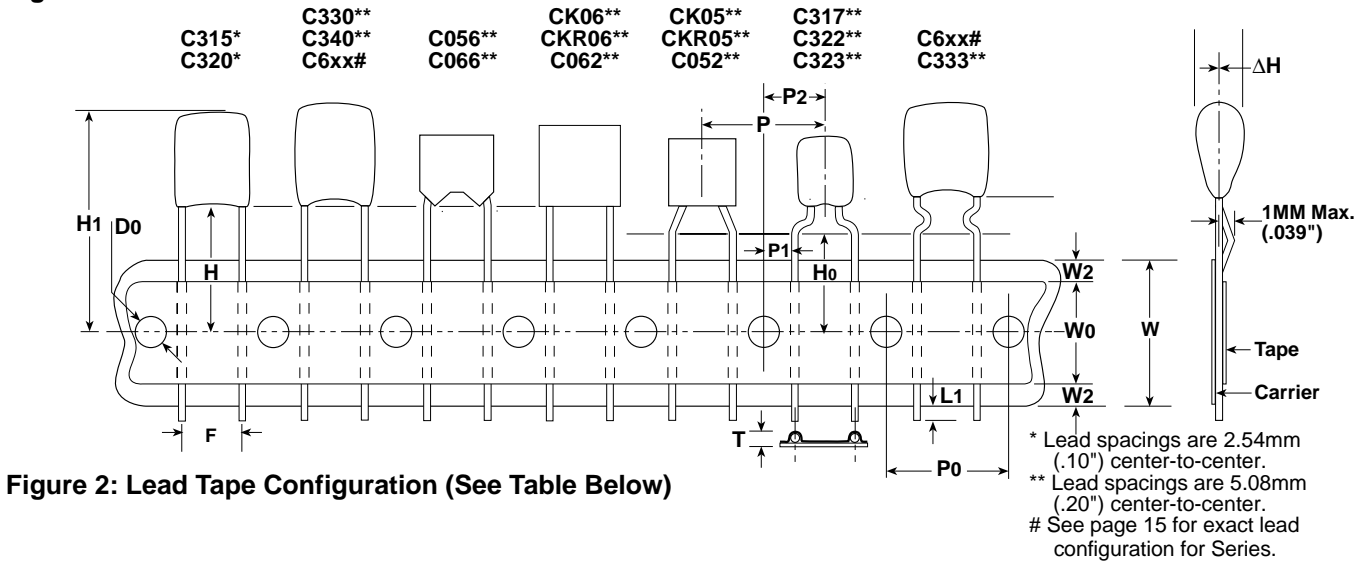
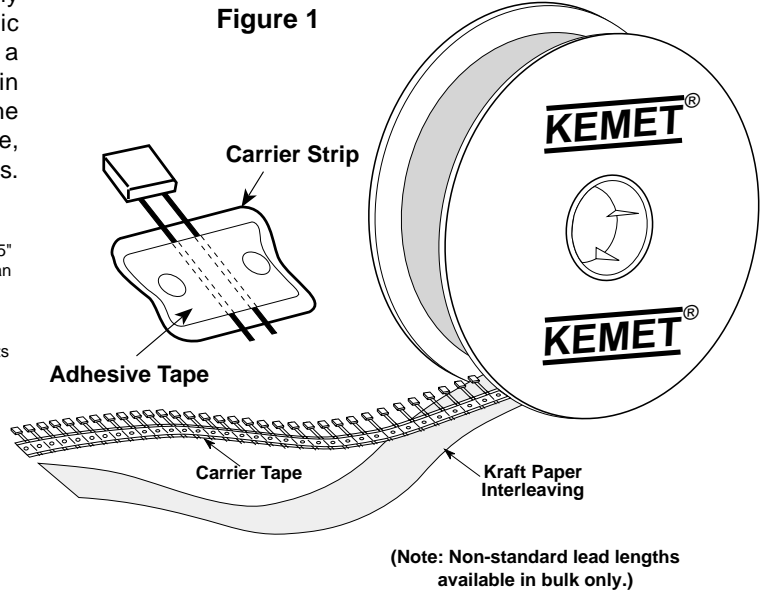

Figure 2: Lead Tape Configuration (See Table Below)

### Ceramic Radial Tape and Reel Dimensions in Millimeters & (Inches)

Dimension	Symbol	Nominal mm (inch)	Tolerance mm (inch)	Dimension	Symbol	Nominal mm (inch)	Tolerance mm (inch)
Sprocket Hole Diameter	Do	4.0 (.157)	± 0.2 (.008)	Height to Seating Plane (formed leads) (2)	H0	7301 7303 16.0 (.630) 18.0 (.709)	7301 7303 ±0.5 (.020) Minimum
Sprocket Hole Pitch	P0	12.7 (.500)	± 0.3 (.012)	Component Alignment	Δh	4.0 (.157)	±0.2 (.008)
Component Pitch	P	12.7 (.500)	± 0.3 (.012)	Lead Protrusion	L1	1.0 (.039)	Maximum
Lead Spacing (1)	F	5.08 (.20) 2.54 (.10)	+0.6 -0.2 (+.024 -.008)	Composite Tape Thickness	t	0.7 (.051)	±0.2 (.008)
Sprocket Hole Center to Lead Center (1)	P1	3.81 (.150) 5.08 (.200)	± 0.7 (.028)	Overall Tape and Lead Thickness	T	1.5 (.059)	Maximum
Sprocket Hole Center to Component Center	P2	6.35 (.250)	± 1.3 (.051)	Carrier Tape Width	W	18.0 (.709)	+1.0 - 0.5 (+.039 -.020)
Height to Seating Plane (straight leads) (2)	H	7301 7303 16.0 (.630) 18.0 (.709)	7301 7303 ±0.5 (.020) Minimum	Hold-Down Tape Width	W0	5.0 (.197)	Minimum
Component Height Above Tape Center	H1	32.2 (1.27)	Maximum	Hold-Down Tape Location	W2	3.0 (.118)	Maximum

(1) Measured at the egress from the carrier tape, on the component side.  
 (2) Determined by a 4 digit suffix placed at the end of the part number, as follows:  
 7301 = Recommended for parts with formed leads. Example: C322C104K5R5CA7301  
 7303 = Recommended for parts with straight leads. Example: C320C104K5R5CA7303

<b>CERAMIC PACKAGING</b>						
<b>KEMET Series</b>	<b>Military Style</b>	<b>Military Specification</b>	<b>Standard (1) Bulk Quantity</b>	<b>Ammo Pack Quantity</b>	<b>Standard Reel Quantity</b>	<b>Reel Size</b>
C114C-K-G	CK12, CC75	MIL-C-11015/	200/Box		5000	12"
C124C-K-G	CK13, CC76	MIL-PRF-20	200/Box		5000	12"
C192C-K-G	CK14, CC77		100/Box		3000	12"
C202C-K	CK15		25/Box		500	12"
C222C-K	CK16		10/Tray		300	12"
C052C-K-G	CK05, CC05		100/Bag	2000	2000	12"
C062C-K-G	CK06, CC06		100/Bag	1500	1500	12"
C114G	CCR75	MIL-PRF-20	200/Box		5000	12"
C124G	CCR76		200/Box		5000	12"
C192G	CCR77		100/Box		3000	12"
C202G	CC78-CCR78		25/Box		500	12"
C222G	CC79-CCR79		10/Tray		300	12"
C052/56G	CCR05		100/Bag		1700	12"
C062/66G	CCR06		100/Bag		1500	12"
C512G	CC07-CCR07		Footnote (2)		N/A	N/A
C522G	CC08-CCR08		Footnote (2)		N/A	N/A
C114T	CKR11	MIL-PRF-39014	200/Box		5000	12"
C124T	CKR12		200/Box		5000	12"
C192T	CKR14		100/Box		3000	12"
C202T	CKR15		25/Box		500	12"
C222T	CKR16		10/Tray		300	12"
C052/56T	CKR05		100/Bag		1700	12"
C062/66T	CKR06		100/Bag		1500	12"
C31X			500/Bag	2500	2500	12"
C32X			500/Bag	2500	2500	12"
C33X			250/Bag	1500	1500	12"
C340			100/Bag	1000	1000	12"
C350			50/Bag	N/A	N/A	N/A
C410			300/Box	4000	5000	12"
C412			200/Box	4000	5000	12"
C420			300/Box	4000	5000	12"
C430			200/Box	2000	2500	12"
C440			200/Box	2000	2500	12"
C512	N/A	N/A	Footnote (2)		N/A	N/A
C522	N/A	N/A	Footnote (2)		N/A	N/A
C617			500/Bag		1000	12"
C622/C623			500/Bag		1000	12"
C627/C628			500/Bag		1000	12"
C630/C631			250/Bag		1000	12"
C637/C638			250/Bag		1000	12"
C640/C641			100/Bag		500	12"
C642/C643			100/Bag		500	12"
C647/C648			100/Bag		500	12"
C657/C658			50/Bag		500	12"
C667/C668			50/Bag		500	12"

NOTE: (1) Standard packaging refers to number of pieces per bag, tray or vial.  
(2) Quantity varies. For further details, please consult the factory.

Tape and Reel Packaging