

VOLTAGE DETECTOR

Function of this IC is accurately resetting the system after detecting voltage at the time of switching power on and instantaneous power off in various CPU systems and other logic systems.

FEATURES

- Current Consumption is Low. $I_{CCL}=300\mu A$ Typ. $I_{CCH}=30\mu A$ Typ.
- Resetting Output Minimum Guarantee Voltage is Low 0.8V Typ.
- Hysteresis Voltage is Provided. 50mV Typ.
- Reset Signal Generation Starting Voltages:

KIA7019AP/AF	1.9V Typ.	KIA7033AP/AF	3.3V Typ.
KIA7021AP/AF	2.1V Typ.	KIA7034AP/AF	3.4V Typ.
KIA7023AP/AF	2.3V Typ.	KIA7035AP/AF	3.5V Typ.
KIA7025AP/AF	2.5V Typ.	KIA7036AP/AF	3.6V Typ.
KIA7027AP/AF	2.7V Typ.	KIA7039AP/AF	3.9V Typ.
KIA7029AP/AF	2.9V Typ.	KIA7042AP/AF	4.2V Typ.
KIA7031AP/AF	3.1V Typ.	KIA7045AP/AF	4.5V Typ.
KIA7032AP/AF	3.2V Typ.		
- Taping Type is also Available.

APPLICATIONS

- (1) As Control Circuit of Battery-Backed Memory.
- (2) As Measure Against Erroneous Operations at Power ON-OFF.
- (3) As Measure Against System Runaway at Instantaneous Break of Power Supply etc.
- (4) As Resetting Function for the CPU-Mounted Equipment, such as Personal Computers, Printers, VTRs and so forth.

EQUIVALENT CIRCUIT

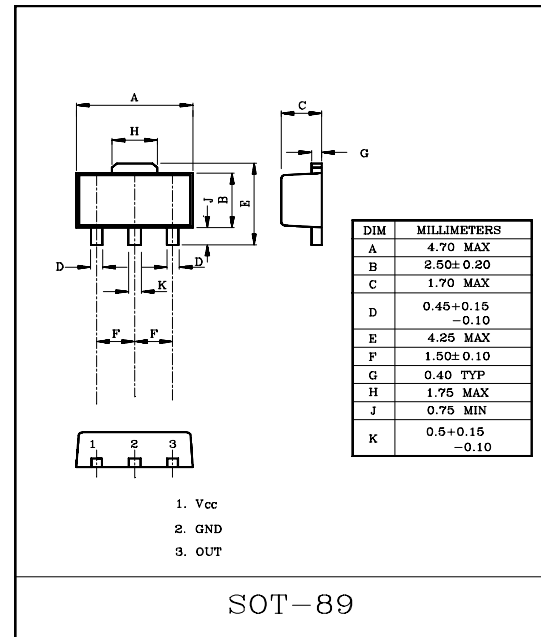
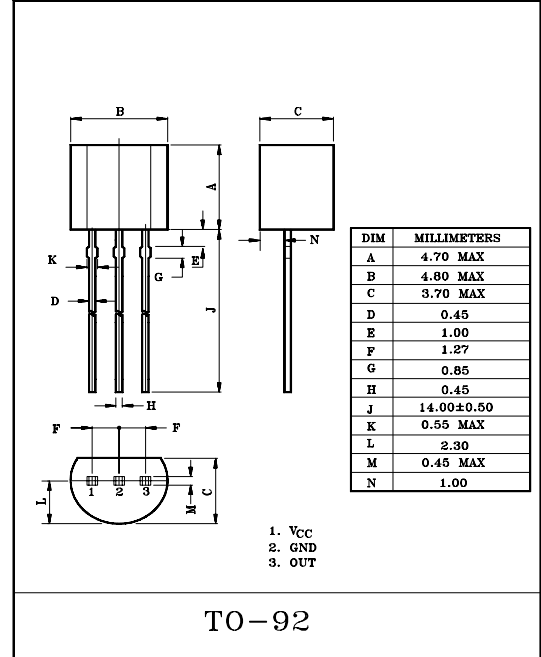
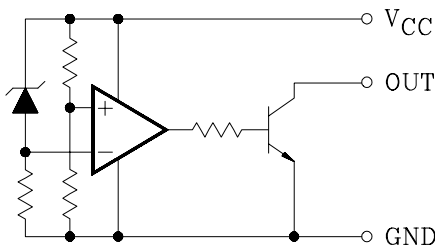

MAXIMUM RATINGS (Ta=25°C)

CHARACTERISTIC	SYMBOL	RATING	UNIT
Supply Voltage	V_{CC}	-0.3~+15.0	V
Power Dissipation (Package Limitation)	KIA7019AP~45AP	400	mW
	KIA7019AF~45AF	500	
Operating Temperature	T_{opr}	-30~+75	°C
Storage Temperature	T_{stg}	-55~+150	°C

MARKING

Type No.	Marking	Type No.	Marking
KIA7019AF	6A	KIA7033AF	6J
KIA7021AF	6B	KIA7034AF	6K
KIA7023AF	6C	KIA7035AF	6L
KIA7025AF	6D	KIA7036AF	6M
KIA7027AF	6E	KIA7039AF	6N
KIA7029AF	6F	KIA7042AF	6P
KIA7031AF	6G	KIA7045AF	6R
KIA7032AF	6H		

KIA7019AP/AF ~ KIA7045AP/AF

ELECTRICAL CHARACTERISTICS

CHARACTERISTIC	SYMBOL	TEST CIR.	TEST CONDITION	MIN.	TYP.	MAX.	UNIT	
Detecting Voltage	V_S	1	$R_L=200\Omega$ $V_{OL}\leq 0.4V$	KIA7019AP/AF	1.75	1.9	2.05	V
				KIA7021AP/AF	1.95	2.1	2.25	
				KIA7023AP/AF	2.15	2.3	2.45	
				KIA7025AP/AF	2.35	2.5	2.65	
				KIA7027AP/AF	2.55	2.7	2.85	
				KIA7029AP/AF	2.75	2.9	3.05	
				KIA7031AP/AF	2.95	3.1	3.25	
				KIA7032AP/AF	3.05	3.2	3.35	
				KIA7033AP/AF	3.15	3.3	3.45	
				KIA7034AP/AF	3.25	3.4	3.55	
				KIA7035AP/AF	3.35	3.5	3.65	
				KIA7036AP/AF	3.45	3.6	3.75	
				KIA7039AP/AF	3.75	3.9	4.05	
				KIA7042AP/AF	4.05	4.2	4.35	
KIA7045AP/AF	4.35	4.5	4.65					
Low-Level Output Voltage	V_{OL}	1	$R_L=200\Omega$	-	-	0.4	V	
Output Leakage Current	I_{OH}	1	$V_{CC}=15V$	-	-	0.1	μA	
Hysteresis Voltage	ΔV_S	1	$R_L=200\Omega$	30	50	100	mV	
Detecting Voltage Temperature Coefficient	$V_S/\Delta T$	1	$R_L=200\Omega$	-	± 0.01	-	%/ $^{\circ}C$	
Circuit Current at on Time	I_{ccL}	1	$V_{CC}=V_{Smin.}-0.05V$	-	300	500	μA	
Circuit Current at off Time	I_{ccH}	1	$V_{CC}=5.25V$	-	30	50	μA	
Threshold Operating Voltage	V_{opr}	1	$R_L=200\Omega$ $V_{OL}\leq 0.4V$	-	0.8	-	V	
"L" Transmission Delay Time	t_{pHL}	2	$R_L=1.0k\Omega$ $C_L=100pF$	-	10	-	μS	
"H" Transmission Delay Time	t_{pLH}	2	$R_L=1.0k\Omega$ $C_L=100pF$	-	15	-	μS	
Output Current at on Time I	$I_{oL I}$	1	$V_{CC}=V_{Smin.}-0.05V$ $T_C=25^{\circ}C$	20	-	-	mA	
Output Current at on Time II	$I_{oL II}$	1	$V_{CC}=V_{Smin.}-0.05V$ $T_C=-30\sim +75^{\circ}C$	16	-	-	mA	

KIA7019AP/AF ~ KIA7045AP/AF

TEST CIRCUIT 1.

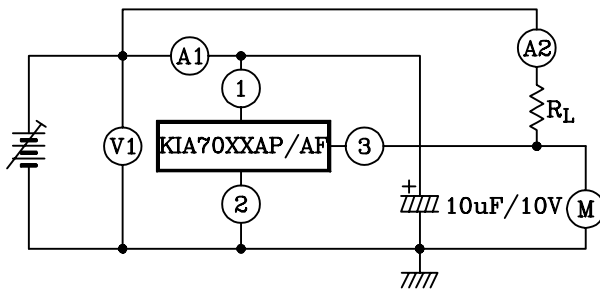

TEST CIRCUIT 2.

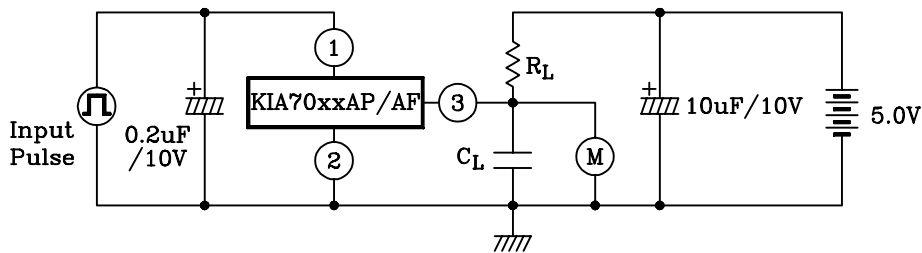

APPLICATION CIRCUIT

(1) BATTERY LOW INDICATOR

(2) CPU RESETING

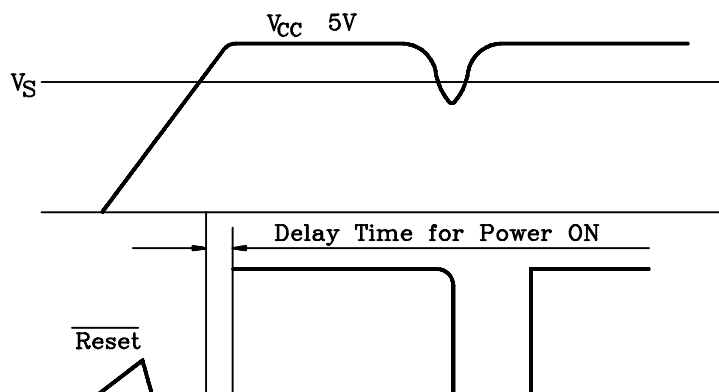
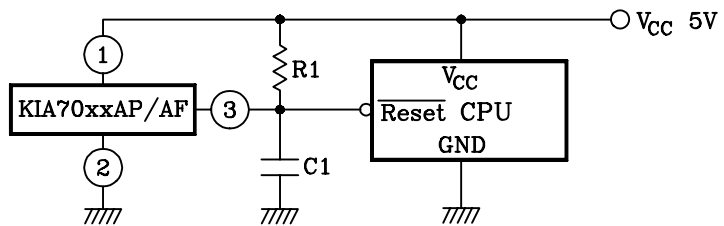
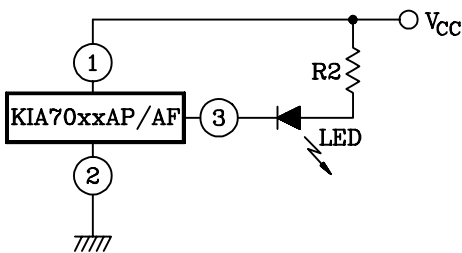

(NOTE)

- (1) Connecting of LED and R2 obtains a voltage drop indicator.
- (2) Connecting of C1 and selection of time constant with C1 and R1 set the power on delay time.

PRECAUTION FOR USE

SOLDERING

Flat Package (SOT-89 Package)

Elements mounting styles of electronic devices are gaining in further diversification over recent years, and needs for components are all the more expanding in varieties. Especially, surface mounting is steadily penetrating into industrial segments as a world-wide popular technical trend. Although exposure to high temperature is inevitable during soldering we recommend limiting the soldering temperature to low levels as shown in figure for the sake of retaining inherent excellent reliability.

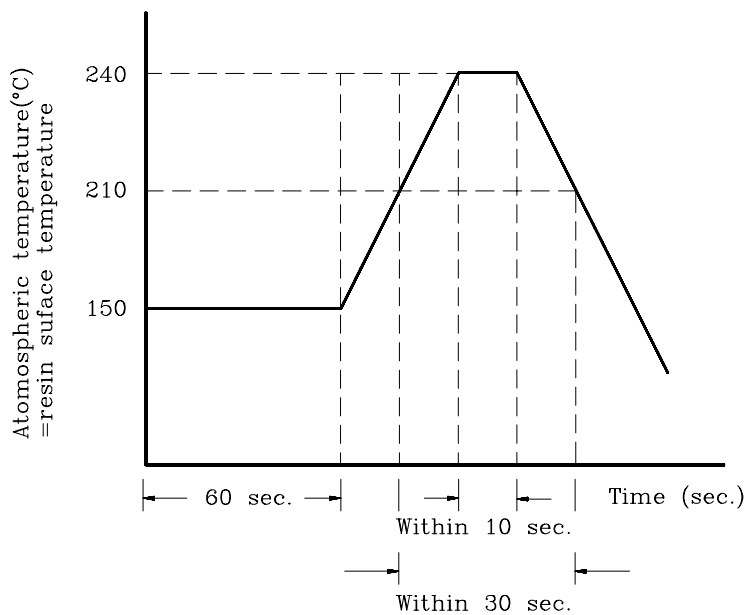

Fig 6

(a) When employing solder reflow method

- ① Atmospheric temperature around resin surfaces must be less than 240°C, not exceeding the time length of 10 sec.
- ② Recommend temperature profile
- ③ Precautions on heating method

When resin is kept exposed to high temperature for a long time, device reliability may be marred. Therefore, it is essential to complete soldering in the shortest time possible to prevent temperature of resin from rising.

(b) When employing halogen lamps or infrared-ray heaters

When halogen lamps or infrared-ray heaters are used, avoid direct irradiation onto resin surfaces; such devices cause extensive localized temperature rise.

※ Please keep a reflow solder operating when SOT-89 package's soldering.