

Prospective data

## Insulated Gate Bi-Polar Transistor Type T1500TA25E

### Absolute Maximum Ratings

	VOLTAGE RATINGS	MAXIMUM LIMITS	UNITS
$V_{CES}$	Collector – emitter voltage	2500	V
$V_{DC\ link}$	Permanent DC voltage for 100 FIT failure rate.	1250	V
$V_{GES}$	Peak gate – emitter voltage	$\pm 20$	V

	RATINGS	MAXIMUM LIMITS	UNITS
$I_{C(DC)}$	Continuous DC collector current, IGBT (Note 2).	2067	A
$I_{CRM}$	Repetitive peak collector current, $t_p=1ms$ , IGBT.	3	kA
$I_{ECO}$	Maximum reverse emitter current, $t_p=1ms$ (note 4).	1500	A
$P_{MAX}$	Maximum power dissipation, IGBT (note 3).	7.5	kW
$T_{j\ op}$	Operating temperature range.	-40 to +125	$^{\circ}C$
$T_{stg}$	Storage temperature range.	-40 to +125	$^{\circ}C$

Notes: -

- 1) Unless otherwise indicated  $T_j = 125^{\circ}C$ .
- 2)  $T_{sink} = 55^{\circ}C$ , double side cooled.
- 3)  $T_{sink} = 25^{\circ}C$ , double side cooled.
- 4) The use of an anti-parallel diode is recommended.

**Characteristics**

IGBT Characteristics

	PARAMETER	MIN	TYP	MAX	TEST CONDITIONS	UNITS
V <sub>CE(sat)</sub>	Collector – emitter saturation voltage	-	2.5	2.9	I <sub>C</sub> = 1500A, V <sub>GE</sub> = 15V, T <sub>J</sub> = 25°C	V
		-	3.0	3.4	I <sub>C</sub> = 1500A, V <sub>GE</sub> = 15V	V
V <sub>T0</sub>	Threshold voltage	-	-	1.8	Current range: 700A – 2000A	V
r <sub>T</sub>	Slope resistance	-	-	0.37		mΩ
V <sub>GE(TH)</sub>	Gate threshold voltage	6	-	9	V <sub>CE</sub> = V <sub>GE</sub> , I <sub>C</sub> = 200mA	V
I <sub>CES</sub>	Collector – emitter cut-off current	-	4	25	V <sub>CE</sub> = V <sub>CES</sub> , V <sub>GE</sub> = 0V	mA
I <sub>GES</sub>	Gate leakage current	-	-	±200	V <sub>GE</sub> = ±20V	μA
C <sub>ies</sub>	Input capacitance	-	200	-	V <sub>CE</sub> = 25V, V <sub>GE</sub> = 0V, f = 1MHz	nF
t <sub>d(on)</sub>	Turn-on delay time	-	2.1	-	I <sub>C</sub> = 1500A, V <sub>CE</sub> = 0.5V <sub>CES</sub> , V <sub>GE</sub> = ±20V, R <sub>g(on)</sub> = 4Ω, R <sub>g(off)</sub> = 8Ω, Snubber : 10Ω and 0.5μF in series	μs
t <sub>r(l)</sub>	Rise time	-	2.8	-		μs
Q <sub>g(on)</sub>	Turn-on gate charge	-	-	29		μC
E <sub>on</sub>	Turn-on energy	-	3.3	-		J
t <sub>d(off)</sub>	Turn-off delay time	-	2.4	-		μs
t <sub>f</sub>	Fall time	-	1.5	-		μs
Q <sub>g(off)</sub>	Turn-off gate charge	-	-	65		μC
E <sub>off</sub>	Turn-off energy	-	1.7	-		J

Other Characteristics

	PARAMETER	MIN	TYP	MAX	TEST CONDITIONS	UNITS
R <sub>thJK</sub>	Thermal resistance junction to sink	-	-	13.2	Double side cooled	K/kW
		-	-	23.1	Collector side cooled	K/kW
		-	-	31.8	Emitter side cooled	K/kW
F	Mounting force	20	-	30		kN
W <sub>t</sub>	Weight	-	1.2	-		kg

Notes:-

- 1) Unless otherwise indicated T<sub>J</sub> = 125°C.

**Curves**

Figure 1 – Typical collector-emitter saturation voltage characteristics

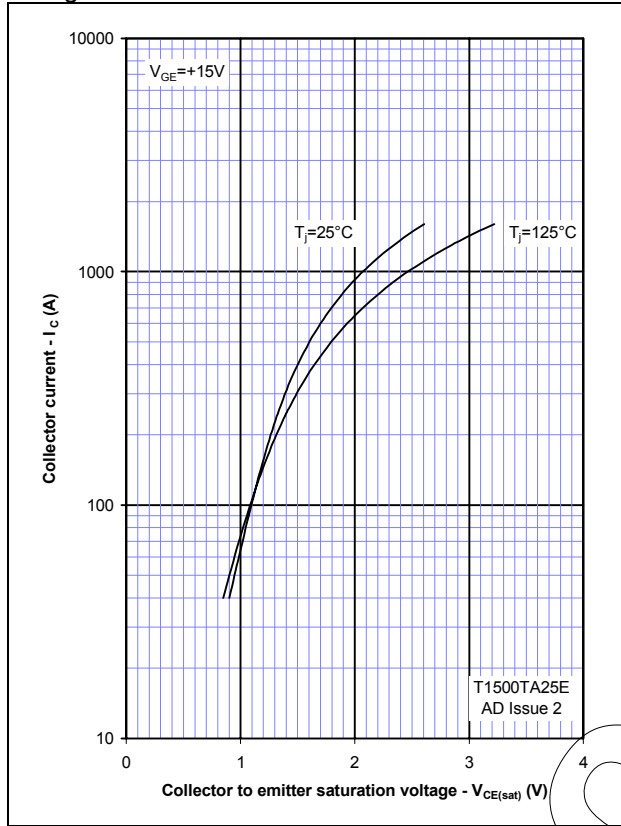

Figure 2 – Typical output characteristic at 25°C

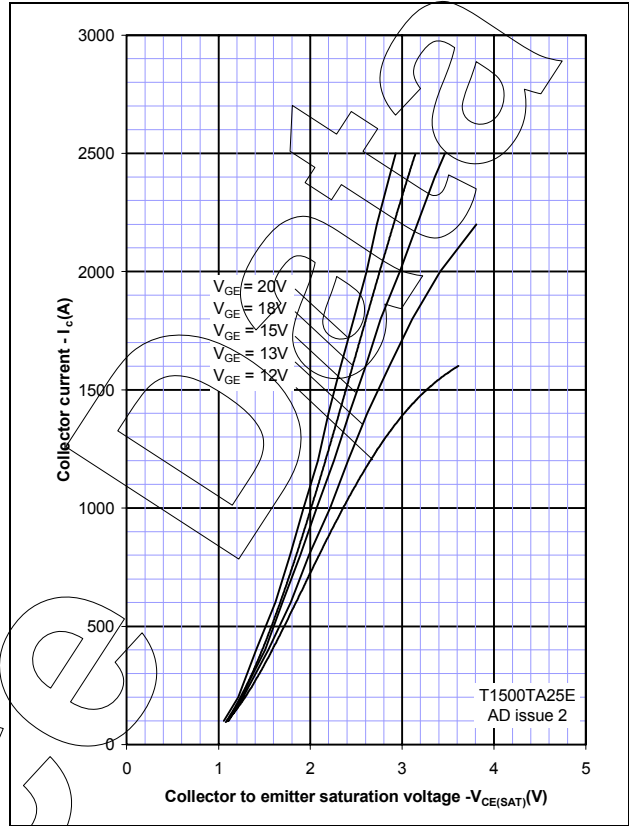

Figure 3 – Typical output characteristic at 125°C

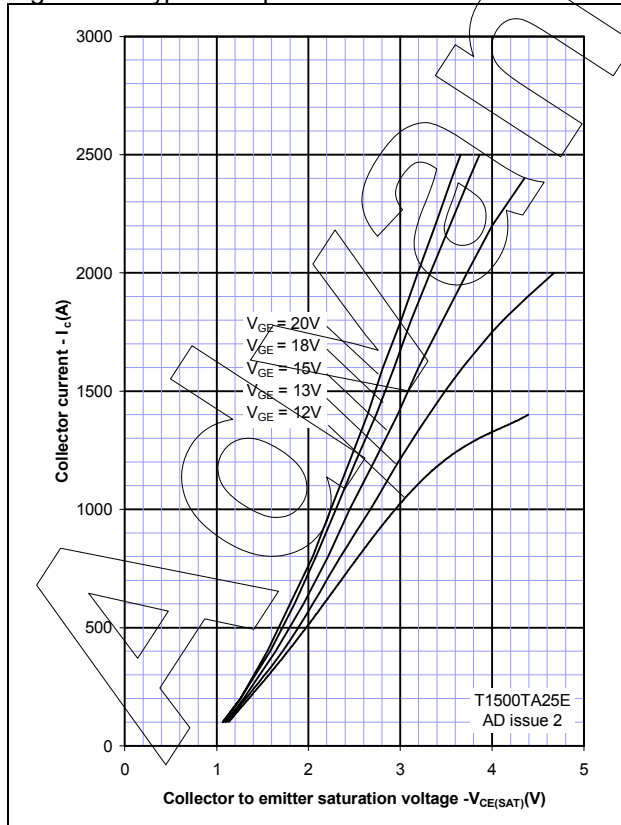

Figure 4 – Typical turn-on gate charge

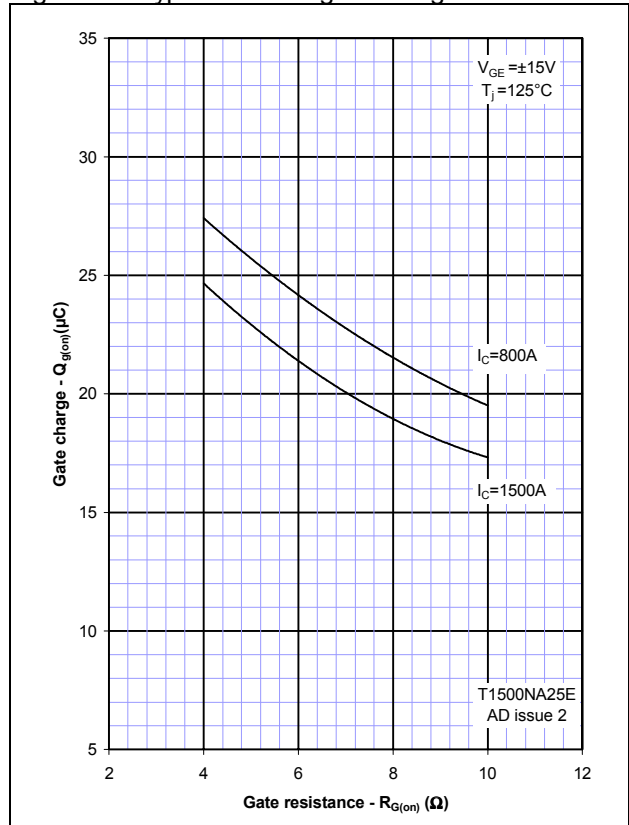

Figure 5 – Typical turn-off gate charge

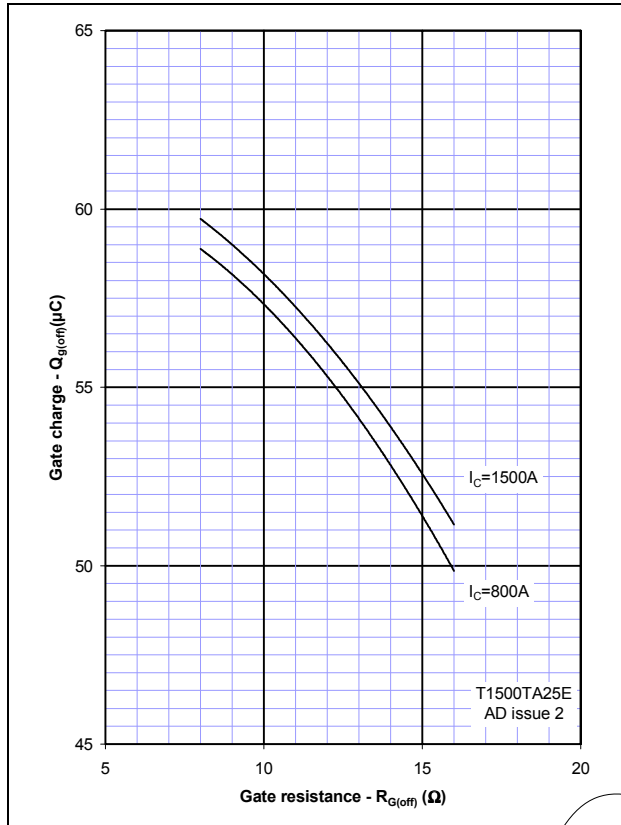

Figure 6 – Typical turn-on delay time vs gate resistance

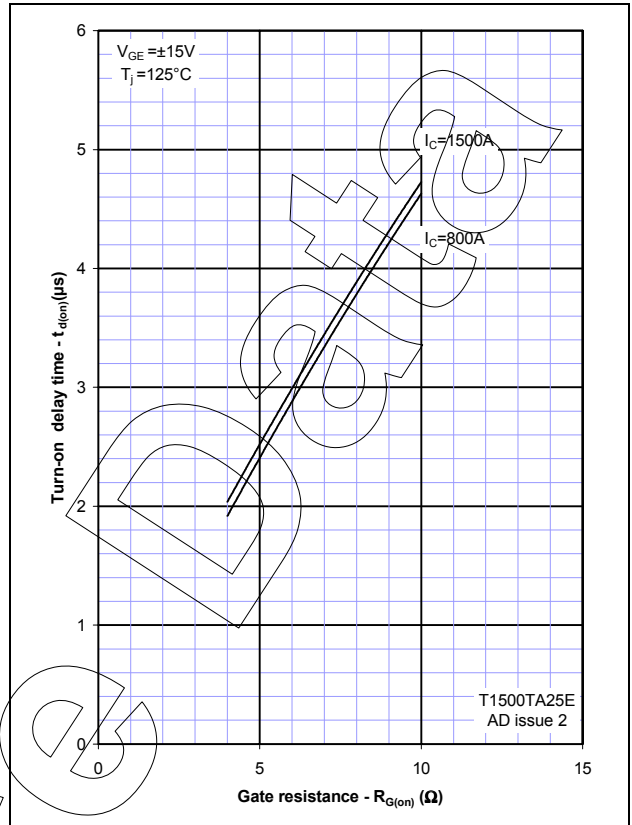

Figure 7 – Typical turn-off delay time vs gate resistance

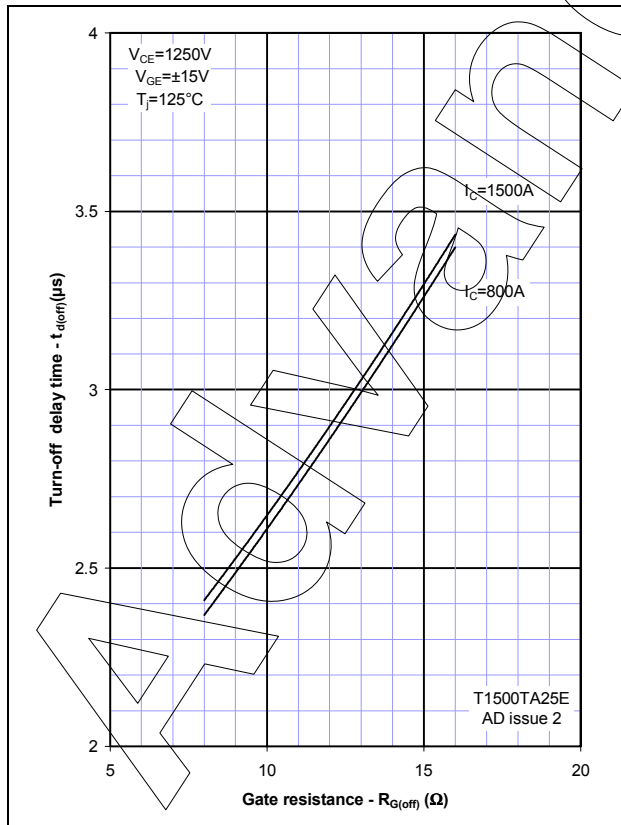

Figure 8 – Typical turn-on energy vs. collector current

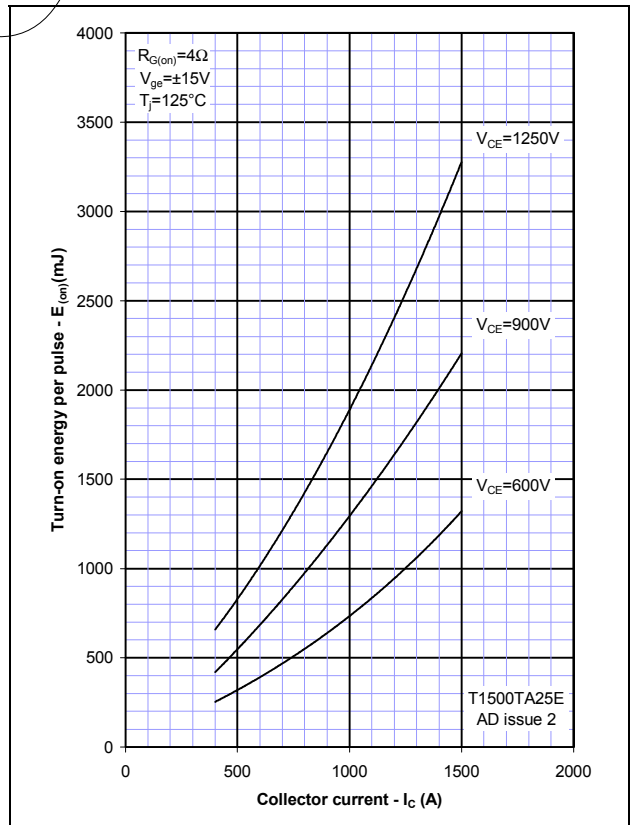

Figure 9 – Typical turn-on energy vs. di/dt

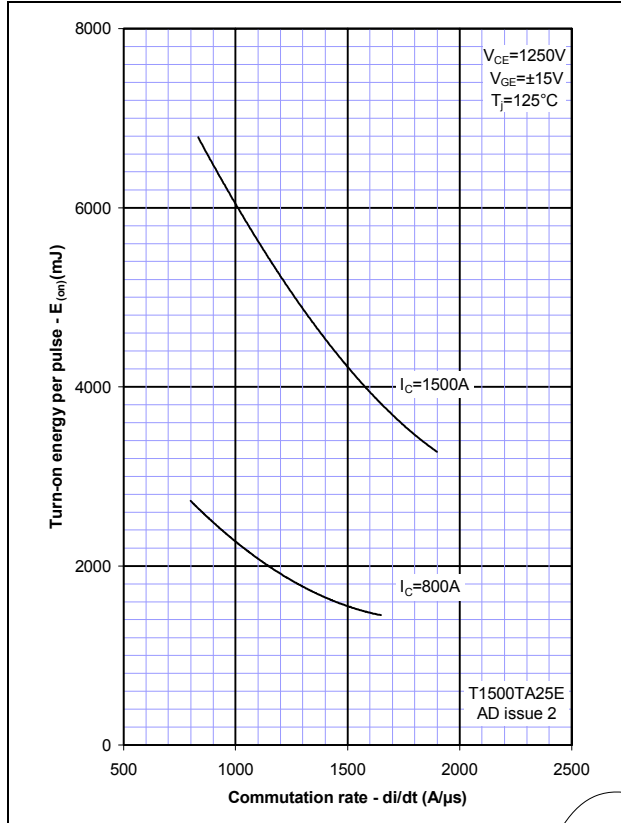

Figure 10 – Typical turn-off energy vs. collector current

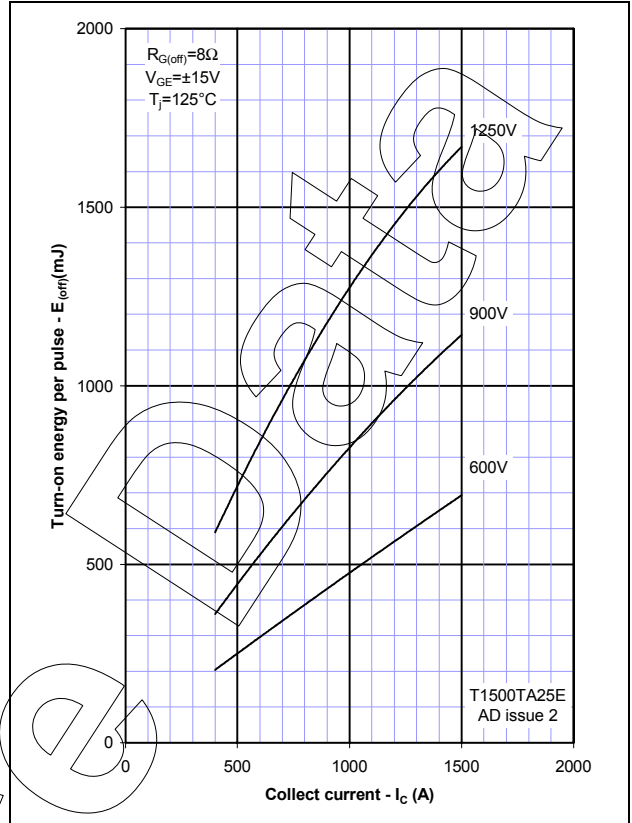

Figure 11 – Turn-off energy vs. voltage

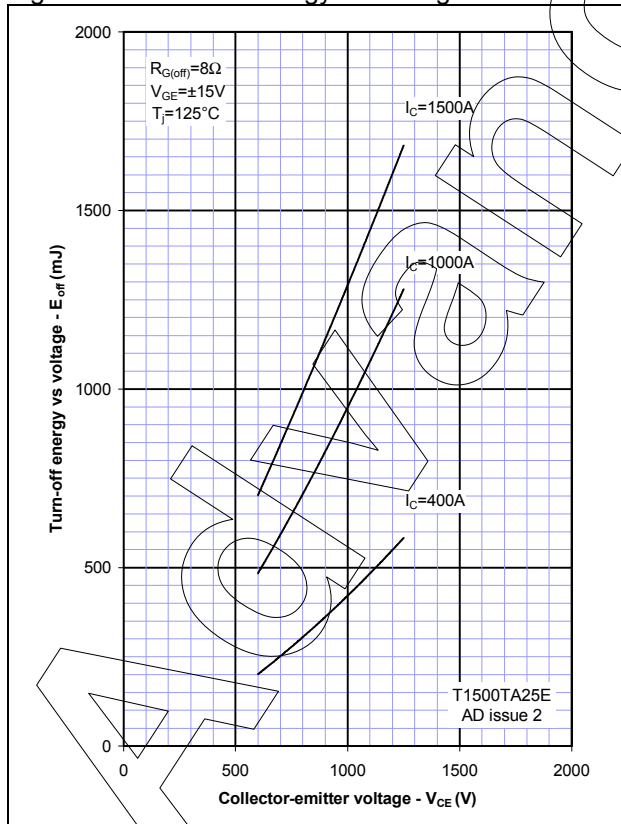

Figure 12 – Safe operating area

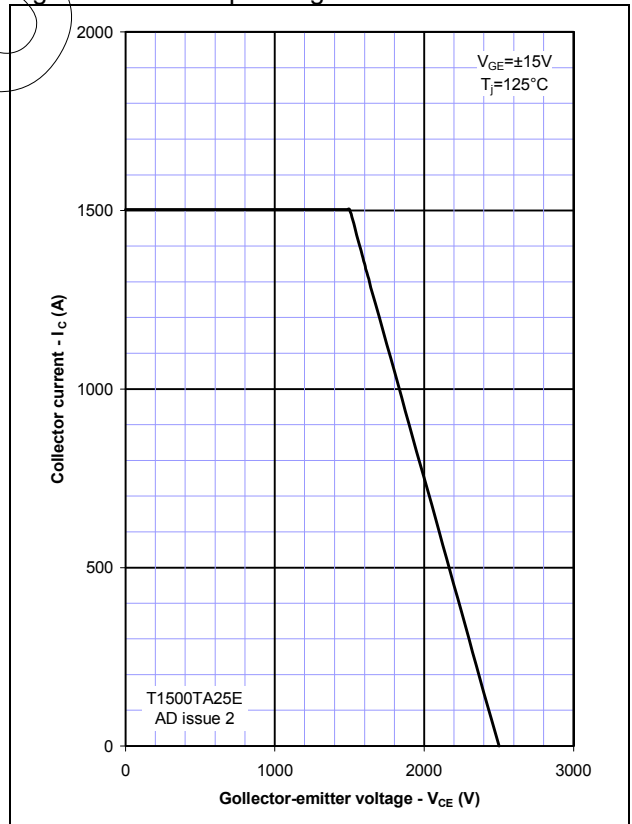
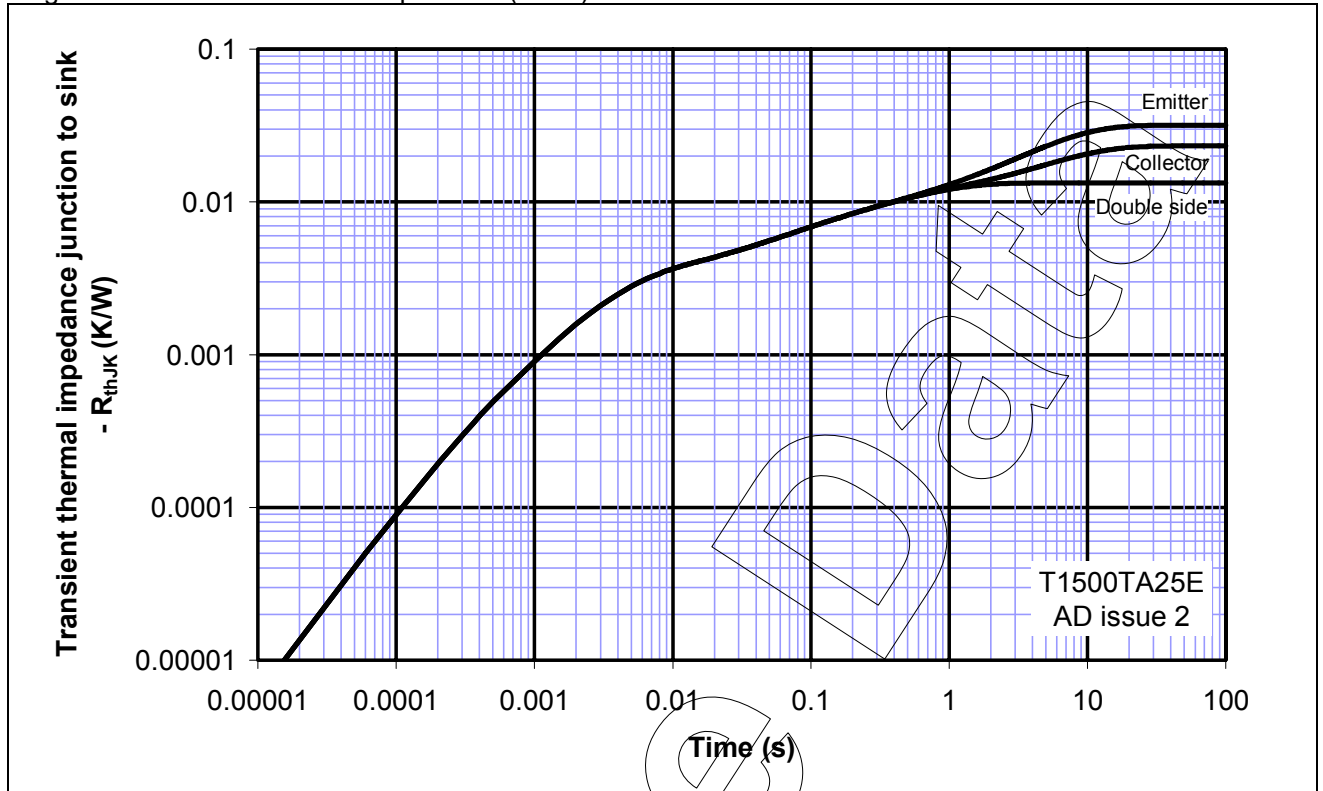
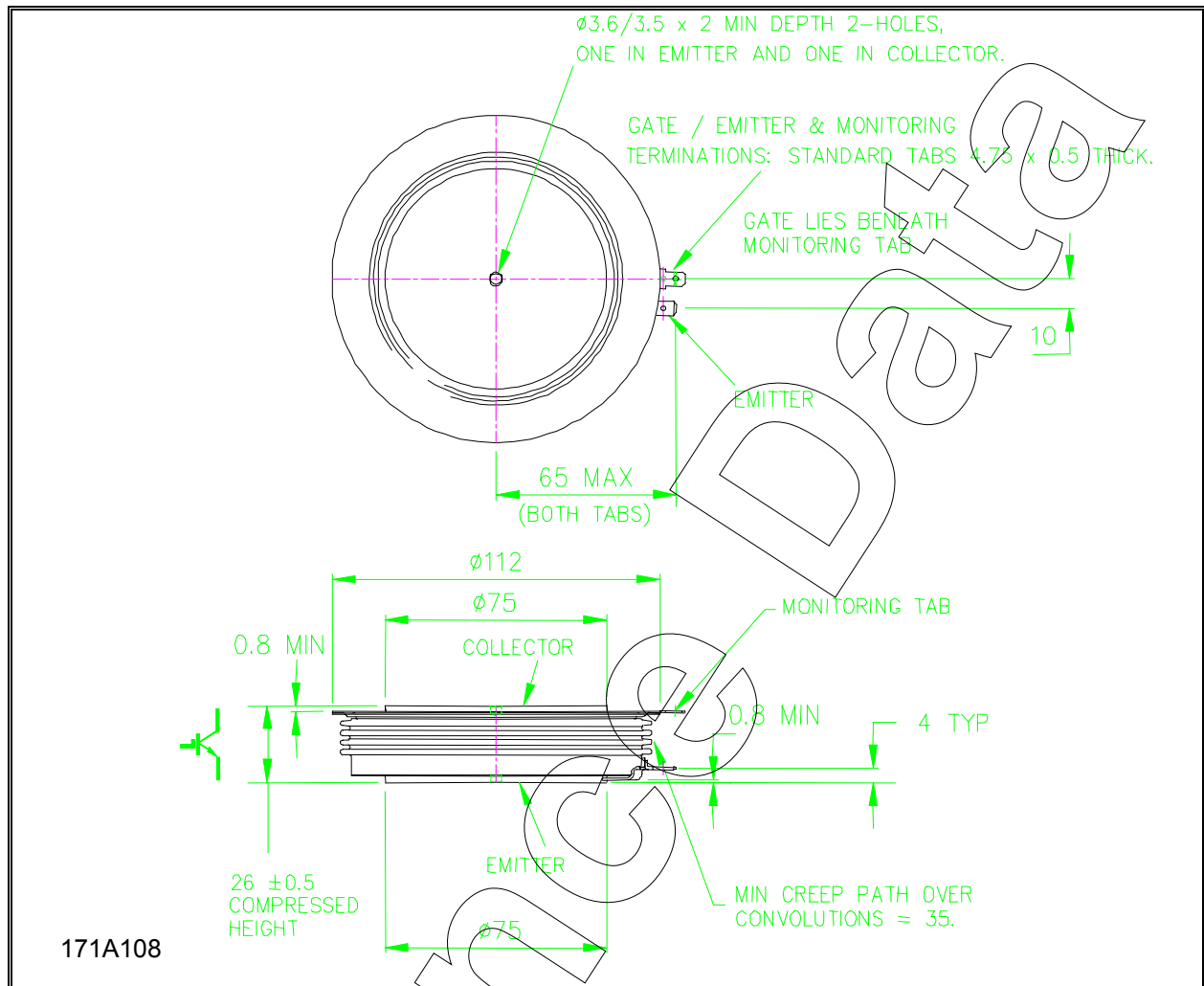

Figure 13– Transient thermal impedance (IGBT)



**Outline Drawing & Ordering Information**



ORDERING INFORMATION			
<b>T1500</b> Fixed Type code	<b>TA</b> Fixed Outline Code	<b>25</b> Voltage Grade 2500V	<b>E</b> Fixed code

(Please quote 10 digit code as below)

Typical order code: T1500TA25E (V<sub>CES</sub> = 2500V)

**IXYS Semiconductor GmbH**  
Edisonstraße 15  
D-68623 Lamertheim  
Tel: +49 6206 503-0  
Fax: +49 6206 503-627  
E-mail: [marcom@ixys.de](mailto:marcom@ixys.de)

**WESTCODE**  
An IXYS Company

**Westcode Semiconductors Ltd**  
Langley Park Way, Langley Park,  
Chippenham, Wiltshire, SN15 1GE.  
Tel: +44 (0)1249 444524  
Fax: +44 (0)1249 659448  
E-mail: [WSL.sales@westcode.com](mailto:WSL.sales@westcode.com)

**IXYS Corporation**  
3540 Bassett Street  
Santa Clara CA 95054 USA  
Tel: +1 (408) 982 0700  
Fax: +1 (408) 496 0670  
E-mail: [sales@ixys.net](mailto:sales@ixys.net)

[www.westcode.com](http://www.westcode.com)

[www.ixys.net](http://www.ixys.net)

**Westcode Semiconductors Inc**  
3270 Cherry Avenue  
Long Beach CA 90807 USA  
Tel: +1 (562) 595 6971  
Fax: +1 (562) 595 8182  
E-mail: [WSI.sales@westcode.com](mailto:WSI.sales@westcode.com)

The information contained herein is confidential and is protected by Copyright. The information may not be used or disclosed except with the written permission of and in the manner permitted by the proprietors Westcode Semiconductors Ltd. © Westcode Semiconductors Ltd.

In the interest of product improvement, Westcode reserves the right to change specifications at any time without prior notice.

Devices with a suffix code (2-letter or letter/digit/letter combination) added to their generic code are not necessarily subject to the conditions and limits contained in this report.