

Provisional data

Insulated Gate Bi-Polar Transistor Type T0500NA25E

(Development Type Number: TX044NA25E)

Absolute Maximum Ratings

	VOLTAGE RATINGS	MAXIMUM LIMITS	UNITS
V_{CES}	Collector – emitter voltage	2500	V
$V_{DC\ link}$	Permanent DC voltage for FIT failure rate.	1250	V
V_{GES}	Peak gate – emitter voltage	±20	V

	RATINGS	MAXIMUM LIMITS	UNITS
$I_{C(DC)}$	Continuous DC collector current, IGBT (Note 2).	605	A
I_{CRM}	Repetitive peak collector current, $t_p=1ms$, IGBT.	1000	A
I_{ECO}	Maximum reverse emitter current, $t_p=1ms$ (note 4).	500	A
P_{MAX}	Maximum power dissipation, IGBT (note 3).	2.6	kW
T_j	Operating temperature range.	-40 to +125	°C
T_{stg}	Storage temperature range.	-40 to +125	°C

Notes: -

- 1) Unless otherwise indicated $T_j = 125^\circ\text{C}$.
- 2) $T_{sink} = 55^\circ\text{C}$, double side cooled.
- 3) $T_{sink} = 25^\circ\text{C}$, double side cooled.
- 4) The use of an anti-parallel diode is recommended.

Characteristics

IGBT Characteristics

	PARAMETER	MIN	TYP	MAX	TEST CONDITIONS	UNITS
V _{CE(sat)}	Collector – emitter saturation voltage	-	2.4	2.7	I _C = 500A, V _{GE} = 15V, T _j = 25°C	V
		-	2.75	3.3	I _C = 500A, V _{GE} = 15V	V
V _{To}	Threshold voltage	-	-	1.57	Current range: 300 – 650A	V
r _T	Slope resistance	-	-	2.35		mΩ
V _{ECO}	Reverse avalanche voltage	-	22	-	I _{ECO} = 200A	V
V _{GE(TH)}	Gate threshold voltage	6	7.5	9	V _{CE} = V _{GE} , I _C = 200mA	V
I _{CES}	Collector – emitter cut-off current	-	2	7	V _{CE} = V _{CES} , V _{GE} = 0V	mA
I _{GES}	Gate leakage current	-	-	±3.5	V _{GE} = ±20V	μA
C _{ies}	Input capacitance	-	82	-	V _{CE} = 25V, V _{GE} = 0V, f = 1MHz	nF
t _{d(on)}	Turn-on delay time	-	2.3	-	I _C = 500A, V _{CE} = 0.5V _{CES} , V _{GE} = ±20V, R _{g(ON)} = 20Ω, R _{g(OFF)} = 15Ω, Snubber : 10Ω and 0.22μF in series	μs
t _{r(l)}	Rise time	-	2.0	-		μs
Q _{g(on)}	Turn-on gate charge	-	-	15		μC
E _{on}	Turn-on energy	-	0.8	-		J
t _{d(off)}	Turn-off delay time	-	1.6	-		μs
t _f	Fall time	-	2.5	-		μs
Q _{g(off)}	Turn-off gate charge	-	-	38		μC
E _{off}	Turn-off energy	-	0.5	-		J

Thermal Characteristics

	PARAMETER	MIN	TYP	MAX	TEST CONDITIONS	UNITS
R _{th(j-hs)}	Thermal impedance junction to sink, IGBT	-	-	38.6	Double side cooled	K/kW
		-	-	58.6	Collector side cooled	K/kW
		-	-	112	Emitter side cooled	K/kW
F	Mounting force	8	-	12		kN
W _t	Weight	-	0.5	-		kg

Notes:-

- 1) Unless otherwise indicated T_j = 125°C.

Curves

Figure 1 – Typical and maximum collector-emitter saturation voltage characteristics

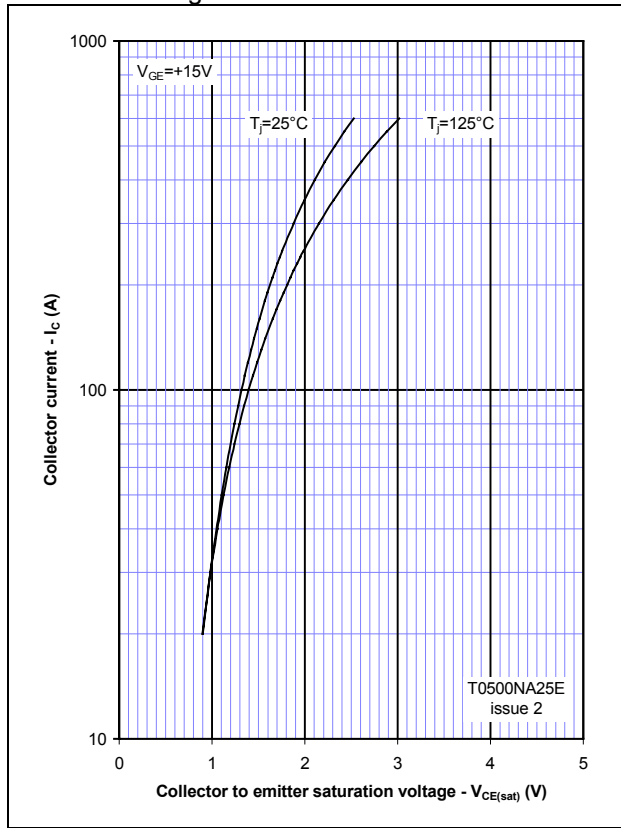

Figure 2 – Typical output characteristic at 25°C

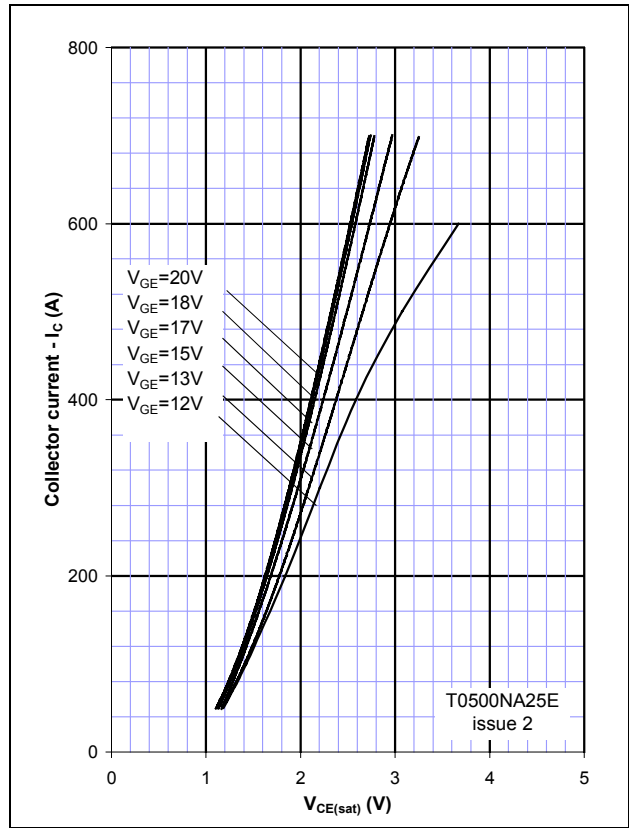

Figure 3 – Typical output characteristic at 125°C

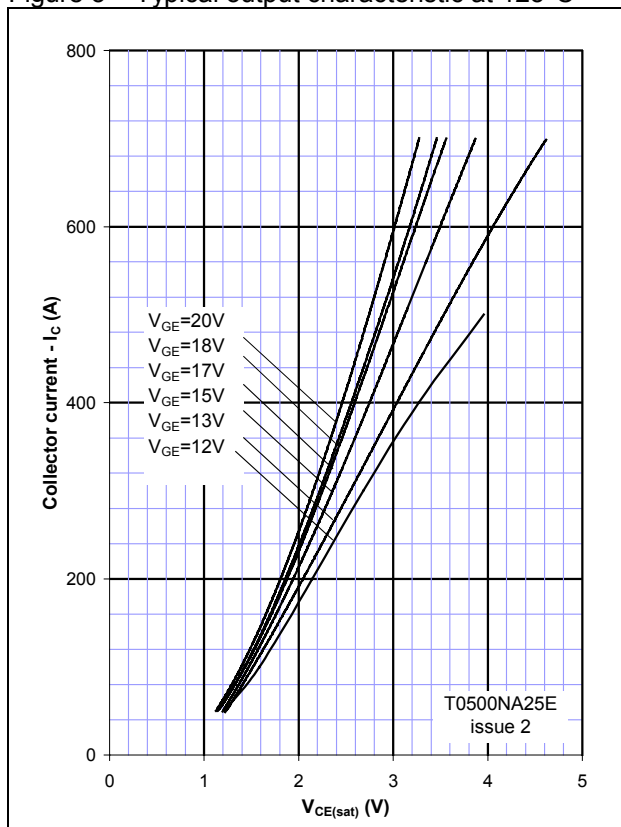

Figure 4 – Typical turn-on gate charge

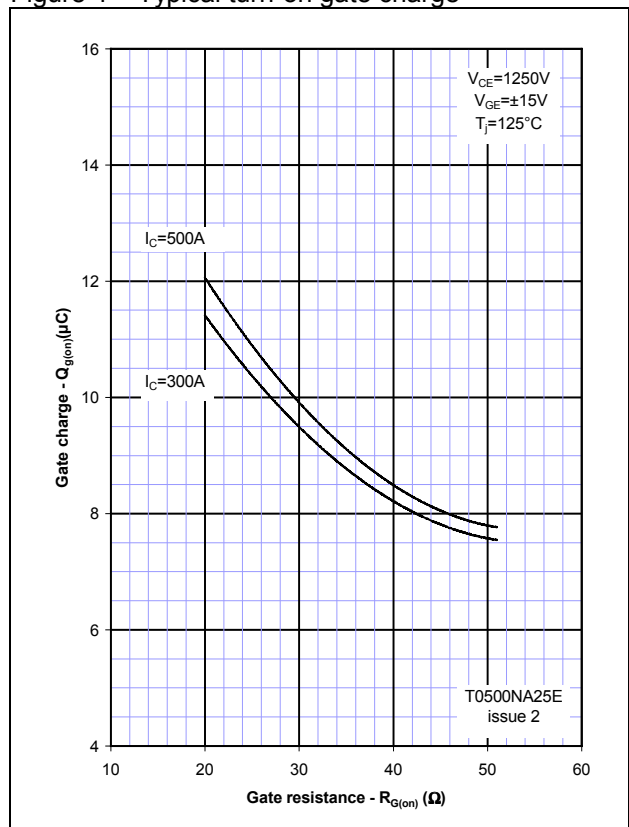

Figure 5 – Typical turn-off gate charge

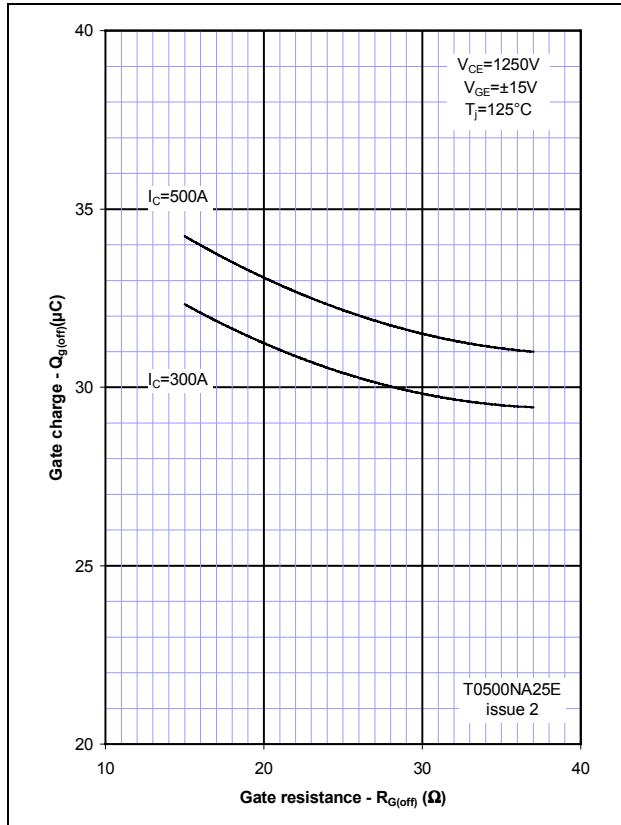

Figure 6 – Typical turn-on delay time vs gate resistance

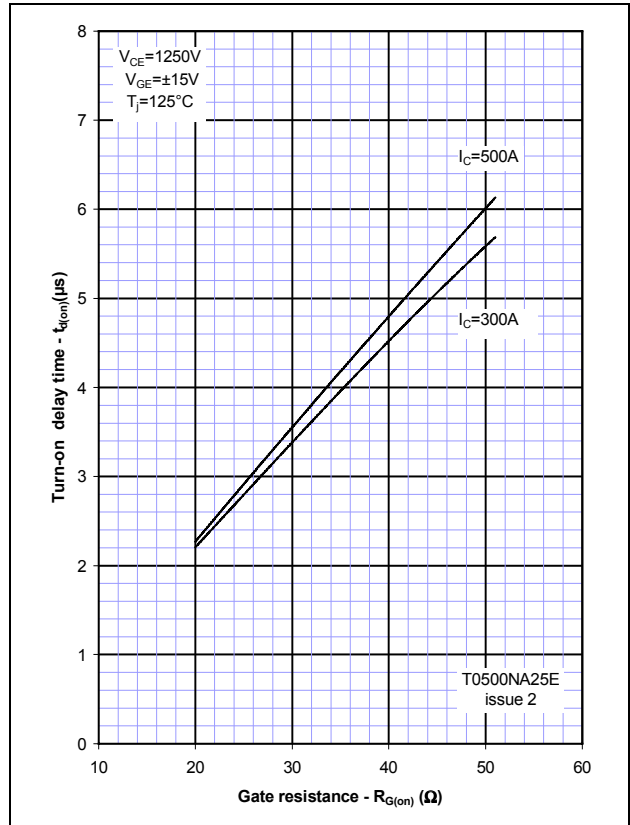

Figure 7 – Typical turn-off delay time vs. gate resistance

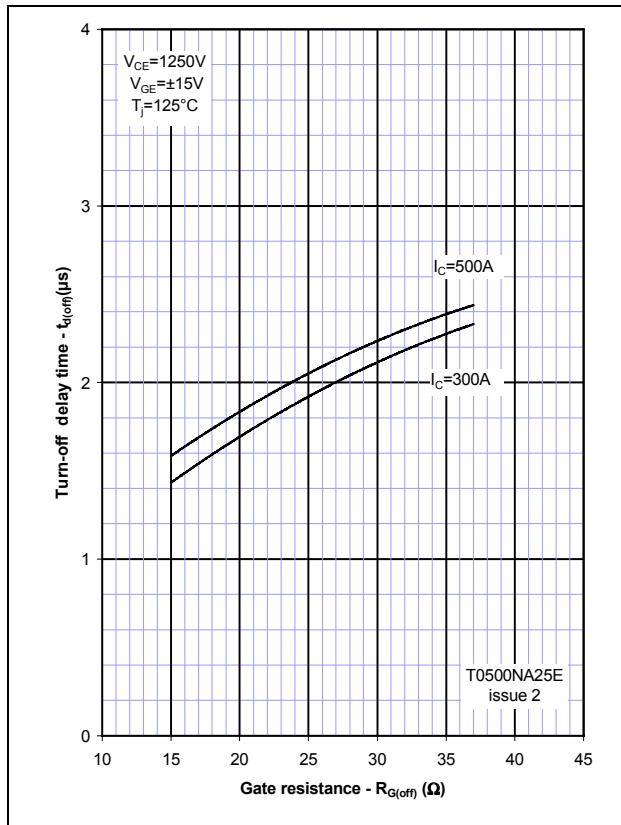

Figure 8 – Typical turn-on energy vs. collector current

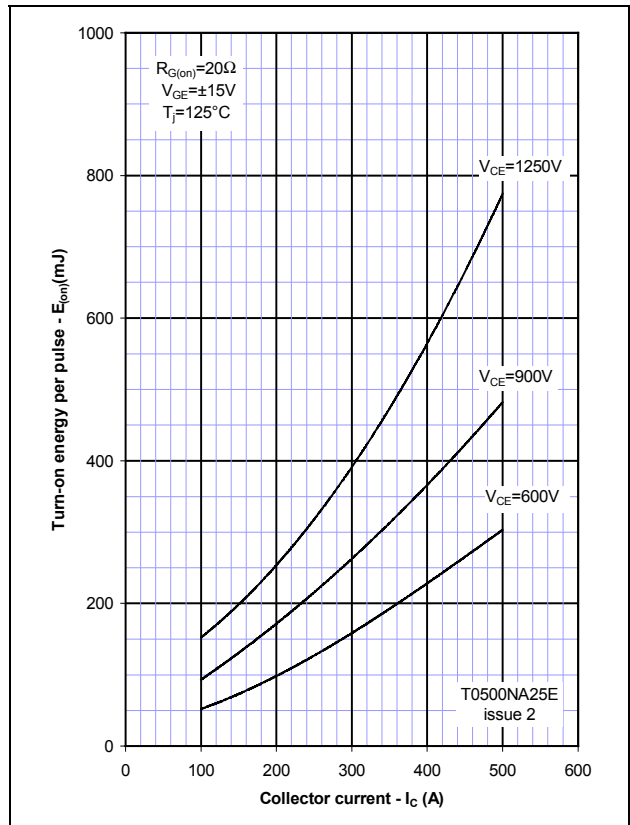

Figure 9 – Typical turn-on energy vs. di/dt

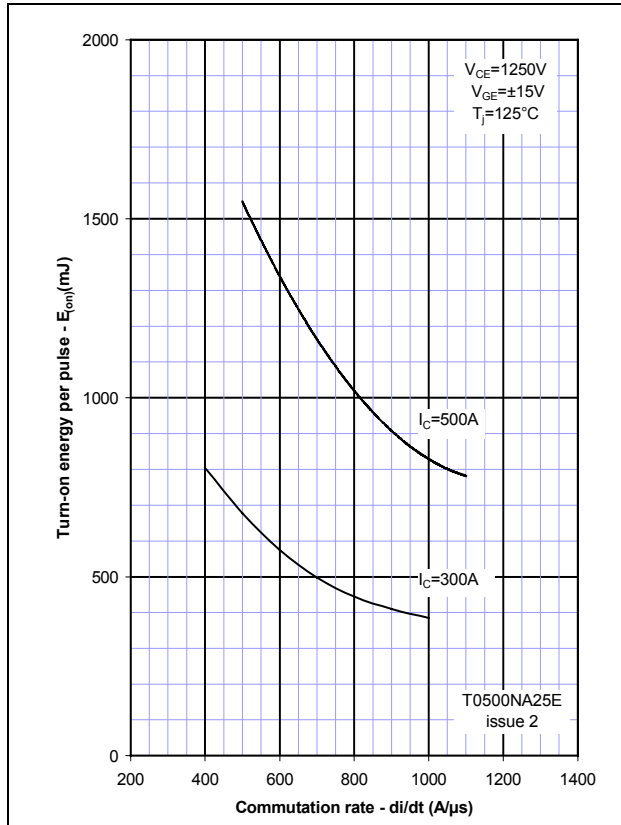

Figure 10 – Typical turn-off energy vs. collector current

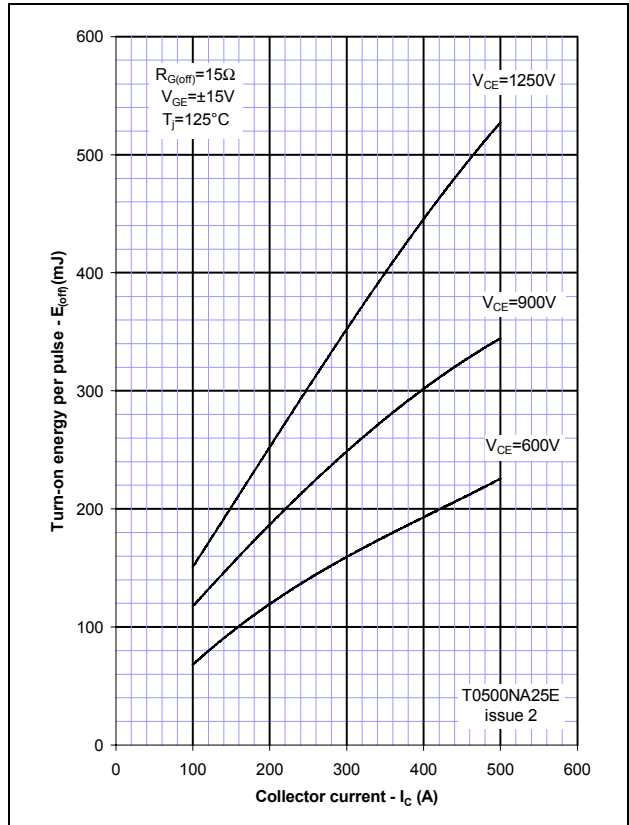

Figure 11 – Turn-off energy vs voltage

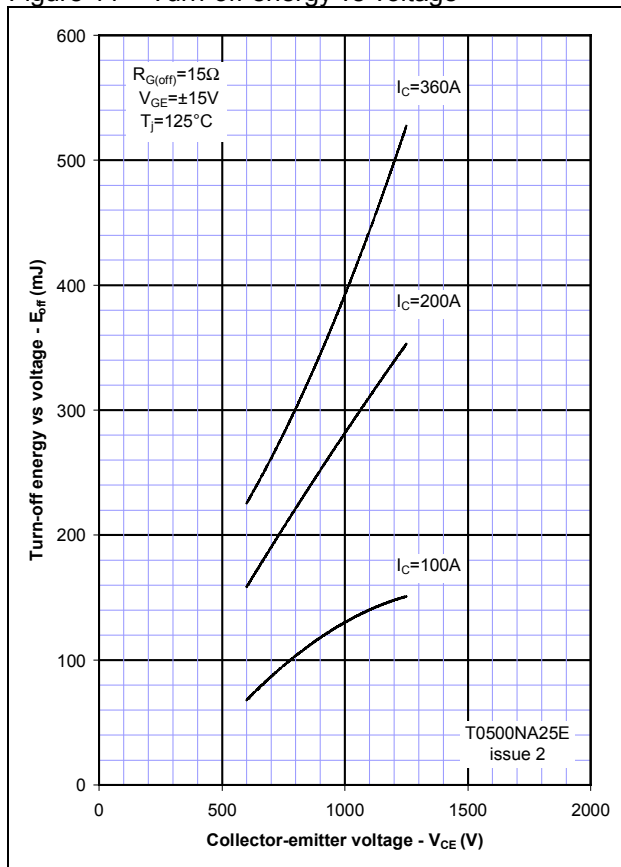

Figure 12 – Safe operating area

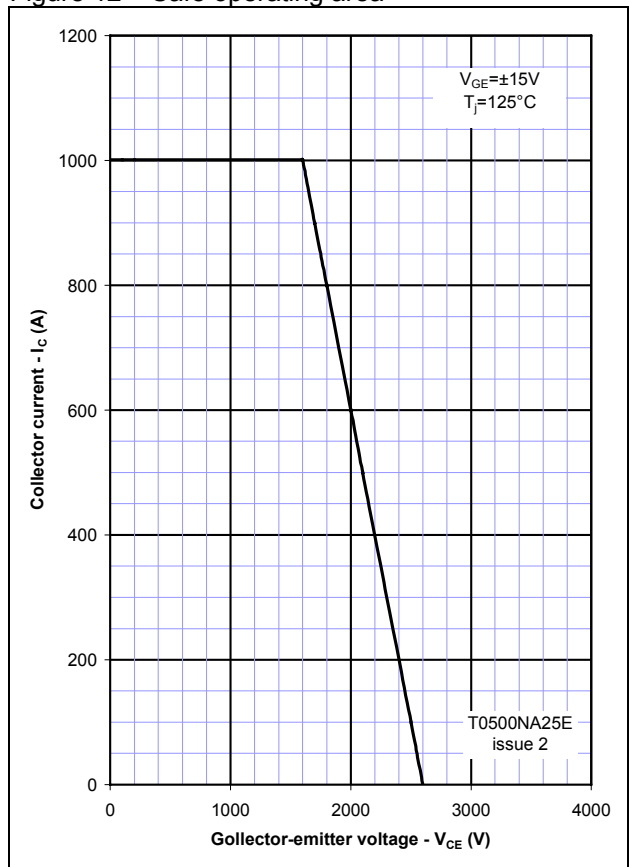
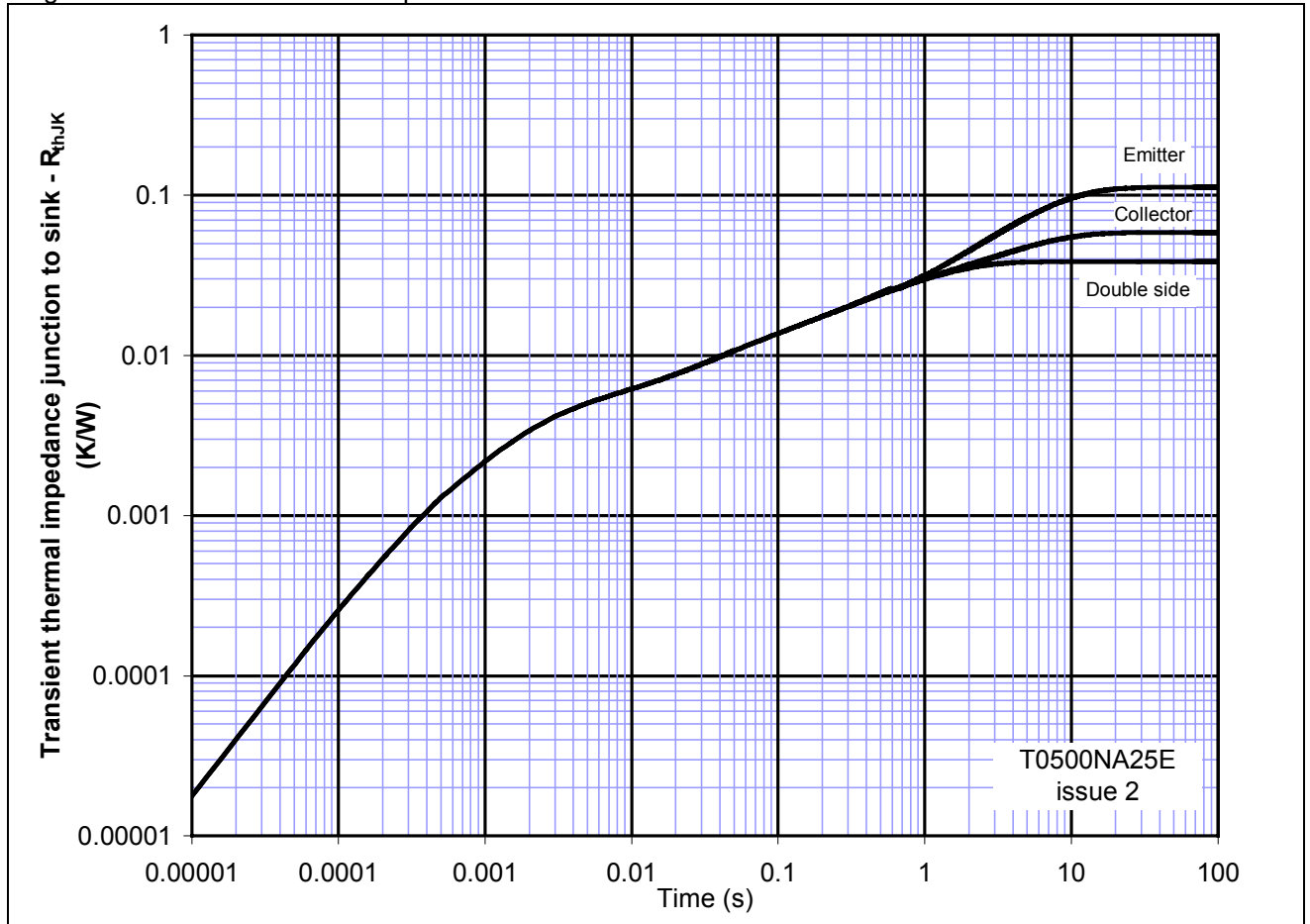
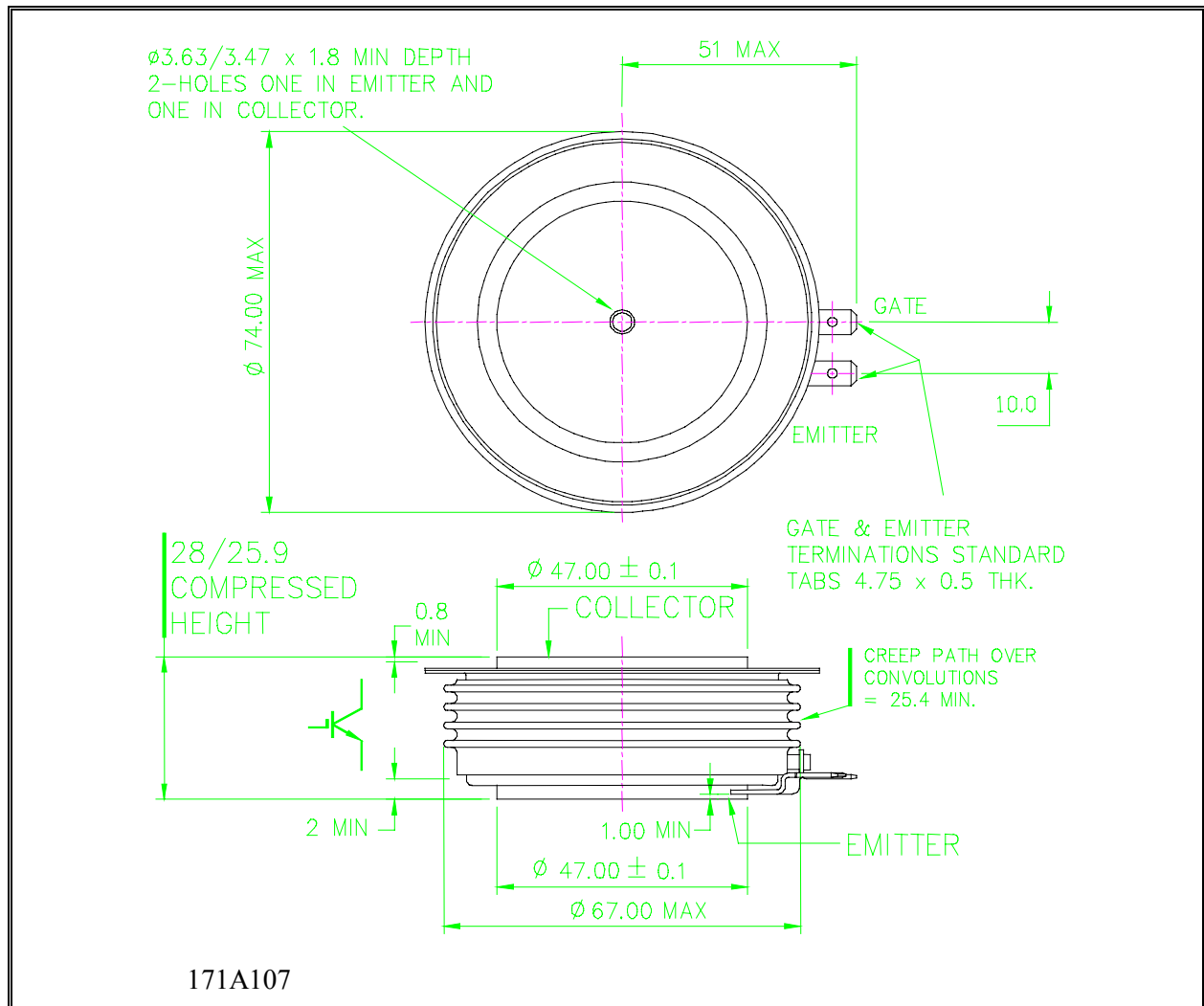

Figure 13 – Transient thermal impedance



Outline Drawing & Ordering Information



ORDERING INFORMATION			
(Please quote 10 digit code as below)			
T0500	NA	25	E
Fixed type code	Fixed Outline Code	Voltage Grade 2500V	Fixed format code

Typical order code: T0500NA25E (V_{CES} = 2500V)

IXYS Semiconductor GmbH
 Edisonstraße 15
 D-68623 Lampertheim
 Tel: +49 6206 503-0
 Fax: +49 6206 503-627
 E-mail: marcom@ixys.de

WESTCODE
 An IXYS Company

Westcode Semiconductors Ltd
 Langley Park Way, Langley Park,
 Chippenham, Wiltshire, SN15 1GE.
 Tel: +44 (0)1249 444524
 Fax: +44 (0)1249 659448
 E-mail: WSL.sales@westcode.com

IXYS Corporation
 3540 Bassett Street
 Santa Clara CA 95054 USA
 Tel: +1 (408) 982 0700
 Fax: +1 (408) 496 0670
 E-mail: sales@ixys.net

www.westcode.com

www.ixys.net

Westcode Semiconductors Inc
 3270 Cherry Avenue
 Long Beach CA 90807 USA
 Tel: +1 (562) 595 6971
 Fax: +1 (562) 595 8182
 E-mail: WSI.sales@westcode.com

The information contained herein is confidential and is protected by Copyright. The information may not be used or disclosed except with the written permission of and in the manner permitted by the proprietors Westcode Semiconductors Ltd.

© Westcode Semiconductors Ltd.

In the interest of product improvement, Westcode reserves the right to change specifications at any time without prior notice.

Devices with a suffix code (2-letter or letter/digit/letter combination) added to their generic code are not necessarily subject to the conditions and limits contained in this report.