

CoolMOS™ Power MOSFET IXKC 40N60C

in ISOPLUS220™ Package

Electrically Isolated Back Surface

Low $R_{DS(on)}$, High Voltage, CoolMOS™ Superjunction MOSFET

Preliminary Data Sheet

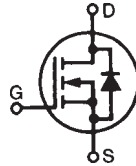

$$V_{DSS} = 600 \text{ V}$$

$$I_{D25} = 24 \text{ A}$$

$$R_{DS(on)} = 96 \text{ m}\Omega$$

Symbol	Test Conditions	Maximum Ratings	
V_{DSS}	$T_J = 25^\circ\text{C}$ to 150°C	600	V
V_{GS}	Continuous	± 20	V
I_{D25}	$T_C = 25^\circ\text{C}$; Note 1	24	A
I_{D90}	$T_C = 90^\circ\text{C}$; Note 1	17	A
$I_{D(RMS)}$	Package lead current limit	45	A
E_{AS}	$I_o = 10\text{A}$, $T_C = 25^\circ\text{C}$	690	mJ
E_{AR}	$I_o = 20\text{A}$	1	mJ
P_D	$T_C = 25^\circ\text{C}$	160	W
T_J		-55 ... +150	$^\circ\text{C}$
T_{JM}		150	$^\circ\text{C}$
T_{stg}		-55 ... +125	$^\circ\text{C}$
T_L	1.6 mm (0.062 in.) from case for 10 s	300	$^\circ\text{C}$
V_{ISOL}	RMS leads-to-tab, 50/60 Hz, $t = 1$ minute	2500	V~
F_C	Mounting force	11 ... 65 / 2.4 ... 11	N/lb
Weight		3	g

ISOPLUS220™
E153432

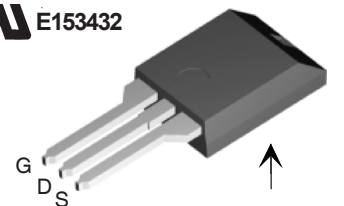

Isolated back surface*

G = Gate, D = Drain,
S = Source

* Patent pending

Features

- Silicon chip on Direct-Copper-Bond substrate
 - High power dissipation
 - Isolated mounting surface
 - 2500V electrical isolation
- 3rd generation CoolMOS™ power MOSFET
 - High blocking capability
 - Low on resistance
 - Avalanche rated for unclamped inductive switching (UIS)
- Low thermal resistance due to reduced chip thickness
- Low drain to tab capacitance (<30pF)

Applications

- Switched Mode Power Supplies (SMPS)
- Uninterruptible Power Supplies (UPS)
- Power Factor Correction (PFC)
- Welding
- Inductive Heating

Advantages

- Easy assembly: no screws or isolation foils required
- Space savings
- High power density

Symbol	Test Conditions	Characteristic Values ($T_J = 25^\circ\text{C}$, unless otherwise specified)		
		min.	typ.	max.
$R_{DS(on)}$	$V_{GS} = 10 \text{ V}$, $I_D = 28 \text{ A}$, Note 3 $V_{GS} = 10 \text{ V}$, $I_D = 28 \text{ A}$, Note 3, $T_J = 125^\circ\text{C}$		80 230	96 mΩ mΩ
$V_{GS(th)}$	$V_{DS} = V_{GS}$, $I_D = 2 \text{ mA}$	2.5		5.5 V
I_{DSS}	$V_{DS} = V_{DSS}$, $T_J = 25^\circ\text{C}$ $V_{GS} = 0 \text{ V}$, $T_J = 125^\circ\text{C}$		20	2 μA μA
I_{GSS}	$V_{GS} = \pm 20 V_{DC}$, $V_{DS} = 0$			± 200 nA

CoolMOS is a trademark of Infineon Technologies, AG

Symbol	Test Conditions	Characteristic Values ($T_J = 25^\circ\text{C}$, unless otherwise specified)		
		min.	typ.	max.
$Q_{g(\text{on})}$	$V_{GS} = 10\text{ V}, V_{DS} = 350\text{ V}, I_D = 40\text{ A}$		158	nC
Q_{gs}			42	nC
Q_{gd}			92	nC
$t_{d(\text{on})}$	$V_{GS} = 10\text{ V}, V_{DS} = 380\text{ V}$ $I_D = 40\text{ A}, R_G = 1.8\ \Omega$		20	ns
t_r			55	ns
$t_{d(\text{off})}$			60	ns
t_f			10	ns
R_{thJC}				0.5 K/W
R_{thCH}		0.30		K/W

Reverse Correction		Characteristic Values ($T_J = 25^\circ\text{C}$, unless otherwise specified)		
Symbol	Test Conditions	min.	typ.	max.
V_{SD}	$I_F = 20\text{ A}, V_{GS} = 0\text{ V}$ Note 3		0.8	1.2 V

Note: 1. MOSFET chip capability
 2. Intrinsic diode capability
 3. Pulse test, $t \leq 300\ \mu\text{s}$, duty cycle $d \leq 2\%$

ISOPLUS 220LV Outline

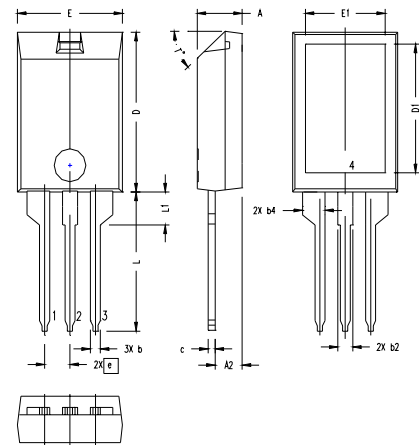

SYM	INCHES		MILLIMETERS	
	MIN	MAX	MIN	MAX
A	.157	.197	4.00	5.00
A2	.098	.118	2.50	3.00
b	.035	.051	0.90	1.30
b2	.049	.065	1.25	1.65
b4	.093	.100	2.35	2.55
c	.028	.039	0.70	1.00
D	.591	.630	15.00	16.00
D1	.472	.512	12.00	13.00
E	.394	.433	10.00	11.00
E1	.295	.335	7.50	8.50
e	.100 BASIC		2.55 BASIC	
L	.512	.571	13.00	14.50
L1	.118	.138	3.00	3.50
T*			42.5*	47.5*

Notes:

- Lead 1 = Gate
- Lead 2 = Drain
- Lead 3 = Source
- Back surface 4 is electrically isolated from leads 1, 2 & 3

IXYS reserves the right to change limits, test conditions, and dimensions.

IXYS MOSFETs and IGBTs are covered by one or more of the following U.S. patents:	4,835,592	4,931,844	5,049,961	5,237,481	6,162,665	6,404,065 B1	6,683,344	6,727,585
	4,850,072	5,017,508	5,063,307	5,381,025	6,259,123 B1	6,534,343	6,710,405B2	6,759,692
	4,881,106	5,034,796	5,187,117	5,486,715	6,306,728 B1	6,583,505	6,710,463	