

**HiPerFAST™ IGBT
B2-Class High Speed IGBT**
IXGH 16N60B2D1

$$\begin{aligned}
 V_{CES} &= 600 \text{ V} \\
 I_{C25} &= 40 \text{ A} \\
 V_{CE(sat)} &= 2.0 \text{ V} \\
 t_{fi(typ)} &= 80 \text{ ns}
 \end{aligned}$$

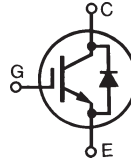
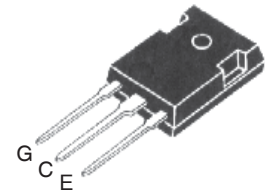

| Symbol | Test Conditions | Maximum Ratings | |
|---------------------|---|---------------------------------|------------------|
| V_{CES} | $T_J = 25^\circ\text{C to } 150^\circ\text{C}$ | 600 | V |
| V_{CGR} | $T_J = 25^\circ\text{C to } 150^\circ\text{C}; R_{GE} = 1 \text{ M}\Omega$ | 600 | V |
| V_{GES} | Continuous | ± 20 | V |
| V_{GEM} | Transient | ± 30 | V |
| I_{C25} | $T_C = 25^\circ\text{C}$ | 40 | A |
| I_{C110} | $T_C = 110^\circ\text{C}$ | 16 | A |
| I_{F110} | $T_C = 110^\circ\text{C}$ (IXG_16N60B2D1 diode) | 11 | A |
| I_{CM} | $T_C = 25^\circ\text{C}, 1 \text{ ms}$ | 100 | A |
| SSOA (RBSOA) | $V_{GE} = 15 \text{ V}, T_J = 125^\circ\text{C}, R_G = 22 \Omega$ Clamped inductive load | $I_{CM} = 32$ @0.8 V_{CES} | A |
| P_C | $T_C = 25^\circ\text{C}$ | 150 | W |
| T_J | | -55 ... +150 | $^\circ\text{C}$ |
| T_{JM} | | 150 | $^\circ\text{C}$ |
| T_{stg} | | -55 ... +150 | $^\circ\text{C}$ |
| M_d | Mounting torque | 1.13/10 Nm/lb.in. | |
| | Maximum lead temperature for soldering 1.6 mm (0.062 in.) from case for 10 s | 300 | $^\circ\text{C}$ |
| Weight | | 6 | g |

TO-247 (IXGH)

G = Gate C = Collector
E = Emitter TAB = Collector

Features

- International standard packages
- IGBT and anti-parallel FRED for resonant power supplies
 - Induction heating
 - Rice cookers
- MOS Gate turn-on
 - drive simplicity
- Fast Recovery Expitaxial Diode (FRED)
 - soft recovery with low I_{RM}

Advantages

- Saves space (two devices in one package)
- Easy to mount with 1 screw
- Reduces assembly time and cost

| Symbol | Test Conditions | Characteristic Values ($T_J = 25^\circ\text{C}$, unless otherwise specified) | | |
|---------------|--|---|------|--------------------------|
| | | min. | typ. | max. |
| $V_{GE(th)}$ | $I_C = 250 \mu\text{A}, V_{CE} = V_{GE}$ | 2.5 | | 5.0 V |
| I_{CES} | $V_{CE} = V_{CES}$ $V_{GE} = 0 \text{ V}$ $T_J = 125^\circ\text{C}$ | | | 50 μA 1 mA |
| I_{GES} | $V_{CE} = 0 \text{ V}, V_{GE} = \pm 20 \text{ V}$ | | | $\pm 100 \text{ nA}$ |
| $V_{CE(sat)}$ | $I_C = 12 \text{ A}, V_{GE} = 15 \text{ V}$ Note 2 $T_J = 125^\circ\text{C}$ | | 1.8 | 2.0 V V |

| Symbol | Test Conditions | Characteristic Values ($T_J = 25^\circ\text{C}$, unless otherwise specified) | | |
|--------------|---|---|------|-------------------|
| | | min. | typ. | max. |
| g_{fs} | $I_C = 12\text{A}; V_{CE} = 10\text{V}$, Note 2. | 8 | 12 | S |
| C_{ies} | $V_{CE} = 25\text{V}, V_{GE} = 0\text{V}, f = 1\text{MHz}$ | | 780 | pF |
| C_{oes} | | | 65 | pF |
| C_{res} | | | 19 | pF |
| Q_g | $I_C = 20\text{A}, V_{GE} = 15\text{V}, V_{CE} = 0.5 V_{CES}$ | | 32 | nC |
| Q_{ge} | | | 6 | nC |
| Q_{gc} | | | 10 | nC |
| $t_{d(on)}$ | | | 25 | ns |
| t_{ri} | Inductive load, $T_J = 25^\circ\text{C}$ | | 15 | ns |
| $t_{d(off)}$ | $I_C = 12\text{A}; V_{GE} = 15\text{V}$ | | 70 | 150 ns |
| t_{fi} | $V_{CE} = 400\text{V}; R_G = R_{off} = 22\ \Omega$ Note 1. | | 80 | 150 ns |
| E_{off} | | | 150 | 260 μJ |
| $t_{d(on)}$ | | | 25 | ns |
| t_{ri} | Inductive load, $T_J = 125^\circ\text{C}$ | | 18 | ns |
| E_{on} | $I_C = 12\text{A}; V_{GE} = 15\text{V}$ | | 700 | μJ |
| $t_{d(off)}$ | $V_{CE} = 400\text{V}; R_G = R_{off} = 22\ \Omega$ | | 110 | ns |
| t_{fi} | Note 1 | | 170 | ns |
| E_{off} | | | 350 | μJ |
| R_{thJC} | | | | 0.83 K/W |
| R_{thCK} | | | 0.25 | K/W |

TO-247 Outline

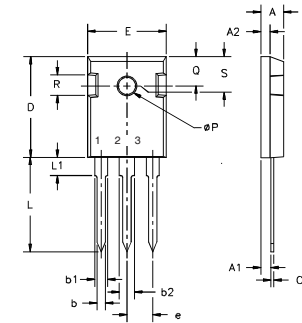

Terminals: 1 - Gate 2 - Drain
3 - Source Tab - Drain

| Dim. | Millimeter | | Inches | |
|----------------|------------|-------|--------|-------|
| | Min. | Max. | Min. | Max. |
| A | 4.7 | 5.3 | .185 | .209 |
| A ₁ | 2.2 | 2.54 | .087 | .102 |
| A ₂ | 2.2 | 2.6 | .059 | .098 |
| b | 1.0 | 1.4 | .040 | .055 |
| b ₁ | 1.65 | 2.13 | .065 | .084 |
| b ₂ | 2.87 | 3.12 | .113 | .123 |
| C | .4 | .8 | .016 | .031 |
| D | 20.80 | 21.46 | .819 | .845 |
| E | 15.75 | 16.26 | .610 | .640 |
| e | 5.20 | 5.72 | 0.205 | 0.225 |
| L | 19.81 | 20.32 | .780 | .800 |
| L1 | | 4.50 | | .177 |
| ∅P | 3.55 | 3.65 | .140 | .144 |
| Q | 5.89 | 6.40 | 0.232 | 0.252 |
| R | 4.32 | 5.49 | .170 | .216 |
| S | 6.15 | BSC | 242 | BSC |

| Symbol | Test Conditions | Characteristic Values ($T_J = 25^\circ\text{C}$, unless otherwise specified) | | |
|------------|---|---|------|------------------|
| | | min. | typ. | max. |
| V_F | $I_F = 10\text{A}, V_{GE} = 0\text{V}$ $T_J = 125^\circ\text{C}$ | | | 2.66 V 1.66 V |
| I_{RM} | $I_F = 12\text{A}; -di_F/dt = 100\text{A}/\mu\text{s}, V_R = 100\text{V}$ | | 2.5 | A |
| t_{rr} | $V_{GE} = 0\text{V}; T_J = 125^\circ\text{C}$ | | 110 | ns |
| t_{rr} | $I_F = 1\text{A}; -di_F/dt = 100\text{A}/\mu\text{s}; V_R = 30\text{V}, V_{GE} = 0\text{V}$ | | 30 | ns |
| R_{thJC} | | | | 2.5 K/W |

- Notes:
- Switching times may increase for $V_{CE}(\text{Clamp}) > 0.8 \cdot V_{CES}$, higher T_J or increased R_G .
 - Pulse test, $t < 300\ \mu\text{s}$, duty cycle $d < 2\%$

IXYS reserves the right to change limits, test conditions, and dimensions.