

Very High Voltage IGBT

IXEL40N400

$$\begin{aligned}
 V_{CES} &= 4000 \text{ V} \\
 I_{C90} &= 40 \text{ A} \\
 V_{CE(sat)} &= 4.0 \text{ V} \\
 t_{fi(typ)} &= 450 \text{ ns}
 \end{aligned}$$

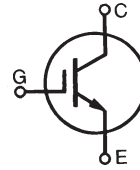

Symbol	Test Conditions	Maximum Ratings	
V_{CES}	$T_J = 25^\circ\text{C}$ to 125°C	4000	V
V_{GES}	Continuous	± 20	V
I_{C90}	$T_C = 90^\circ\text{C}$	40	A
I_{CM}	Limited by T_J	170	A
P_C	$T_C = 25^\circ\text{C}$	380	W
T_J		-40 ... +125	$^\circ\text{C}$
T_{JM}		125	$^\circ\text{C}$
T_{stg}		-40 ... +125	$^\circ\text{C}$
Maximum Lead temperature for soldering 1.6 mm (0.062 in.) from case for 10 s		300	$^\circ\text{C}$
Maximum Tab temperature for soldering SMD devices for 10 s		260	$^\circ\text{C}$
F_C	Mounting Force	30..170 / 7..36	N/lb
V_{ISOL}	$I_{ISOL} < 1 \text{ mA}$, 50/60 Hz, $t = 1 \text{ minute}$	2500	V~
Weight		10	g

ISOPLUS i5 (HV)

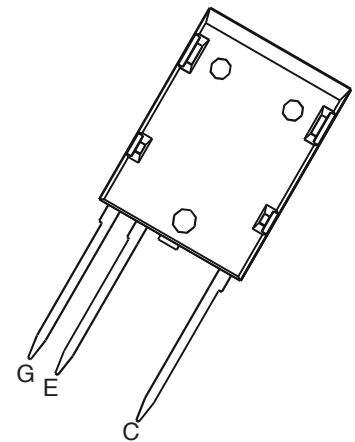

Features

- High current handling capability
- MOS Gate turn-on
- drive simplicity
- Rugged NPT structure
- Molding epoxies meet UL 94 V-0 flammability classification

Applications

- Capacitor discharge
- Pulsar circuits

Symbol	Test Conditions	Characteristic Values ($T_J = 25^\circ\text{C}$, unless otherwise specified)			
		min.	typ.	max.	
$V_{GE(th)}$	$I_C = 10 \text{ mA}$, $V_{CE} = V_{GE}$	6.0		7.5	V
I_{CES}	$V_{CE} = 4000 \text{ V}$ $V_{GE} = 0 \text{ V}$ $T_J = 125^\circ\text{C}$		1.5	100	μA mA
I_{GES}	$V_{CE} = 0 \text{ V}$, $V_{GE} = \pm 20 \text{ V}$			± 500	nA
$V_{CE(sat)}$	$I_C = I_{C90}$, $V_{GE} = 15 \text{ V}$ $T_J = 125^\circ\text{C}$		3.0 3.9	4.0	V V

Symbol	Test Conditions	Characteristic Values ($T_J = 25^\circ\text{C}$ unless otherwise specified)		
		min.	typ.	max.
g_{fs}	$I_C = I_{C90}, V_{CE} = 10\text{ V}$,		21	S
I_{SC}	$V_{CC} = 3400\text{ V}, V_{CM} < 4000\text{ V}, V_{GE} = 15\text{ V}$ $T_J = 125^\circ\text{C}, t_{SC} \leq 10\ \mu\text{s}$		175	A
C_{ies}	$V_{CE} = 25\text{ V}, V_{GE} = 0\text{ V}, f = 1\text{ MHz}$		7450	pF
C_{oes}			280	pF
C_{res}			70	pF
Q_{ge}	$I_C = I_{C90}, V_{GE} = 15\text{ V}, V_{CE} = 0.5 V_{CES}$		310	nC
R_{Gint}			5	Ω
$t_{d(on)}$	Inductive load		170	ns
t_{ri}	$I_C = I_{C90}, V_{GE} = \pm 15\text{ V}$		100	ns
E_{on}	$V_{CE} = 2800\text{ V}, R_G = 33\ \Omega$		54	mJ
$t_{d(off)}$			660	ns
t_{fi}			450	ns
E_{off}			170	mJ
$t_{d(on)}$	Inductive load, $T_J = 125^\circ\text{C}$		165	ns
t_{ri}	$I_C = I_{C90}, V_{GE} = \pm 15\text{ V}$		105	ns
E_{on}	$V_{CE} = 2800\text{ V}, R_G = 33\ \Omega$		72	mJ
$t_{d(off)}$			750	ns
t_{fi}			480	ns
E_{off}			220	mJ
R_{thJC}				0.33 K/W
R_{thCK}	(Pressure mount)		0.15	K/W

ISOPLUS i5 HV Outline

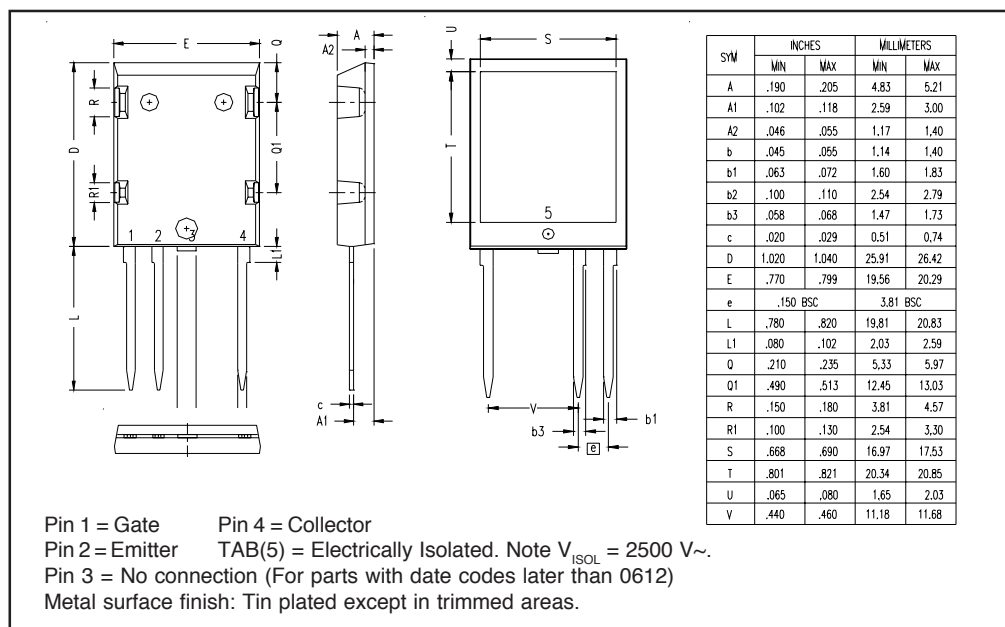

IXYS reserves the right to change limits, test conditions, and dimensions.

IXYS MOSFETs and IGBTs are covered by one or more of the following U.S. patents:	4,835,592	4,931,844	5,049,961	5,237,481	6,162,665	6,404,065 B1	6,683,344	6,727,585
	4,850,072	5,017,508	5,063,307	5,381,025	6,259,123 B1	6,534,343	6,710,405 B2	6,759,692
	4,881,106	5,034,796	5,187,117	5,486,715	6,306,728 B1	6,583,505	6,710,463	6771478 B2

Fig. 1. Output Characteristics
@ 25 °C

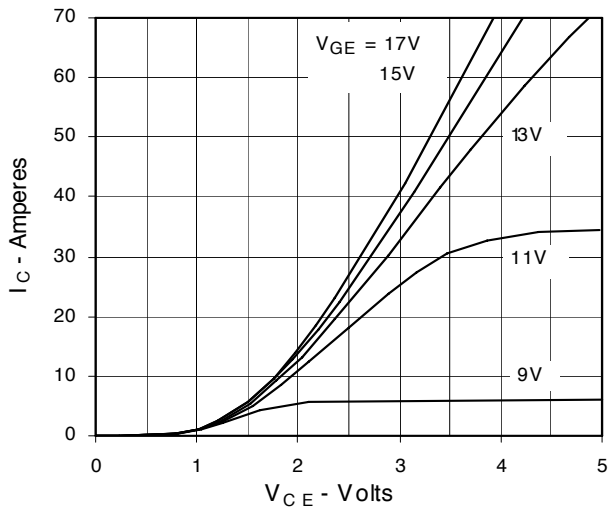

Fig. 2. Extended Output Characteristics
@ 25 °C

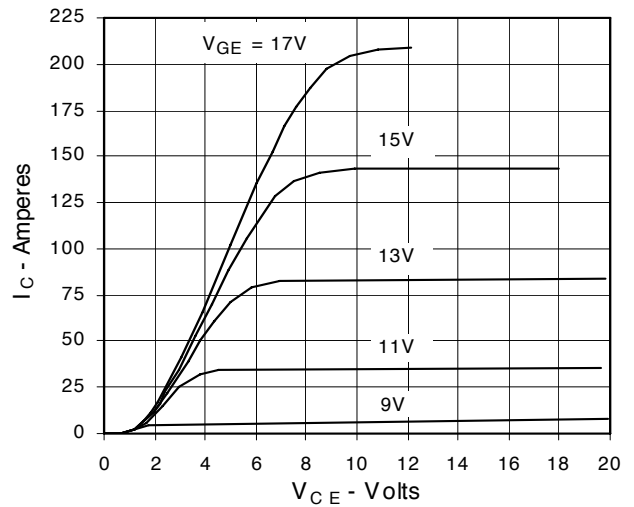

Fig. 3. Output Characteristics
@ 125 °C

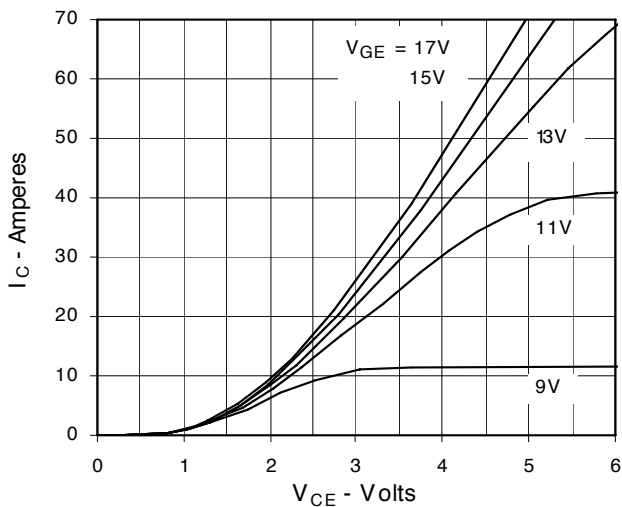

Fig. 4. Dependence of $V_{CE(sat)}$ on Temperature

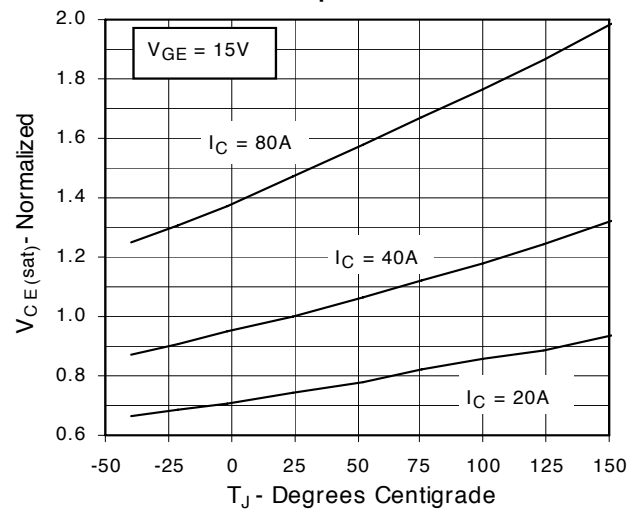

Fig. 5. Collector-to-Emitter Voltage vs. Gate-to-Emitter voltage

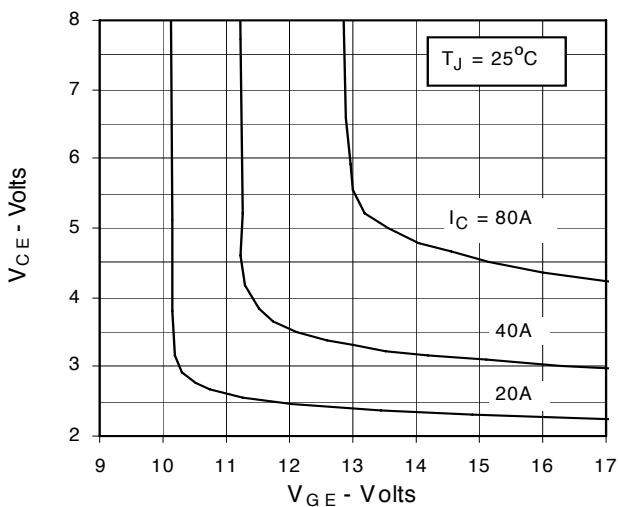

Fig. 6. Input Admittance

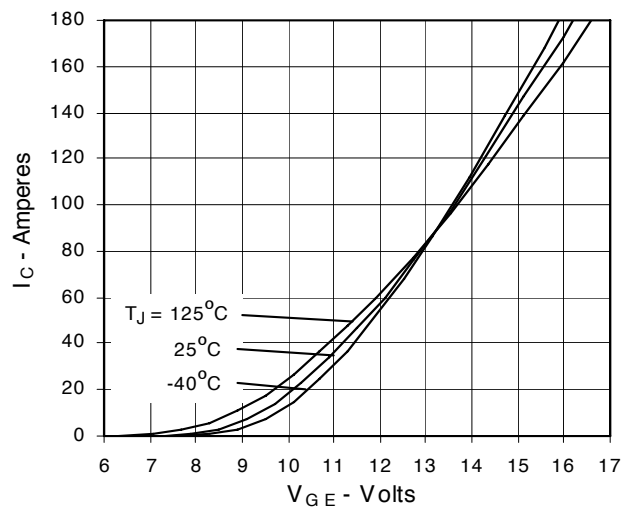

Fig. 7. Transconductance

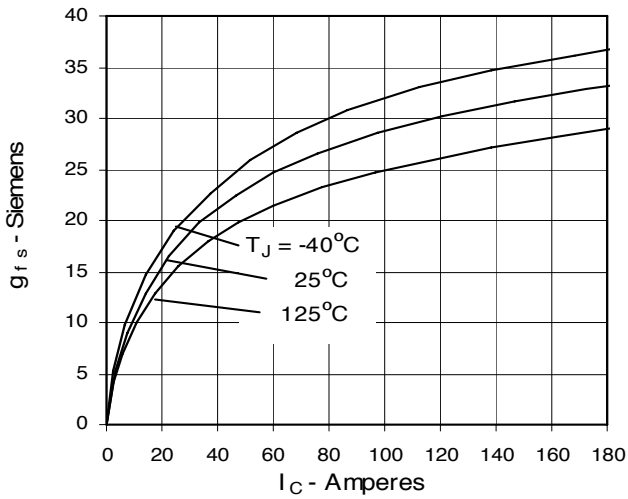

Fig. 8. Turn-on & Turn-off Energies vs. Collector Current

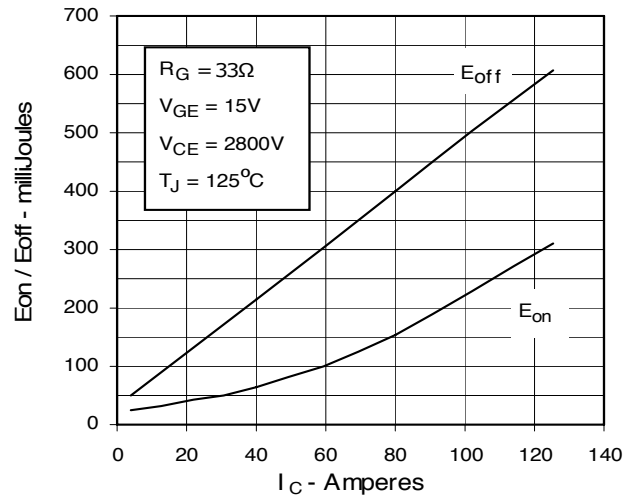

Fig. 9. Turn-on & Turn-off Energies vs. Gate Resistance

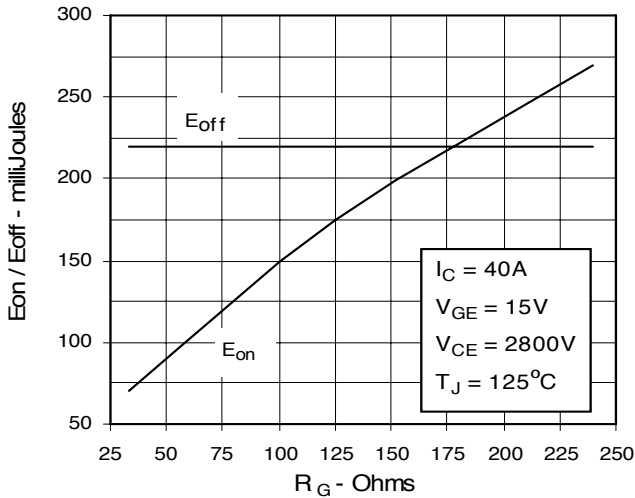

Fig. 10. Gate Charge

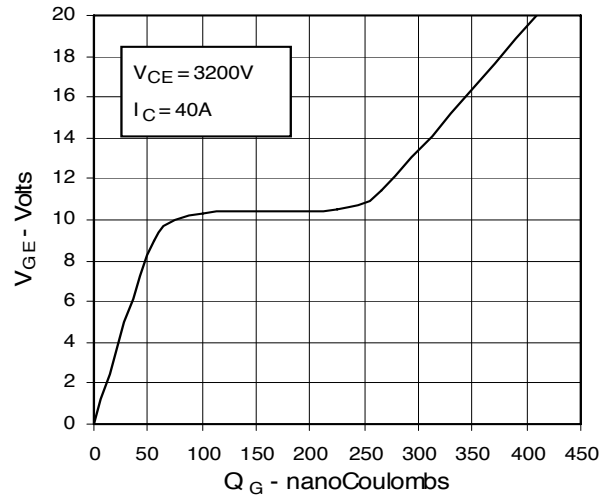

Fig. 11. Capacitance

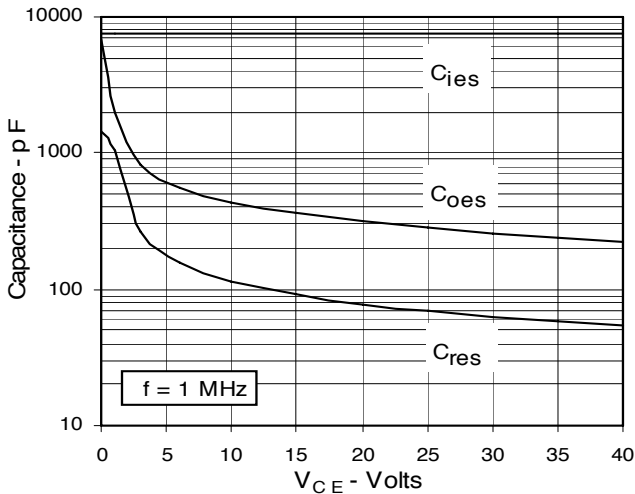

Fig. 12. Maximum Transient Thermal Resistance

