

### Features

- Single Stage, Primary Control with PFC and Dimming Features
- >90% Efficiency
- Power Factor >98%
- Wide Operating Voltage Range: Up to 600V
- Digital Soft-Start
- Cycle-by-Cycle Peak Current Control

### Applications

- Incandescent Bulb Replacement
- Solid State Lighting
- Industrial and Commercial Lighting



### Description

The IX9908 is a quasi-resonant controller optimized for phase-cut dimmable, off-line LED applications. Precise PWM generation supports phase-cut dimming and power factor correction.

The product features a wide operating range, up to 600V, and low power consumption. Multiple safety features ensure full system protection in failure situations. The IX9908, with its strong feature set and low cost, is an excellent choice for quasi-resonant flyback LED bulb designs.

### Ordering Information

Part	Description
IX9908N	8-Pin SOIC (100/Tube)
IX9908NTR	8-Pin SOIC (2000/Reel)

### IX9908 Example Application

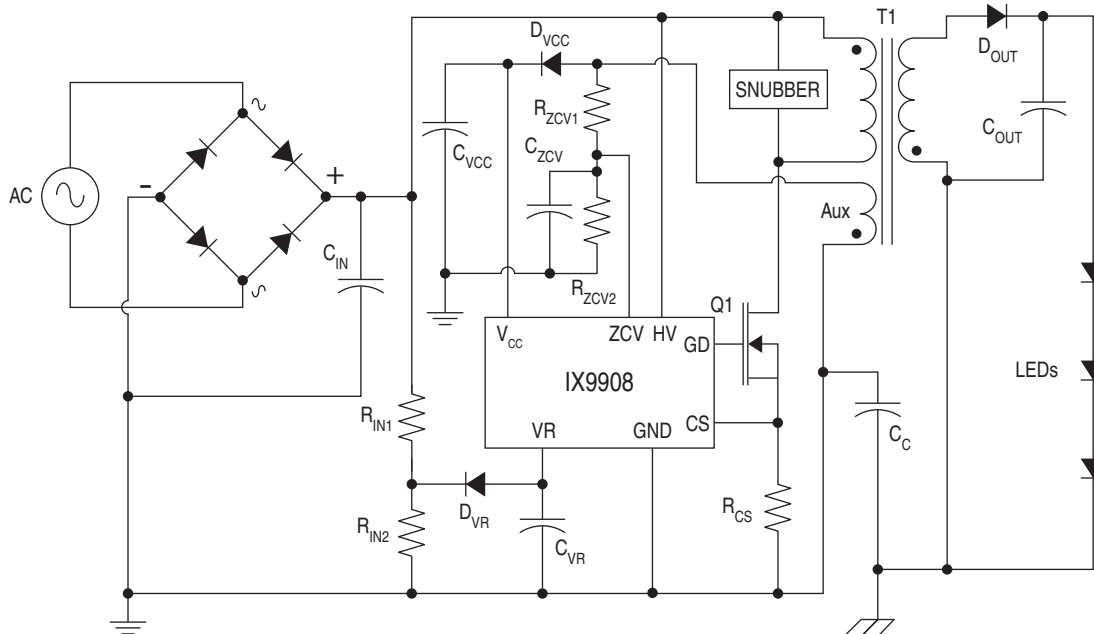

---

<b>1. Specifications</b>	<b>3</b>
1.1 Package Pinout	3
1.2 Absolute Maximum Ratings	3
1.3 Pin Description	3
1.4 Recommended Operating Range	3
1.5 Electrical Characteristics	4
<b>2. Functional Description</b>	<b>6</b>
2.1 Internal Supply Voltage During Start-Up	6
2.2 Soft-Start	7
2.3 Normal Operation	7
<b>3. Manufacturing Information</b>	<b>9</b>
3.1 Moisture Sensitivity	9
3.2 ESD Sensitivity	9
3.3 Reflow Profile	9
3.4 Board Wash	9
3.5 Package Dimensions	10
3.6 Tape & Reel Dimensions	10

# 1. Specifications

## 1.1 Package Pinout

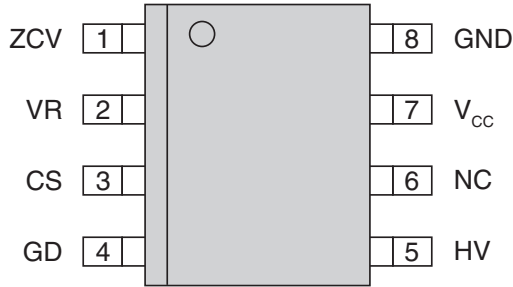

## 1.2 Absolute Maximum Ratings

Parameter	Symbol	Ratings	Unit
HV Voltage	V <sub>HV</sub>	600	V
V <sub>CC</sub> Supply Voltage	V <sub>CC</sub>	-0.3 to 40	V
VR Voltage	V <sub>VR</sub>	-0.3 to 5	V
ZCV Voltage	V <sub>ZC</sub>	-0.3 to 5	V
CS Voltage	V <sub>CS</sub>	-0.3 to 5	V
GD Voltage	V <sub>OUT</sub>	-0.3 to 40	V
Maximum Current from ZCV Pin	I <sub>ZCmax</sub>	3	mA
Junction Temperature	T <sub>J</sub>	- 40 to +125	°C
Storage Temperature	T <sub>STG</sub>	- 55 to +150	°C
Thermal Resistance Junction to Ambient	θ <sub>JA</sub>	125	°C/W

Absolute maximum electrical ratings are at 25°C.

Absolute maximum ratings are stress ratings. Stresses in excess of these ratings can cause permanent damage to the device. Functional operation of the device at conditions beyond those indicated in the operational sections of this data sheet is not implied.

## 1.3 Pin Description

Pin#	Name	Description
1	ZCV	Zero Crossing
2	VR	Voltage Sense
3	CS	Current Sense
4	GD	Gate Drive Output
5	HV	High Voltage Input
6	NC	Not Connected
7	V <sub>CC</sub>	Controller Power Supply
8	GND	Controller Ground

## 1.4 Recommended Operating Range

Note: Within the operating range the IC operates as described in the functional description.

Parameter	Symbol	Limit Values		Unit
		Min	Max	
V <sub>CC</sub> Supply Voltage	V <sub>CC</sub>	10.5	18	V
Junction Temperature	T <sub>J</sub>	- 25	+ 125	°C

## 1.5 Electrical Characteristics

 $T_J = -25^{\circ}\text{C to } +125^{\circ}$ 

### 1.5.1 Power Supply

Note: The electrical characterization involves the spread of values within the specified supply voltage and junction temperature range  $T_J$  from  $-25^{\circ}\text{C}$  to  $+125^{\circ}\text{C}$ . Typical values represent the median values, which are related to  $25^{\circ}\text{C}$ . If not otherwise stated, a supply voltage of  $V_{CC}=18\text{V}$  is assumed.

Parameter	Conditions	Symbol	Minimum	Typical	Maximum	Unit
$V_{CC}$ Charge Current	$V_{CC}=0\text{V}$	$I_{CC\text{charge}1}$	-	-	35	mA
	$V_{CC}=V_{CC\text{on}} - 0.2\text{V}$	$I_{CC\text{charge}2}$	-	-	35	
Maximum Input Current of Startup Cell	$V_{CC}=V_{CC\text{on}} - 0.2\text{V}$	$I_{HV}$	-	-	35	mA
Leakage Current of Startup Cell	$V_{HV}=610\text{V @ } T_J=100^{\circ}\text{C}$	$I_{HV}$	-	0.2	50	$\mu\text{A}$
Supply Current in Normal Operation	GD Low	$I_{CC\text{NM}}$	-	1.8	2.9	mA
$V_{CC}$ Turn-On Threshold	-	$V_{CC\text{on}}$	17	18	19	V
$V_{CC}$ Turn-Off Threshold	-	$V_{CC\text{off}}$	9.8	10.5	11.2	V
$V_{CC}$ Turn-On/Off Hysteresis	-	$V_{CC\text{hys}}$	-	7.5	-	V

### 1.5.2 Internal Voltage Reference

Parameter	Conditions	Symbol	Minimum	Typical	Maximum	Unit
Internal Reference Voltage	Measured at VR Pin, $I_{VR}=0$	$V_{VR}$	4.8	5	5.2	V

### 1.5.3 PWM Section

Parameter	Conditions	Symbol	Minimum	Typical	Maximum	Unit
VR Pull-Up Resistor	-	$R_{VR}$	14	23	33	$\text{k}\Omega$
PWM-OP Gain	-	$G_{\text{PWM}}$	2.95	3	3.05	-
Offset for Voltage Ramp	-	$V_{\text{PWM}}$	0.63	0.7	0.77	V
Maximum On-Time in Normal Operation	-	$t_{\text{onMax}}$	22	30	41	$\mu\text{s}$

### 1.5.4 Current Sense

Parameter	Conditions	Symbol	Minimum	Typical	Maximum	Unit
Current Sense Threshold	-	$V_{\text{CSTH}}$	0.97	1.03	1.09	V
Leading Edge Blanking Time	-	$t_{\text{BLKCS}}$	200	330	460	ns

### 1.5.5 Soft Start

Parameter	Conditions	Symbol	Minimum	Typical	Maximum	Unit
Soft-Start Time	-	$t_{\text{SS}}$	8.5	12	-	ms
Soft-Start Time Step	-	$t_{\text{SS-S}}$	-	3	-	ms
Internal Regulation Voltage at First Step	-	$V_{\text{SS1}}$	-	1.76	-	V
Internal Regulation Voltage Step at Soft Start	-	$V_{\text{SS-S}}$	-	0.56	-	V

**1.5.6 Foldback Point Correction**

Parameter	Conditions	Symbol	Minimum	Typical	Maximum	Unit
ZCV Current First Step Threshold	-	$I_{ZC\_FS}$	0.35	0.5	0.621	mA
ZCV Current Last Step Threshold	-	$I_{ZC\_LS}$	1.3	1.85	2.3	mA
CS Threshold Minimum	$I_{ZC} = 2.3 \text{ mA}, V_{VR} = 3.0\text{V}$	$V_{CSMF}$	-	0.66	-	V

**1.5.7 Digital Zero Crossing**

Parameter	Conditions	Symbol	Minimum	Typical	Maximum	Unit
Zero Crossing Voltage	-	$V_{ZCCT}$	50	100	170	mV
Ringing Suppression Threshold	-	$V_{ZCRS}$	-	0.7	-	V
Minimum Ringing Suppression Time	$V_{ZC} > V_{ZCRS}$	$t_{ZCRS1}$	1.62	2.5	4.5	$\mu\text{s}$
Maximum Ringing Suppression Time	$V_{ZC} < V_{ZCRS}$	$t_{ZCRS2}$	-	42	-	$\mu\text{s}$
Maximum Restart Time in Normal Operation	-	$t_{OffMax}$	30	42	57.5	$\mu\text{s}$

**1.5.8 Protection**

Parameter	Conditions	Symbol	Minimum	Typical	Maximum	Unit
$V_{CC}$ Overvoltage Threshold	-	$V_{CCOVP}$	24	25	26	V
Output Overvoltage Detection Threshold at the ZCV Pin	-	$V_{ZCVOVP}$	3.55	3.7	3.87	V
Blanking Time for Output Overvoltage Protection	-	$t_{ZCVOVP}$	-	100	-	$\mu\text{s}$
Threshold for Short Winding Protection	-	$V_{CSSW}$	1.60	1.68	1.78	V
Blanking Time for Short Winding Protection	-	$t_{CSSW}$	-	190	-	ns
Over-Temperature Protection	-	$T_{JTSP}$	-	140	-	$^{\circ}\text{C}$

**1.5.9 Gate Drive**

Parameter	Conditions	Symbol	Minimum	Typical	Maximum	Unit
Output Voltage at Logic Low	$V_{CC}=18\text{V}, I_{OUT}=10\text{mA}$	$V_{GATElow}$	-	-	1	V
Output Voltage at Logic High	$V_{CC}=18\text{V}, I_{OUT}=-10\text{mA}$	$V_{GATEhigh}$	9	10	-	V
Output Voltage Active Shut-Down	$V_{CC}=9\text{V}, I_{OUT}=10\text{mA}$	$V_{GATEasd}$	-	-	1	V
Rise Time	$C_{OUT}=1\text{nF}, V_{GD}=2\text{V to }8\text{V}$	$t_{rise}$	-	117	-	ns
Fall Time	$C_{OUT}=1\text{nF}, V_{GD}=8\text{V to }2\text{V}$	$t_{fall}$	-	27	-	ns

## 2. Functional Description

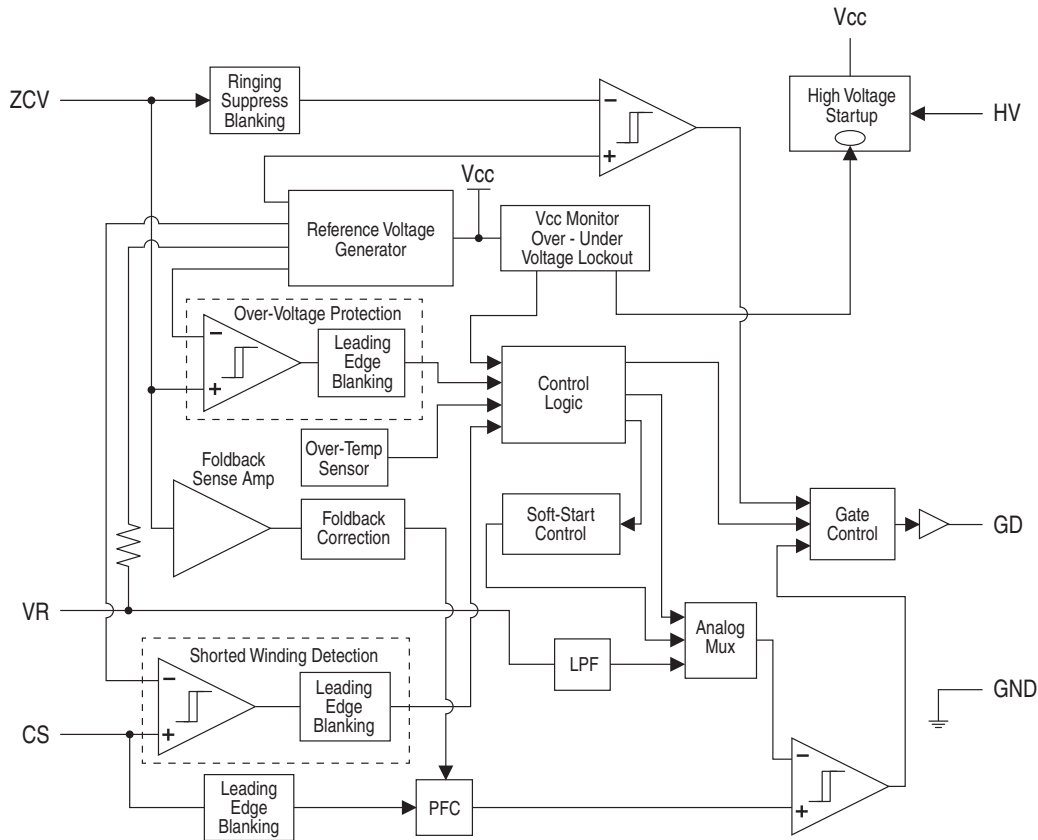

Figure 1. IX9908 Block Diagram

### 2.1 Internal Supply Voltage During Start-Up

The IX9908 integrates a high voltage startup cell. This cell provides a constant current to charge the  $V_{CC}$  capacitor ( $C_{VCC}$ ) during the Power-up phase of operation. Once the main input voltage is applied, a rectified voltage will be across  $C_{IN}$ .

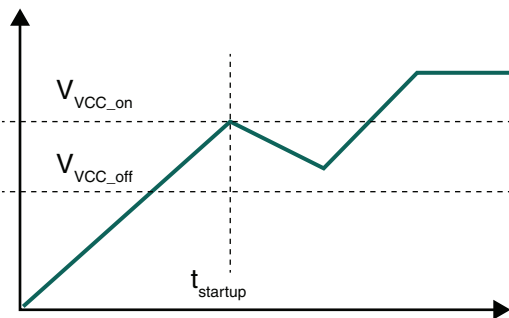

Figure 2. Start-Up

The start-up cell will sense this voltage, and source a constant current of approximately 10 mA to  $C_{VCC}$ . This current will remain until  $V_{CC}$  reaches  $V_{VCC\_on}$  or 18V nominal. It will then be switched off, and a soft start sequence will begin.  $V_{CC}$  will then sag as the  $C_{VCC}$  capacitor supplies current to power the device, and is not yet receiving energy from the auxiliary winding. Once the output voltage is high enough the auxiliary winding will provide energy to  $C_{VCC}$  and the  $V_{CC}$  voltage will reach a constant value. This value depends on the output load and transformer characteristics.

$$t_{startup} = \frac{V_{CC\_on} \cdot C_{VCC}}{I_{CC\_CHARGE}}$$

## 2.2 Soft-Start

Once  $V_{CC}$  reaches  $V_{VCC\_on}$  (typically 18V), the device will initiate a soft-start sequence. This is intended to minimize the electrical stresses on Q1,  $D_{OUT}$ ,  $D_{VCC}$ , and the transformer. The soft-start operates as shown in Figure 3. The duration of this soft-start is 12mS nominal and steps  $V_{CS}$ , the current sense voltage, to four values, as shown.

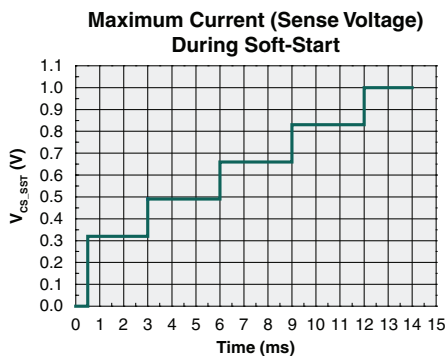

Figure 3. Soft-Start

## 2.3 Normal Operation

Because the IX9908 employs quasi-resonant operation, its PWM switch-on is set by the zero crossing of the auxiliary winding voltage, and the switch-off is set by the current sense voltage.

### 2.3.1 Zero Crossing & Switch-On Determination

As the application schematic on Page 1 shows, the voltage from the auxiliary winding is connected to the zero crossing pin, ZCV, through an RC network. This network provides a delay so that switch-on can occur at voltage valley thus enhancing efficiency. The required time delay,  $\Delta t$ , should be approximately one-fourth of the oscillation period (determined by transformer primary inductor and drain-source capacitance of Q1) minus the propagation delay from zero-cross detect to Q1 switch-on,  $t_{delay}$ .

$$\Delta t = \frac{t_{OSC}}{4} - t_{delay}$$

This time delay,  $\Delta t$ , should be matched by adjusting the RC network.

$$t_{RC} = C_{ZCV} (R_{ZCV1} // R_{ZCV2})$$

After Q1 is turned off, its  $V_{DS}$  will show some oscillation. This will also show on the ZCV input. To avoid a mis-triggered Q1 turn-on, a ringing

suppression circuit is implemented. The suppression time has two values that depend on the voltage at ZCV. If  $V_{ZCV}$  is greater than 0.7V, then the time is 2.5 $\mu$ S nominal. If  $V_{ZCV}$  is less than 0.7V, then the time is 42 $\mu$ S nominal. Turn-on of Q1 can not occur during the suppression time, but does occur after a zero-crossing is detected. In the case of a missed zero-crossing, a maximum off-time is implemented. After Q1 has been off for 42 $\mu$ S nominal ( $t_{offMax}$ ), it is turned back on.

### 2.3.2 Switch-Off Determination

In the application circuit the primary current is sensed by  $R_{CS}$ . The voltage across this resistor,  $V_{CS}$ , is applied to the CS input of the device. It is processed internally ( $V_{CSINT} = V_{CS(3)} + 0.7V$ ), and compared to the voltage at the VR pin, which is a scaled version of the rectified line voltage. When  $V_{CSINT} > VR$ , the power switch Q1 is turned off.

Leading-edge blanking is used to prevent a false trigger caused by the voltage spike across  $R_{CS}$  at the moment of Q1 turn-on. This blanking time,  $t_{BLKCS}$ , is nominally 330nS. To prevent transformer saturation, a maximum on-time circuit is implemented. Max on-time for Q1 (GD=H) is 30 $\mu$ S nominal.

### 2.3.3 Foldback Point Correction

When the AC line voltage increases, the Q1 on-time decreases, which increases the operating frequency. As a result, with a constant primary current limit, the output power increases. To provide output power regulation with respect to line voltage, the internal foldback point correction circuit varies the  $V_{CS}$  limit. The  $V_{CS}$  limit is decreased in response to an increase in AC line voltage. The relationship between  $V_{CSMax}$  and  $V_{IN}$  is shown in Figure 4.

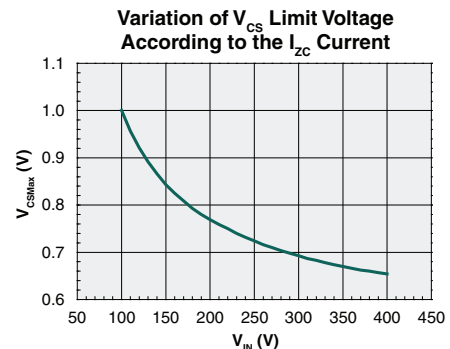

Figure 4.  $V_{CSMax}$  vs.  $V_{IN}$

The variation in AC line voltage is sensed by way of the auxiliary winding and an internal clamp and current sense circuit. When Q1 is on, a negative voltage proportional to the line voltage is coupled to the auxiliary winding; the IC will hold the ZCV pin very close to ground during this time. The line voltage is thus sensed indirectly through the current in  $R_{ZCV1}$ . This current is given by:

$$I_{ZCV} = \frac{V_{IN} \cdot N_a}{R_{ZCV1} \cdot N_p}$$

The device uses  $I_{ZCV}$  to vary the  $V_{CS}$  limit as shown in Figure 4. The actual implementation is digital and is shown below:

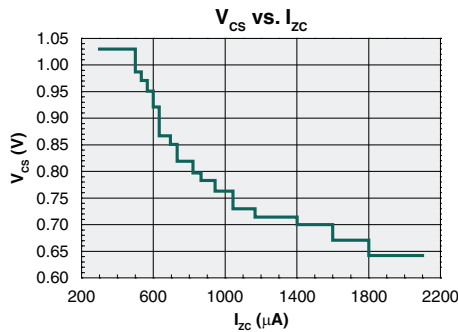

Figure 5.  $V_{CS}$  vs.  $I_{ZC}$

### 2.3.4 Protection Functions

The IX9908 provides comprehensive protection features. They are summarized in the table below:

Fault Condition	Action Taken
Output Over-Voltage	GD Latched Off
Shorted Winding	GD Latched Off
Over-Temperature	Auto-Restart Mode
VCC Over-Voltage	Auto-Restart Mode
VCC Under-Voltage	Auto-Restart Mode

#### OUTPUT OVER-VOLTAGE

During the Q1 off-time the auxiliary winding voltage ( $V_{AUX}$ ) will swing positive and in proportion to the secondary voltage.  $V_{AUX}$  is connected to ZCV through a resistor divider. If the voltage at ZCV exceeds a preset threshold ( $V_{ZCV OVP}$ ) for longer than the blanking time ( $t_{ZCV OVP}$ ), then the IC is latched off.

#### SHORTED WINDING

If the voltage at CS exceeds a preset threshold ( $V_{CSSW}$ ) during Q1 on time the device is latched off.

#### OVER-TEMPERATURE

If the die temperature exceeds 140°C, then the device will enter the Auto-Restart Mode.

#### V<sub>CC</sub> OVER-VOLTAGE / UNDER-VOLTAGE

The IC continuously monitors the  $V_{CC}$  voltage. In case of an over-voltage, Q1 is turned off (GD=L) and  $V_{CC}$  will begin to fall. Once  $V_{CC}$  goes below  $V_{VCC\_off}$  (10.5V nominal), the startup circuit is activated, and begins to charge  $C_{VCC}$ . When  $V_{CC}$  exceeds  $V_{VCC\_on}$  (18.0V nominal), the device initiates a new soft-start. For an under-voltage the operation is the same except that the sequence begins with  $V_{CC} < V_{VCC\_off}$  so GD=L and the startup circuit is activated. This operation describes the Auto-Restart Mode.

During Latch-Off Mode,  $V_{CC}$  also cycles between  $V_{VCC\_off}$  and  $V_{VCC\_on}$ , but GD remains low, and no soft-start is initiated. The line voltage must be turned off and on again to begin normal operation.

### 3. Manufacturing Information

#### 3.1 Moisture Sensitivity



All plastic encapsulated semiconductor packages are susceptible to moisture ingress. IXYS Integrated Circuits Division classified all of its plastic encapsulated devices for moisture sensitivity according to the latest version of the joint industry standard, **IPC/JEDEC J-STD-020**, in force at the time of product evaluation. We test all of our products to the maximum conditions set forth in the standard, and guarantee proper operation of our devices when handled according to the limitations and information in that standard as well as to any limitations set forth in the information or standards referenced below.

Failure to adhere to the warnings or limitations as established by the listed specifications could result in reduced product performance, reduction of operable life, and/or reduction of overall reliability.

This product carries a **Moisture Sensitivity Level (MSL) rating** as shown below, and should be handled according to the requirements of the latest version of the joint industry standard **IPC/JEDEC J-STD-033**.

Device	Moisture Sensitivity Level (MSL) Rating
IX9908N	MSL 1

#### 3.2 ESD Sensitivity



This product is **ESD Sensitive**, and should be handled according to the industry standard **JESD-625**.

#### 3.3 Reflow Profile

This product has a maximum body temperature and time rating as shown below. All other guidelines of **J-STD-020** must be observed.

Device	Maximum Temperature x Time
IX9908N	260°C for 30 seconds

#### 3.4 Board Wash

IXYS Integrated Circuits Division recommends the use of no-clean flux formulations. However, board washing to remove flux residue is acceptable, and the use of a short drying bake may be necessary. Chlorine-based or Fluorine-based solvents or fluxes should not be used. Cleaning methods that employ ultrasonic energy should not be used.



### 3.5 Package Dimensions

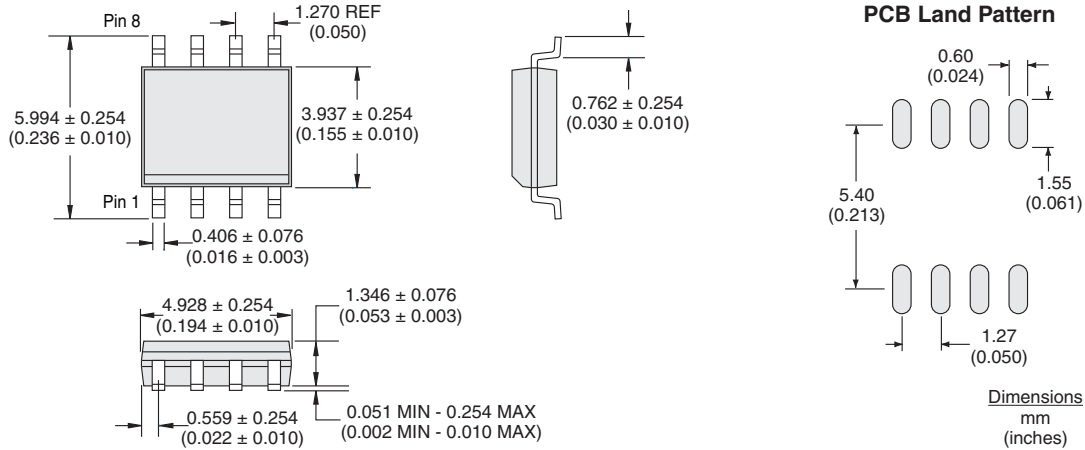

### 3.6 Tape & Reel Dimensions

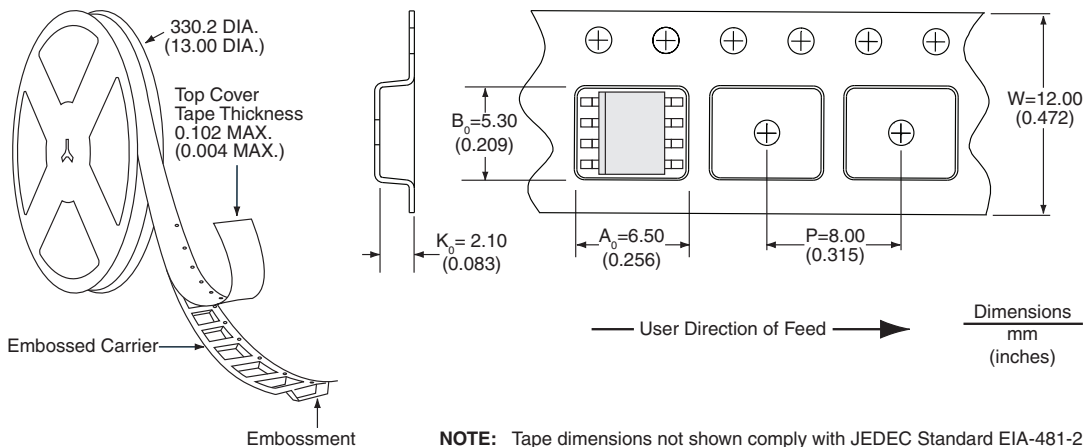

For additional information please visit [www.ixysic.com](http://www.ixysic.com)

IXYS Integrated Circuits Division makes no representations or warranties with respect to the accuracy or completeness of the contents of this publication and reserves the right to make changes to specifications and product descriptions at any time without notice. Neither circuit patent licenses or indemnity are expressed or implied. Except as set forth in IXYS Integrated Circuits Division's Standard Terms and Conditions of Sale, IXYS Integrated Circuits Division assumes no liability whatsoever, and disclaims any express or implied warranty relating to its products, including, but not limited to, the implied warranty of merchantability, fitness for a particular purpose, or infringement of any intellectual property right.

The products described in this document are not designed, intended, authorized, or warranted for use as components in systems intended for surgical implant into the body, or in other applications intended to support or sustain life, or where malfunction of IXYS Integrated Circuits Division's product may result in direct physical harm, injury, or death to a person or severe property or environmental damage. IXYS Integrated Circuits Division reserves the right to discontinue or make changes to its products at any time without notice.

Specifications: DS-IX9908-R01  
© Copyright 2013, IXYS Integrated Circuits Division  
All rights reserved. Printed in USA.  
7/3/2013

# Mouser Electronics

Authorized Distributor

Click to View Pricing, Inventory, Delivery & Lifecycle Information:

[IXYS:](#)

[IX9908NTR](#) [IX9908N](#)