

## 1M x 8 HIGH-SPEED CMOS STATIC RAM

AUGUST 2005

### FEATURES

- High-speed access times:  
8, 10 ns
- High-performance, low-power CMOS process
- Multiple center power and ground pins for greater noise immunity
- Easy memory expansion with  $\overline{CE}$  and  $\overline{OE}$  options
- $\overline{CE}$  power-down
- Fully static operation: no clock or refresh required
- TTL compatible inputs and outputs
- Single 3.3V power supply
- Packages available:
  - 48-ball miniBGA (9mm x 11mm)
  - 36-ball miniBGA (9mm x 11mm)
  - 44-pin TSOP (Type II)
- Lead-free available

### DESCRIPTION

The *ISSI* IS61LV10248 is a very high-speed, low power, 1M-word by 8-bit CMOS static RAM. The IS61LV10248 is fabricated using *ISSI*'s high-performance CMOS technology. This highly reliable process coupled with innovative circuit design techniques, yields higher performance and low power consumption devices.

When  $\overline{CE}$  is HIGH (deselected), the device assumes a standby mode at which the power dissipation can be reduced down with CMOS input levels.

The IS61LV10248 operates from a single 3.3V power supply and all inputs are TTL-compatible.

The IS61LV10248 is available in 48 ball mini BGA, 36-ball mini BGA, and 44-pin TSOP (Type II) packages.

### FUNCTIONAL BLOCK DIAGRAM

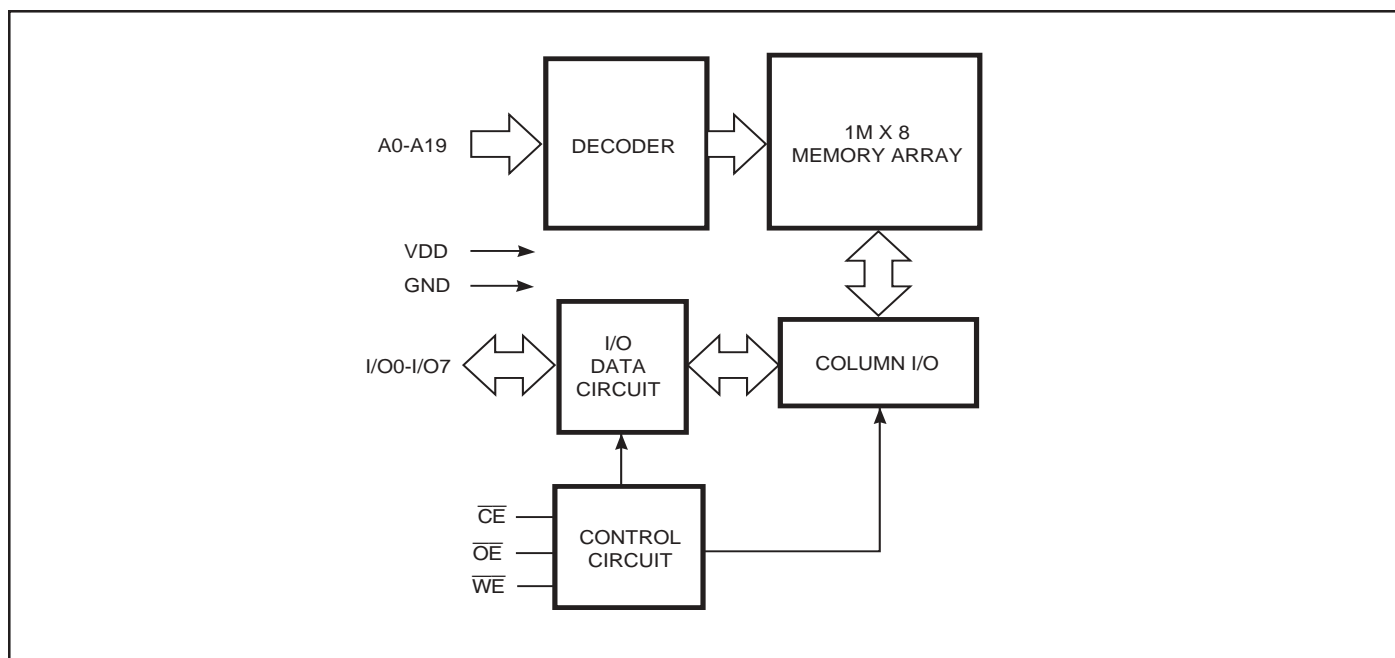

Copyright © 2003 Integrated Silicon Solution, Inc. All rights reserved. ISSI reserves the right to make changes to this specification and its products at any time without notice. ISSI assumes no liability arising out of the application or use of any information, products or services described herein. Customers are advised to obtain the latest version of this device specification before relying on any published information and before placing orders for products.

**PIN CONFIGURATION**

**36 mini BGA (B) (9mm x 11mm)**

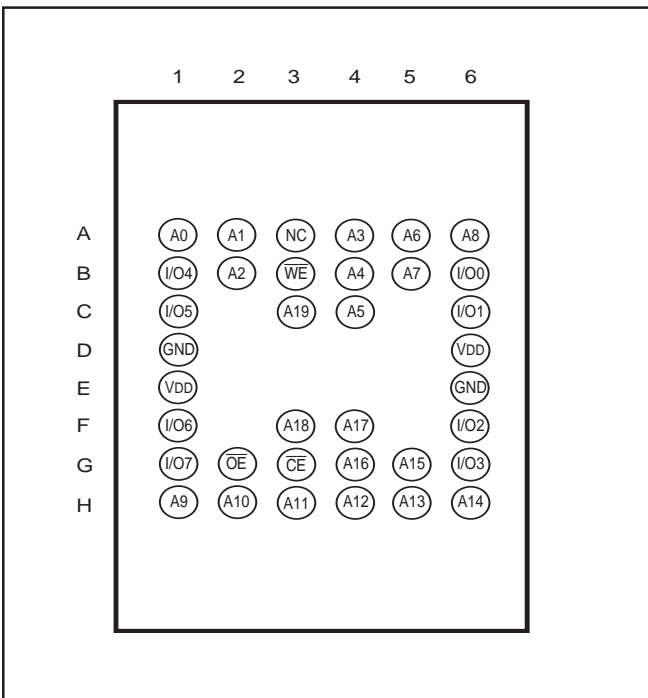

**48-pin Mini BGA (M) (9mm x 11mm)**

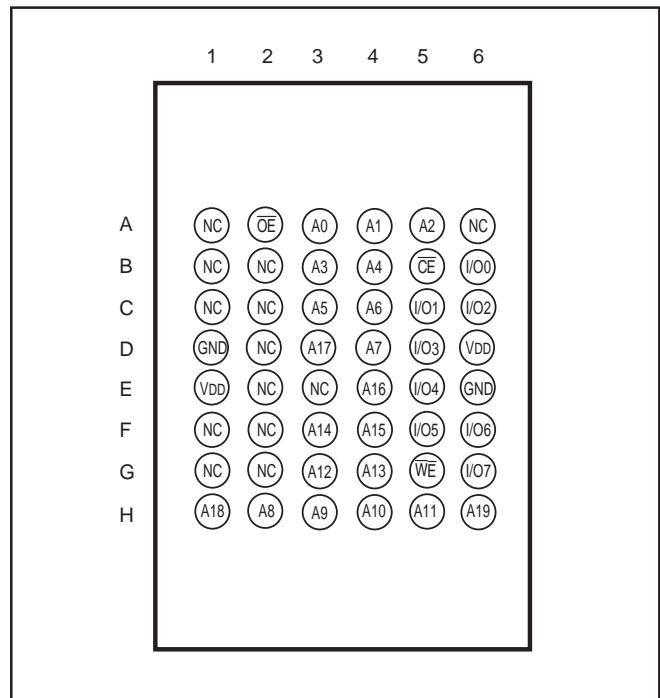

**PIN DESCRIPTIONS**

A0-A19	Address Inputs
CE	Chip Enable Input
OE	Output Enable Input
WE	Write Enable Input
I/O0-I/O7	Data Input / Output
VDD	Power
GND	Ground
NC	No Connection

**44-pin TSOP (Type II)**

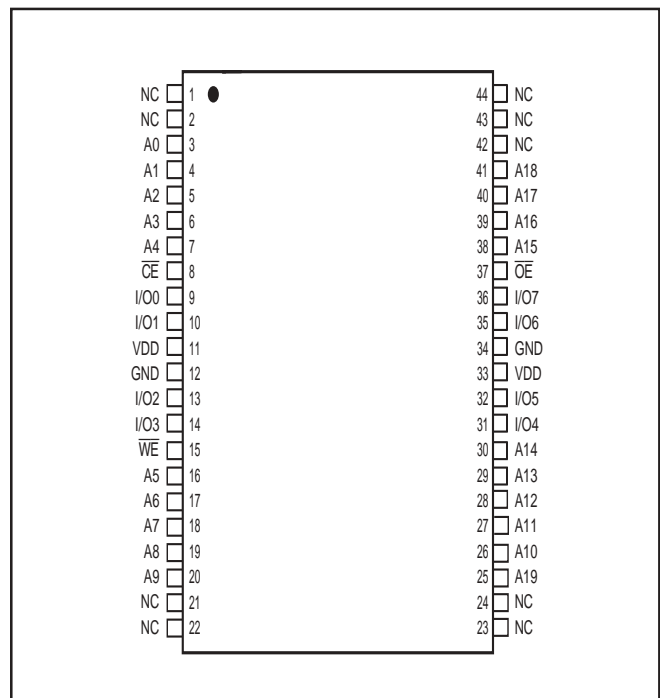

## TRUTH TABLE

Mode	$\overline{WE}$	$\overline{CE}$	$\overline{OE}$	I/O Operation	V <sub>DD</sub> Current
Not Selected (Power-down)	X	H	X	High-Z	I <sub>SB1</sub> , I <sub>SB2</sub>
Output Disabled	H	L	H	High-Z	I <sub>CC</sub>
Read	H	L	L	D <sub>OUT</sub>	I <sub>CC</sub>
Write	L	L	X	D <sub>IN</sub>	I <sub>CC</sub>

ABSOLUTE MAXIMUM RATINGS<sup>(1)</sup>

Symbol	Parameter	Value	Unit
V <sub>TERM</sub>	Terminal Voltage with Respect to GND	-0.5 to V <sub>DD</sub> + 0.5	V
V <sub>DD</sub>	V <sub>DD</sub> Relates to GND	-0.3 to 4.0	V
T <sub>STG</sub>	Storage Temperature	-65 to +150	°C
P <sub>T</sub>	Power Dissipation	1.0	W

## Notes:

1. Stress greater than those listed under ABSOLUTE MAXIMUM RATINGS may cause permanent damage to the device. This is a stress rating only and functional operation of the device at these or any other conditions above those indicated in the operational sections of this specification is not implied. Exposure to absolute maximum rating conditions for extended periods may affect reliability.

## OPERATING RANGE

Range	Ambient Temperature	V <sub>DD</sub>
Commercial	0°C to +70°C	3.3V +10%, -5%
Industrial	-40°C to +85°C	3.3V +10%, -5%

CAPACITANCE<sup>(1,2)</sup>

Symbol	Parameter	Conditions	Max.	Unit
C <sub>IN</sub>	Input Capacitance	V <sub>IN</sub> = 0V	6	pF
C <sub>I/O</sub>	Input/Output Capacitance	V <sub>OUT</sub> = 0V	8	pF

## Notes:

1. Tested initially and after any design or process changes that may affect these parameters.
2. Test conditions: T<sub>A</sub> = 25°C, f = 1 MHz, V<sub>DD</sub> = 3.3V.

**DC ELECTRICAL CHARACTERISTICS** (Over Operating Range)

Symbol	Parameter	Test Conditions		Min.	Max.	Unit
V <sub>OH</sub>	Output HIGH Voltage	V <sub>DD</sub> = Min., I <sub>OH</sub> = -4.0 mA		2.4	—	V
V <sub>OL</sub>	Output LOW Voltage	V <sub>DD</sub> = Min., I <sub>OL</sub> = 8.0 mA		—	0.4	V
V <sub>IH</sub>	Input HIGH Voltage			2.2	V <sub>DD</sub> + 0.3	V
V <sub>IL</sub>	Input LOW Voltage <sup>(1)</sup>			-0.3	0.8	V
I <sub>LI</sub>	Input Leakage	GND ≤ V <sub>IN</sub> ≤ V <sub>DD</sub>	Com. Ind.	-1 -5	1 5	μA
I <sub>LO</sub>	Output Leakage	GND ≤ V <sub>OUT</sub> ≤ V <sub>DD</sub> , Outputs Disabled	Com. Ind.	-1 -5	1 5	μA

**Note:**

1. V<sub>IL</sub> = -3.0V for pulse width less than 10ns.

**POWER SUPPLY CHARACTERISTICS<sup>(1)</sup>** (Over Operating Range)

Symbol	Parameter	Test Conditions		-8		-10		Unit
				Min.	Max.	Min.	Max.	
I <sub>CC</sub>	V <sub>DD</sub> Dynamic Operating Supply Current	V <sub>DD</sub> = Max., I <sub>OUT</sub> = 0 mA, f = f <sub>MAX</sub>	Com. Ind.	— —	110 120	— —	100 110	mA
I <sub>SB1</sub>	TTL Standby Current (TTL Inputs)	V <sub>DD</sub> = Max., V <sub>IN</sub> = V <sub>IH</sub> or V <sub>IL</sub> $\overline{CE} \geq V_{IH}$ , f = 0	Com. Ind.	— —	30 35	— —	30 35	mA
I <sub>SB2</sub>	CMOS Standby Current (CMOS Inputs)	V <sub>DD</sub> = Max., $\overline{CE} \geq V_{DD} - 0.2V$ , V <sub>IN</sub> ≥ V <sub>DD</sub> - 0.2V, or V <sub>IN</sub> ≤ 0.2V, f = 0	Com. Ind.	— —	20 25	— —	20 25	mA

**Note:**

1. At f = f<sub>MAX</sub>, address and data inputs are cycling at the maximum frequency, f = 0 means no input lines change.

**AC TEST CONDITIONS**

Parameter	Unit
Input Pulse Level	0V to 3.0V
Input Rise and Fall Times	3 ns
Input and Output Timing and Reference Levels	1.5V
Output Load	See Figures 1 and 2

**AC TEST LOADS**

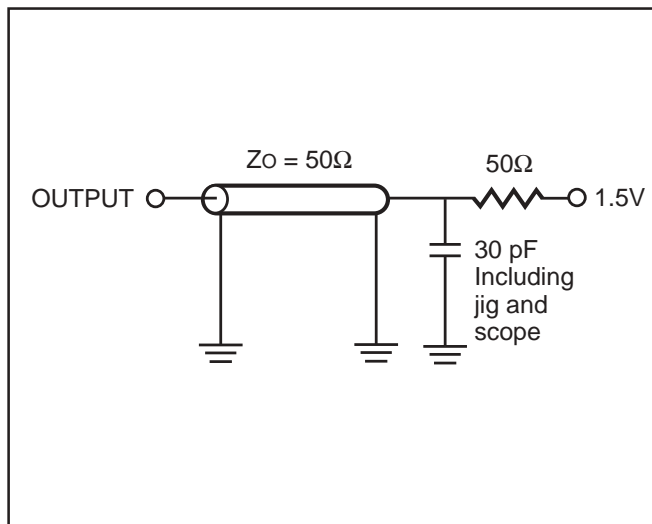

Figure 1

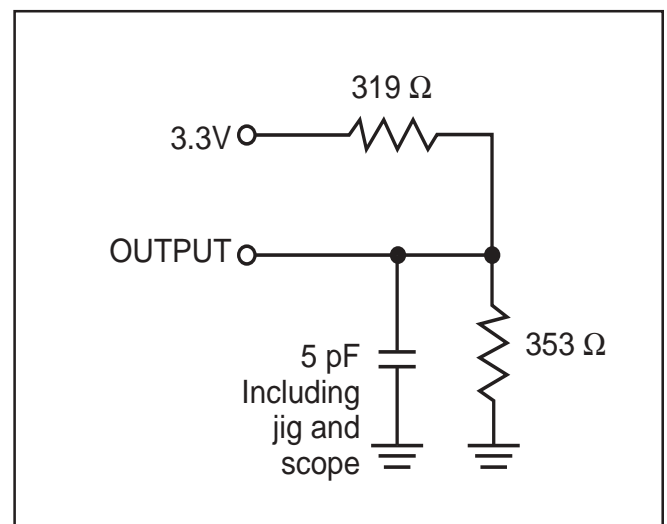

Figure 2

READ CYCLE SWITCHING CHARACTERISTICS<sup>(1)</sup> (Over Operating Range)

Symbol	Parameter	-8		-10		Unit
		Min.	Max.	Min.	Max.	
t <sub>RC</sub>	Read Cycle Time	8	—	10	—	ns
t <sub>AA</sub>	Address Access Time	—	8	—	10	ns
t <sub>OH</sub>	Output Hold Time	3	—	3	—	ns
t <sub>ACE</sub>	$\overline{\text{CE}}$ Access Time	—	8	—	10	ns
t <sub>DOE</sub>	$\overline{\text{OE}}$ Access Time	—	3.5	—	4	ns
t <sub>HZOE</sub> <sup>(2)</sup>	$\overline{\text{OE}}$ to High-Z Output	—	3	—	4	ns
t <sub>LZOE</sub> <sup>(2)</sup>	$\overline{\text{OE}}$ to Low-Z Output	0	—	0	—	ns
t <sub>HZCE</sub> <sup>(2)</sup>	$\overline{\text{CE}}$ to High-Z Output	—	3	0	4	ns
t <sub>LZCE</sub> <sup>(2)</sup>	$\overline{\text{CE}}$ to Low-Z Output	3	—	3	—	ns
t <sub>PU</sub>	Power Up Time	0	—	0	—	ns
t <sub>PD</sub>	Power Down Time	—	8	—	10	ns

**Notes:**

1. Test conditions assume signal transition times of 3 ns or less, timing reference levels of 1.5V, input pulse levels of 0V to 3.0V and output loading specified in Figure 1.
2. Tested with the load in Figure 2. Transition is measured  $\pm 500$  mV from steady-state voltage.

AC WAVEFORMS

READ CYCLE NO. 1<sup>(1,2)</sup> (Address Controlled) ( $\overline{CE} = \overline{OE} = V_{IL}$ )

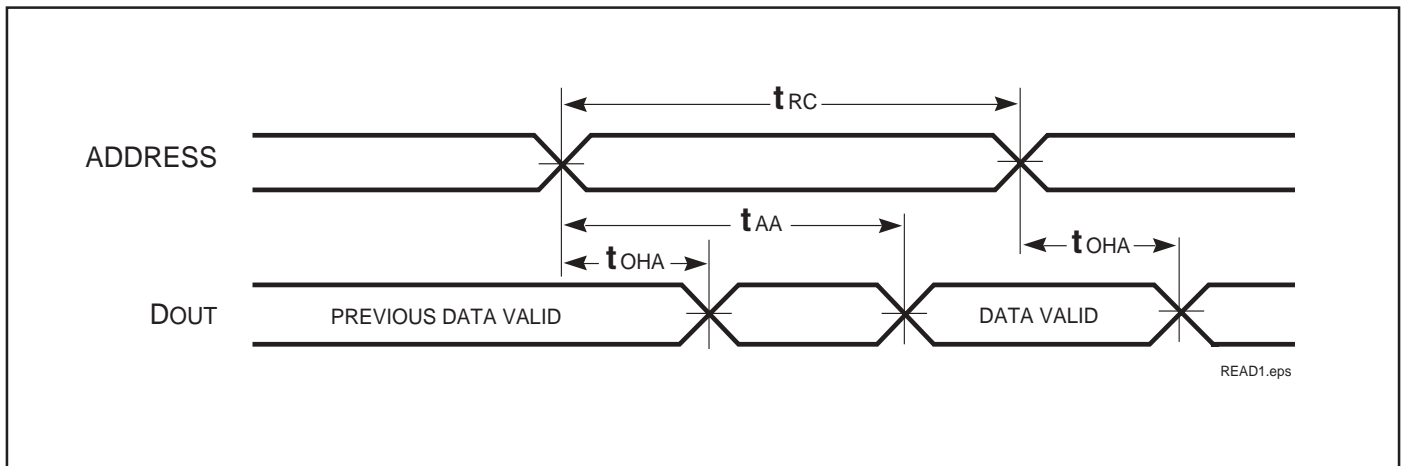

READ CYCLE NO. 2<sup>(1,3)</sup> ( $\overline{CE}$  and  $\overline{OE}$  Controlled)

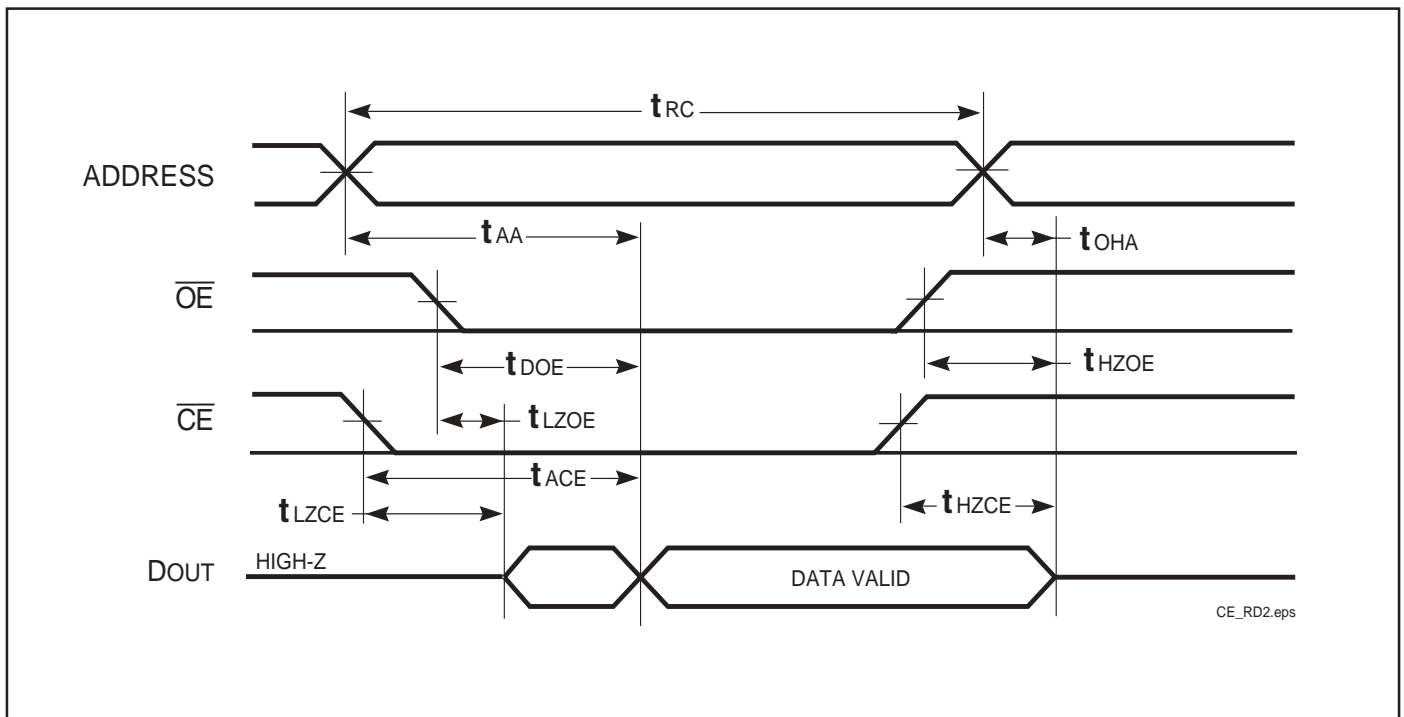

Notes:

1.  $\overline{WE}$  is HIGH for a Read Cycle.
2. The device is continuously selected.  $\overline{OE}, \overline{CE} = V_{IL}$ .
3. Address is valid prior to or coincident with  $\overline{CE}$  LOW transitions.

**WRITE CYCLE SWITCHING CHARACTERISTICS<sup>(1,3)</sup>** (Over Operating Range)

Symbol	Parameter	-8		-10		Unit
		Min.	Max.	Min.	Max.	
t <sub>WC</sub>	Write Cycle Time	8	—	10	—	ns
t <sub>SCE</sub>	$\overline{\text{CE}}$ to Write End	6.5	—	8	—	ns
t <sub>AW</sub>	Address Setup Time to Write End	6.5	—	8	—	ns
t <sub>HA</sub>	Address Hold from Write End	0	—	0	—	ns
t <sub>SA</sub>	Address Setup Time	0	—	0	—	ns
t <sub>PWE1</sub>	$\overline{\text{WE}}$ Pulse Width	6.5	—	8	—	ns
t <sub>PWE2</sub>	$\overline{\text{WE}}$ Pulse Width ( $\overline{\text{OE}} = \text{LOW}$ )	8	—	10	—	ns
t <sub>SD</sub>	Data Setup to Write End	5	—	6	—	ns
t <sub>HD</sub>	Data Hold from Write End	0	—	0	—	ns
t <sub>HZWE<sup>(2)</sup></sub>	$\overline{\text{WE}}$ LOW to High-Z Output	—	3.5	—	5	ns
t <sub>LZWE<sup>(2)</sup></sub>	$\overline{\text{WE}}$ HIGH to Low-Z Output	2	—	2	—	ns

**Notes:**

1. Test conditions assume signal transition times of 3 ns or less, timing reference levels of 1.5V, input pulse levels of 0V to 3.0V and output loading specified in Figure 1.
2. Tested with the load in Figure 2. Transition is measured  $\pm 500$  mV from steady-state voltage. Not 100% tested.
3. The internal write time is defined by the overlap of  $\overline{\text{CE}}$  LOW and  $\overline{\text{WE}}$  LOW. All signals must be in valid states to initiate a Write, but any one can go inactive to terminate the Write. The Data Input Setup and Hold timing are referenced to the rising or falling edge of the signal that terminates the write.

AC WAVEFORMS

WRITE CYCLE NO. 1<sup>(1,2)</sup> ( $\overline{CE}$  Controlled,  $\overline{OE}$  = HIGH or LOW)

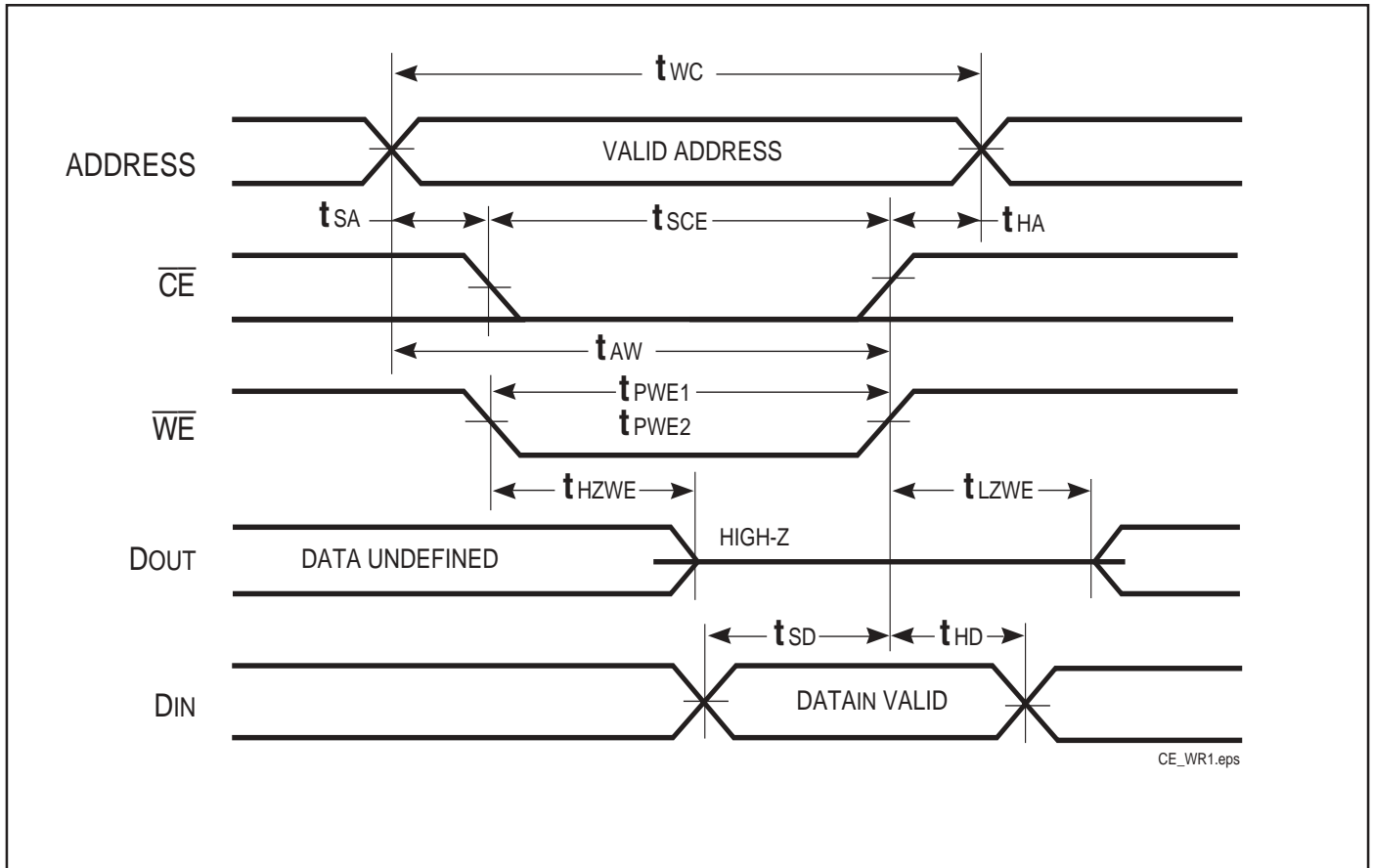

AC WAVEFORMS

WRITE CYCLE NO. 2<sup>(1,2)</sup> ( $\overline{WE}$  Controlled:  $\overline{OE}$  is HIGH During Write Cycle)

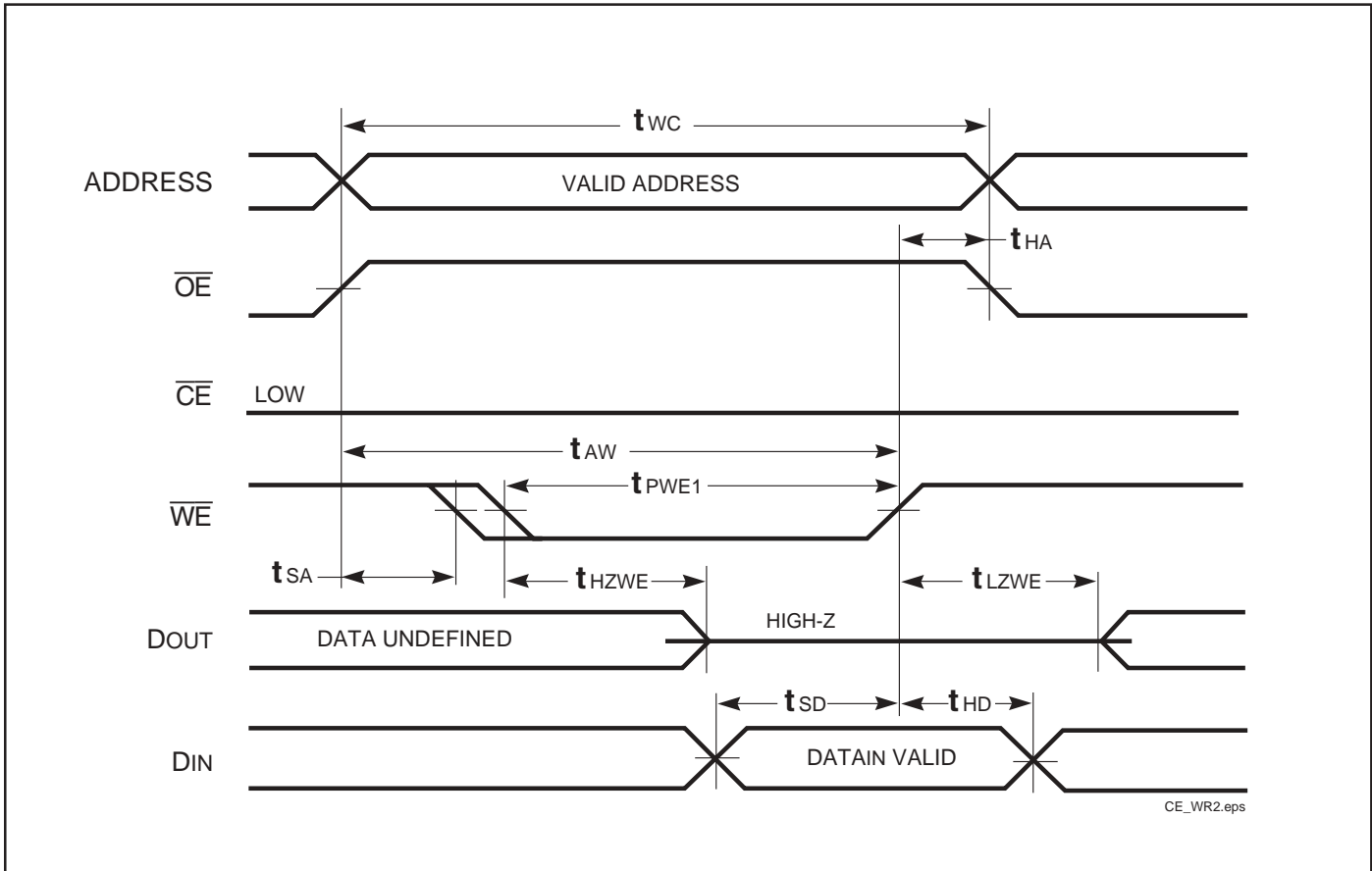

Notes:

1. The internal write time is defined by the overlap of  $\overline{CE}$  LOW and  $\overline{WE}$  LOW. All signals must be in valid states to initiate a Write, but any one can go inactive to terminate the Write. The Data Input Setup and Hold timing are referenced to the rising or falling edge of the signal that terminates the Write.
2. I/O will assume the High-Z state if  $\overline{OE} > V_{IH}$ .

AC WAVEFORMS

WRITE CYCLE NO. 3 ( $\overline{WE}$  Controlled:  $\overline{OE}$  is LOW During Write Cycle)

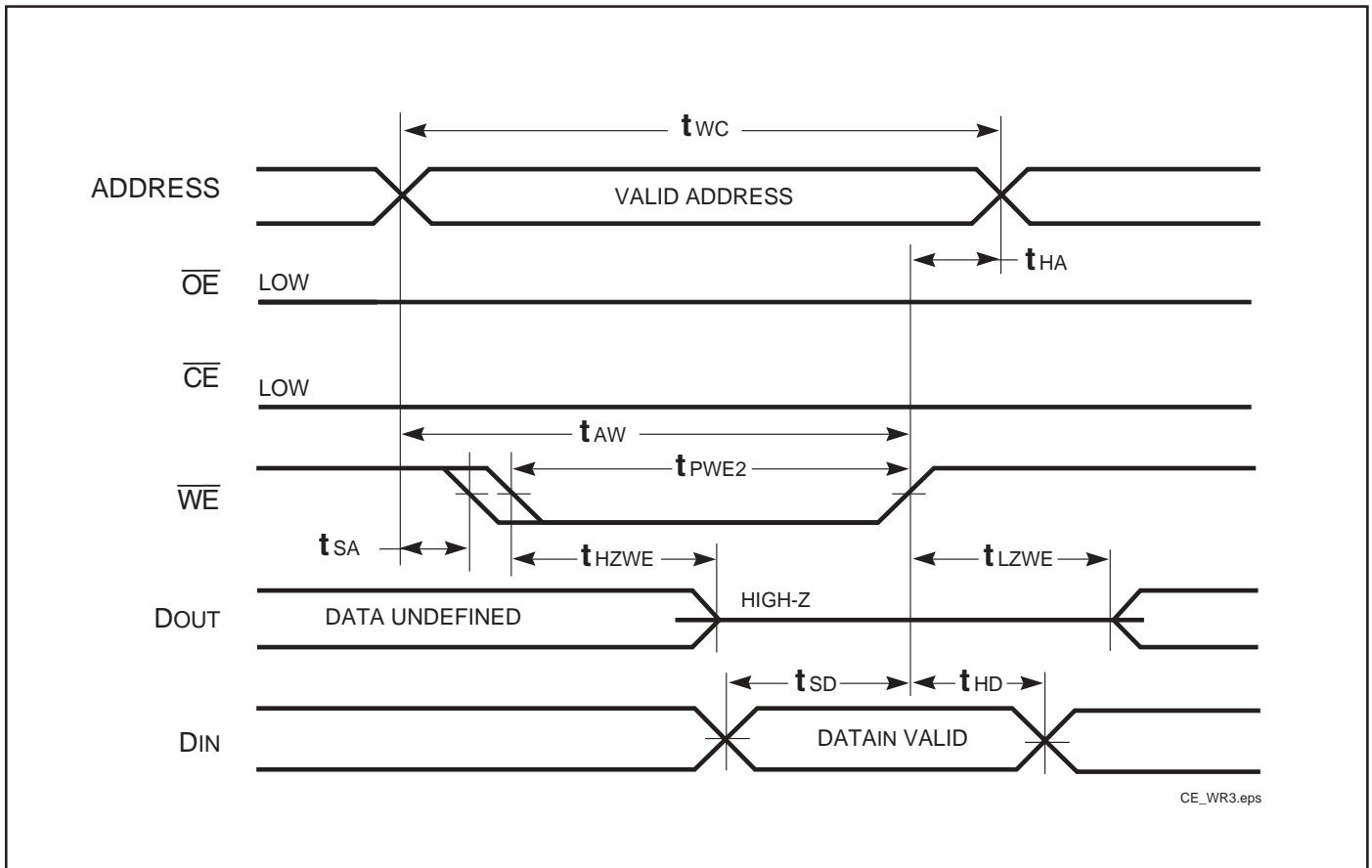

## ORDERING INFORMATION

## Commercial Range: 0°C to +70°C

Speed (ns)	Order Part No.	Package
8	IS61LV10248-8M	48 mini BGA (9mm x 11mm)
	IS61LV10248-8T	TSOP (Type II)
	IS61LV10248-8B	36 mini BGA (9mm x 11mm)
10	IS61LV10248-10T	TSOP (Type II)

## Industrial Range: -40°C to +85°C

Speed (ns)	Order Part No.	Package
8	IS61LV10248-8MI	48 mini BGA (9mm x 11mm)
	IS61LV10248-8TI	TSOP (Type II)
	IS61LV10248-8BI	36 mini BGA (9mm x 11mm)
10	IS61LV10248-10MI	48 mini BGA (9mm x 11mm)
	IS61LV10248-10TI	TSOP (Type II)
	IS61LV10248-10TLI	TSOP (Type II), Lead-free
	IS61LV10248-10BI	36 mini BGA (9mm x 11mm)

**Mini Ball Grid Array  
Package Code: B (36-pin)**

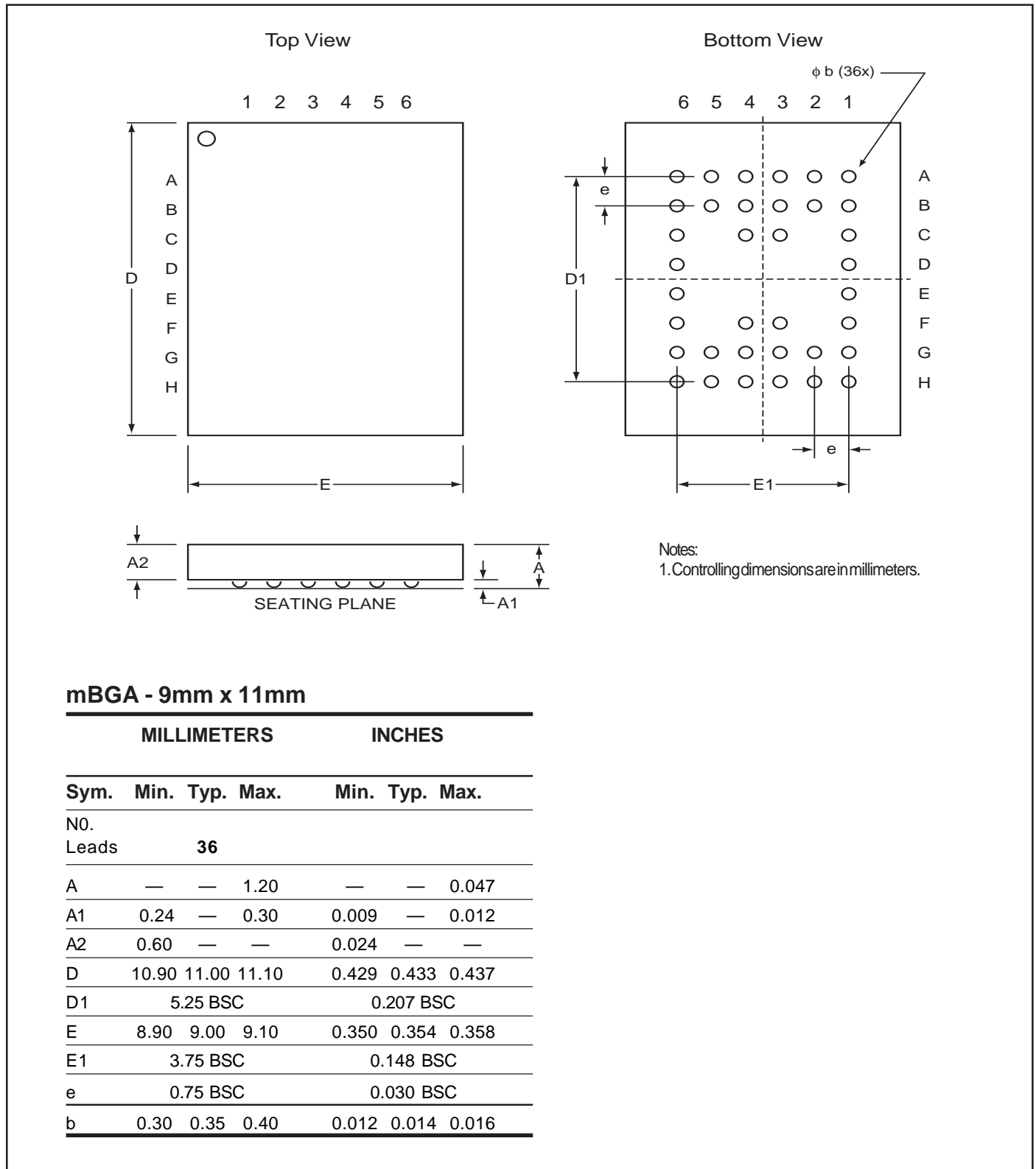

# PACKAGING INFORMATION

## Mini Ball Grid Array Package Code: M (48-pin)

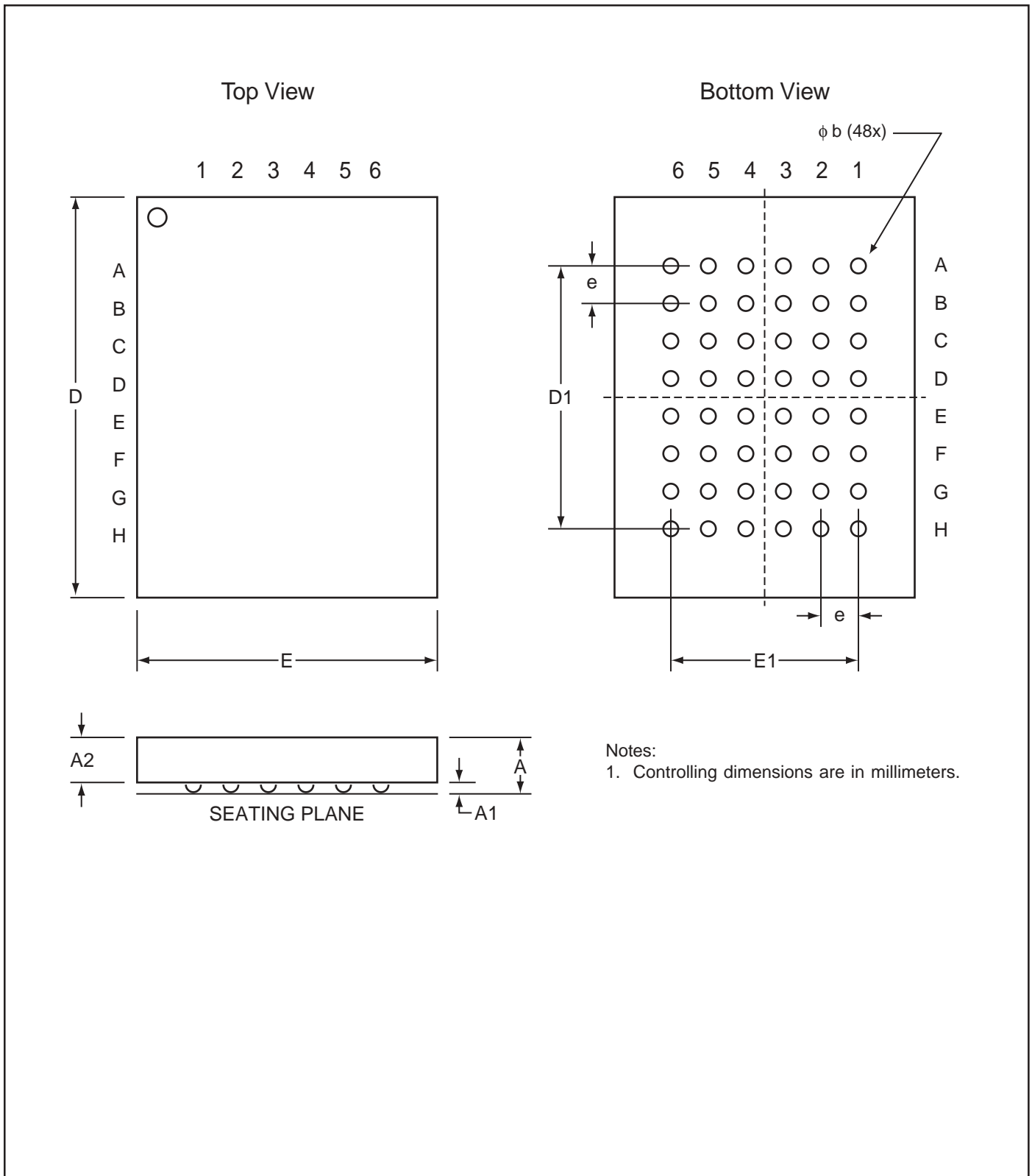

Copyright © 2003 Integrated Silicon Solution, Inc. All rights reserved. ISSI reserves the right to make changes to this specification and its products at any time without notice. ISSI assumes no liability arising out of the application or use of any information, products or services described herein. Customers are advised to obtain the latest version of this device specification before relying on any published information and before placing orders for products.

# PACKAGING INFORMATION



## Mini Ball Grid Array Package Code: M (48-pin)

### mBGA - 6mm x 8mm

MILLIMETERS				INCHES		
Sym.	Min.	Typ.	Max.	Min.	Typ.	Max.
NO. Leads		<b>48</b>				
A	—	—	1.20	—	—	0.047
A1	0.25	—	0.40	0.010	—	0.016
A2	0.60	—	—	0.024	—	—
D	7.90	8.00	8.10	0.311	0.314	0.319
D1	5.60BSC			0.220BSC		
E	5.90	6.00	6.10	0.232	0.236	0.240
E1	4.00BSC			0.157BSC		
e	0.80BSC			0.031BSC		
b	0.40	0.45	0.50	0.016	0.018	0.020

### mBGA - 7.2mm x 8.7mm

MILLIMETERS				INCHES		
Sym.	Min.	Typ.	Max.	Min.	Typ.	Max.
NO. Leads		<b>48</b>				
A	—	—	1.20	—	—	0.047
A1	0.24	—	0.30	0.009	—	0.012
A2	0.60	—	—	0.024	—	—
D	8.60	8.70	8.80	0.339	0.343	0.346
D1	5.25BSC			0.207BSC		
E	7.10	7.20	7.30	0.280	0.283	0.287
E1	3.75BSC			0.148BSC		
e	0.75BSC			0.030BSC		
b	0.30	0.35	0.40	0.012	0.014	0.016

### mBGA - 9mm x 11mm

MILLIMETERS				INCHES		
Sym.	Min.	Typ.	Max.	Min.	Typ.	Max.
NO. Leads		<b>48</b>				
A	—	—	1.20	—	—	0.047
A1	0.24	—	0.30	0.009	—	0.012
A2	0.60	—	—	0.024	—	—
D	10.90	11.00	11.10	0.429	0.433	0.437
D1	5.25BSC			0.207BSC		
E	8.90	9.00	9.10	0.350	0.354	0.358
E1	3.75BSC			0.148BSC		
e	0.75BSC			0.030BSC		
b	0.30	0.35	0.40	0.012	0.014	0.016

# PACKAGING INFORMATION



## Plastic TSOP Package Code: T (Type II)

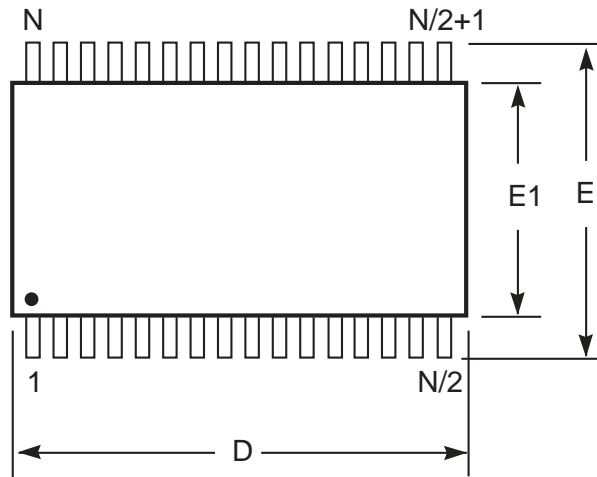

### Notes:

1. Controlling dimension: millimeters, unless otherwise specified.
2. BSC = Basic lead spacing between centers.
3. Dimensions D and E1 do not include mold flash protrusions and should be measured from the bottom of the package.
4. Formed leads shall be planar with respect to one another within 0.004 inches at the seating plane.

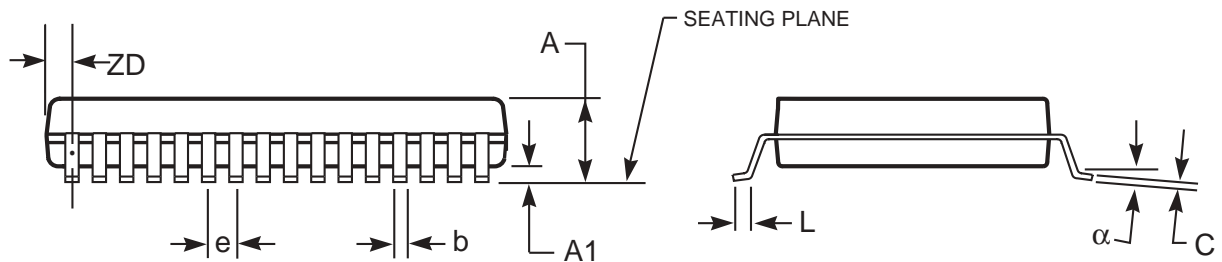

Plastic TSOP (T - Type II)

Symbol	Millimeters		Inches		Millimeters		Inches		Millimeters		Inches	
	Min	Max	Min	Max	Min	Max	Min	Max	Min	Max	Min	Max
Ref. Std.												
No. Leads (N)	32				44				50			
A	—	1.20	—	0.047	—	1.20	—	0.047	—	1.20	—	0.047
A1	0.05	0.15	0.002	0.006	0.05	0.15	0.002	0.006	0.05	0.15	0.002	0.006
b	0.30	0.52	0.012	0.020	0.30	0.45	0.012	0.018	0.30	0.45	0.012	0.018
C	0.12	0.21	0.005	0.008	0.12	0.21	0.005	0.008	0.12	0.21	0.005	0.008
D	20.82	21.08	0.820	0.830	18.31	18.52	0.721	0.729	20.82	21.08	0.820	0.830
E1	10.03	10.29	0.391	0.400	10.03	10.29	0.395	0.405	10.03	10.29	0.395	0.405
E	11.56	11.96	0.451	0.466	11.56	11.96	0.455	0.471	11.56	11.96	0.455	0.471
e	1.27 BSC		0.050 BSC		0.80 BSC		0.032 BSC		0.80 BSC		0.031 BSC	
L	0.40	0.60	0.016	0.024	0.41	0.60	0.016	0.024	0.40	0.60	0.016	0.024
ZD	0.95 REF		0.037 REF		0.81 REF		0.032 REF		0.88 REF		0.035 REF	
α	0°	5°	0°	5°	0°	5°	0°	5°	0°	5°	0°	5°

Copyright © 2003 Integrated Silicon Solution, Inc. All rights reserved. ISSI reserves the right to make changes to this specification and its products at any time without notice. ISSI assumes no liability arising out of the application or use of any information, products or services described herein. Customers are advised to obtain the latest version of this device specification before relying on any published information and before placing orders for products.