

BC337/BC338 TRANSISTOR (NPN)

FEATURES

- Power dissipation

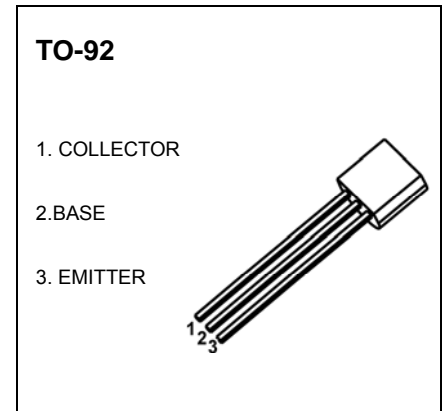

MARKING

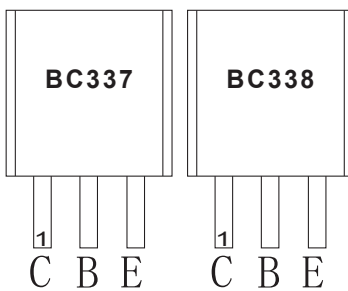

BC337,BC338=Device code
Solid dot=Green molding compound device,
if none,the normal device

Equivalent Circuit

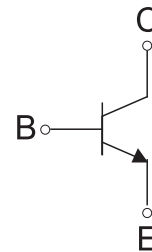

ORDERING INFORMATION

Part Number	Package	Packing Method	Pack Quantity
BC337	TO-92	Bulk	1000pcs/Bag
BC337-TA	TO-92	Tape	2000pcs/Box
BC338	TO-92	Bulk	1000pcs/Bag
BC338-TA	TO-92	Tape	2000pcs/Box

MAXIMUM RATINGS (T_a=25°C unless otherwise noted)

Symbol	Parameter	Value	Unit
V _{CBO}	Collector-Base Voltage	BC337	50
		BC338	30
V _{CEO}	Collector-Emitter Voltage	BC337	45
		BC338	25
V _{EBO}	Emitter-Base Voltage	5	V
I _C	Collector Current -Continuous	800	mA
P _D	Total Device Dissipation	625	mW
T _j	Junction Temperature	150	°C
T _{stg}	Storage Temperature	-55-150	°C

ELECTRICAL CHARACTERISTICS

 $T_a=25^\circ\text{C}$ unless otherwise specified

Parameter	Symbol	Test conditions	MIN	TYP	MAX	UNIT
Collector-base breakdown voltage BC337 BC338	V_{CBO}	$I_C=100\mu\text{A}, I_E=0$	50 30			V V
Collector-emitter breakdown voltage BC337 BC338	V_{CEO}	$I_C=10\text{mA}, I_B=0$	45 25			V V
Emitter-base breakdown voltage	V_{EBO}	$I_E=10\mu\text{A}, I_C=0$	5			V
Collector cut-off current BC337 BC338	I_{CBO}	$V_{CB}=45\text{V}, I_E=0$ $V_{CB}=25\text{V}, I_E=0$			0.1 0.1	μA
Collector cut-off current BC337 BC338	I_{CEO}	$V_{CE}=40\text{V}, I_B=0$ $V_{CE}=20\text{V}, I_B=0$			0.2 0.2	μA
Emitter cut-off current	I_{EBO}	$V_{EB}=4\text{V}, I_C=0$			0.1	μA
BC337/BC338 BC337-16/BC338-16 BC337-25/BC338-25 BC337-40/BC338-40	$h_{FE(1)}$	$V_{CE}=1\text{V}, I_C=100\text{mA}$	100 100 160 250		630 250 400 630	
DC current gain	$h_{FE(2)}$	$V_{CE}=1\text{V}, I_C=300\text{mA}$	60			
Collector-emitter saturation voltage	$V_{CE(sat)}$	$I_C=500\text{mA}, I_B=50\text{mA}$			0.7	V
Base-emitter saturation voltage	$V_{BE(sat)}$	$I_C=500\text{mA}, I_B=50\text{mA}$			1.2	V
Base-emitter voltage	V_{BE}	$V_{CE}=1\text{V}, I_C=300\text{mA}$			1.2	V
Transition frequency	f_T	$V_{CE}=5\text{V}, I_C=10\text{mA}$ $f=100\text{MHz}$	210			MHz
Collector Output Capacitance	C_{ob}	$V_{CB}=10\text{V}, I_E=0$ $f=1\text{MHz}$		15		pF

Typical Characteristics

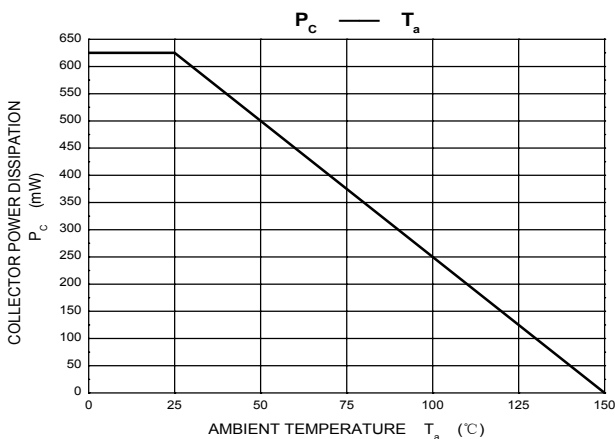
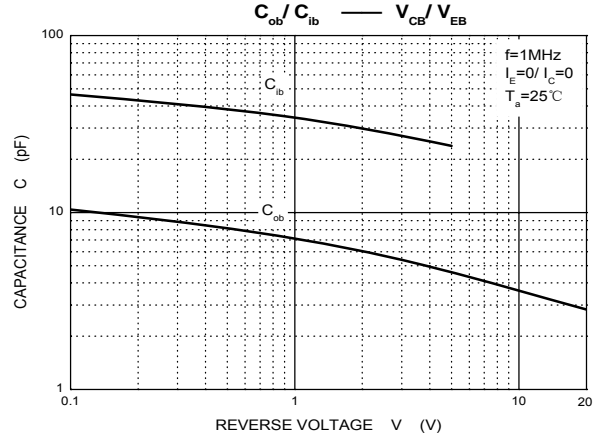
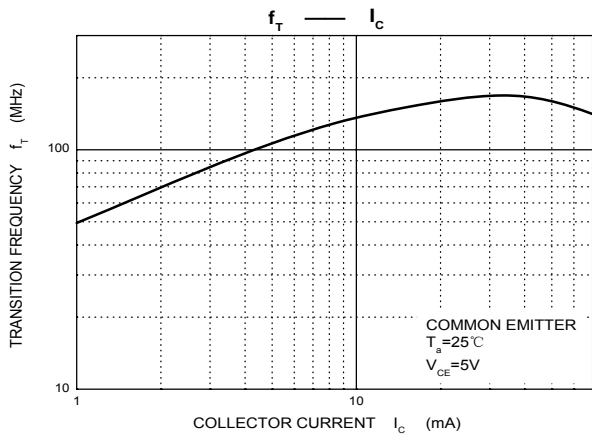
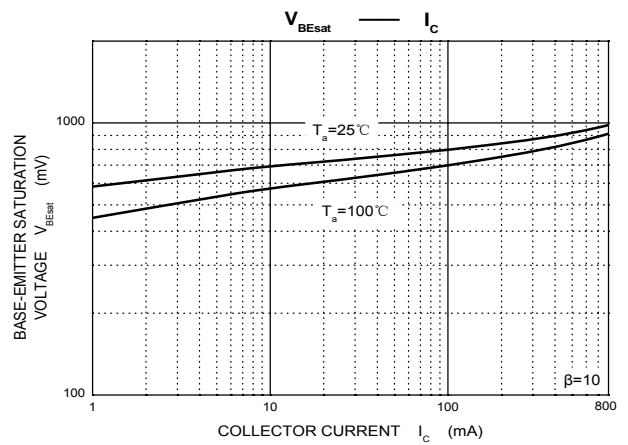
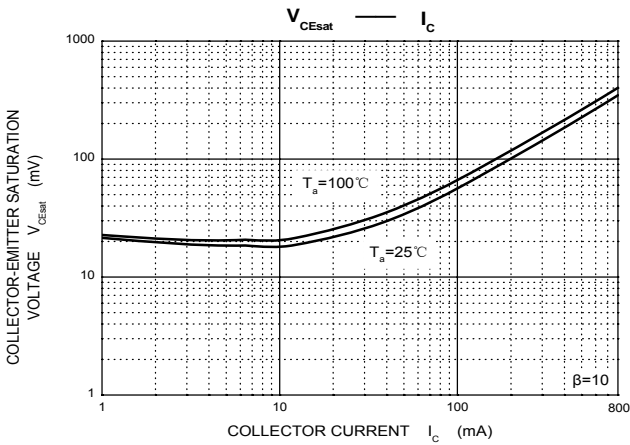
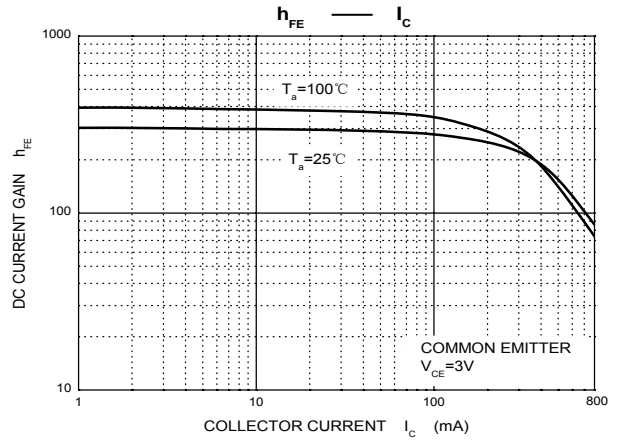
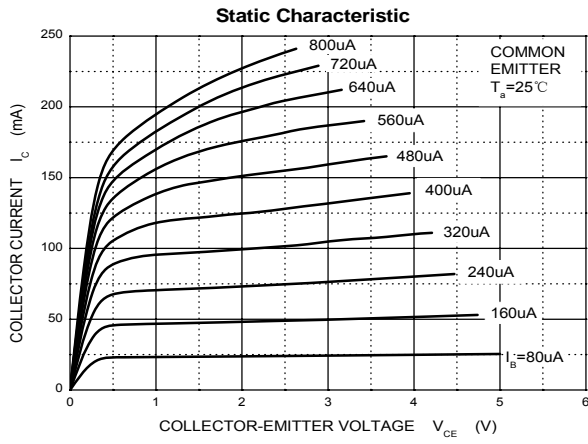

TO-92 Package Outline Dimensions

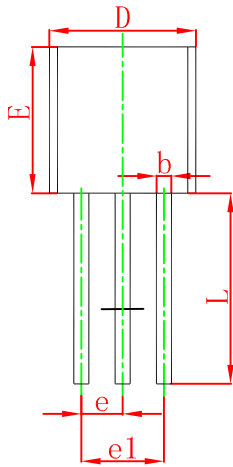
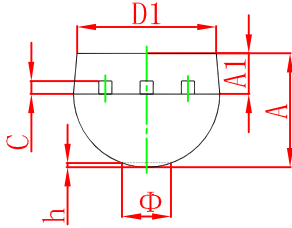

Symbol	Dimensions In Millimeters		Dimensions In Inches	
	Min	Max	Min	Max
A	3.300	3.700	0.130	0.146
A1	1.100	1.400	0.043	0.055
b	0.380	0.550	0.015	0.022
c	0.360	0.510	0.014	0.020
D	4.300	4.700	0.169	0.185
D1	3.430		0.135	
E	4.300	4.700	0.169	0.185
e	1.270 TYP		0.050 TYP	
e1	2.440	2.640	0.096	0.104
L	14.100	14.500	0.555	0.571
Φ		1.600		0.063
h	0.000	0.380	0.000	0.015

TO-92 Suggested Pad Layout

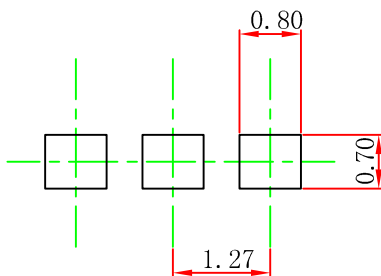

Note:

1. Controlling dimension: in millimeters.
2. General tolerance: $\pm 0.05\text{mm}$.
3. The pad layout is for reference purposes only.