

Fast IGBT in NPT-technology with soft, fast recovery anti-parallel EmCon diode

- 75% lower E_{off} compared to previous generation combined with low conduction losses
- Short circuit withstand time – 10 μ s
- Designed for:
 - Motor controls
 - Inverter
- NPT-Technology for 600V applications offers:
 - very tight parameter distribution
 - high ruggedness, temperature stable behaviour
 - parallel switching capability
- Very soft, fast recovery anti-parallel EmCon diode
- Complete product spectrum and PSpice Models : <http://www.infineon.com/igbt/>

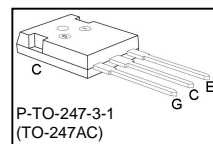
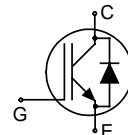

| Type | V_{CE} | I_C | $V_{CE(sat)}$ | T_j | Package | Ordering Code |
|----------|----------|-------|---------------|-------|----------|---------------|
| SKW30N60 | 600V | 30A | 2.5V | 150°C | TO-247AC | Q67040-S4244 |

Maximum Ratings

| Parameter | Symbol | Value | Unit |
|--|----------------|------------|---------|
| Collector-emitter voltage | V_{CE} | 600 | V |
| DC collector current | I_C | 41 | A |
| $T_C = 25^\circ\text{C}$ | | 30 | |
| $T_C = 100^\circ\text{C}$ | | | |
| Pulsed collector current, t_p limited by T_{jmax} | I_{Cpuls} | 112 | |
| Turn off safe operating area | - | 112 | |
| $V_{CE} \leq 600\text{V}, T_j \leq 150^\circ\text{C}$ | | | |
| Diode forward current | I_F | 41 | |
| $T_C = 25^\circ\text{C}$ | | 30 | |
| $T_C = 100^\circ\text{C}$ | | | |
| Diode pulsed current, t_p limited by T_{jmax} | I_{Fpuls} | 112 | |
| Gate-emitter voltage | V_{GE} | ± 20 | V |
| Short circuit withstand time ¹⁾ | t_{SC} | 10 | μ s |
| $V_{GE} = 15\text{V}, V_{CC} \leq 600\text{V}, T_j \leq 150^\circ\text{C}$ | | | |
| Power dissipation | P_{tot} | 250 | W |
| $T_C = 25^\circ\text{C}$ | | | |
| Operating junction and storage temperature | T_j, T_{stg} | -55...+150 | °C |

¹⁾ Allowed number of short circuits: <1000; time between short circuits: >1s.

Thermal Resistance

| Parameter | Symbol | Conditions | Max. Value | Unit |
|---|-------------|------------|------------|------|
| Characteristic | | | | |
| IGBT thermal resistance, junction – case | R_{thJC} | | 0.5 | K/W |
| Diode thermal resistance, junction – case | R_{thJCD} | | 1 | |
| Thermal resistance, junction – ambient | R_{thJA} | TO-247AC | 40 | |

Electrical Characteristic, at $T_j = 25^\circ\text{C}$, unless otherwise specified

| Parameter | Symbol | Conditions | Value | | | Unit |
|--|---------------|---|----------|-------------|-------------|---------|
| | | | min. | Typ. | max. | |
| Static Characteristic | | | | | | |
| Collector-emitter breakdown voltage | $V_{(BR)CES}$ | $V_{GE}=0V, I_C=500\mu A$ | 600 | - | - | V |
| Collector-emitter saturation voltage | $V_{CE(sat)}$ | $V_{GE} = 15V, I_C=30A$ $T_j=25^\circ\text{C}$ $T_j=150^\circ\text{C}$ | 1.7 - | 2.1 2.5 | 2.4 3.0 | |
| Diode forward voltage | V_F | $V_{GE}=0V, I_F=30A$ $T_j=25^\circ\text{C}$ $T_j=150^\circ\text{C}$ | 1.2 - | 1.4 1.25 | 1.8 1.65 | |
| Gate-emitter threshold voltage | $V_{GE(th)}$ | $I_C=700\mu A, V_{CE}=V_{GE}$ | 3 | 4 | 5 | |
| Zero gate voltage collector current | I_{CES} | $V_{CE}=600V, V_{GE}=0V$ $T_j=25^\circ\text{C}$ $T_j=150^\circ\text{C}$ | - - | - - | 40 3000 | μA |
| Gate-emitter leakage current | I_{GES} | $V_{CE}=0V, V_{GE}=20V$ | - | - | 100 | nA |
| Transconductance | g_{fs} | $V_{CE}=20V, I_C=30A$ | - | 20 | - | S |
| Dynamic Characteristic | | | | | | |
| Input capacitance | C_{iss} | $V_{CE}=25V,$ $V_{GE}=0V,$ $f=1\text{MHz}$ | - | 1600 | 1920 | pF |
| Output capacitance | C_{oss} | | - | 150 | 180 | |
| Reverse transfer capacitance | C_{riss} | | - | 92 | 110 | |
| Gate charge | Q_{Gate} | $V_{CC}=480V, I_C=30A$ $V_{GE}=15V$ | - | 140 | 182 | nC |
| Internal emitter inductance measured 5mm (0.197 in.) from case | L_E | TO-247AC | - | 13 | - | nH |
| Short circuit collector current ¹⁾ | $I_{C(SC)}$ | $V_{GE}=15V, t_{SC}\leq 10\mu s$ $V_{CC}\leq 600V,$ $T_j\leq 150^\circ\text{C}$ | - | 300 | - | A |

¹⁾ Allowed number of short circuits: <1000; time between short circuits: >1s.

Switching Characteristic, Inductive Load, at $T_j=25^\circ\text{C}$

| Parameter | Symbol | Conditions | Value | | | Unit |
|----------------------------|--------------|--|-------|------|------|------|
| | | | min. | typ. | max. | |
| IGBT Characteristic | | | | | | |
| Turn-on delay time | $t_{d(on)}$ | $T_j=25^\circ\text{C}$, $V_{CC}=400\text{V}$, $I_C=30\text{A}$, $V_{GE}=0/15\text{V}$, $R_G=11\Omega$, $L_{\sigma}^{1)}=180\text{nH}$, $C_{\sigma}^{1)}=900\text{pF}$ Energy losses include "tail" and diode reverse recovery. | - | 44 | 53 | ns |
| Rise time | t_r | | - | 34 | 40 | |
| Turn-off delay time | $t_{d(off)}$ | | - | 291 | 349 | |
| Fall time | t_f | | - | 58 | 70 | |
| Turn-on energy | E_{on} | | - | 0.64 | 0.77 | mJ |
| Turn-off energy | E_{off} | | - | 0.65 | 0.85 | |
| Total switching energy | E_{ts} | | - | 1.29 | 1.62 | |

Anti-Parallel Diode Characteristic

| | | | | | | |
|--|--------------|---|-----|-----|------------------|----|
| Diode reverse recovery time | t_{rr} | $T_j=25^\circ\text{C}$, $V_R=200\text{V}$, $I_F=30\text{A}$, $di_F/dt=200\text{A}/\mu\text{s}$ | - | 400 | - | ns |
| | t_S | | - | 32 | - | |
| | t_F | | - | 368 | - | |
| Diode reverse recovery charge | Q_{rr} | | - | 610 | - | nC |
| Diode peak reverse recovery current | I_{rrm} | | - | 5.5 | - | A |
| Diode peak rate of fall of reverse recovery current during t_b | di_{rr}/dt | - | 180 | - | A/ μs | |

Switching Characteristic, Inductive Load, at $T_j=150^\circ\text{C}$

| Parameter | Symbol | Conditions | Value | | | Unit |
|----------------------------|--------------|---|-------|------|------|------|
| | | | min. | typ. | max. | |
| IGBT Characteristic | | | | | | |
| Turn-on delay time | $t_{d(on)}$ | $T_j=150^\circ\text{C}$ $V_{CC}=400\text{V}$, $I_C=30\text{A}$, $V_{GE}=0/15\text{V}$, $R_G=11\Omega$, $L_{\sigma}^{1)}=180\text{nH}$, $C_{\sigma}^{1)}=900\text{pF}$ Energy losses include "tail" and diode reverse recovery. | - | 44 | 53 | ns |
| Rise time | t_r | | - | 34 | 40 | |
| Turn-off delay time | $t_{d(off)}$ | | - | 324 | 389 | |
| Fall time | t_f | | - | 67 | 80 | |
| Turn-on energy | E_{on} | | - | 0.98 | 1.18 | mJ |
| Turn-off energy | E_{off} | | - | 0.92 | 1.19 | |
| Total switching energy | E_{ts} | | - | 1.90 | 2.38 | |

Anti-Parallel Diode Characteristic

| | | | | | | |
|--|--------------|--|-----|------|------------------|----|
| Diode reverse recovery time | t_{rr} | $T_j=150^\circ\text{C}$ $V_R=200\text{V}$, $I_F=30\text{A}$, $di_F/dt=200\text{A}/\mu\text{s}$ | - | 520 | - | ns |
| | t_S | | - | 56 | - | |
| | t_F | | - | 464 | - | |
| Diode reverse recovery charge | Q_{rr} | | - | 1740 | - | nC |
| Diode peak reverse recovery current | I_{rrm} | | - | 9.0 | - | A |
| Diode peak rate of fall of reverse recovery current during t_b | di_{rr}/dt | - | 200 | - | A/ μs | |

¹⁾ Leakage inductance L_{σ} and Stray capacity C_{σ} due to dynamic test circuit in Figure E.

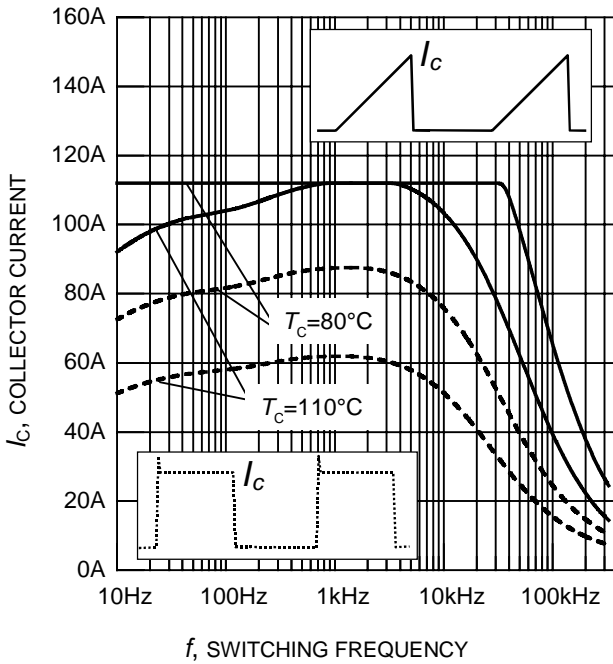

Figure 1. Collector current as a function of switching frequency
 ($T_j \leq 150^\circ\text{C}$, $D = 0.5$, $V_{CE} = 400\text{V}$,
 $V_{GE} = 0/+15\text{V}$, $R_G = 11\Omega$)

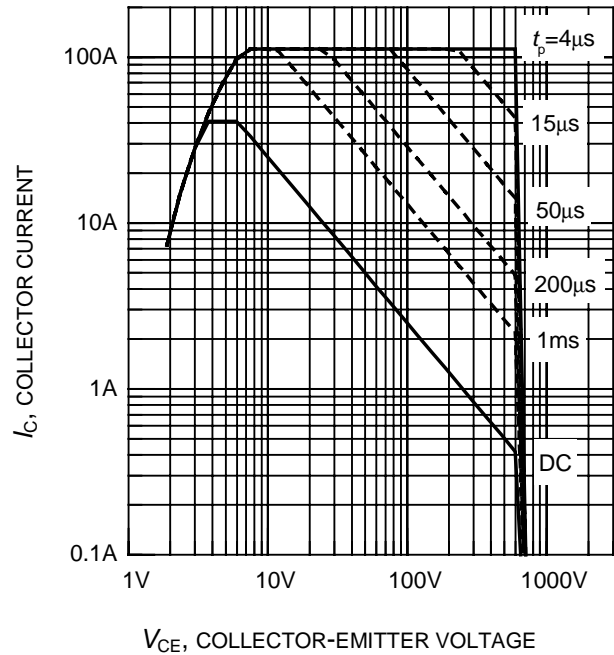

Figure 2. Safe operating area
 ($D = 0$, $T_C = 25^\circ\text{C}$, $T_j \leq 150^\circ\text{C}$)

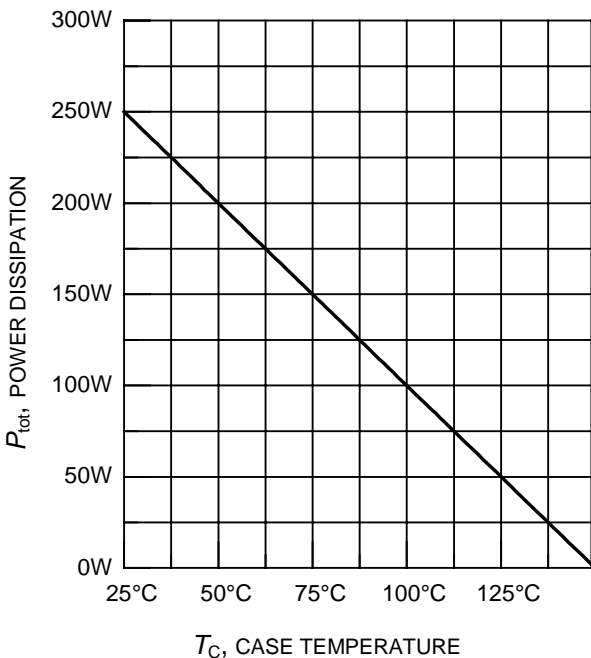

Figure 3. Power dissipation as a function of case temperature
 ($T_j \leq 150^\circ\text{C}$)

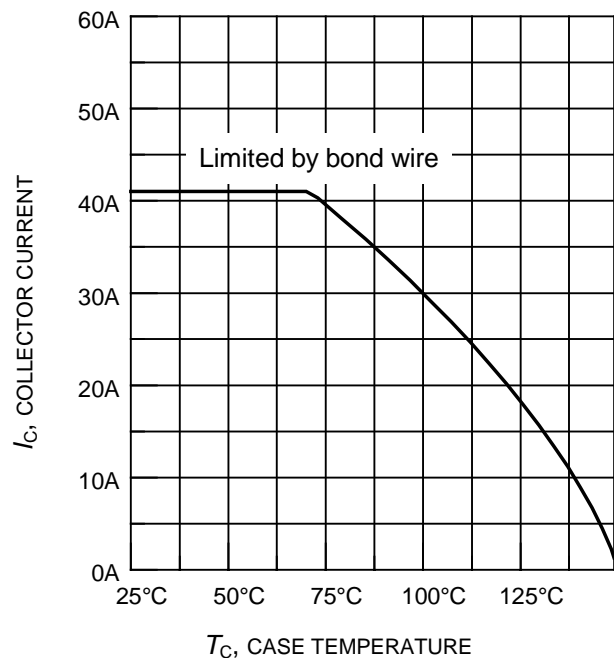

Figure 4. Collector current as a function of case temperature
 ($V_{GE} \leq 15\text{V}$, $T_j \leq 150^\circ\text{C}$)

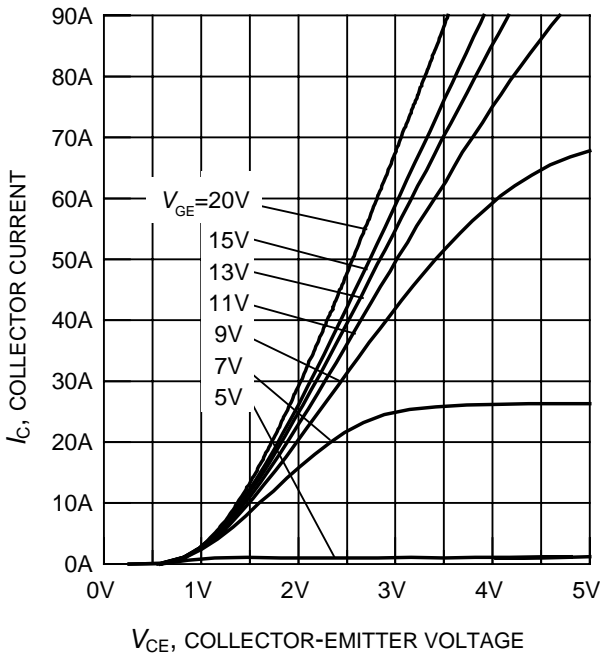

Figure 5. Typical output characteristics
($T_j = 25^\circ\text{C}$)

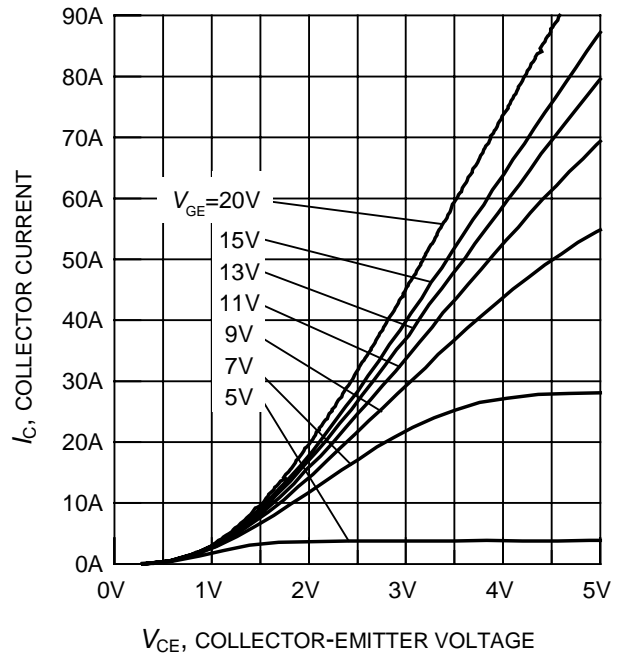

Figure 6. Typical output characteristics
($T_j = 150^\circ\text{C}$)

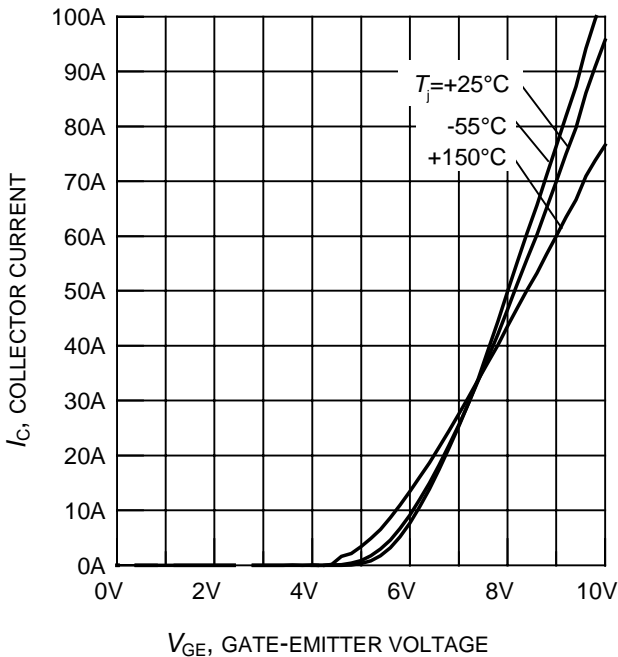

Figure 7. Typical transfer characteristics
($V_{CE} = 10\text{V}$)

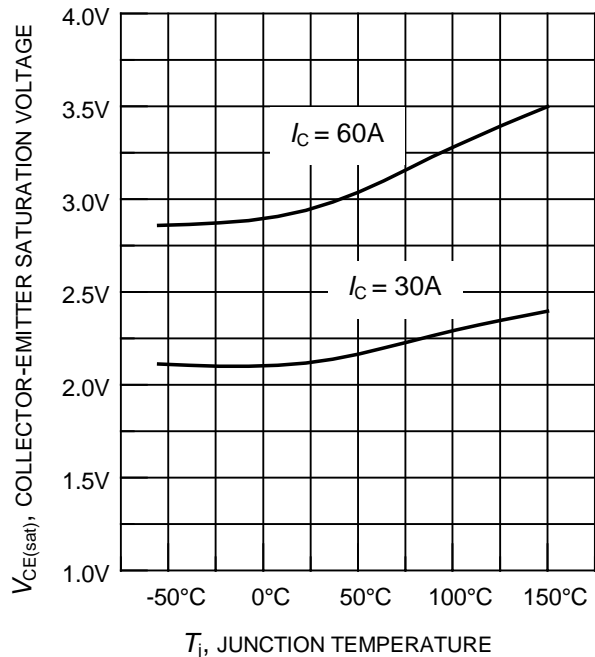

Figure 8. Typical collector-emitter saturation voltage as a function of junction temperature
($V_{GE} = 15\text{V}$)

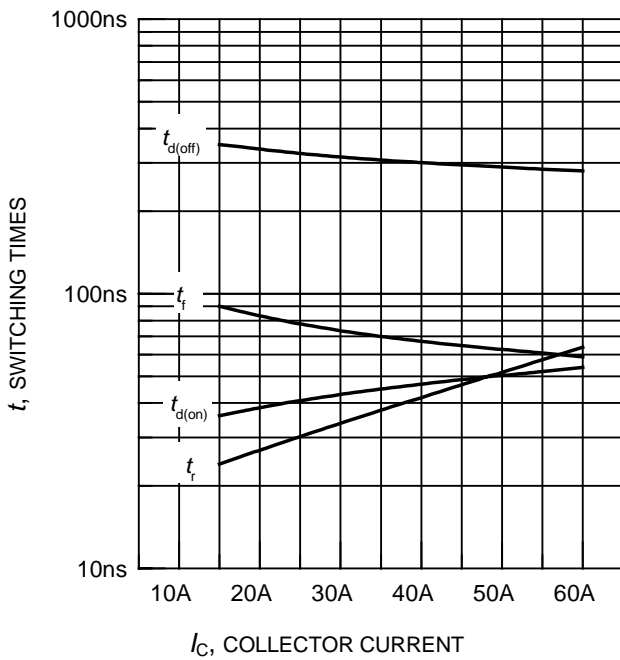

Figure 9. Typical switching times as a function of collector current
 (inductive load, $T_j = 150^\circ\text{C}$, $V_{CE} = 400\text{V}$,
 $V_{GE} = 0/+15\text{V}$, $R_G = 11\Omega$,
 Dynamic test circuit in Figure E)

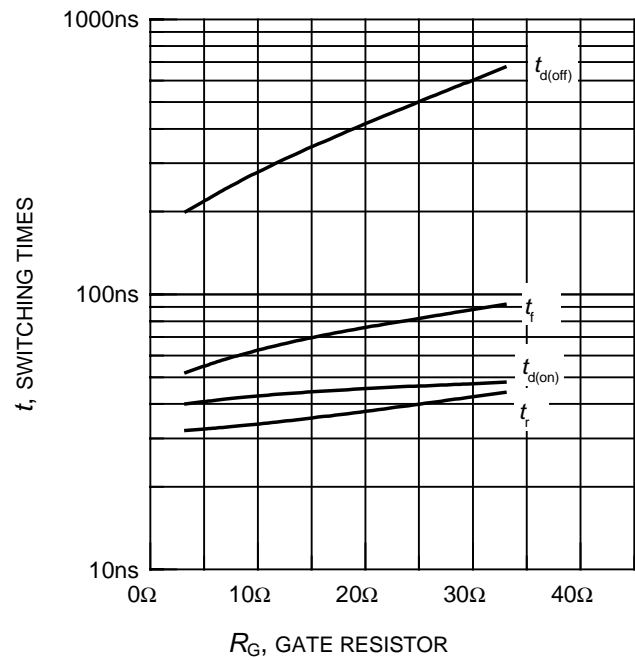

Figure 10. Typical switching times as a function of gate resistor
 (inductive load, $T_j = 150^\circ\text{C}$, $V_{CE} = 400\text{V}$,
 $V_{GE} = 0/+15\text{V}$, $I_C = 30\text{A}$,
 Dynamic test circuit in Figure E)

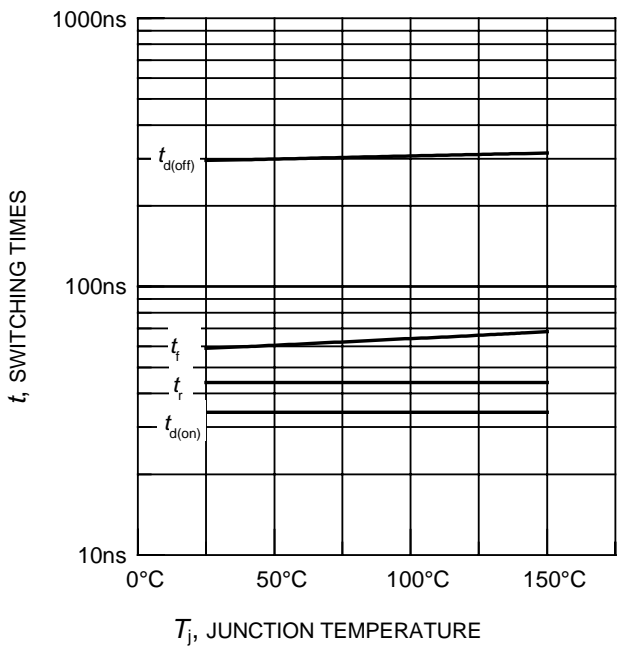

Figure 11. Typical switching times as a function of junction temperature
 (inductive load, $V_{CE} = 400\text{V}$, $V_{GE} = 0/+15\text{V}$,
 $I_C = 30\text{A}$, $R_G = 11\Omega$,
 Dynamic test circuit in Figure E)

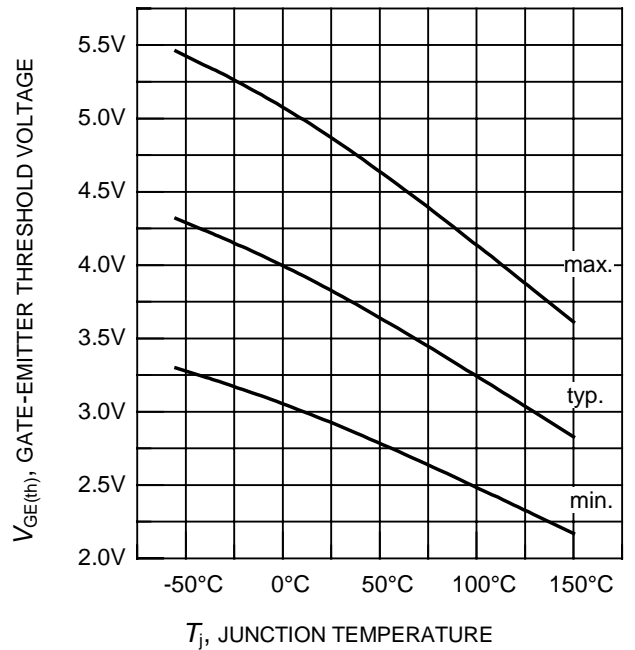

Figure 12. Gate-emitter threshold voltage as a function of junction temperature
 ($I_C = 0.7\text{mA}$)

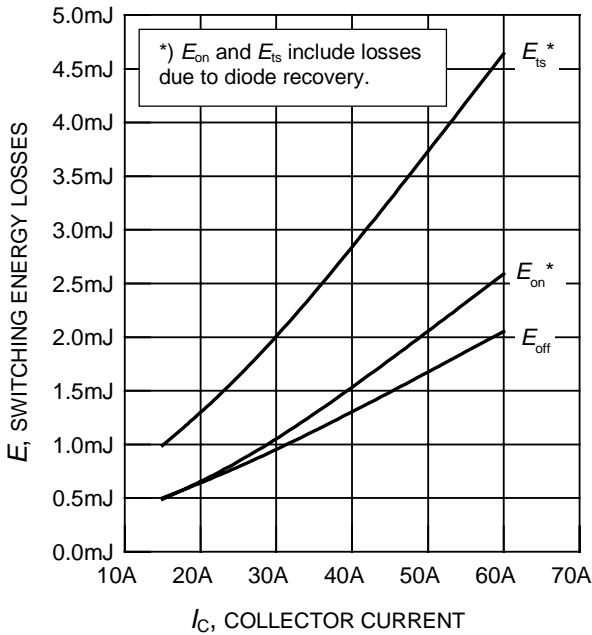

Figure 13. Typical switching energy losses as a function of collector current
 (inductive load, $T_j = 150^\circ\text{C}$, $V_{CE} = 400\text{V}$, $V_{GE} = 0/+15\text{V}$, $R_G = 11\Omega$, Dynamic test circuit in Figure E)

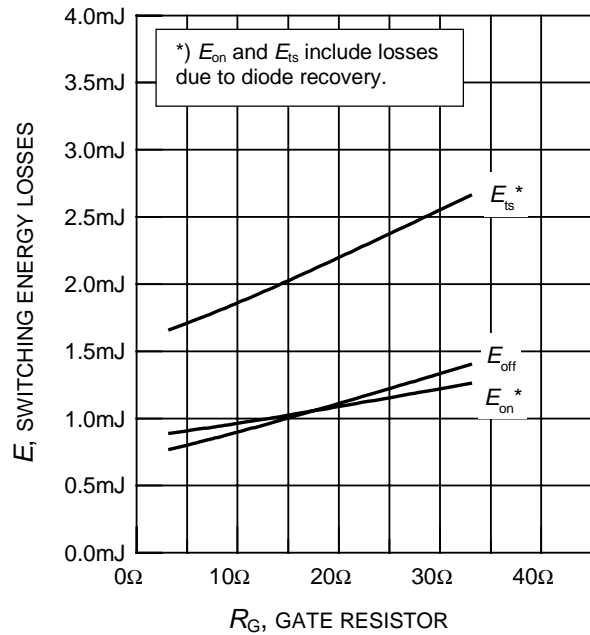

Figure 14. Typical switching energy losses as a function of gate resistor
 (inductive load, $T_j = 150^\circ\text{C}$, $V_{CE} = 400\text{V}$, $V_{GE} = 0/+15\text{V}$, $I_C = 30\text{A}$, Dynamic test circuit in Figure E)

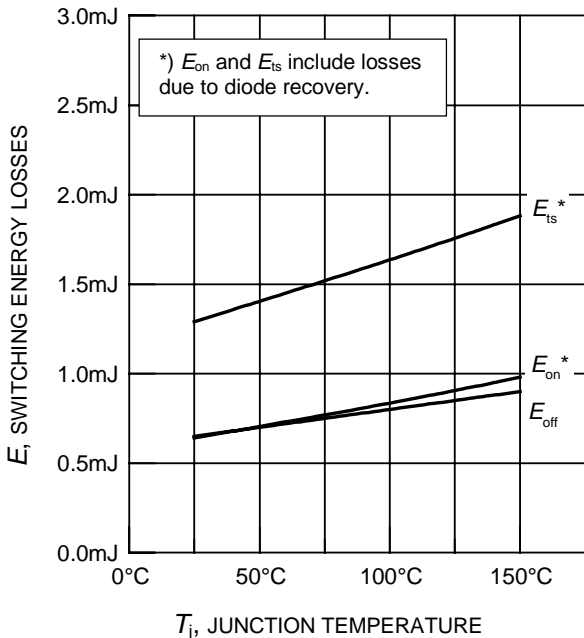

Figure 15. Typical switching energy losses as a function of junction temperature
 (inductive load, $V_{CE} = 400\text{V}$, $V_{GE} = 0/+15\text{V}$, $I_C = 30\text{A}$, $R_G = 11\Omega$, Dynamic test circuit in Figure E)

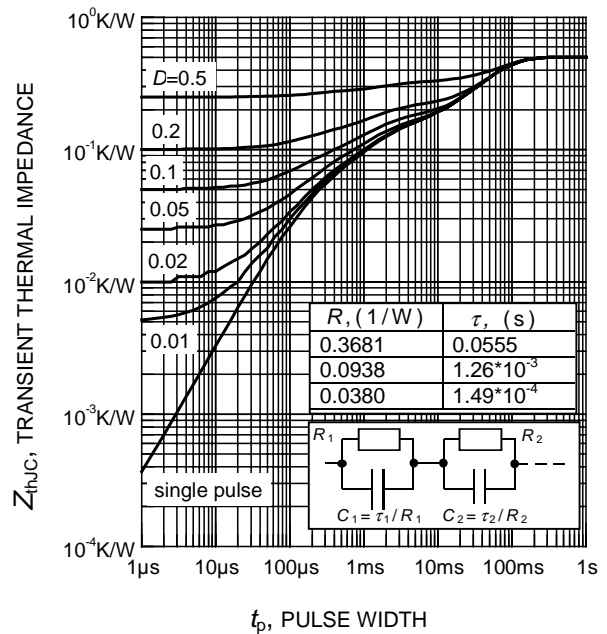

Figure 16. IGBT transient thermal impedance as a function of pulse width
 ($D = t_p / T$)

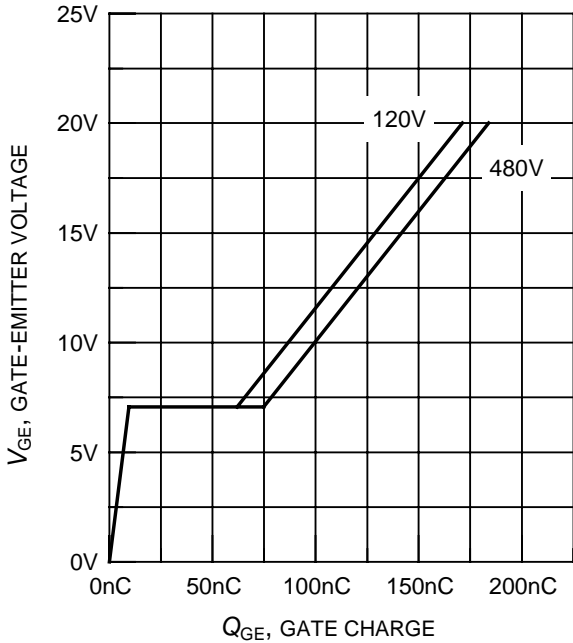

Figure 17. Typical gate charge
($I_C = 30A$)

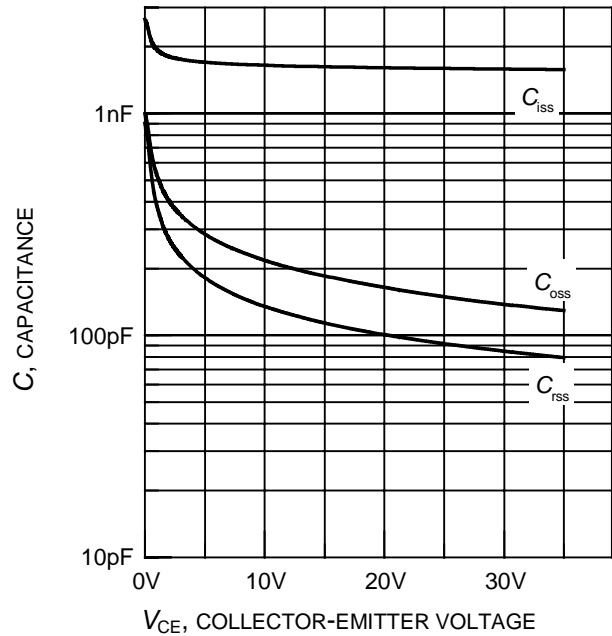

Figure 18. Typical capacitance as a function of collector-emitter voltage
($V_{GE} = 0V, f = 1MHz$)

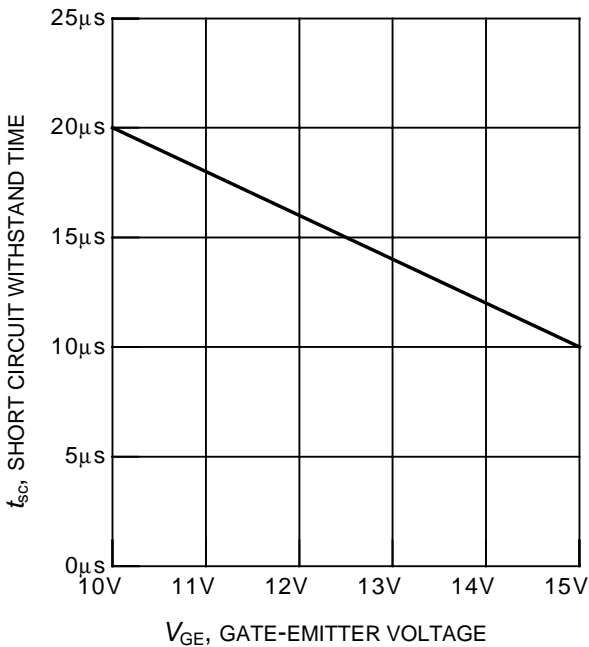

Figure 19. Short circuit withstand time as a function of gate-emitter voltage
($V_{CE} = 600V, \text{start at } T_j = 25^\circ C$)

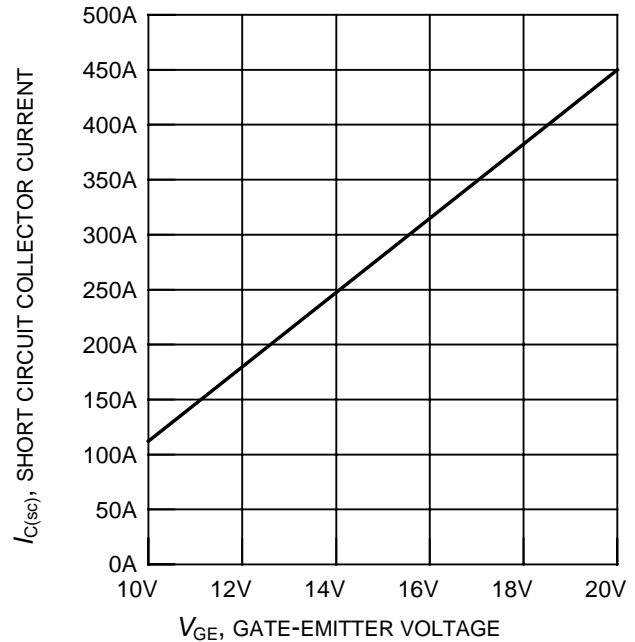

Figure 20. Typical short circuit collector current as a function of gate-emitter voltage
($V_{CE} \leq 600V, T_j = 150^\circ C$)

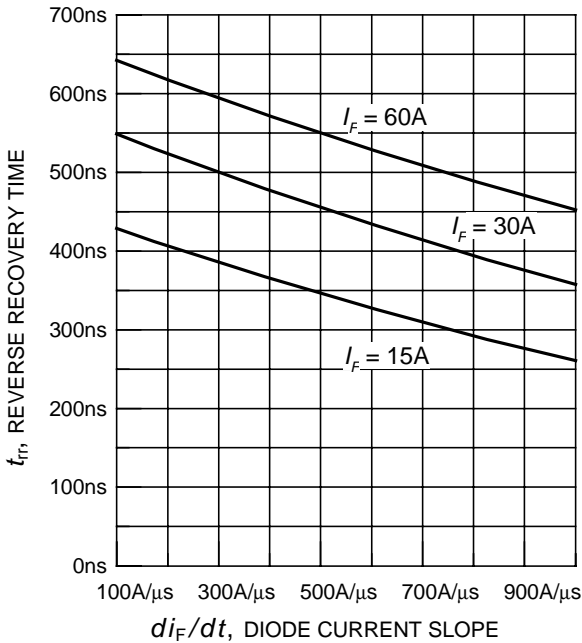

Figure 21. Typical reverse recovery time as a function of diode current slope
 ($V_R = 200V$, $T_j = 125^\circ C$,
 Dynamic test circuit in Figure E)

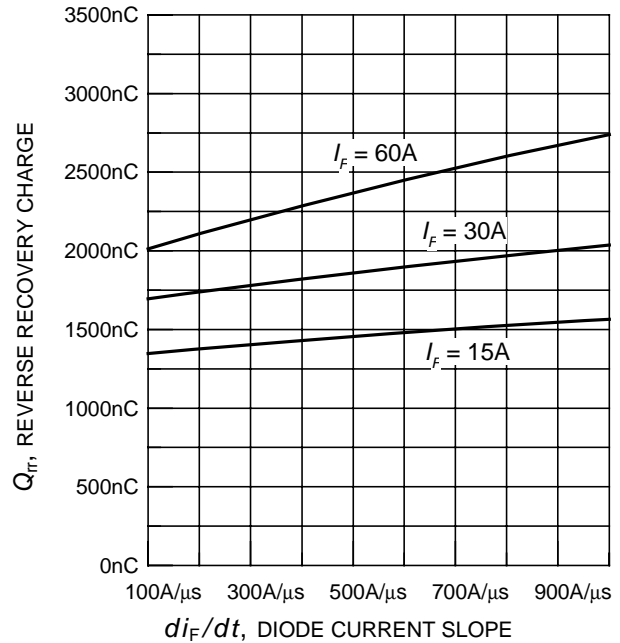

Figure 22. Typical reverse recovery charge as a function of diode current slope
 ($V_R = 200V$, $T_j = 125^\circ C$,
 Dynamic test circuit in Figure E)

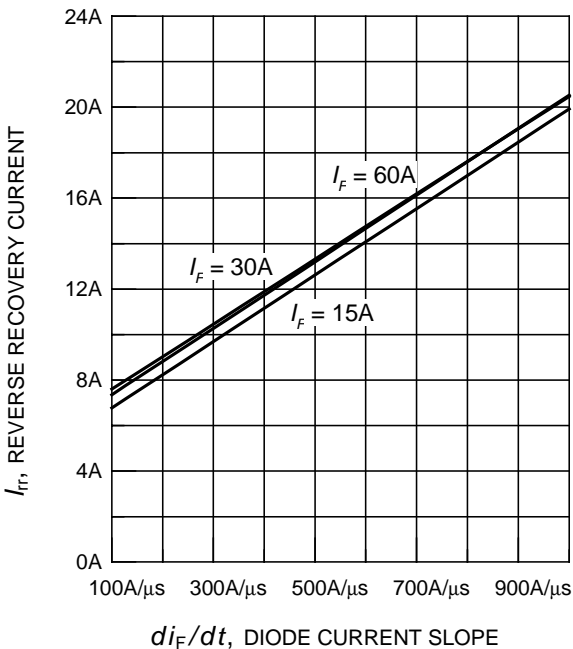

Figure 23. Typical reverse recovery current as a function of diode current slope
 ($V_R = 200V$, $T_j = 125^\circ C$,
 Dynamic test circuit in Figure E)

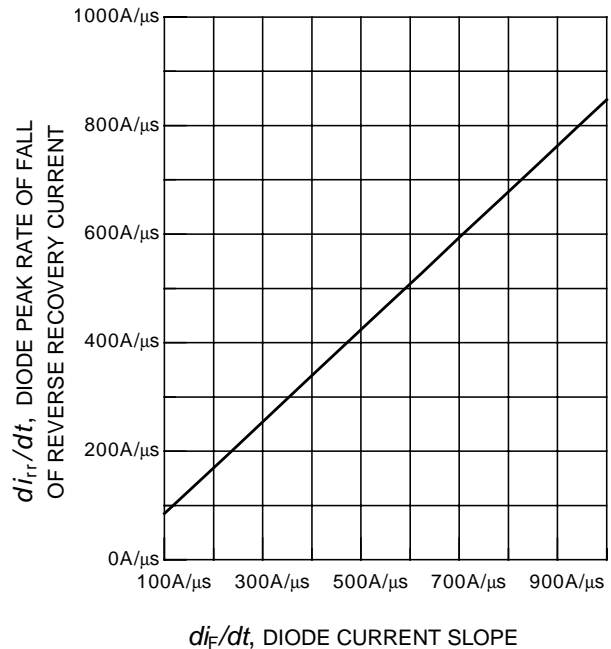

Figure 24. Typical diode peak rate of fall of reverse recovery current as a function of diode current slope
 ($V_R = 200V$, $T_j = 125^\circ C$,
 Dynamic test circuit in Figure E)

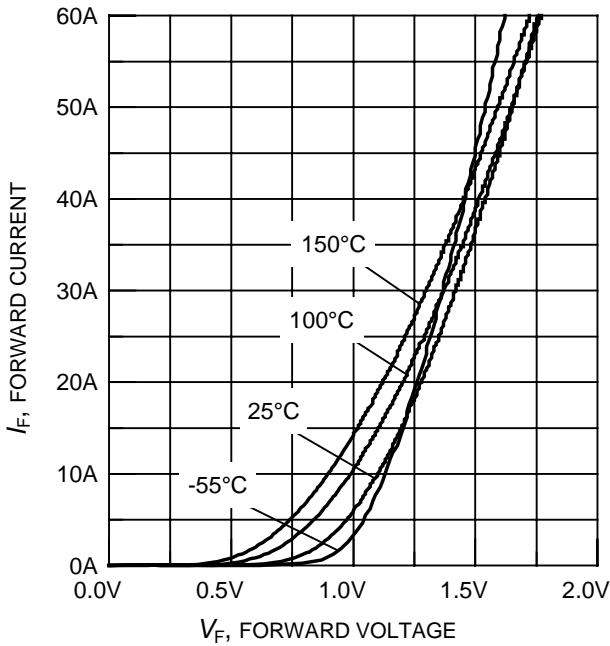

Figure 25. Typical diode forward current as a function of forward voltage

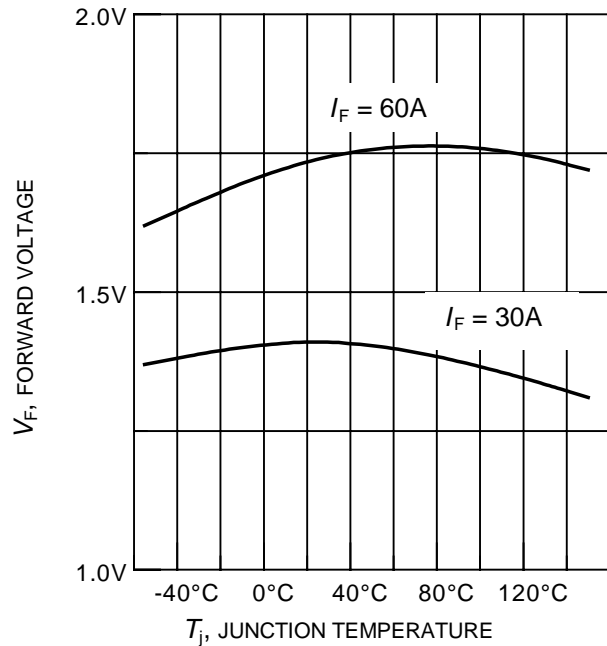

Figure 26. Typical diode forward voltage as a function of junction temperature

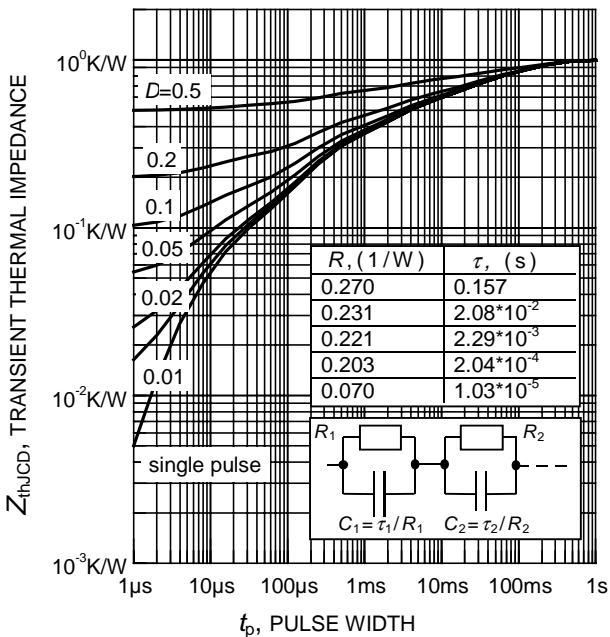
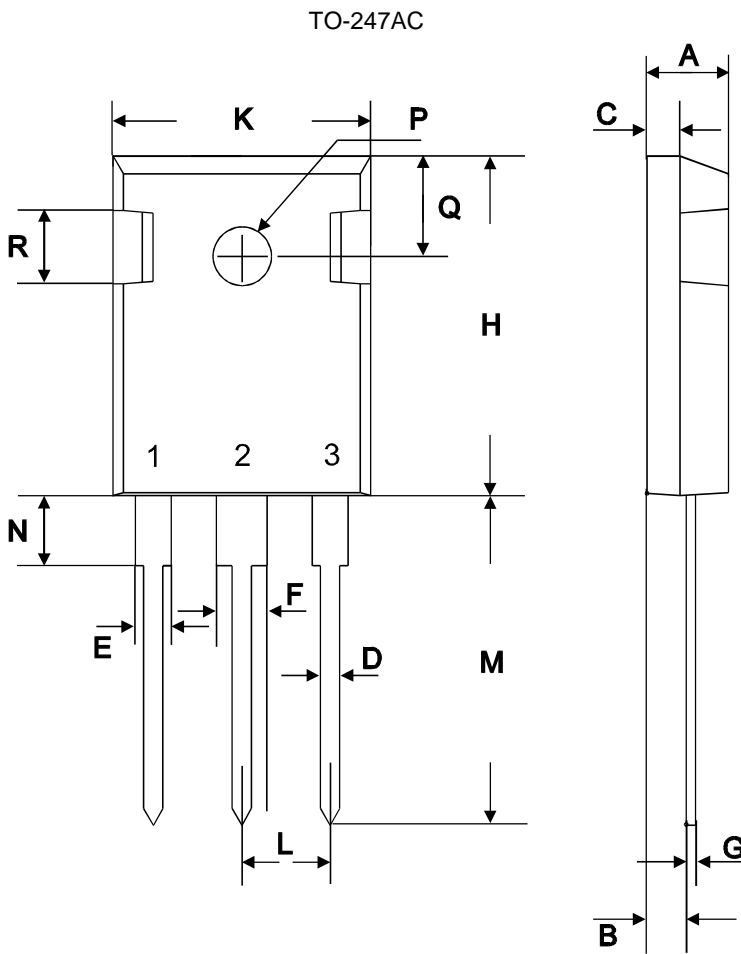

Figure 27. Diode transient thermal impedance as a function of pulse width ($D = t_p / T$)



| symbol | dimensions | | | |
|--------|------------|-------|------------|--------|
| | [mm] | | [inch] | |
| | min | max | min | max |
| A | 4.78 | 5.28 | 0.1882 | 0.2079 |
| B | 2.29 | 2.51 | 0.0902 | 0.0988 |
| C | 1.78 | 2.29 | 0.0701 | 0.0902 |
| D | 1.09 | 1.32 | 0.0429 | 0.0520 |
| E | 1.73 | 2.06 | 0.0681 | 0.0811 |
| F | 2.67 | 3.18 | 0.1051 | 0.1252 |
| G | 0.76 max | | 0.0299 max | |
| H | 20.80 | 21.16 | 0.8189 | 0.8331 |
| K | 15.65 | 16.15 | 0.6161 | 0.6358 |
| L | 5.21 | 5.72 | 0.2051 | 0.2252 |
| M | 19.81 | 20.68 | 0.7799 | 0.8142 |
| N | 3.560 | 4.930 | 0.1402 | 0.1941 |
| ∅P | 3.61 | | 0.1421 | |
| Q | 6.12 | 6.22 | 0.2409 | 0.2449 |

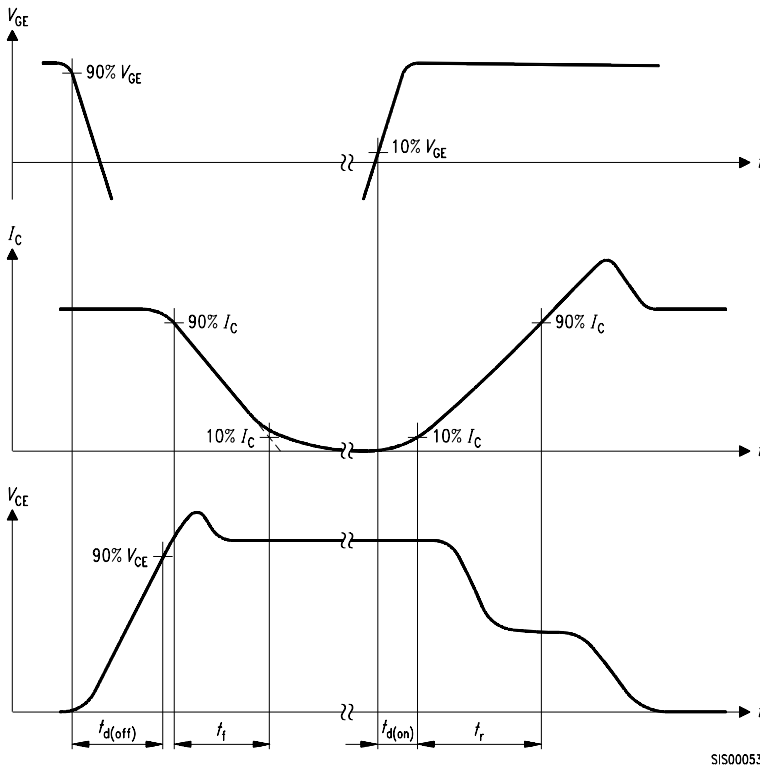

Figure A. Definition of switching times

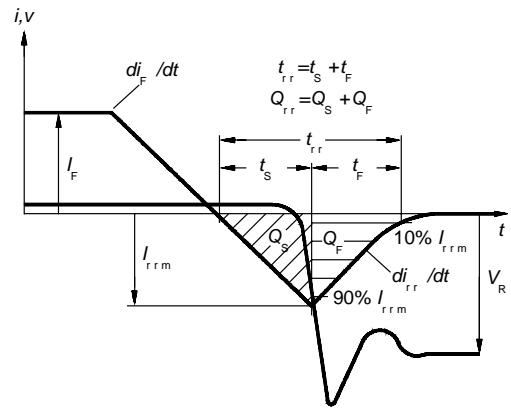

Figure C. Definition of diodes switching characteristics

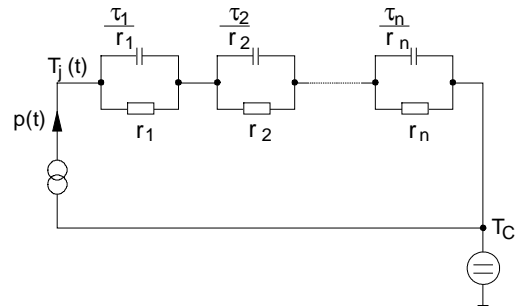

Figure D. Thermal equivalent circuit

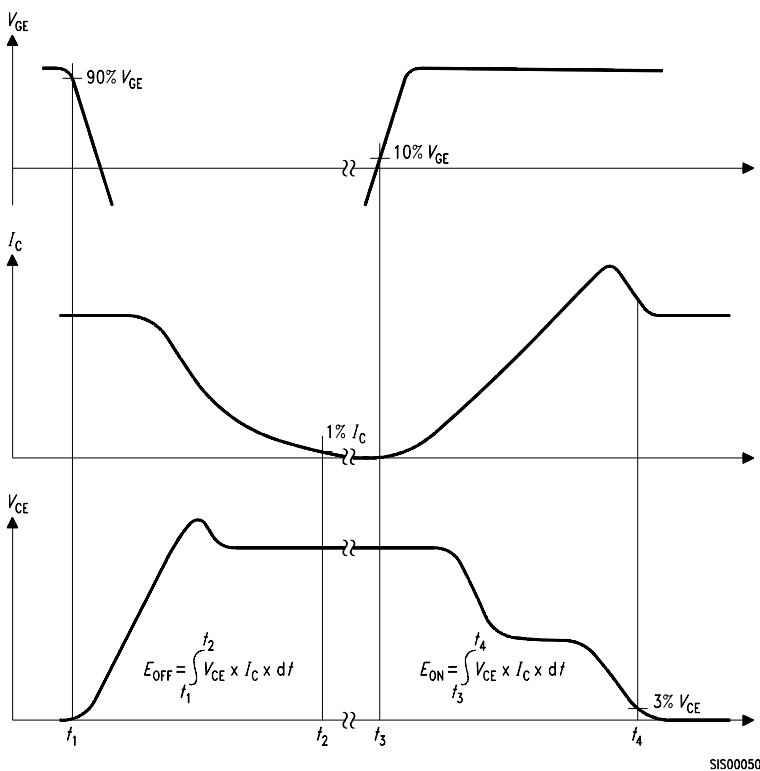

Figure B. Definition of switching losses

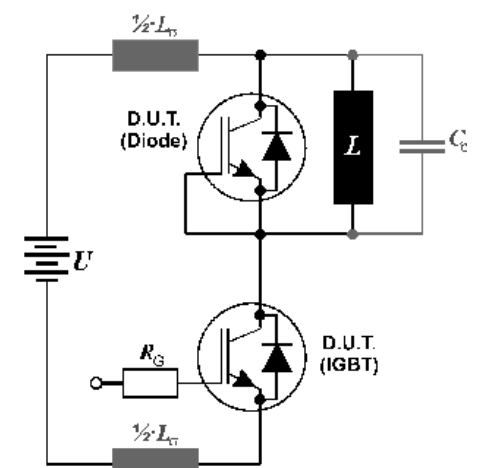

Figure E. Dynamic test circuit
Leakage inductance $L_{\sigma} = 180\text{nH}$
and Stray capacity $C_{\sigma} = 900\text{pF}$.

Bereich Kommunikation
St.-Martin-Strasse 53,
D-81541 München
© Infineon Technologies AG 2000
All Rights Reserved.

Attention please!

The information herein is given to describe certain components and shall not be considered as warranted characteristics.

Terms of delivery and rights to technical change reserved.

We hereby disclaim any and all warranties, including but not limited to warranties of non-infringement, regarding circuits, descriptions and charts stated herein.

Infineon Technologies is an approved CECC manufacturer.

Information

For further information on technology, delivery terms and conditions and prices please contact your nearest Infineon Technologies Office in Germany or our Infineon Technologies Representatives worldwide (see address list).

Warnings

Due to technical requirements components may contain dangerous substances. For information on the types in question please contact your nearest Infineon Technologies Office.

Infineon Technologies Components may only be used in life-support devices or systems with the express written approval of Infineon Technologies, if a failure of such components can reasonably be expected to cause the failure of that life-support device or system, or to affect the safety or effectiveness of that device or system. Life support devices or systems are intended to be implanted in the human body, or to support and/or maintain and sustain and/or protect human life. If they fail, it is reasonable to assume that the health of the user or other persons may be endangered.

This datasheet has been download from:

www.datasheetcatalog.com

Datasheets for electronics components.