

## FEATURES

- High accuracy output voltage
- Guaranteed 100 mA output
- Very low quiescent current
- Extremely tight load and line regulation
- Very low temperature coefficient
- Current and thermal limiting
- Low dropout voltage
- Need only 1uF for stability
- Error flag warns of output dropout
- Logi-control electronic shutdown
- Output programmable from 1.24 to 29V

## Applications

- High-efficiency linear regulator, voltage reference
- Battery powered systems
- Portable consumer equipment
- Portable / Parm, Desktop / Notebook computers
- Portable Instrumentation, cordless telephones
- Automotive Electronics, Radio control systems
- SMPS Post-Regulator, Avionics

## PRODUCT DESCRIPTION

The LM2950/1 is a low power voltage regulator. This device excellent choice for use in battery powered application such as cordless telephone, radio control systems, and portable computers.

The LM2950/1 features very low quiescent current (75µA Typ.) and very low drop output voltage (Typ. 400mV at light load and 380mV at 100mA).

This includes a tight initial tolerance of 0.5% Typ., extremely good load and line regulation of 0.05% Typ., and very low output temperature coefficient, making the LM2950/1 useful as a low-power voltage reference. The error flag output feature is used as power-on reset for warn of a low output voltage, due to following batteries on input. Other feature is the logic-compatible shutdown input which enable the regulator to be switched on and off. The LM2950/1 is available in 8-pin plastic packages.

The regulator output voltage may be pin-strapped for a -XX volt or programmed from 1.24 volt to 29 volts with external pair of resistors. The LM2950/1 is offered in 3-pin to-92 package compatible with other fixed regulator.

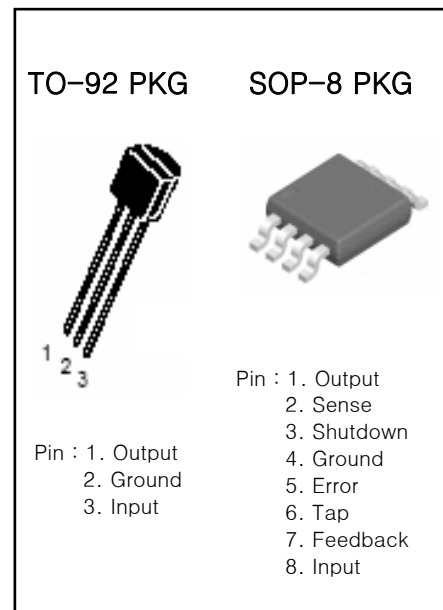

## ORDERING INFORMATION

DEVICE	PKG
LM2950L-XX	TO-92
LM2951D-XX	SOP-8

(XX= Output Voltage=3.3, 5.0V, Adjustable)

## BLOCK DIAGRAM AND TYPICAL APPLICATIONS (LM2950)

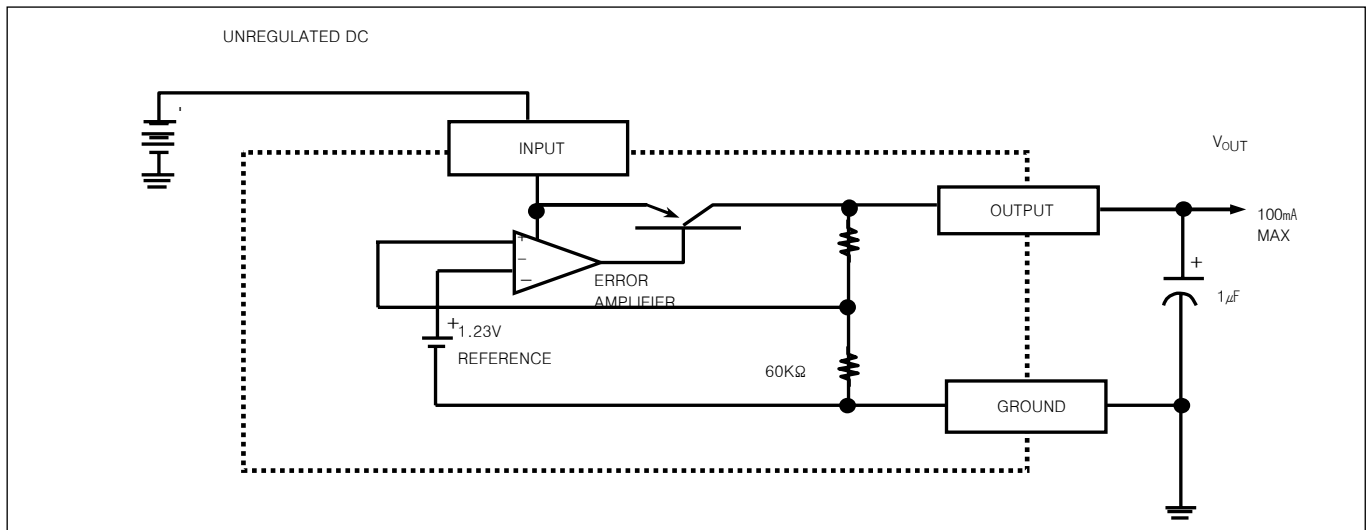

## BLOCK DIAGRAM AND TYPICAL APPLICATIONS (LM2951)

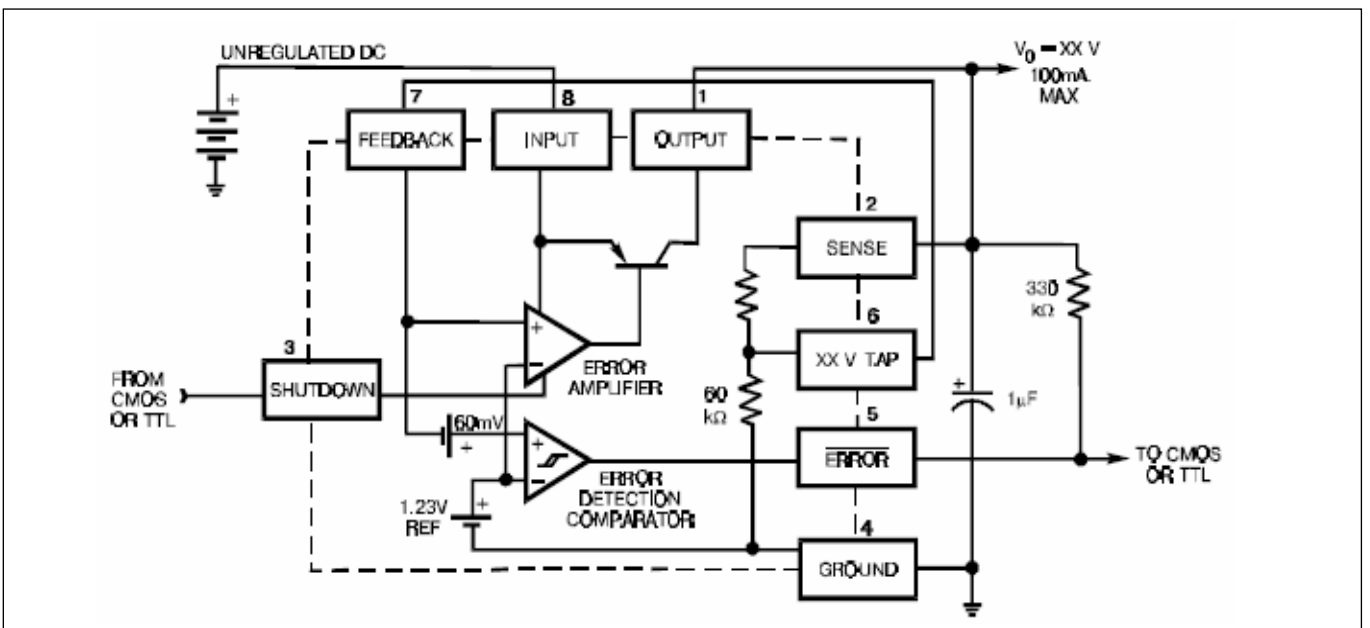

## ABSOLUTE MAXIMUM RATINGS

POWER DISSIPATION	INTERNALLY LIMITED
Lead Temperature (Soldering, 5 seconds)	260°C
Storage Temperature Range	-65°C to +150°C
Operating Junction Temperature Range	-55°C to +150°C
Input Supply Voltage	-0.3 to +30V
Feedback Input Voltage	-1.5 to +30V
Shutdown Input Voltage	-0.3 to +30V
Error Comparator Output	-0.3 to +30V

## ELECTRICAL CHARACTERISTICS(at $T_a=25^\circ\text{C}$ , $V_{IN}=15\text{V}$ , unless otherwise specified)

PARAMETER	CONDITIONS (Note 2)	MIN	TYP	MAX	UNITS
Output Voltage	$-25^\circ\text{C} \leq T_J \leq 85^\circ\text{C}$	0.985   $V_0$	$V_0$	1.015   $V_0$	V
	Full Operating Temperature	0.980   $V_0$		1.020   $V_0$	
Output Voltage	$100\mu\text{A} \leq I_L \leq 100\text{mA}$ , $T_J \leq T_{JMAX}$	0.976   $V_0$	$V_0$	1.024   $V_0$	
Output Voltage Temperature Coefficient	(Note 1)		50	150	ppm/ $^\circ\text{C}$
Line Regulation (Note 3)	$V_0+1\text{V} \leq V_{IN} \leq 30\text{V}$		0.04	0.4	%
Load Regulation (Note 3)	$100\mu\text{A} \leq I_L \leq 100\text{mA}$		0.1	0.3	%
Dropout Voltage (Note 4)	$I_L=100\mu\text{A}$		50	80	mV
	$I_L=100\text{mA}$		380	450	

## ELECTRICAL CHARACTERISTICS(at $T_a=25^\circ\text{C}$ , $V_{IN}=15\text{V}$ , unless otherwise specified)

PARAMETER	CONDITIONS (Note 2)	MIN	TYP	MAX	UNITS
Ground Current	$I_L=100\mu\text{A}$		75	120	$\mu\text{A}$
	$I_L=100\text{mA}$		8	12	mA
Dropout Ground Current	$V_{IN}=V_0-0.5\text{V}$ , $I_L=100\mu\text{A}$		110	170	$\mu\text{A}$
Current Limit	$V_{OUT}=0$		160	200	mA
Thermal Regulation			0.05	0.2	%/W
Output Noise, 10Hz to 100kHz	$C_L=1\mu\text{F}$		430		$\mu\text{V}_{rms}$
	$C_L=200\mu\text{F}$		160		
	$C_L=3.3\mu\text{F}$		100		
	(Bypass=0.01 $\mu\text{F}$ pins 7 to 1)				
<b>Error Comparator</b>					
Output Leakage Current	$V_{OH}=30\text{V}$		0.01	1.0	$\mu\text{A}$
Output Low Voltage	$V_{IN}=4.5\text{V}$ , $I_{OL}=400\mu\text{A}$		150	250	mV
Upper Threshold Voltage	(Note 6)	40	60		
Lower Threshold Voltage	(Note 6)		75	15	
Hysteresis	(Note 6)		15		
<b>Shutdown Input</b>					
Input Logic Voltage	Low (Regulator ON)		1.3	0.7	V
	High (Regulator OFF)	2			
Shutdown Pin Input Current	$V_S=2.4\text{V}$		30	50	$\mu\text{A}$
	$V_S=30\text{V}$		450	600	
Regulator Output Current Shutdown	(Note 7)				
	$V_{OUT}=5.0\text{V}$		3	10	
	$3.3\text{V} \leq V_{OUT} < 5.0\text{V}$			20	
	$2.0\text{V} \leq V_{OUT} < 3.3\text{V}$			30	

Note 1 : Output or reference voltage temperature coefficients defined as the worst case voltage change divided by the total temperature range.

Note 2 : Unless otherwise specified all limits guaranteed for  $T_J=25^\circ\text{C}$ ,  $V_{IN}=V_0+1\text{V}$ ,  $I_L=100\mu\text{A}$  and  $C_L=1\mu\text{F}$ . Additional condition for the 8-pin versions are feedback tied to -XX V tap and output tied to output Sense ( $V_{OUT}=XX\text{ V}$ ) and  $V_{SHUTDOWN}\leq 0.8\text{V}$

Note 3 : Regulation is measured at constant junction temperature, using pulse testing with a low duty cycle. Changes in output voltage due to heating effects are covered under the specification for thermal regulation.

Note 4 : Dropout voltage is defined as the input to output differential at which the output voltage drops 100mV below its nominal value measured at 1V differential. At very low values of programmed output voltage, the minimum input supply voltage (2.3V over temperature) must be taken into account.

Note 5 :  $V_{REF}\leq V_{OUT}\leq (V_{IN}-1\text{V})$ ,  $2.3\text{V}\leq V_{IN}\leq 30\text{V}$ ,  $100\mu\text{A}\leq I_L\leq 100\text{mA}$ ,  $T_J\leq T_{JMAX}$

Note 6 : Comparator thresholds are expressed in terms of a voltage differential at the feedback terminal below the nominal reference voltage measured at  $V_0+1\text{V}$  input. To express these thresholds in terms of output voltage changed, multiply by the error amplifier gain  $=V_{OUT}/V_{REF}=(R1+R2)/R2$ . For example, at a programmed output voltage of 5V, the error output is guaranteed to go low when the output drops by  $95\text{mV}\times 5\text{V}/1.235\text{V}=384\text{mV}$ . Thresholds remain constant as a percent  $V_{OUT}$  as  $V_{OUT}$  is varied, with the dropout warning occurring at typically 5% below nominal, 7.5% guaranteed.

Note 7 :  $V_{SHUTDOWN}\geq 2\text{V}$ ,  $V_{IN}\leq 30\text{V}$ ,  $V_{OUT}=0$ , Feed-back pin tied to -XX V Tap.