

FEATURES

- Qualified to AEC-Q100 Standard
- Output Current Up to 1A
- Low Dropout Voltage (1.2V at 1A Output current)
- Three Terminal Adjustable(ADJ) or Fixed 1.2V, 1.5V, 1.8V, 2.5V, 2.85V, 3.3V, 5.0V
- Line Regulation typically at 0.1% max.
- Load Regulation typically at 0.2% max.
- Internal Current and Terminal Protection
- Maximum Input Voltage 15V
- Surface Mount Package SOT-223
- 100% Thermal Limit Burn-In
- Moisture Sensitivity Level 3

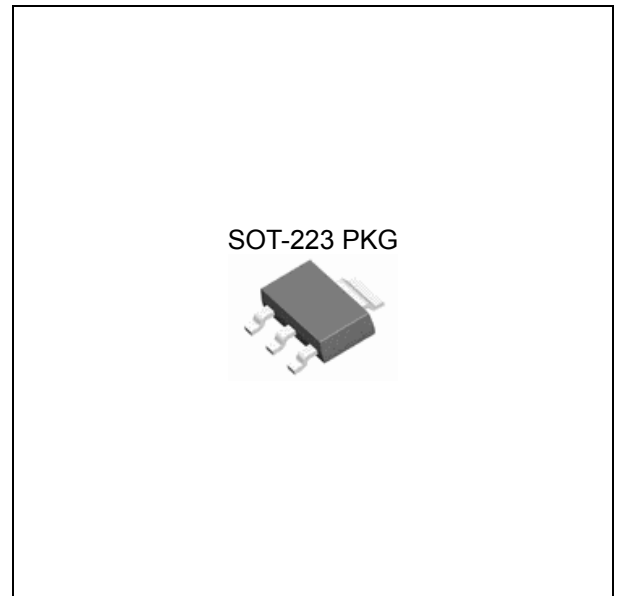

APPLICATION

- Automotive

ORDERING INFORMATION

Device	Package
LM1117QS-ADJ	SOT-223 3L
LM1117QS-X.X	

X.X = Output Voltage = 1.2V, 1.5V, 1.8V, 2.5V, 2.85V, 3.3V, 5.0V

DESCRIPTION

The LM1117Q is a low power positive-voltage regulator designed to meet 1A output current and comply with SCSI-II specifications with a fixed output voltage of 2.85V. This device is an excellent choice for use in battery-powered applications, as active terminators for the SCSI bus, and portable computers. The LM1117Q features very low quiescent current and very low dropout voltage of 1V at a full load and lower as output current decreases. LM1117Q is available as an adjustable or fixed 1.2V, 1.5V, 1.8V, 2.5V, 2.85, 3.3V, and 5.0V output voltages. The LM1117Q is offered in a 3-pin surface mount package SOT-223. The output capacitor of 10 μ F or larger is needed for output stability of LM1117Q as required by most of the other regulator circuits.

Absolute Maximum Ratings

(T_A = 25°C, unless otherwise specified)

CHARACTERISTIC	SYMBOL	MIN.	MAX.	UNIT
DC Input Voltage	V _{IN}	-	15	V
Lead Temperature (Soldering, 5 seconds)	T _{SOL}	-	260	°C
Operating Junction Temperature Range	T _{OPR}	-40	125	°C
Storage Temperature Range	T _{STG}	-65	150	°C

Ordering Information

V _{OUT}	Package	Order No.	Package Marking	Supplied As	Status
ADJ	SOT-223	LM1117QS-ADJ	1117Q ADJ	Reel	Active
1.2V	SOT-223	LM1117QS-1.2	1117Q 1.2	Reel	Active
1.5V	SOT-223	LM1117QS-1.5	1117Q 1.5	Reel	Active
1.8V	SOT-223	LM1117QS-1.8	1117Q 1.8	Reel	Active
2.5V	SOT-223	LM1117QS-2.5	1117Q 2.5	Reel	Active
2.85V	SOT-223	LM1117QS-2.85	1117Q 2.85	Reel	Active
3.3V	SOT-223	LM1117QS-3.3	1117Q 3.3	Reel	Active
5.0V	SOT-223	LM1117QS-5.0	1117Q 5.0	Reel	Active

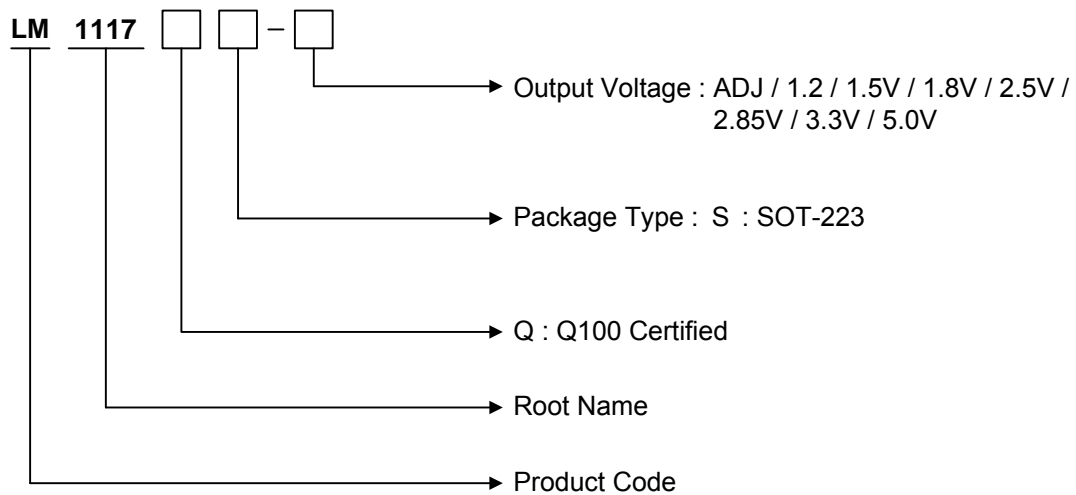

PIN CONFIGURATION

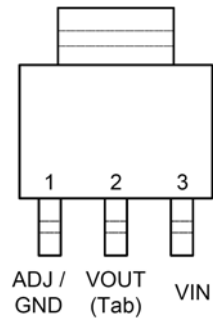

SOT-223

PIN DESCRIPTION

Pin No.	SOT-223	
	Name	Function
1	ADJ/GND	Adjustable / Ground
2	V _{OUT}	Output Voltage
3	V _{IN}	Input Voltage

ELECTRICAL CHARACTERISTICS
For ADJ Output Voltage

 (T_A=25°C, C_O = 10uF unless otherwise specified)

Symbol	Parameters	Condition	Min.	Typ.	Max.	Unit
V _{REF}	Reference Voltage	V _{IN} =5V, I _O =10mA	1.238	1.250	1.262	V
V _{REF}	Reference Voltage	I _O = 10mA to 1A, V _{IN} - V _{REF} = 1.5V to 13.75V (T _J = 0 ~ 125°C)	1.219		1.281	V
ΔV _{LINE}	Line Regulation	I _O = 10mA, V _{IN} - V _{REF} = 1.5V to 12V		0.1	0.2	%
ΔV _{LOAD}	Load Regulation	I _O = 10mA to 1A, V _{IN} - V _{REF} = 2 V		0.2	0.4	%
V _{IN}	Operating Input Voltage				15	V
I _{ADJ}	Adjustment pin Current	V _{IN} - V _{REF} = 1.5V to 12V, I _O = 100mA		50	120	uA
ΔI _{ADJ}	Adjustment Pin Current Change	V _{IN} - V _{REF} = 1.5V to 12V, I _O = 100mA to 1A		0.5	5	uA
I _{O(MIN)}	Minimum Load Current	V _{IN} =5V, V _{REF} =0V		5	10	mA
I _O	Current Limit	V _{IN} - V _{REF} = 5V	1000	1250		mA
ε _N	Output Noise(%V _O)	B = 10Hz to 10kHz, T _J = 25°C		0.003		%
SVR	Supply Voltage Rejection	I _O = 1A, f = 120Hz, V _{IN} - V _{REF} = 3V, V _{RIPPLE} = 1V _{PP}	60	75		dB

For 1.2V Output Voltage

 (T_A=25°C, C_O = 10uF unless otherwise specified)

Symbol	Parameters	Condition	Min.	Typ.	Max.	Unit
V _O	Output Voltage	V _{IN} = 2.7V, I _O = 10mA	1.176	1.200	1.224	V
V _O	Output Voltage	V _{IN} = 2.7V to 12V, I _O = 0mA to 1A (T _J = 0 ~ 125°C)	1.152		1.248	V
ΔV _{LINE}	Line Regulation	I _O = 0mA, V _{IN} = 2.7V to 12V		0.1	0.2	%
ΔV _{LOAD}	Load Regulation	I _O = 10mA to 1A, V _{IN} = 3.2V		0.2	0.4	%
V _{IN}	Operating Input Voltage				15	V
I _D	Quiescent Current	V _{IN} - V _O = 5V		5	10	mA
I _O	Current Limit	V _{IN} - V _O = 5V	1000	1250		mA
ε _N	Output Noise(%V _O)	B = 10Hz to 10kHz, T _J = 25°C		0.003		%
SVR	Supply Voltage Rejection	I _O = 1A, f = 120Hz, V _{IN} - V _O = 1.5V, V _{RIPPLE} = 1V _{PP}	60	75		dB

For 1.5V Output Voltage

 (T_A=25°C, C_O = 10uF unless otherwise specified)

Symbol	Parameters	Condition	Min.	Typ.	Max.	Unit
V _O	Output Voltage	V _{IN} = 3.0V , I _O = 10mA	1.485	1.5	1.515	V
V _O	Output Voltage	V _{IN} = 3.0V to 12V, I _O = 0mA to 1A (T _J = 0 ~ 125°C)	1.470		1.530	V
ΔV _{LINE}	Line Regulation	I _O = 0mA , V _{IN} = 3.0V to 12V		0.1	0.2	%
ΔV _{LOAD}	Load Regulation	I _O = 0mA to 1A, V _{IN} = 3.5 V		0.2	0.4	%
V _{IN}	Operating Input Voltage	I _O = 100mA			12	V
I _D	Quiescent Current	V _{IN} - V _O = 5V		5	10	mA
I _O	Current Limit	V _{IN} - V _O = 5V	1000	1250		mA
εN	Output Noise(%V _O)	B = 10Hz to 10kHz, T _J = 25°C		100		uV
SVR	Supply Voltage Rejection	I _O = 1A, f = 120Hz, V _{IN} - V _O = 3V, V _{RIPPLE} = 1V _{PP}	60	75		dB

For 1.8V Output Voltage

 (T_A=25°C, C_O = 10uF unless otherwise specified)

Symbol	Parameters	Condition	Min.	Typ.	Max.	Unit
V _O	Output Voltage	V _{IN} = 3.3V, I _O = 10mA	1.782	1.8	1.818	V
V _O	Output Voltage	V _{IN} = 3.3V to 12V, I _O = 0mA to 1A (T _J = 0 ~ 125°C)	1.764		1.836	V
ΔV _{LINE}	Line Regulation	I _O = 0mA , V _{IN} = 3.3V to 12V		0.1	0.2	%
ΔV _{LOAD}	Load Regulation	I _O = 0mA to 1A, V _{IN} = 3.8 V		0.2	0.4	%
V _{IN}	Operating Input Voltage	I _O = 100mA			12	V
I _D	Quiescent Current	V _{IN} - V _O = 5V		5	10	mA
I _O	Current Limit	V _{IN} - V _O = 5V	1000	1250		mA
εN	Output Noise(%V _O)	B = 10Hz to 10kHz, T _J = 25°C		100		uV
SVR	Supply Voltage Rejection	I _O = 1A, f = 120Hz, V _{IN} - V _O = 3V, V _{RIPPLE} = 1V _{PP}	60	75		dB

For 2.5V Output Voltage

 (T_A=25°C, C_O = 10uF unless otherwise specified)

Symbol	Parameters	Condition	Min.	Typ.	Max.	Unit
V _O	Output Voltage	V _{IN} = 4.0V, I _O = 10mA	2.475	2.5	2.525	V
V _O	Output Voltage	V _{IN} = 4.0V to 12V, I _O = 0mA to 1A (T _J = 0 ~ 125°C)	2.450		2.550	V
ΔV _{LINE}	Line Regulation	I _O = 0mA, V _{IN} = 4.0V to 12V		0.1	0.2	%
ΔV _{LOAD}	Load Regulation	I _O = 0mA to 1A, V _{IN} = 4.5 V		0.2	0.4	%
V _{IN}	Operating Input Voltage	I _O = 100mA			12	V
I _D	Quiescent Current	V _{IN} - V _O = 5V		5	10	mA
I _O	Current Limit	V _{IN} - V _O = 5V	1000	1250		mA
e _N	Output Noise(%V _O)	B = 10Hz to 10kHz, T _J = 25°C		100		uV
SVR	Supply Voltage Rejection	I _O = 1A, f = 120Hz, V _{IN} - V _O = 3V, V _{RIPPLE} = 1V _{PP}	60	75		dB

For 2.85V Output Voltage

 (T_A=25°C, C_O = 10uF unless otherwise specified)

Symbol	Parameters	Condition	Min.	Typ.	Max.	Unit
V _O	Output Voltage	V _{IN} = 4.4V, I _O = 10mA	2.821	2.85	2.878	V
V _O	Output Voltage	V _{IN} = 4.4V to 12V, I _O = 0mA to 1A (T _J = 0 ~ 125°C)	2.793		2.907	V
ΔV _{LINE}	Line Regulation	I _O = 0mA, V _{IN} = 4.4 to 12V		0.1	0.2	%
ΔV _{LOAD}	Load Regulation	I _O = 0mA to 1A, V _{IN} = 4.85 V		0.2	0.4	%
V _{IN}	Operating Input Voltage	I _O = 100mA			12	V
I _D	Quiescent Current	V _{IN} - V _O = 5V		5	10	mA
I _O	Current Limit	V _{IN} - V _O = 5V	1000	1250		mA
e _N	Output Noise(%V _O)	B = 10Hz to 10kHz, T _J = 25°C		100		uV
SVR	Supply Voltage Rejection	I _O = 1A, f = 120Hz, V _{IN} - V _O = 3V, V _{RIPPLE} = 1V _{PP}	60	75		dB

For 3.3V Output Voltage

 (T_A=25°C, C_O = 10uF unless otherwise specified)

Symbol	Parameters	Condition	Min.	Typ.	Max.	Unit
V _O	Output Voltage	V _{IN} = 4.8V, I _O = 10mA	3.267	3.3	3.333	V
V _O	Output Voltage	V _{IN} = 4.8V to 12V, I _O = 0mA to 1A (T _J = 0 ~ 125°C)	3.234		3.366	V
ΔV _{LINE}	Line Regulation	I _O = 0mA, V _{IN} = 4.8V to 12V		0.1	0.2	%
ΔV _{LOAD}	Load Regulation	I _O = 0mA to 1A, V _{IN} = 5.3 V		0.2	0.4	%
V _{IN}	Operating Input Voltage	I _O = 100mA			12	V
I _D	Quiescent Current	V _{IN} - V _O = 5V		5	10	mA
I _O	Current Limit	V _{IN} - V _O = 5V	1000	1250		mA
e _N	Output Noise(%V _O)	B = 10Hz to 10kHz, T _J = 25°C		100		uV
SVR	Supply Voltage Rejection	I _O = 1A, f = 120Hz, V _{IN} - V _O = 3V, V _{RIPPLE} = 1V _{PP}	60	75		dB

For 5.0V Output Voltage

 (T_A=25°C, C_O = 10uF unless otherwise specified)

Symbol	Parameters	Condition	Min.	Typ.	Max.	Unit
V _O	Output Voltage	V _{IN} = 6.5V, I _O = 10mA	4.950	5.0	5.050	V
V _O	Output Voltage	V _{IN} = 6.5V to 15V, I _O = 0mA to 1A (T _J = 0 ~ 125°C)	4.900		5.100	V
ΔV _{LINE}	Line Regulation	I _O = 0mA, V _{IN} = 6.5V to 15V		0.1	0.2	%
ΔV _{LOAD}	Load Regulation	I _O = 0mA to 1A, V _{IN} = 7.0 V		0.2	0.4	%
V _{IN}	Operating Input Voltage	I _O = 100mA			15	V
I _D	Quiescent Current	V _{IN} - V _O = 5V		5	10	mA
I _O	Current Limit	V _{IN} - V _O = 5V	1000	1250		mA
e _N	Output Noise(%V _O)	B = 10Hz to 10kHz, T _J = 25°C		100		uV
SVR	Supply Voltage Rejection	I _O = 1A, f = 120Hz, V _{IN} - V _O = 3V, V _{RIPPLE} = 1V _{PP}	60	75		dB

For All Output Voltage

($T_A=25^\circ\text{C}$, $C_O = 10\mu\text{F}$ unless otherwise specified)

Symbol	Parameters	Condition	Min.	Typ.	Max.	Unit
V_D	Dropout Voltage	$I_O = 100\text{mA}$		1.0	1.1	V
		$I_O = 500\text{mA}$		1.1	1.2	V
		$I_O = 1\text{A}$		1.2	1.3	V
	Temperature Stability			0.5		%
	Long Term Stability	1000 hrs, $T_J = 125^\circ\text{C}$		0.3		%
	Thermal Regulation	$T_A = 25^\circ\text{C}$ 30ms Pulse		0.003		%/W

TYPICAL APPLICATION CIRCUIT

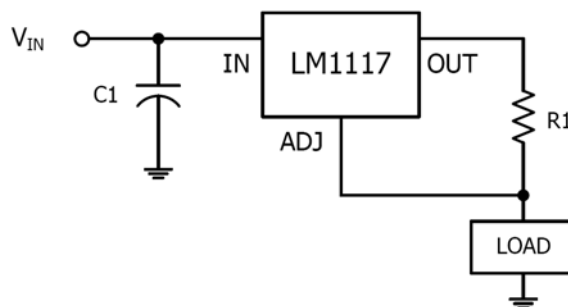

Fig.1 1A Current Output

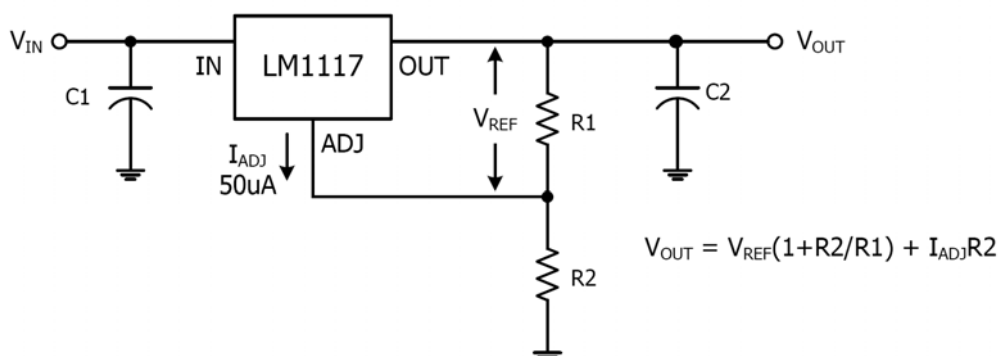

Fig.2 Typical Adjustable Regulator

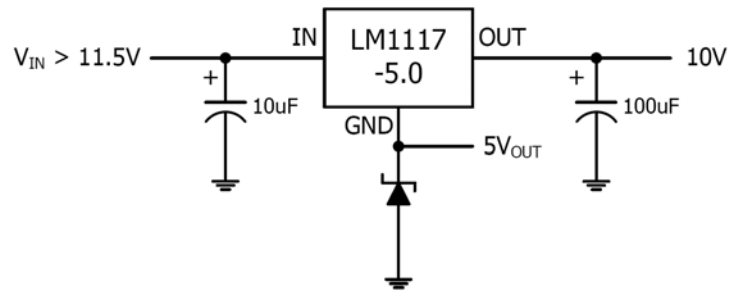

Fig.3 Voltage Regulator with Reference

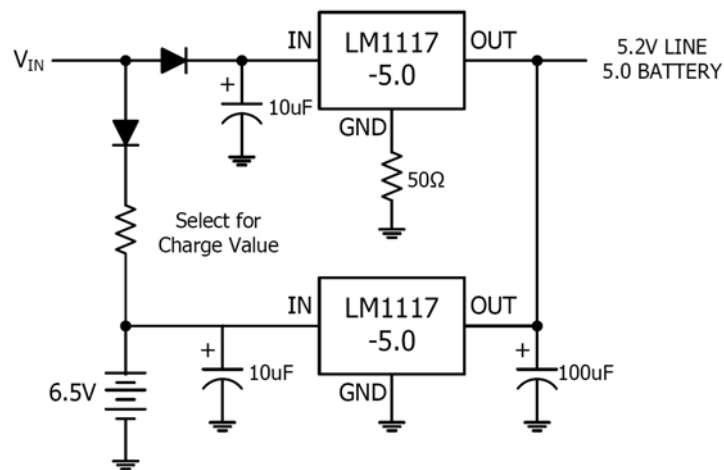

Fig.4 Battery Backed-up Regulated Supply

TYPICAL OPERATING CHARACTERISTICS

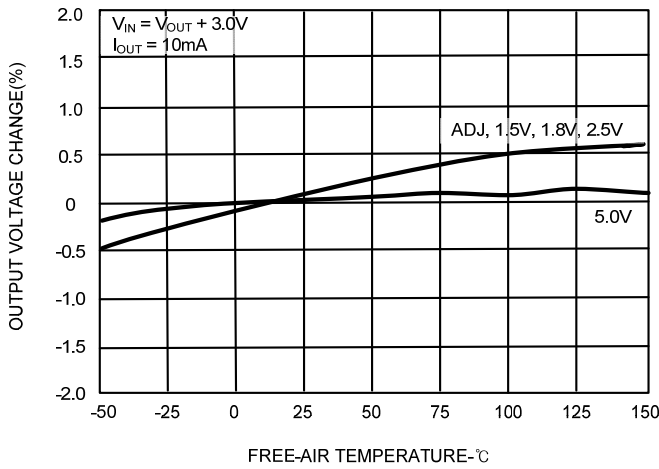

Fig.7 OUTPUT VOLTAGE CHANGE VS TEMPERATURE

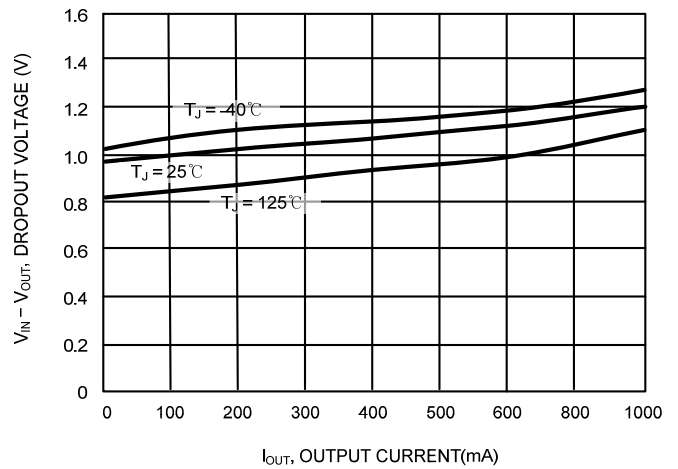

Fig.8 DROPOUT VOLTAGE VS OUTPUT CURRENT

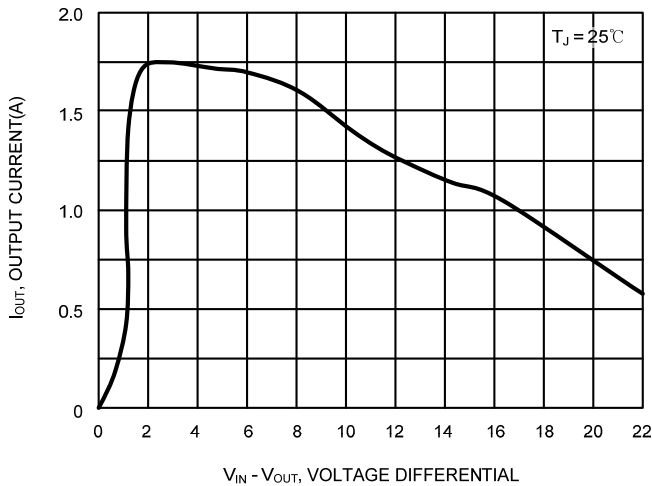

Fig.9 OUTPUT SHORT CIRCUIT CURRENT VS DIFFERENTIAL VOLTAGE

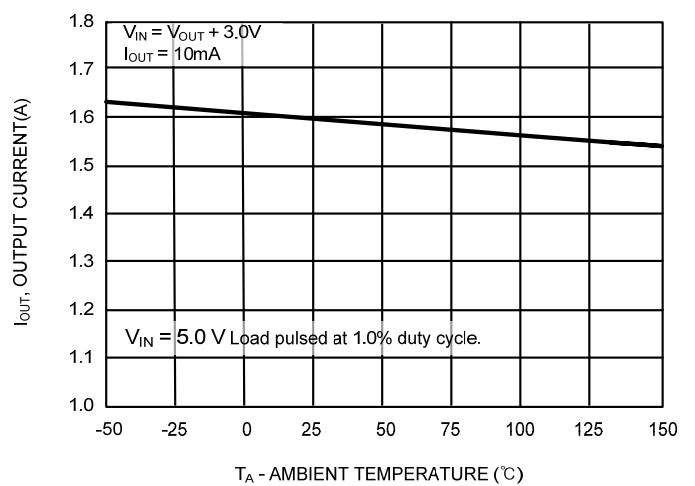

Fig.10 OUTPUT SHORT CIRCUIT CURRENT VS TEMPERATURE

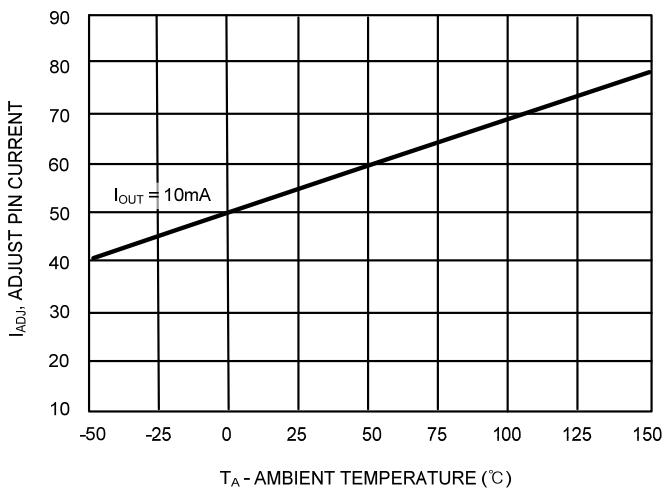

Fig.11 ADJ PIN CURRENT VS TEMPERATURE

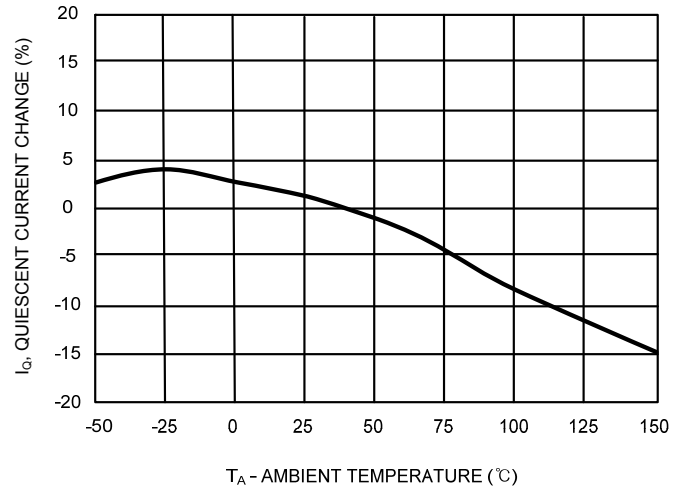

Fig.12 QUIESCIENT CURRENT CHANGE VS TEMPERATURE

APPLICATION INFORMATION

Maximum Output Current Capability

The LM1117Q can deliver a continuous current of 1A over the full operating junction temperature range. However, the output current is limited by the restriction of power dissipation which differs from packages. A heat sink may be required depending on the maximum power dissipation and maximum ambient temperature of application. With respect to the applied package, the maximum output current of 1A may be still undeliverable due to the restriction of the power dissipation of LM1117Q. Under all possible conditions, the junction temperature must be within the range specified under operating conditions. The temperatures over the device are given by:

$$T_C = T_A + P_D \times \theta_{CA} / \quad T_J = T_C + P_D \times \theta_{JC} / \quad T_J = T_A + P_D \times \theta_{JA}$$

where T_J is the junction temperature, T_C is the case temperature, T_A is the ambient temperature, P_D is the total power dissipation of the device, θ_{CA} is the thermal resistance of case-to-ambient, θ_{JC} is the thermal resistance of junction-to-case, and θ_{JA} is the thermal resistance of junction to ambient. The total power dissipation of the device is given by:

$$P_D = P_{IN} - P_{OUT} = (V_{IN} \times I_{IN}) - (V_{OUT} \times I_{OUT}) \\ = (V_{IN} \times (I_{OUT} + I_{GND})) - (V_{OUT} \times I_{OUT}) = (V_{IN} - V_{OUT}) \times I_{OUT} + V_{IN} \times I_{GND}$$

where I_{GND} is the operating ground current of the device which is specified at the Electrical Characteristics. The maximum allowable temperature rise (T_{Rmax}) depends on the maximum ambient temperature (T_{Amax}) of the application, and the maximum allowable junction temperature (T_{Jmax}):

$$T_{Rmax} = T_{Jmax} - T_{Amax}$$

The maximum allowable value for junction-to-ambient thermal resistance, θ_{JA} , can be calculated using the formula:

$$\theta_{JA} = T_{Rmax} / P_D = (T_{Jmax} - T_{Amax}) / P_D$$

LM1117Q is available in SOT223 package. The thermal resistance depends on amount of copper area or heat sink, and on air flow. If the maximum allowable value of θ_{JA} calculated above is over 137°C/W for SOT-223 package, no heat sink is needed since the package can dissipate enough heat to satisfy these requirements. If the value for allowable θ_{JA} falls near or below these limits, a heat sink or proper area of copper plane is required. In summary, the absolute maximum ratings of thermal resistances are as follow:

Absolute Maximum Ratings of Thermal Resistance

Characteristic	Symbol	Rating	Unit
Thermal Resistance Junction-To-Ambient / SOT-223	$\theta_{JA-SOT-223}$	137	°C/W

No heat sink / No air flow / No adjacent heat source / 0.066 inch² copper area. ($T_A=25^\circ\text{C}$)