

HIH-4000 Series

Humidity Sensors



The HIH-4000 Series Humidity Sensors are designed specifically for high volume OEM (Original Equipment Manufacturer) users. Direct input to a controller or other device is made possible by this sensor's linear voltage output. With a typical current draw of only 200 μ A, the HIH-4000 Series is often ideally suited for low drain, battery operated systems. Tight sensor interchangeability reduces or eliminates OEM production calibration costs. Individual sensor calibration data is available.

FEATURES

- Molded thermoset plastic housing
- Linear voltage output vs %RH
- Laser trimmed interchangeability
- Low power design
- High accuracy
- Fast response time
- Stable, low drift performance
- Chemically resistant

The HIH-4000 Series delivers instrumentation-quality RH (Relative Humidity) sensing performance in a competitively priced, solderable SIP (Single In-line Package). Available in two lead spacing configurations, the RH sensor is a laser trimmed, thermoset polymer capacitive sensing element with on-chip integrated signal conditioning. The sensing element's multilayer construction provides excellent resistance to most application hazards such as wetting, dust, dirt, oils and common environmental chemicals.

TYPICAL APPLICATIONS

- Refrigeration equipment
- HVAC equipment
- Medical equipment
- Drying
- Metrology
- Battery-powered systems
- OEM assemblies

HIH-4000 Series

TABLE 1. PERFORMANCE SPECIFICATIONS (At 5 Vdc supply and 25 °C [77 °F] unless otherwise noted.)
 (%RH performance specifications include test system measurement errors (±0.5 % typical).)

Parameter	Minimum	Typical	Maximum	Unit
Interchangeability (best fit straight line)	–	–	–	–
0 % to 60 %	-5	–	5	%RH
60 % to 100 %	-8	–	8	%RH
Interchangeability (2nd order curve)	–	±3.5	–	%RH
Accuracy ¹ (best fit straight line)	–	±3.5	–	%RH
Accuracy (2nd order curve)	–	±2.5	–	%RH
Hysteresis	–	3	–	%RH
Repeatability	–	±0.5	–	%RH
Settling time	–	–	70	ms
Response time (1/e in slow moving air)	–	15	–	s
Stability ² (@ 50 %RH)	–	±1.2 (per year)	–	%RH
Stability ³ (@ 50 %RH)	–	±0.2 (per year)	–	%RH
Voltage supply	4	–	5.8	Vdc
Current supply	–	–	500	µA
Voltage output (1 st order fit)	$V_{out} = V_{supply} (0.0062(\text{sensor RH}) + 0.16)$			
Voltage output (2nd order curve fit)	$V_{out} = 0.00003(\text{sensor RH})^2 + 0.0281(\text{sensor RH}) + 0.820$, typical @ 25 °C			
Temperature compensation	$V_{out} = (0.0305 + 0.000044T - 0.000011T^2)(\text{Sensor RH}) + (0.9237 - 0.0041T + 0.000040T^2)$, T=Temperature in °C			
Operating temperature	-40[-40]	See Figure 1.	85[185]	°C[°F]
Operating humidity	0	See Figure 2.	100	%RH
Storage temperature	-40[-40]	–	125[257]	°C[°F]
Storage humidity	See Figure 2.			%RH

Notes:

1. For HIH-4000-003 and -004 only.
2. Specification includes testing outside of recommended operating zone.
3. Specification includes testing for recommended operating zone only.

NOTICE

- Do not expose sensor to condensing environments. Exposure to condensing environments will cause sensor output to indicate 0 %RH.
 - Sensor is light sensitive. For best performance, shield sensor from bright light.
 - Sensor is static sensitive. Sensor connection protected to 15 kV maximum.
 - Sensor output is ratiometric to supply voltage.
- Failure to comply with these instructions could result in death or serious injury.**

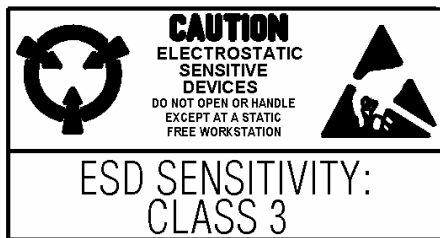

FACTORY CALIBRATION DATA

HIH-4000 Sensors may be ordered with a calibration and data printout (Table 2). See order guide on back page.

TABLE 2. EXAMPLE DATA PRINTOUT

Model	HIH-4000-001
Channel	92
Wafer	030996M
MRP	337313
Calculated values at 5 V	
V _{out} @ 0 %RH	0.958 V
V _{out} @ 75.3 %RH	3.268 V
Linear output for 2 %RH accuracy @ 25 °C	
Zero offset	0.958 V
Slope	30.680 mV/%RH
RH	(V _{out} -zero offset)/slope (V _{out} -0.958)/0.0307
Ratiometric response for 0 % to 100 %RH	
V _{out}	V _{supply} (0.1915 to 0.8130)

Humidity Sensors

FIGURE 1. RECOMMENDED OPERATING CONDITIONS

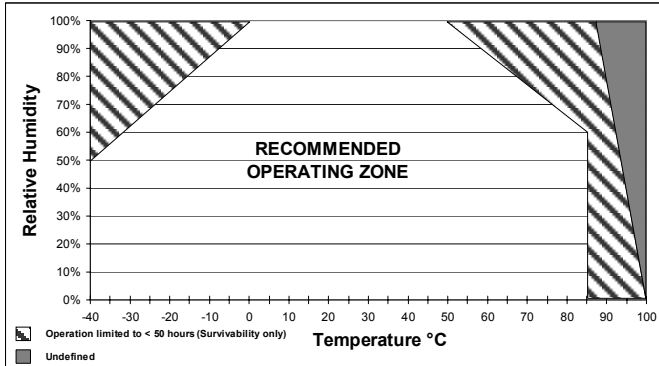

FIGURE 2. STORAGE ENVIRONMENT

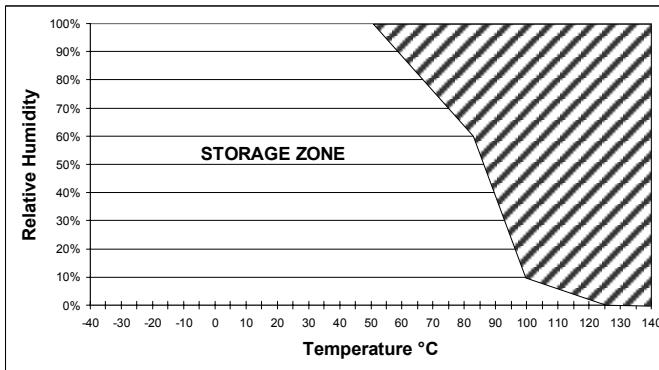

FIGURE 3. MOUNTING DIMENSIONS
for reference only mm/[in]

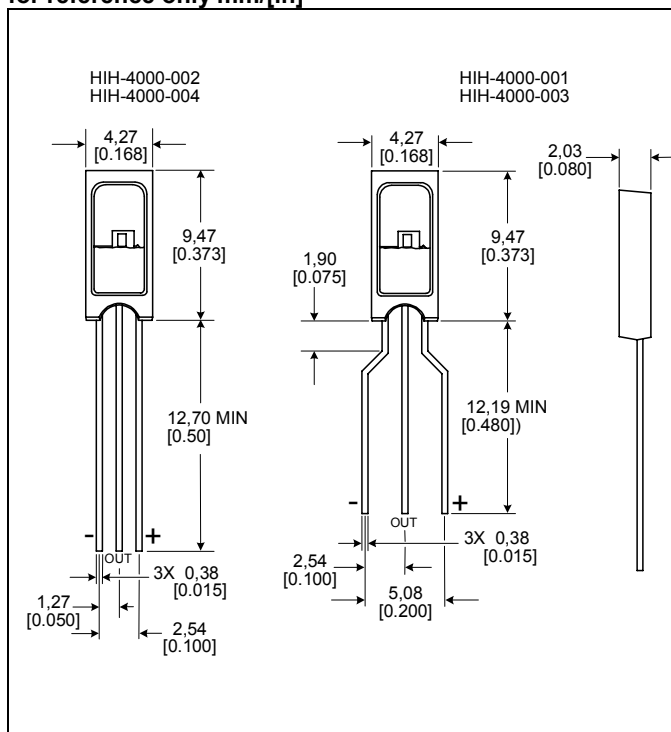

FIGURE 4. TYPICAL BEST FIT STRAIGHT LINE

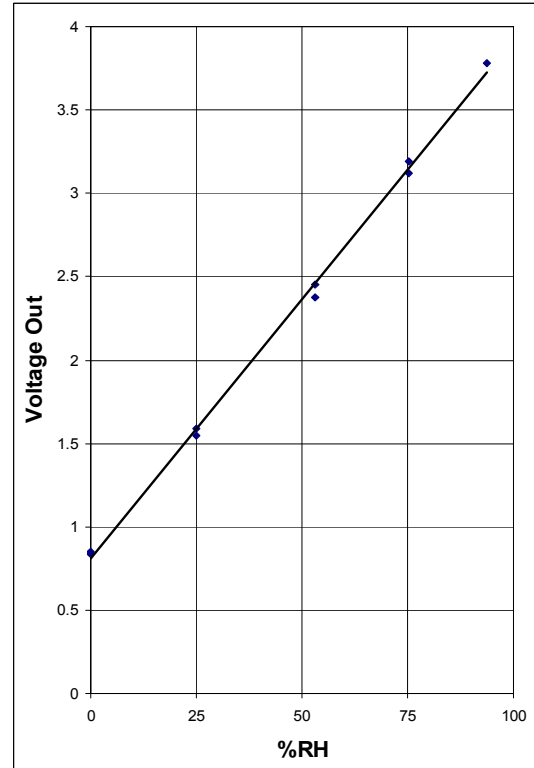
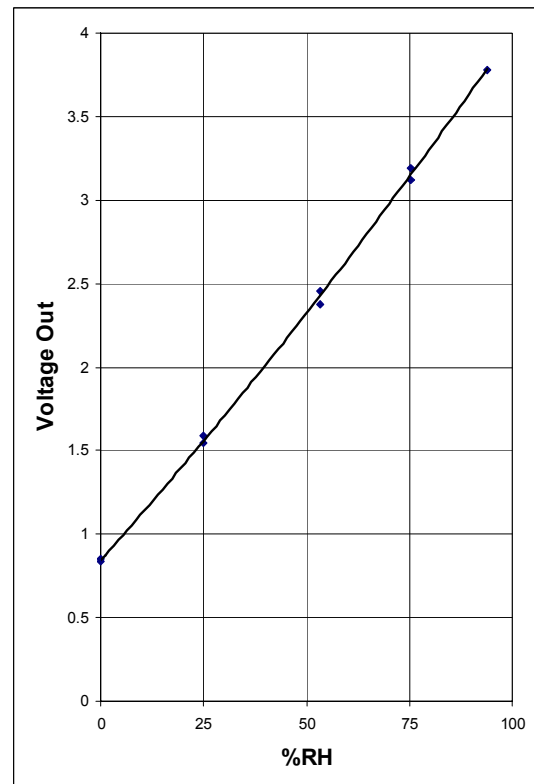

FIGURE 5. TYPICAL 2nd ORDER CURVE FIT



ORDER GUIDE

Catalog Listing	Description
HIH-4000-001	Integrated circuitry humidity sensor, 0.100 in lead pitch SIP
HIH-4000-002	Integrated circuitry humidity sensor, 0.050 in lead pitch SIP
HIH-4000-003	Integrated circuitry humidity sensor, 0.100 in lead pitch SIP with calibration and data printout
HIH-4000-004	Integrated circuitry humidity sensor, 0.050 in lead pitch SIP with calibration and data printout

WARRANTY/REMEDY

Honeywell warrants goods of its manufacture as being free of defective materials and faulty workmanship. Honeywell's standard product warranty applies unless agreed to otherwise by Honeywell in writing; please refer to your order acknowledgement or consult your local sales office for specific warranty details. If warranted goods are returned to Honeywell during the period of coverage, Honeywell will repair or replace, at its option, without charge those items it finds defective. **The foregoing is buyer's sole remedy and is in lieu of all other warranties, expressed or implied, including those of merchantability and fitness for a particular purpose. In no event shall Honeywell be liable for consequential, special, or indirect damages.**

While we provide application assistance personally, through our literature and the Honeywell web site, it is up to the customer to determine the suitability of the product in the application.

Specifications may change without notice. The information we supply is believed to be accurate and reliable as of this printing. However, we assume no responsibility for its use.

Automation and Control Solutions

Sensing and Control

Honeywell

11 West Spring Street

Freeport, Illinois 61032

www.honeywell.com/sensing

WARNING

MISUSE OF DOCUMENTATION

- The information presented in this product sheet is for reference only. Do not use this document as a product installation guide.
- Complete installation, operation, and maintenance information is provided in the instructions supplied with each product.

Failure to comply with these instructions could result in death or serious injury.

WARNING

PERSONAL INJURY

DO NOT USE these products as safety or emergency stop devices or in any other application where failure of the product could result in personal injury.

Failure to comply with these instructions could result in death or serious injury.

SALES AND SERVICE

Honeywell serves its customers through a worldwide network of sales offices, representatives and distributors. For application assistance, current specifications, pricing or name of the nearest Authorized Distributor, contact your local sales office or:

E-mail: info.sc@honeywell.com

Internet: www.honeywell.com/sensing

Phone and Fax:

Asia Pacific +65 6355-2828
+65 6445-3033 Fax
Europe +44 (0) 1698 481481
+44 (0) 1698 481676 Fax
Latin America +1-305-805-8188
+1-305-883-8257 Fax
USA/Canada +1-800-537-6945
+1-815-235-6847
+1-815-235-6545 Fax

Honeywell