

- High Temperature Radial Type, 105°C, 2000 hours assured Load Life.
- Applications: Communications equipment, switching regulators, and industrial applications.

Characteristics

Voltage Range	6.3 to 100 VDC				160 to 450 VDC				
Capacitance Range	0.47 to 10000uF				0.47 to 220uF				
Temperature Range	-40 to +105°C				-25 to +105°C				
Capacitance Tolerance	+20% -20% (at 20°C, 120Hz)								
Leakage Current	I≤0.01CV or 3uA, whichever is greater 2 minutes after Rated Voltage applied				I≤0.03CV or 3uA, whichever is greater 2 minutes after Rated Voltage applied				
Dissipation Factor	Rated Voltage (V)	6.3	10	16	25	35	50	63	
	Dissipation Factor(tanδ)max	0.22	0.20	0.16	0.14	0.12	0.10	0.09	
	Rated Voltage (V)	100	160	200	250	350	400	450	
	Dissipation Factor(tanδ)max	0.08	0.15	0.15	0.20	0.20	0.24	0.24	
For capacitance > 1000uF, add 0.02 for every 1000uF, (at 20°C, 120Hz)									
Stability at Low Temperature	Impedance ration at 120Hz								
	Rated Voltage (V)	6.3V	10V	16V	25-100V	160-250V	350-400V	450V	
	Z-25°C/Z 20°C	4	3	2	2	3	6	15	
	Z-40°C/Z 20°C	8	6	4	3	—	—	—	
Load Life	After the rated voltage has been applied for 2000 hours at 105°C		Capacitance change		Within ±20% of initial value				
			D.F. tanδ		150% of less of initial specified value				
			Leakage current		Initial specified value of less				
Shelf Life	After storage for 1000 hours at 105°C, with no voltage applied and being stabilized at +20°C, Capacitor shall meet the limit specified in load life.								

Case Size of Standard Products & Maximum Ripple Current (mA rms 105°C 120Hz)

Cap. ^{WV} uF	6.3V		10V		16V		25V		35V		50V		63V	
	Size	R.C.	Size	R.C.	Size	R.C.	Size	R.C.	Size	R.C.	Size	R.C.	Size	R.C.
0.47											5x11	8	5x11	8
1											5x11	12	5x11	12
2.2											5x11	20	5x11	20
3.3											5x11	25	5x11	28
4.7											5x11	30	5x11	34
10					5x11	35	5x11	38	5x11	41	5x11	46	5x11	50
22					5x11	54	5x11	57	5x11	61	5x11	68	6.3x11	82
33					5x11	64	5x11	69	5x11	75	6.3x11	90	6.3x11	100
47			5x11	70	5x11	100	5x11	105	6.3x11	110	6.3x11	125	8x12	135
100	5x11	95	5x11	105	5x11	125	6.3x11	135	8x12	170	8x12	180	10x13	225
220	5x11	160	6.3x11	175	6.3x11	215	8x12	230	10x13	300	10x16	345	10x21	400
330	6.3x11	195	8x12	245	8x12	260	10x13	335	10x16	400	10x21	460	13x21	540
470	6.3x11 8x12	230 270	8x12	290	8x12 10x13	310 370	10x13 10x16	410 440	10x21	520	10x21 13x21	600 610	13x26	700
1000	10x13	460	10x13	550	10x16 10x21	590 640	10x21 13x21	710 770	13x26	920	16x26	1080	16x32	1210
2200	10x21	810	10x21	860	13x21	1000	13x26 16x26	1090 1170	16x26 16x32	1290 1350	16x36	1530	18x36	1610
3300	13x21	960	13x21	1100	16x26	1300	16x26	1460	16x36	1650	18x36	1750		
4700	13x26	1330	13x26	1350	16x26	1600	16x36	1780	18x36	1900				
6800	13x26	1450	16x26	1670	16x32	1900	18x36	1950						
10000	16x26	1680	16x36	1900	18x36	2060								

Cap. uF	100V		160V		200V		250V		350V		400V		450V	
	Size	R.C.	Size	R.C.	Size	R.C.	Size	R.C.	Size	R.C.	Size	R.C.	Size	R.C.
0.47	5x11	10	5x11	12	5x11	12	5x11	12	6.3x11	13	6.3x11	14	6.3x11	14
1	5x11	15	6.3x11	17	6.3x11	17	6.3x11	17	6.3x11	20	8x12	20	8x12	20
2.2	5x11	23	6.3x11	25	6.3x11	25	8x12	29	8x12	35	10x13	35	10x13	35
3.3	5x11	32	6.3x11	32	8x12	35	8x12	42	10x13	47	10x13	47	10x16	54
4.7	5x11	37	8x12	42	8x12	50	10x13	50	10x16	55	10x16	55	10x21	60
10	6.3x11	56	10x13	59	10x16	60	10x16	64	10x21	79	10x21 13x21	80 110	13x26	87
22	8x12	96	10x16	105	10x16 10x21	105 130	10x21 13x21	110 140	13x21 13x26	130 160	13x26 16x26	145 160	16x26 16x32	165
33	10x13	120	10x21	125	13x21	140	13x21	140	16x26	195	16x26	195	16x36	210
47	10x16	160	13x21	165	13x26	165	13x26 16x26	180 220	16x32	230	16x32 16x36	250 275	16x36 18x32	260 290
100	13x21	245	13x26 16x26	270 310	16x26	285	16x32	365	18x36	375	18x36	360		
220	13x26 16x26	450 520	16x36	480	18x41	550								
330	16x26	690	18x36	705										
470	16x32	860	18x41	860										

Diagram of dimensions

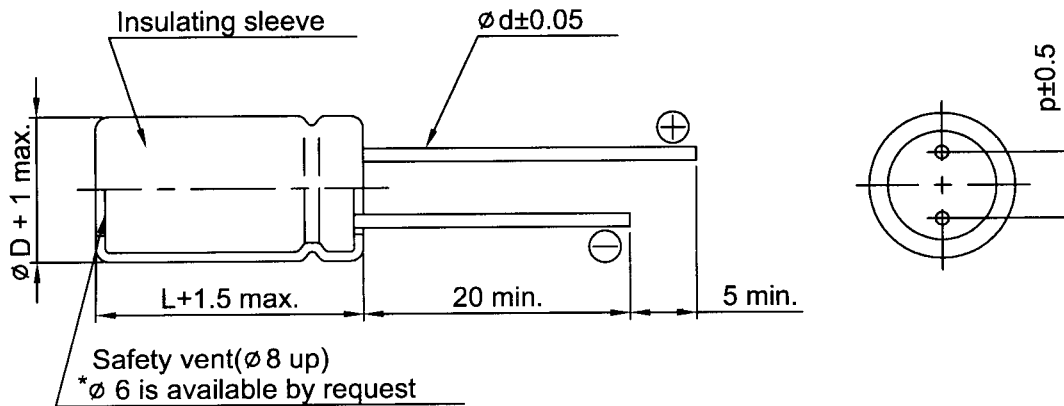

D ϕ	5	6	8	10	13	16	18
F	2.0	2.5	3.5	5	5	7.5	7.5
d ϕ	0.5		0.6			0.8	