

Data Sheet

Customer: _____

Product: Thick Film Chip Resistor. High Surge HSR Series _____

Size : 0603/0805/1206/1210/2512 _____

Issued Date: 15-Mar.-2019 _____

Edition: Ver. 3 _____

Record of change

Date	Ver.	Description	Page
1-Apr.-2015	1	Revised available tolerance	2
15-Jul.-2016	2	Add surge duration curve	2
15-Mar.-2019	3	Revised power rating and available tolerance	

HITANO ENTERPRISE CORP.

7F-7, No. 3, Wu Chuan 1st Road, New Taipei Industrial Park,

New Taipei City, TAIWAN, R.O.C.

Tel: +886 2 2299 1331 (Rep.)

Fax: +886 2 2298 2466, 2298 2969

Prepared by	Checked by	Approved by	Accepted by (customer)
1-Apr.-2015	1-Apr.-2015	1-Apr.-2015	
<i>Andy Hsu</i>	<i>Hwa Wu</i>	<i>Hwa Wu</i>	

THICK FILM SURGE CHIP RESISTORS HSR SERIES

■ Features

- Small size and lightweight with size range per int'l standard
- Highly stable in auto-placement surface mounting application
- Suitable for withstanding circuit for surge voltage

■ Applications

- CD-ROM
- Power supply
- Automotive industry
- Measurement instrument
- Medical or Military equipment
- Electronic watch and camera

■ Configuration

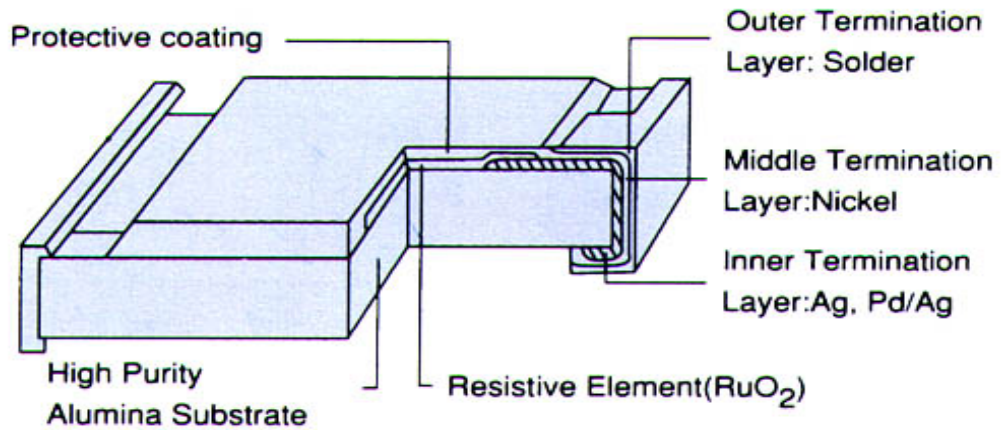

■ Dimensions

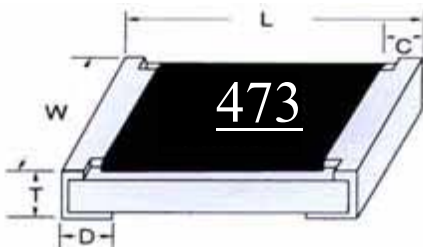

Size	L	W	C	D	T
0603	1.60±0.10	0.80±0.10	0.30±0.20	0.30±0.20	0.45±0.10
0805	2.00±0.10	1.25±0.10	0.40±0.20	0.40±0.20	0.50±0.10
1206	3.10±0.10	1.60±0.10	0.50±0.25	0.50±0.25	0.55±0.10
1210	3.10±0.10	2.60±0.10	0.50±0.25	0.50±0.25	0.55±0.10
2010	5.00±0.20	2.50±0.20	0.65±0.25	0.60±0.25	0.60±0.10
2512	6.40±0.20	3.10±0.20	0.60±0.25	1.80±0.25	0.60±0.15

Unit(mm)

■ Power Derating Curve

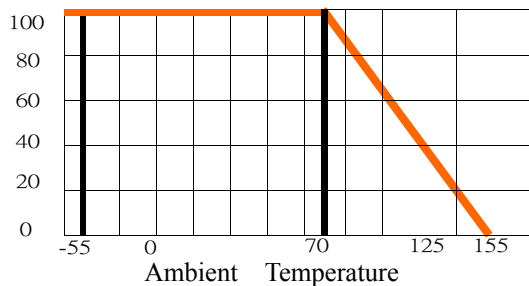

Maximum dissipation in percentage of rated power as a function of the ambient temperature for 0603,0805,1206,1210,2010,2512

THICK FILM SURGE CHIP RESISTORS HSR SERIES

■ Rating

Type	Size	Power Rating at 70°C	Max. RCWV	Max. Overload Voltage	Resistance Tolerance	Temperature Coefficient (ppm/°C)	Resistance Range		Standard Resistance Values
							Min.	Max.	
HSR0603	0603	1/8W	50V	100V	±1%(F)	±100ppm	10Ω	1MΩ	E96/E24
					±1%(F)	±200ppm	1Ω	9.76Ω	E96/E24
					±5%(J)	±200ppm	1Ω	1MΩ	E24
HSR0805	0805	1/4W	150V	300V	±1%(F)	±100ppm	10Ω	1MΩ	E96/E24
					±1%(F)	±150ppm	1Ω	9.76Ω	E96/E24
					±5%(J)	±200ppm	1Ω	1MΩ	E24
HSR1206	1206	1/2W	200V	400V	±1%(F)	±100ppm	1Ω	1MΩ	E96/E24
					±5%(J)	±200ppm	1Ω	1MΩ	E24
HSR1210	1210	1/2W	200V	400V	±1%(F)	±100ppm	1Ω	1MΩ	E96/E24
					±5%(J)	±200ppm	1Ω	1MΩ	E24
HSR2010	2010	1W	200V	400V	±1%(F)	±100ppm	1Ω	1MΩ	E96/E24
					±5%(J)	±200ppm	1Ω	1MΩ	E24
HSR2512	2512	2W	300V	600V	±1%(F)	±100ppm	1Ω	1MΩ	E96/E24
					±5%(J)	±200ppm	1Ω	1MΩ	E24

Type	Size	Description	Max. Rated Current	Resistance
HSR0603	0603	Zero Ohm , Jumper	≦ 2A	< 20mΩ
HSR0805	0805	Zero Ohm , Jumper	≦ 4A	< 20mΩ
HSR1206	1206	Zero Ohm , Jumper	≦ 4A	< 20mΩ
HSR1210	1210	Zero Ohm , Jumper	≦ 4A	< 20mΩ
HSR2010	2010	Zero Ohm , Jumper	≦ 6A	< 20mΩ
HSR2512	2512	Zero Ohm , Jumper	≦ 6A	< 20mΩ

Note : RCWV = (P×R)^{1/2} or Max. RCWV listed above, whichever is lower. RCWV : Working Voltage (V) , P : Rated Power (W) , R : Resistance Value (Ω) Solder-pad and trace size should be evaluated and board surface temperature should not exceed 105°C when applied full rated power.

THICK FILM SURGE CHIP RESISTORS HSR SERIES

■ Part Numbering

<u>HSR</u> Type	<u>0805</u> Size	<u>J</u> Tolerance	<u>R</u> Packing	<u>H</u> -	<u>47KR</u> Resistance(Ω) Resistance Value
	0603	F : ± 1%	R : Paper tape-5Kpcs	Standard	
	0805	J : ± 5%	K : Plastic tape-4Kpcs	H	For example
	1206			High Power	100R, 1KR, 10KR
	1210				100KR, 1MR
	2010				
	2512				

■ Resistor Marking

E24 ±5% : 3 Digits marking to identify the resistance value
0603/0805/1206/1210/2010/2512

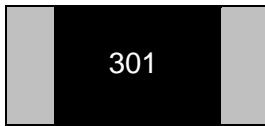

$$301 \rightarrow 30 \times 10^1 = 300\Omega$$

E24/E96 ±1% : 4 Digits marking to identify the resistance value
0805/1206/1210/2010/2512

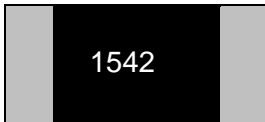

$$1542 \rightarrow 154 \times 10^2 = 15.4\text{K}\Omega$$

E24 ±1% : 3 Digits marking to identify the resistance value
 0603

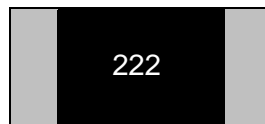

$$222 \rightarrow \times 10^2 = 2.2\text{K}\Omega$$

E96 ±1% : 3 Digits marking to identify the resistance value
 0603

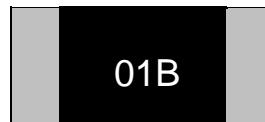

$$01\text{B} \rightarrow \text{Refer to 0603 marking table} = 1\text{K}\Omega$$

THICK FILM SURGE CHIP RESISTORS HSR SERIES

■ Tape And Reel Package

• Taping specs are according to EIA RS-481

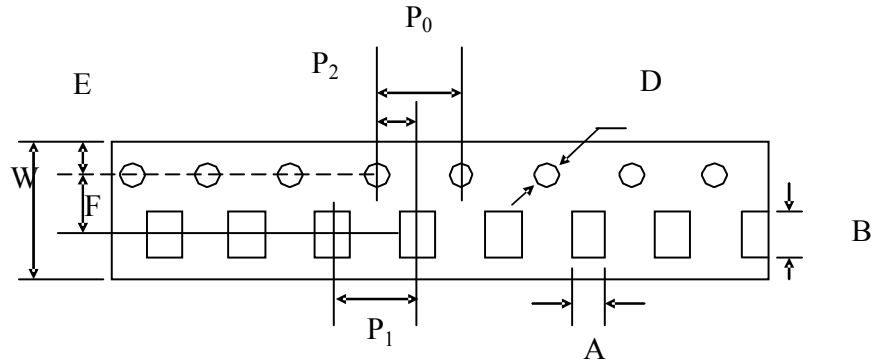

Accumulated dimensional tolerance 40±0.2mm

Size	A	B	W	F	E	P1	P2	P0	D
0603	1.10±0.20	1.90±0.20	8.00±0.30	3.50±0.05	1.75±0.10	4.00±0.10	2.00±0.05	4.00±0.10	1.50+0.10/-0
0805	1.65±0.20	2.40±0.20	8.00±0.30	3.50±0.05	1.75±0.10	4.00±0.10	2.00±0.05	4.00±0.10	1.50+0.10/-0
1206	2.00±0.20	3.60±0.20	8.00±0.30	3.50±0.05	1.75±0.10	4.00±0.10	2.00±0.05	4.00±0.10	1.50+0.10/-0
1210	3.00±0.20	3.60±0.20	8.00±0.30	3.50±0.05	1.75±0.10	4.00±0.10	2.00±0.05	4.00±0.10	1.50+0.10/-0
2010	2.80±0.20	5.50±0.20	12.00±0.30	5.50±0.05	1.75±0.10	4.00±0.10	2.00±0.05	4.00±0.10	1.50+0.10/-0
2512	3.50±0.20	6.70±0.20	12.00±0.30	5.50±0.05	1.75±0.10	4.00±0.10	2.00±0.05	4.00±0.10	1.50+0.10/-0

(unit: mm)

■ Reel Package

Size	Packaging Q'ty	A	N	C	D	B	G	T
0603 0805 1206 1210	5Kpcs / Reel	178.0±2.0	60.0±0.5	13.0±0.5	20min	2.0±0.5	10.0±1.5	14.9 max.
	10Kpcs / Reel	254.0±2.0	100.0±1.0	13.5±0.5	20min	2.0±0.5	10.0±1.5	14.9 max.
	20Kpcs / Reel	330.0±2.0	100.0±1.0	13.5±0.5	20min	2.0±0.5	10.0±1.5	14.9 max.
2010 2512	4Kpcs / Reel	178.0±2.0	60.0±0.5	13.0±0.5	20min	2.0±0.5	13.8±1.5	16.7 max.
	8Kpcs / Reel	254.0±2.0	100.0±1.0	13.5±0.5	20min	2.0±0.5	13.8±1.5	20.0 max.
	16Kpcs / Reel	330.0±2.0	100.0±1.0	13.5±0.5	20min	2.0±0.5	13.8±1.5	20.0 max.

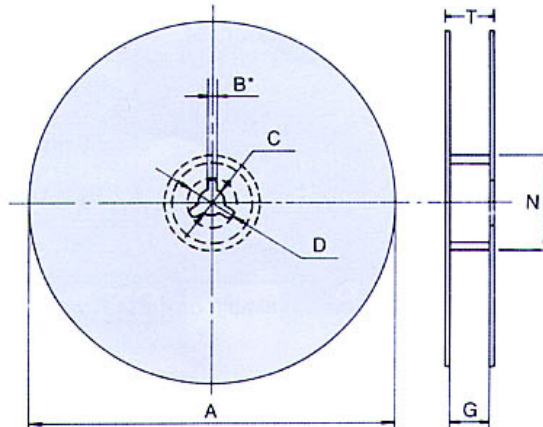

(unit: mm)



THICK FILM SURGE CHIP RESISTORS HSR SERIES

■ Specification And Test Methods

ITEM	SPECIFICATION	TEST METHOD
DC Resistance	F : ±1%, J : ±5%, K : ±10%, L : ±15%, M : ±20%	IEC 60115-1 4.5 / JIS C 5202 5.1 Measure the resistance value.
Short time Overload	$\Delta R \leq \pm (2\% + 0.1\Omega)$	IEC 60115-1 4.13 / JIS C 5202 5.5 2.5×Rated voltage or Max. Overload Voltage for 5 sec. measure resistance after 30 minutes
Solderability	Over 95% of termination must be covered with solder	IEC 60115-1 4.17 / JIS C 5202 6.5 After immersing flux, dip in the 235±2°C molten solder bath for 2±0.5 sec.
Resistance to Solder Heat	$\Delta R \leq \pm (1\% + 0.1\Omega)$ No mechanical damage	IEC 60115-1 4.18 / JIS C 5202 6.4 With 260±5°C for 10±1 sec.
Temperature Coefficient of Resistance (TCR)	±100 ppm/°C	IEC 60115-1 / JIS C 5201-1, Clause 4.8 Test temperature : 25°C (T1) → -55°C (T2) 25°C (T1) → +155°C (T2) $TCR (ppm/^{\circ}C) = \frac{R2-R1}{R1} \times \frac{1}{T2-T1} \times 10^6$ T1: 25°C T2: Test temperature R1: Resistance at reference temperature (T1) R2: Resistance at test temperature (T2)
Load Life Humidity	$\Delta R \leq \pm (3\% + 0.1\Omega)$	IEC 60115-1 4.24.2 / JIS C 5202 7.9 Maintain the temperature of the resistor at 40±2°C and 90~95% R.H. with the rated voltage applied. Cycle ON for 1.5 hours and OFF for 0.5 hour for 1000+48/-0 hours. After 1~4 hour, measure the resistance value.
Load Life	$\Delta R \leq \pm (3\% + 0.1\Omega)$	IEC 60115-1 4.25.1 / JIS C 5202 7.10 Permanent resistance change after 1000+48/-0 hours (1.5 hours ON, 0.5 hour OFF) at RCWV or Max. Keep the resistor at 70±2°C ambient
Intermittent Overload	$\Delta R \leq \pm (5\% + 0.1\Omega)$ No mechanical damage	JIS C 5202 5.8 4.0×Rated voltage (Max. Overload Voltage) 1 sec ON, 25 sec OFF, test 10,000 cycles
Temperature Cycle	$\Delta R \leq \pm (1\% + 0.1\Omega)$ No mechanical damage	IEC 60115-1 4.19 / JIS C 5202 7.4 Repeat 5 cycles as follows -55°C (30 min.) + 25°C (2~3 min.) +155°C (30 min.) + 25°C (2~3 min.)
Insulation Resistance	Between termination and coating must be over 1000MΩ	IEC 60115-1 4.6.1.1 / JIS C 5202 5.6 Test voltage: 100±15V
Bending Strength	$\Delta R \leq \pm (1\% + 0.1\Omega)$ No mechanical damage	IEC 60115-1 4.33 Resistance change after bended on the 90mm PCB. Bend: 3mm for 0603、0805, 2mm for 1206, 2010, 2512

THICK FILM SURGE CHIP RESISTORS HSR SERIES

■ Soldering Temperature Curve

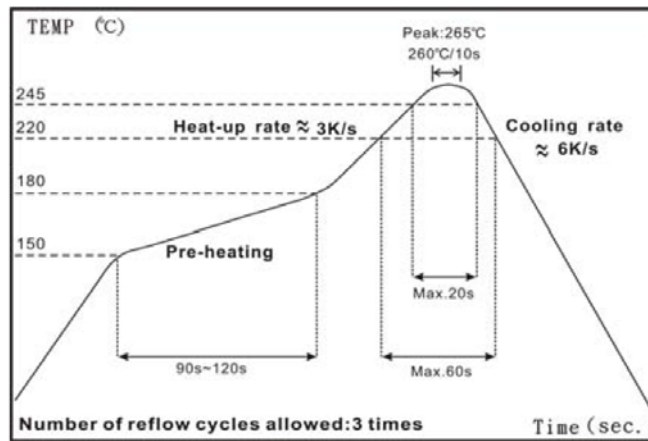
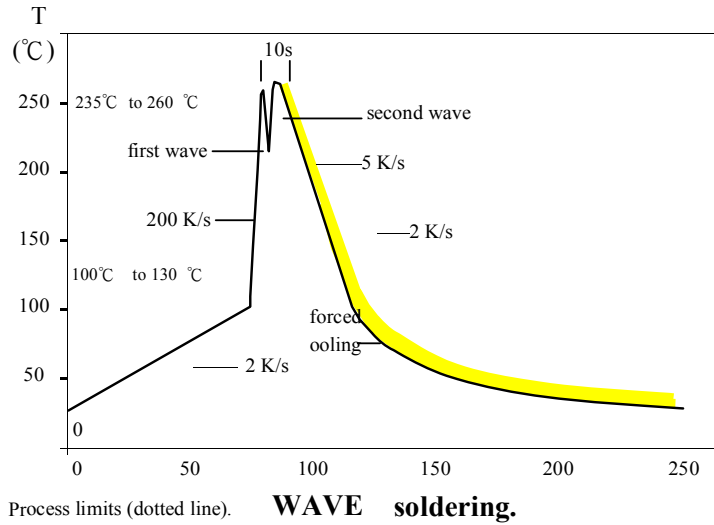

IR Reflow Soldering

■ Surge Performance

