

DF11 SERIES

2 mm Grid Double-Row Connectors (Approved by UL & CSA)

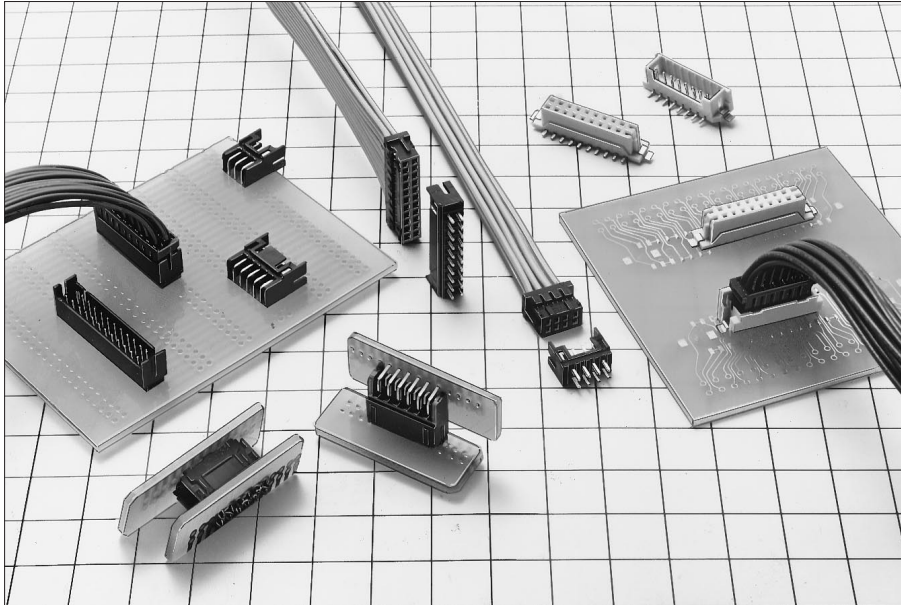

■ Features

1. Saves space on board

Two rows of 2 mm wide terminals are arranged compactly in a 5 mm width. Doubles the quantity of signals to handle per unit space as compared with the conventional one-row 2 mm wide terminal arrangement.

2. Many variations

Compatible with the crimp and insulation displacement termination. Available in the forms of board-to-cable, extension, and board-to-board, thereby expanding the freedom of board designing.

Choose either gold-plating or tin-plating to suit your application. Also, SMT-compatible connectors are available.

3. Wide range of applicable cables

Compact design of 2 mm and 2 rows, and applicable for AWG22 - AWG30.

4. Insulation displacement termination saves connection work

The fully-automatic insulation displacement terminator makes light work of laborious multi-harnessing (branch connection) and eliminates manual work process.

■ Application

OA equipment such as copying machines.

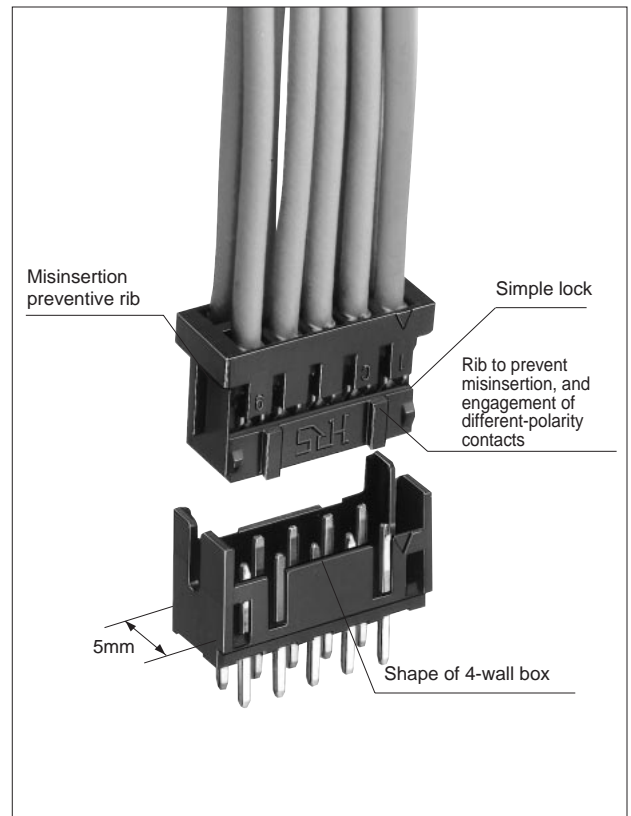

■ Features of the DF11 insulation displacement terminator (Single-core fully-automatic insulation displacement terminator AM700/DF11)

● Five major features of the AM7700/DF11 insulation displacement terminator

1. Multi-harnessing (branch connection)
2. Greatly reduces the set-up time (within 10 minutes).
3. Space-saving design (almost half of the conventional area)
4. Low cost reduces the risk of introduction.
5. Harness data can be saved to floppy and easily changed.

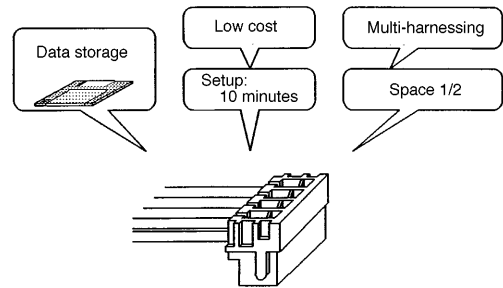

■ Key points

The DF11 insulation displacement terminator performs two-row insulation displacement connection with one-point parts, and completes the harnessing simply by connection to the machine. Also facilitates stock control of one-point parts.

■ Product standard

Rating	Rated current (Note 1)	Crimping	Wire size			Operating temp.	-30~85°C (Note 2)
		ID termination	AWG 22~26 : 2A	AWG 28 : 1A	AWG 30 : 0.5A	Operating humidity	40~80%
Rated voltage	Crimping	AC250V	ID termination	AC100V	Storage temp.	-10~60°C (Note 3)	Storage humidity 40~70% (Note 3)
			AWG 26, 28 : 1A				

Approved by UL-CSA Safety Standard			
Rating	Rated current	Wire size	
	Rated voltage	AC30V	
		AWG 22 : 2A	
		AWG 24~28 : 1A	
		AWG 30 : 0.5A	

■ UL & CAS Safety Standards File No.
 UL : E52653
 CSA : LR95109

Item	Standard	Conditions	
1. Insulation resistance	1000 MΩ or more	Measured at 500 VDC	
2. Withstand voltage	No flashover or dielectric breakdown allowed	AC650V 1 minute	
3. Contact resistance	30 mΩ or less	Measured at 100 mA	
4. Insertion and withdrawals force	MIN 0.3 N(30gf), MAX 4.4 N(450gf)	To be measured with a steel pin of □0.5±0.002mm	
5. Vibration resistance	No electrical discontinuity of 1 μs or more allowed	Frequency: 10 - 55 Hz, single-side amplitude: 0.75 mm, 3 directions for 2 hours	
6. Moisture resistance	Contact resistance: 30 mΩ or less, insulation resistance: 500 MΩ or more	Temperature: 40±2°C, humidity: 90 - 95%, allow 96 hours before measurement	
7. Temperature cycle	Contact resistance: 30 mΩ or less, insulation resistance: 1000 MΩ or more	(-55°C for 30 min. → 5 - 35°C for 10 min. → 85°C for 30 min. → 5 - 35°C for 10 min.) 5 cycles	
8. Insertion/extraction life	Contact resistance: 30 mΩ or less	Soldered-plate: 30 insertions/extractions	Gold-plate: 50 insertions/extractions
9. Solder heat resistance	No melting of resin affecting the connector performance allowed	Dip type	Flow: 250°C for 5 min. Manual soldering: solder temperature: 300°C for 2 seconds
		SMT type	Reflow: At recommended Manual soldering: solder temperature: 300°C for 3 seconds

Note 1: The rated current varies depending on the size of wire connected to the connector. The rating of the header itself is 2 A.

Note 2: Includes temperature rise when power is on.

Note 3: "Storage" refers to a long period of storage without use of the product before being mounted on a board.

The operating temperature and humidity ranges apply to the connectors mounted on a board when turned off, and connectors under temporary storage such as those being transported.

Note 4: The above standards are typical for the DF11 series. The formal standards are stated in the delivery specifications.

Material

Product	Part	Material	Processing	UL Rating
Crimp socket	Insulation	Polyamide resin	Black	UL94V-0
Crimp terminal for socket	Terminal	Phosphor bronze	Tin-plated or Gold-plated	
ID termination socket	Insulation	Polyamide resin	Black	UL94V-0
	Terminal	Phosphor bronze	Tin-plated or Gold-plated	
Receptacle	Insulation	Polyamide resin	Black	UL94V-0
	Terminal	Phosphor bronze	Tin-plated or Gold-plated	
Pin Header	Insulation	Polyamide resin	Black	UL94V-0
	Terminal	Brass	Tin-plated or Gold-plated	
S M T pin header	Insulation	Polyamide resin	Beige	UL94V-0
	Terminal	Brass	Tin-plated or Gold-plated	
	Fittings	Brass	Tin-plated	
Extension plug	Insulation	Polyamide resin	Black	UL94V-0
Crimp terminal for extension plug	Terminal	Phosphor bronze	Tin-plated or Gold-plated	
Extension adaptor	Insulation	Polyamide resin	Black	UL94V-0
	Terminal	Brass	Tin-plated	

Note : Our tin plating is protected from whiskers.

Structure of the product number

The product specifications can be determined from the product number.

When ordering, select products using the product numbers listed in this catalog 83 to 90 pages.

● Connector

$$\frac{\text{DF}}{\text{①}} \frac{\text{11}}{\text{②}} - \frac{*}{\text{③}} \frac{\text{DS}}{\text{④}} - \frac{\text{2C}}{\text{⑤ ⑥}}$$

① Series Name : DF	⑥ Connection form/Type of termination C : Crimp case R26 : ID termination socket for AWG26 R28 : ID termination socket for AWG28 DSA : Straight dip DS : Right angle dip V : Straight SMT A : Adaptor
② Series No. : 11	
③ Number of contacts : 4~32	
④ Types of connectors DS : Double-row socket DP : Double-row pin header DEP : Double-row extension plug	
⑤ Contact pitch : 2mm	

● Terminal

$$\text{DF11} - \frac{\text{EP}}{\text{①}} \frac{\text{2428}}{\text{②}} \frac{\text{PCFA}}{\text{③ ④}}$$

① Applicable form EP : Extension	③ Type of form/Type of packaging SCF : Socket contact, Reel SC : Socket contact, Loose piece PCF : Plug contact, Reel PC : Plug contact, Loose piece
② Applicable wire size 22 : AWG22 2428 : AWG24~28 30 : AWG30	
	④ Type of plating Blank : Tin-plated A : Gold-plated

Insulation displacement termination socket

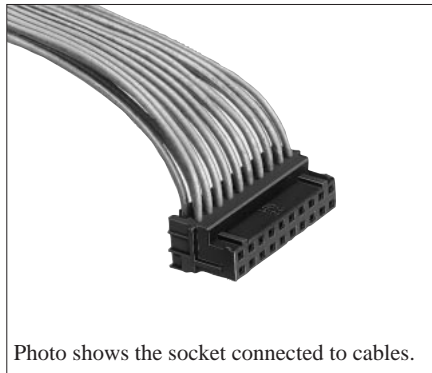
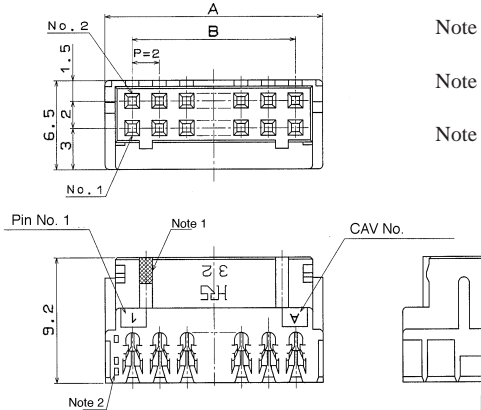

Photo shows the socket connected to cables.



Note 1: White mark discriminates between the R26 and R28 (provided for the D28 only).

Note 2: One square hole indicates an odd row and two square holes indicate an even row.

Note 3: Use the following models of DIP type headers:

- Straight-type: DF11-***DP-2DSA (08)
- Angle-type: DF11-***DP-2DS (24)

[Specification No.]: -****, (****)

Blank: Tin-plated, 100 pcs. per pack

(20): Tin-plated, magazine packaging

For AWG26

Unit : mm

HRS No.	Product No.	No. of contacts	A	B	No. of products in a magazine
543-0652-0- <i>**</i>	DF11- 4DS-2R26(<i>**</i>)	4	6.0	2.0	188
543-0653-3- <i>**</i>	DF11- 6DS-2R26(<i>**</i>)	6	8.0	4.0	140
543-0654-6- <i>**</i>	DF11- 8DS-2R26(<i>**</i>)	8	10.0	6.0	112
543-0655-9- <i>**</i>	DF11-10DS-2R26(<i>**</i>)	10	12.0	8.0	94
543-0656-1- <i>**</i>	DF11-12DS-2R26(<i>**</i>)	12	14.0	10.0	80
543-0657-4- <i>**</i>	DF11-14DS-2R26(<i>**</i>)	14	16.0	12.0	70
543-0658-7- <i>**</i>	DF11-16DS-2R26(<i>**</i>)	16	18.0	14.0	62
543-0659-0- <i>**</i>	DF11-18DS-2R26(<i>**</i>)	18	20.0	16.0	56
543-0660-9- <i>**</i>	DF11-20DS-2R26(<i>**</i>)	20	22.0	18.0	50
543-0661-1- <i>**</i>	DF11-22DS-2R26(<i>**</i>)	22	24.0	20.0	46
543-0662-4- <i>**</i>	DF11-24DS-2R26(<i>**</i>)	24	26.0	22.0	42
543-0663-7- <i>**</i>	DF11-26DS-2R26(<i>**</i>)	26	28.0	24.0	40
543-0664-0- <i>**</i>	DF11-28DS-2R26(<i>**</i>)	28	30.0	26.0	36
543-0665-2- <i>**</i>	DF11-30DS-2R26(<i>**</i>)	30	32.0	28.0	34
543-0666-5- <i>**</i>	DF11-32DS-2R26(<i>**</i>)	32	34.0	30.0	32

For AWG28

Unit : mm

HRS No.	Product No.	No. of contacts	A	B	No. of products in a magazine
543-0667-8- <i>**</i>	DF11- 4DS-2R28(<i>**</i>)	4	6.0	2.0	188
543-0668-0- <i>**</i>	DF11- 6DS-2R28(<i>**</i>)	6	8.0	4.0	140
543-0669-3- <i>**</i>	DF11- 8DS-2R28(<i>**</i>)	8	10.0	6.0	112
543-0670-2- <i>**</i>	DF11-10DS-2R28(<i>**</i>)	10	12.0	8.0	94
543-0671-5- <i>**</i>	DF11-12DS-2R28(<i>**</i>)	12	14.0	10.0	80
543-0672-8- <i>**</i>	DF11-14DS-2R28(<i>**</i>)	14	16.0	12.0	70
543-0673-0- <i>**</i>	DF11-16DS-2R28(<i>**</i>)	16	18.0	14.0	62
543-0674-3- <i>**</i>	DF11-18DS-2R28(<i>**</i>)	18	20.0	16.0	56
543-0675-6- <i>**</i>	DF11-20DS-2R28(<i>**</i>)	20	22.0	18.0	50
543-0676-9- <i>**</i>	DF11-22DS-2R28(<i>**</i>)	22	24.0	20.0	46
543-0677-1- <i>**</i>	DF11-24DS-2R28(<i>**</i>)	24	26.0	22.0	42
543-0678-4- <i>**</i>	DF11-26DS-2R28(<i>**</i>)	26	28.0	24.0	40
543-0679-7- <i>**</i>	DF11-28DS-2R28(<i>**</i>)	28	30.0	26.0	36
543-0680-6- <i>**</i>	DF11-30DS-2R28(<i>**</i>)	30	32.0	28.0	34
543-0681-9- <i>**</i>	DF11-32DS-2R28(<i>**</i>)	32	34.0	30.0	32

Note 1: Models without a number specified are available in packs (100 units per pack). Order them in packs.

Note 2: DF11 single core sockets for fully-automatic insulation displacement terminators are available in magazine packs with HRS numbers followed by the suffix (20).

Note 3: Order magazine packaged sockets in integral multiples of the amount contained in a magazine

Applicable cable

Product No.	Applicable cable	Coating diameter
DF11- <i>*</i> DS-2R26	UL1061 AWG26 (7/0.16)	ø0.9 ~1.05mm
DF11- <i>*</i> DS-2R28	UL1061 AWG28 (7/0.127)	ø0.85~0.95mm

DF11-***DS-2R terminator

Type	Product No.	Connection	Remarks
Single core fully automatic insulation displacement terminator	AM700/DF11	<ul style="list-style-type: none"> ■ Applicable harness forms <ol style="list-style-type: none"> ① DF11-both ends, one end ② DF11-DF11 branch ③ DF11-DF3 branch ■ Applicable harness length 100~2000mm ■ Equipped with a conductivity inspection mechanism 	(20) magazine packaging applies to the connectors.
Desk-top insulation displacement terminator	SA700/DF11	<ul style="list-style-type: none"> ■ DF11: Without restrictions 	Desk-top machine for small lots

Crimp socket

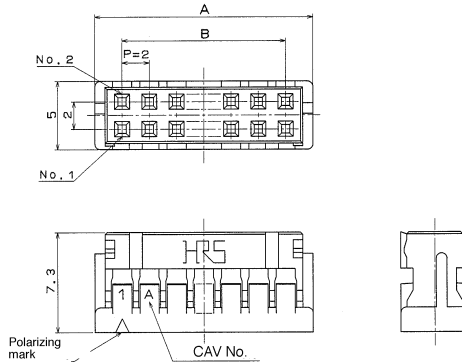
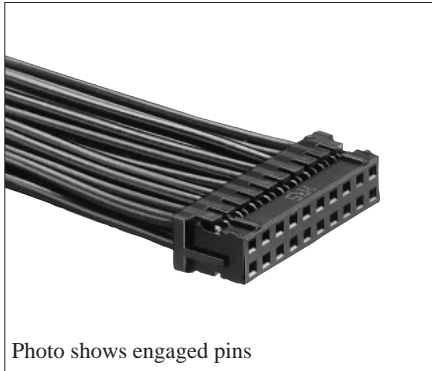

[Specification No.]: -**, (**)
 Blank : 100 pcs. per pack
 (40) : 500 pcs. per package
 (41) : 1000 pcs. per package

Unit: mm

HRS No.	Product No.	No. of contacts	A	B	HRS No.	Product No.	No. of contacts	A	B
543-0568-6-*	DF11- 4DS-2C(**)	4	6.0	2.0	543-0509-7-*	DF11-20DS-2C(**)	20	22.0	18.0
543-0502-8-*	DF11- 6DS-2C(**)	6	8.0	4.0	543-0510-6-*	DF11-22DS-2C(**)	22	24.0	20.0
543-0503-0-*	DF11- 8DS-2C(**)	8	10.0	6.0	543-0511-9-*	DF11-24DS-2C(**)	24	26.0	22.0
543-0504-3-*	DF11-10DS-2C(**)	10	12.0	8.0	543-0512-1-*	DF11-26DS-2C(**)	26	28.0	24.0
543-0505-6-*	DF11-12DS-2C(**)	12	14.0	10.0	543-0513-4-*	DF11-28DS-2C(**)	28	30.0	26.0
543-0506-9-*	DF11-14DS-2C(**)	14	16.0	12.0	543-0514-7-*	DF11-30DS-2C(**)	30	32.0	28.0
543-0507-1-*	DF11-16DS-2C(**)	16	18.0	14.0	543-0515-0-*	DF11-32DS-2C(**)	32	34.0	30.0
543-0508-4-*	DF11-18DS-2C(**)	18	20.0	16.0					

Note 1: Minimum order quantity of the models without a number specified is one pack containing 100 sockets.

Note 2: Models available in (40): 500 pieces per package and (41): 1000 pieces per pack should be ordered in quantity of sockets. Order in multiples of order units, e.g., 500, 1000, 1500,-- .

Receptacle (DIP)

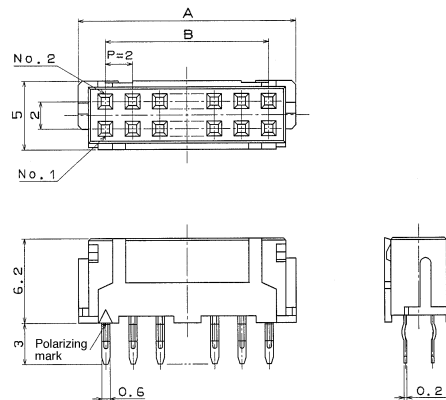
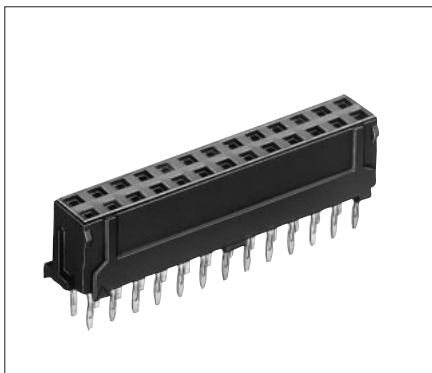

[Specification No.]: -**, (**)
 Blank : Tin-plated, 100 pcs. per pack
 (01) : Gold-plated, 100 pcs. per pack

- Board through-hole diameter : $\varnothing 0.8 \pm 0.1$
- Effective diameter for fixing a kink temporarily : $\varnothing 0.8 \pm 0.05$

Unit: mm

HRS No.	Product No.	No. of contacts	A	B	HRS No.	Product No.	No. of contacts	A	B
543-0553-9-*	DF11- 6DS-2DSA(**)	6	8.0	4.0	543-0560-4-*	DF11-20DS-2DSA(**)	20	22.0	18.0
543-0554-1-*	DF11- 8DS-2DSA(**)	8	10.0	6.0	543-0561-7-*	DF11-22DS-2DSA(**)	22	24.0	20.0
543-0555-4-*	DF11-10DS-2DSA(**)	10	12.0	8.0	543-0562-0-*	DF11-24DS-2DSA(**)	24	26.0	22.0
543-0556-7-*	DF11-12DS-2DSA(**)	12	14.0	10.0	543-0563-2-*	DF11-26DS-2DSA(**)	26	28.0	24.0
543-0557-0-*	DF11-14DS-2DSA(**)	14	16.0	12.0	543-0564-5-*	DF11-28DS-2DSA(**)	28	30.0	26.0
543-0558-2-*	DF11-16DS-2DSA(**)	16	18.0	14.0	543-0565-8-*	DF11-30DS-2DSA(**)	30	32.0	28.0
543-0559-5-*	DF11-18DS-2DSA(**)	18	20.0	16.0	543-0566-0-*	DF11-32DS-2DSA(**)	32	34.0	30.0

Note : Minimum order quantity of the models without a number and (01)specified are available in packs (100 units per pack). Order them in packs.

Receptacle (SMT)

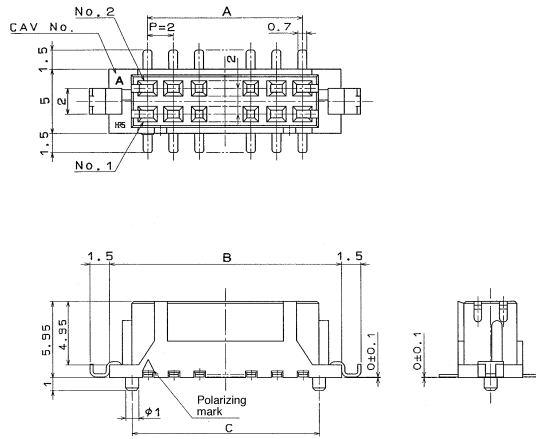
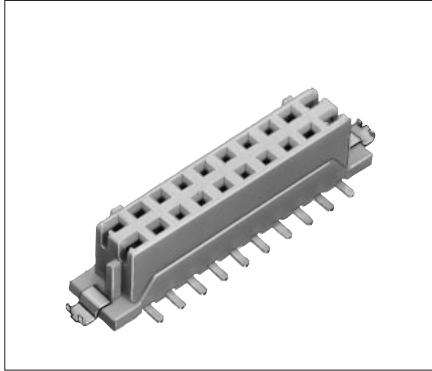

Unit: mm

HRS No.	Product No.	No. of contacts	A	B	C	D	No. of products in a magazine
543-0569-9-**-	DF11- 4DS-2V(**)	4	2.0	8.5	4.5	8.7	41
543-0570-8-**-	DF11- 6DS-2V(**)	6	4.0	10.5	6.5	10.7	35
543-0571-0-**-	DF11- 8DS-2V(**)	8	6.0	12.5	8.5	12.7	30
543-0572-3-**-	DF11-10DS-2V(**)	10	8.0	14.5	10.5	14.7	27
543-0573-6-**-	DF11-12DS-2V(**)	12	10.0	16.5	12.5	16.7	24
543-0574-9-**-	DF11-14DS-2V(**)	14	12.0	18.5	14.5	18.7	22
543-0575-1-**-	DF11-16DS-2V(**)	16	14.0	20.5	16.5	20.7	20
543-0576-4-**-	DF11-18DS-2V(**)	18	16.0	22.5	18.5	22.7	18
543-0577-7-**-	DF11-20DS-2V(**)	20	18.0	24.5	20.5	24.7	17
543-0578-0-**-	DF11-22DS-2V(**)	22	20.0	26.5	22.5	26.7	16
543-0579-2-**-	DF11-24DS-2V(**)	24	22.0	28.5	24.5	28.7	15
543-0580-1-**-	DF11-26DS-2V(**)	26	24.0	30.5	26.5	30.7	14
543-0581-4-**-	DF11-28DS-2V(**)	28	26.0	32.5	28.5	32.7	13
543-0582-7-**-	DF11-30DS-2V(**)	30	28.0	34.5	30.5	34.7	12
543-0583-0-**-	DF11-32DS-2V(**)	32	30.0	36.5	32.5	36.7	12
543-0584-2-**-	DF11-40DS-2V(**)	40	38.0	44.5	40.5	44.7	10

[Specification No.]: -**,(**)
 (20) : Tin-plated, magazine packaging
 (50) : Gold-plated, magazine packaging

(Note 2)

Note 1: Order magazine packaged sockets in integral multiples of the amount contained in a magazine.
 Note 2: 40-pin products are available in combinations of SMT-compatible parts only.

Recommended board pattern

Magazine dimensional drawing

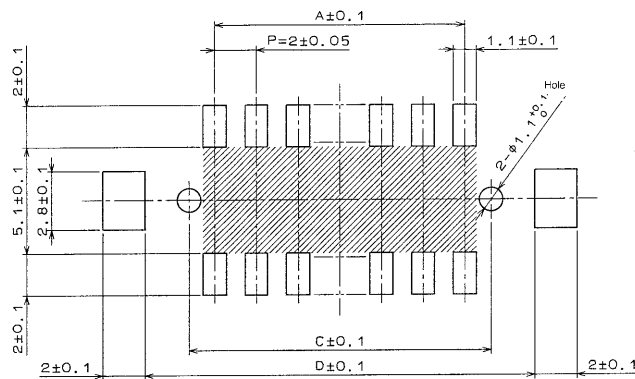

Note: When a part marked with has a pattern and no resist on it, use care to prevent the connector terminal from contacting it.

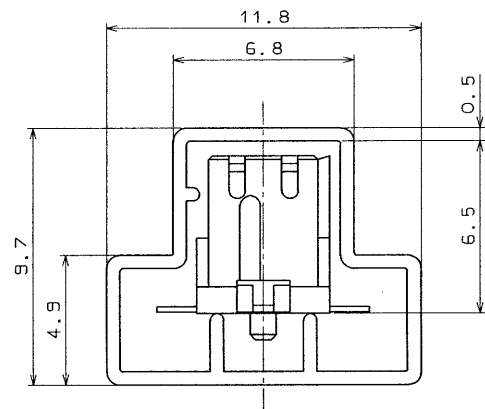

■ Straight pin header

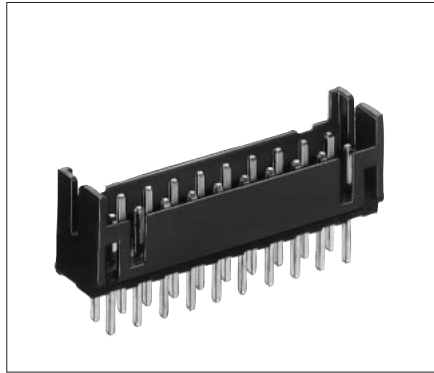

● Board through-hole diameter : $\varnothing 0.8 \pm 0.1$

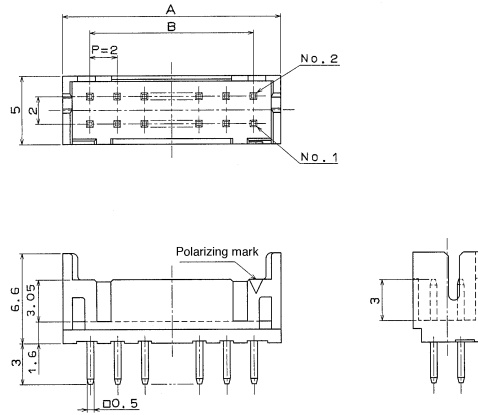

[Specification No.]: -**,(**)
 Blank : Tin-plated
 (01) : Gold-plated
 (08) : Tin-plated, low-insertion/
 extraction force type
 (Tin-plated recommended
 specification)
 (20) : Tin-plated, magazine
 packaging

Unit: mm

HRS No.	Product No.	No. of contacts	A	B	No. of products in a magazine	HRS No.	Product No.	No. of contacts	A	B	No. of products in a magazine
543-0517-5-**-**	DF11- 4DP-2DSA(**)	4	6.0	2.0	81	543-0525-3-**-**	DF11-20DP-2DSA(**)	20	22.0	18.0	22
543-0518-8-**-**	DF11- 6DP-2DSA(**)	6	8.0	4.0	61	543-0526-6-**-**	DF11-22DP-2DSA(**)	22	24.0	20.0	20
543-0519-0-**-**	DF11- 8DP-2DSA(**)	8	10.0	6.0	49	543-0527-9-**-**	DF11-24DP-2DSA(**)	24	26.0	22.0	18
543-0520-0-**-**	DF11-10DP-2DSA(**)	10	12.0	8.0	40	543-0528-1-**-**	DF11-26DP-2DSA(**)	26	28.0	24.0	17
543-0521-2-**-**	DF11-12DP-2DSA(**)	12	14.0	10.0	34	543-0529-4-**-**	DF11-28DP-2DSA(**)	28	30.0	26.0	16
543-0522-5-**-**	DF11-14DP-2DSA(**)	14	16.0	12.0	30	543-0530-3-**-**	DF11-30DP-2DSA(**)	30	32.0	28.0	15
543-0523-8-**-**	DF11-16DP-2DSA(**)	16	18.0	14.0	27	543-0531-6-**-**	DF11-32DP-2DSA(**)	32	34.0	30.0	14
543-0524-0-**-**	DF11-18DP-2DSA(**)	18	20.0	16.0	24						

Note 1: Minimum order quantity of the models without a number, (01) and (08) specified are available in packs. (100 units per pack)

Note 2: Order magazine packaged sockets in integral multiples of the amount contained in a magazine.

■ Right angle pin header



● Board through-hole diameter : $\varnothing 0.8 \pm 0.1$

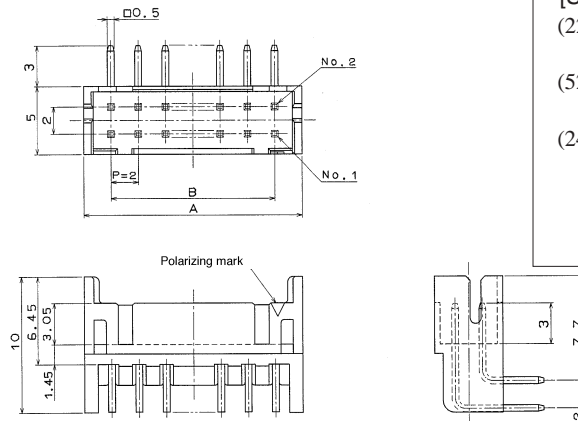

[Specification No.]: -**,(**)
 (22) : Tin-plated, magazine
 packaging
 (52) : Gold-plated, magazine
 packaging
 (24) : Tin-plated, low-insertion/
 extraction force type
 (Tin-plated recommended
 specification)

Unit: mm

HRS No.	Product No.	No. of contacts	A	B	No. of products in a magazine	HRS No.	Product No.	No. of contacts	A	B	No. of products in a magazine
543-0533-1-**-**	DF11- 4DP-2DS(**)	4	6.0	2.0	81	543-0541-0-**-**	DF11-20DP-2DS(**)	20	22.0	18.0	22
543-0534-4-**-**	DF11- 6DP-2DS(**)	6	8.0	4.0	61	543-0542-2-**-**	DF11-22DP-2DS(**)	22	24.0	20.0	20
543-0535-7-**-**	DF11- 8DP-2DS(**)	8	10.0	6.0	48	543-0543-5-**-**	DF11-24DP-2DS(**)	24	26.0	22.0	18
543-0536-0-**-**	DF11-10DP-2DS(**)	10	12.0	8.0	40	543-0544-8-**-**	DF11-26DP-2DS(**)	26	28.0	24.0	17
543-0537-2-**-**	DF11-12DP-2DS(**)	12	14.0	10.0	34	543-0545-0-**-**	DF11-28DP-2DS(**)	28	30.0	26.0	16
543-0538-5-**-**	DF11-14DP-2DS(**)	14	16.0	12.0	30	543-0546-3-**-**	DF11-30DP-2DS(**)	30	32.0	28.0	15
543-0539-8-**-**	DF11-16DP-2DS(**)	16	18.0	14.0	27	543-0547-6-**-**	DF11-32DP-2DS(**)	32	34.0	30.0	14
543-0540-7-**-**	DF11-18DP-2DS(**)	18	20.0	16.0	24						

Note : Order magazine packaged sockets in integral multiples of the amount contained in a magazine.

■ Straight pin header (SMT)

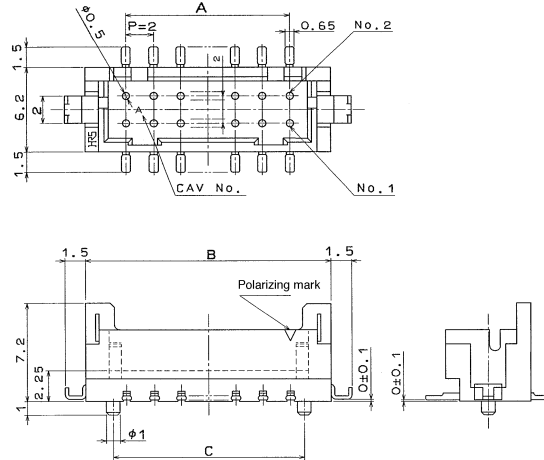
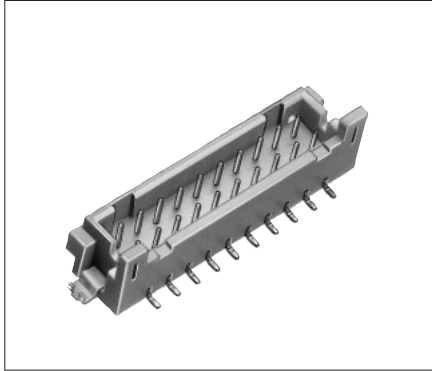

Unit: mm

HRS No.	Product No.	No. of contacts	A	B	C	D	No. of products in a magazine
543-0585-5-**-	DF11- 4DP-2V(**)	4	2.0	8.5	4.0	8.7	41
543-0586-8-**-	DF11- 6DP-2V(**)	6	4.0	10.5	6.0	10.7	35
543-0587-0-**-	DF11- 8DP-2V(**)	8	6.0	12.5	8.0	12.7	30
543-0588-3-**-	DF11-10DP-2V(**)	10	8.0	14.5	10.0	14.7	27
543-0589-6-**-	DF11-12DP-2V(**)	12	10.0	16.5	12.0	16.7	24
543-0590-5-**-	DF11-14DP-2V(**)	14	12.0	18.5	14.0	18.7	22
543-0591-8-**-	DF11-16DP-2V(**)	16	14.0	20.5	16.0	20.7	20
543-0592-0-**-	DF11-18DP-2V(**)	18	16.0	22.5	18.0	22.7	18
543-0593-3-**-	DF11-20DP-2V(**)	20	18.0	24.5	20.0	24.7	17
543-0594-6-**-	DF11-22DP-2V(**)	22	20.0	26.5	22.0	26.7	16
543-0595-9-**-	DF11-24DP-2V(**)	24	22.0	28.5	24.0	28.7	15
543-0596-1-**-	DF11-26DP-2V(**)	26	24.0	30.5	26.0	30.7	14
543-0597-4-**-	DF11-28DP-2V(**)	28	26.0	32.5	28.0	32.7	13
543-0598-7-**-	DF11-30DP-2V(**)	30	28.0	34.5	30.0	34.7	12
543-0599-0-**-	DF11-32DP-2V(**)	32	30.0	36.5	32.0	36.7	12
543-0600-7-**-	DF11-40DP-2V(**)	40	38.0	44.5	40.0	44.7	10

[Specification No.]: -**,(**)
 (20): Tin-plated, magazine packaging
 (50): Gold-plated, magazine packaging

(Note 2)

Note 1: Order magazine packaged sockets in integral multiples of the amount contained in a magazine.
 Note 2: 40-pin products are available in combinations of SMT-compatible parts only.

❖ Recommended board pattern

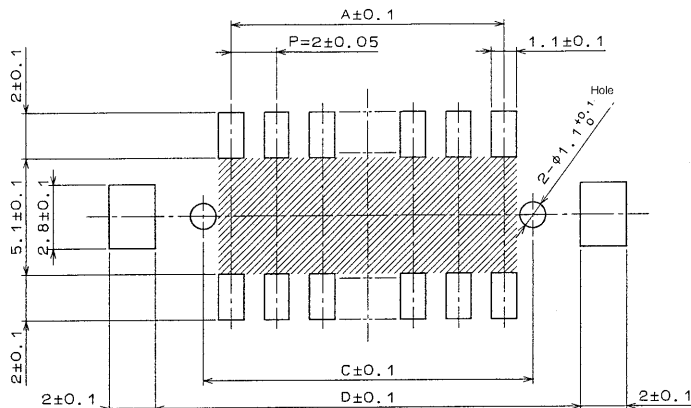

Note: When a part marked with has a pattern and no resist on it, use care to prevent the connector terminal from contacting it.

❖ Magazine dimensional drawing

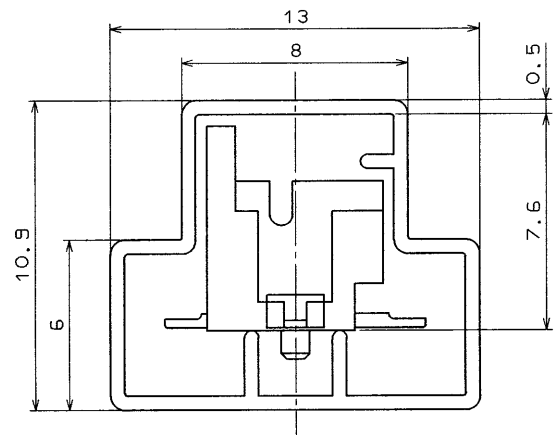

Extension plug

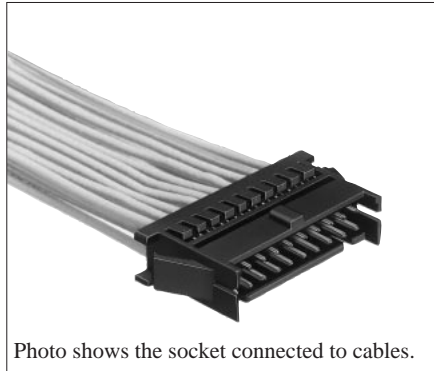
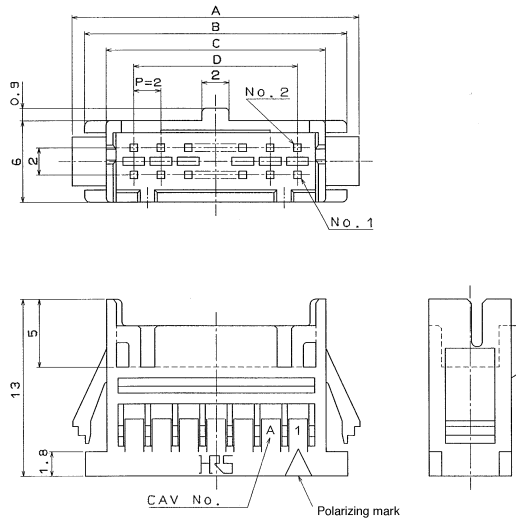
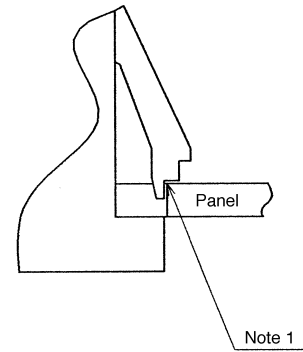
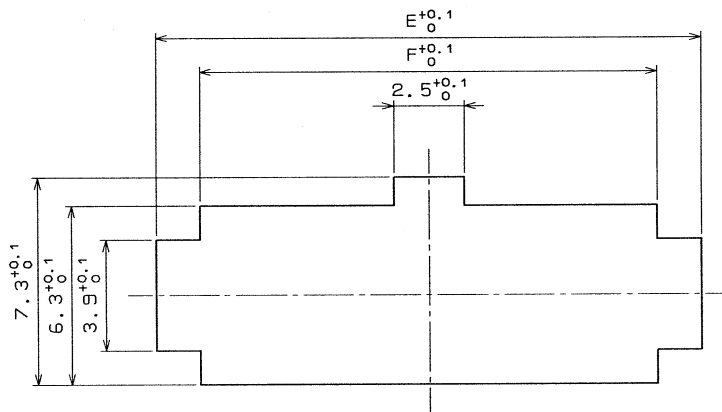

Photo shows the socket connected to cables.



Panel cutout dimensions for B extension plug



- Note 1: Use the sharp edge (without R) for engagement with the panel.
- Note 2: Applicable panel thickness: 1.6 ~ 1.0 mm (somewhat looseness will result when mounted on a panel of other than 1.6 or 1.2 mm in thickness).

Unit: mm

HRS No.	Product No.	No. of contacts	A	B	C	D	E	F
543-0619-5-**-	DF11- 4DEP-2C(**)	4	11.0	9.2	6.0	2.0	9.4	6.3
543-0620-4-**-	DF11- 6DEP-2C(**)	6	13.0	11.2	8.0	4.0	11.4	8.3
543-0621-7-**-	DF11- 8DEP-2C(**)	8	15.0	13.2	10.0	6.0	13.4	10.3
543-0622-0-**-	DF11-10DEP-2C(**)	10	17.0	15.2	12.0	8.0	15.4	12.3
543-0623-2-**-	DF11-12DEP-2C(**)	12	19.0	17.2	14.0	10.0	17.4	14.3
543-0624-5-**-	DF11-14DEP-2C(**)	14	21.0	19.2	16.0	12.0	19.4	16.3
543-0625-8-**-	DF11-16DEP-2C(**)	16	23.0	21.2	18.0	14.0	21.4	18.3
543-0626-0-**-	DF11-18DEP-2C(**)	18	25.0	23.2	20.0	16.0	23.4	20.3
543-0627-3-**-	DF11-20DEP-2C(**)	20	27.0	25.2	22.0	18.0	25.4	22.3
543-0628-6-**-	DF11-22DEP-2C(**)	22	29.0	27.2	24.0	20.0	27.4	24.3
543-0629-9-**-	DF11-24DEP-2C(**)	24	31.0	29.2	26.0	22.0	29.4	26.3
543-0630-8-**-	DF11-26DEP-2C(**)	26	33.0	31.2	28.0	24.0	31.4	28.3
543-0631-0-**-	DF11-28DEP-2C(**)	28	35.0	33.2	30.0	26.0	33.4	30.3
543-0632-3-**-	DF11-30DEP-2C(**)	30	37.0	35.2	32.0	28.0	35.4	32.3
543-0633-6-**-	DF11-32DEP-2C(**)	32	39.0	37.2	34.0	30.0	37.4	34.3

[Specification No.]: -**, (**)
 Blank : 100 pcs. per pack
 (40) : 500 pcs. packaging
 (41) : 1000 pcs. packaging

- Note 1: Minimum order quantity of the models without a number specified is one pack containing 100 sockets.
- Note 2: Models available in (40): 500 pieces per package and (41): 1000 pieces per pack should be ordered in quantity of sockets. Order in multiples of order units, e.g., 500, 1000, 1500,-- .

Terminal adapter

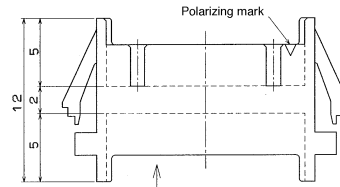
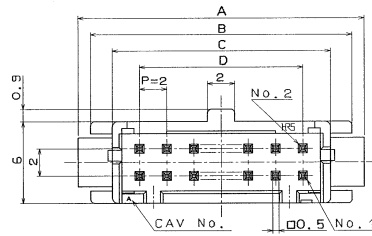
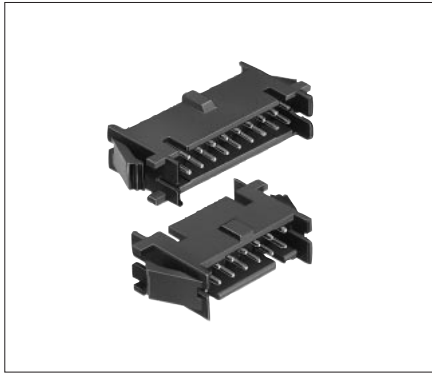

Note: Insertion and extraction force on this side is higher than the other.

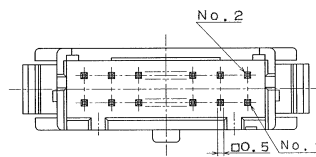

Panel cutout dimensions for B extension panel

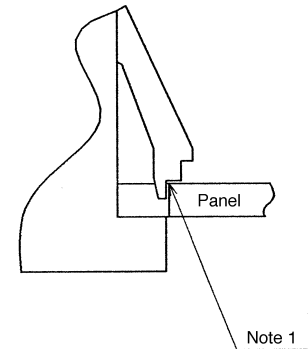
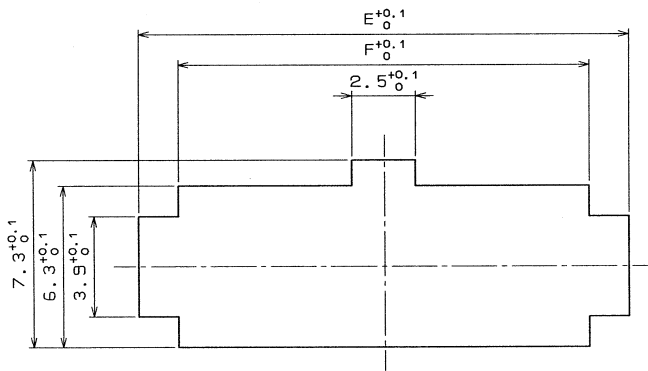

- Note 1: Use the sharp edge (without R) for engagement with the panel.
- Note 2: Applicable panel thickness: 1.6 ~ 1.0 mm (somewhat looseness will result when mounted on a panel of other than 1.6 or 1.2 mm in thickness).

Unit: mm

HRS No.	Product No.	No. of contacts	A	B	C	D	E	F
543-0698-1-**-	DF11- 4DEP-2A(**)	4	11.0	9.2	6.0	2.0	9.4	6.3
543-0699-4-**-	DF11- 6DEP-2A(**)	6	13.0	11.2	8.0	4.0	11.4	8.3
543-0700-1-**-	DF11- 8DEP-2A(**)	8	15.0	13.2	10.0	6.0	13.4	10.3
543-0701-4-**-	DF11-10DEP-2A(**)	10	17.0	15.2	12.0	8.0	15.4	12.3
543-0702-7-**-	DF11-12DEP-2A(**)	12	19.0	17.2	14.0	10.0	17.4	14.3
543-0703-0-**-	DF11-14DEP-2A(**)	14	21.0	19.2	16.0	12.0	19.4	16.3
543-0704-2-**-	DF11-16DEP-2A(**)	16	23.0	21.2	18.0	14.0	21.4	18.3
543-0705-5-**-	DF11-18DEP-2A(**)	18	25.0	23.2	20.0	16.0	23.4	20.3
543-0706-8-**-	DF11-20DEP-2A(**)	20	27.0	25.2	22.0	18.0	25.4	22.3
543-0707-6-**-	DF11-22DEP-2A(**)	22	29.0	27.2	24.0	20.0	27.4	24.3
543-0708-3-**-	DF11-24DEP-2A(**)	24	31.0	29.2	26.0	22.0	29.4	26.3
543-0709-6-**-	DF11-26DEP-2A(**)	26	33.0	31.2	28.0	24.0	31.4	28.3
543-0710-5-**-	DF11-28DEP-2A(**)	28	35.0	33.2	30.0	26.0	33.4	30.3
543-0711-8-**-	DF11-30DEP-2A(**)	30	37.0	35.2	32.0	28.0	35.4	32.3
543-0712-0-**-	DF11-32DEP-2A(**)	32	39.0	37.2	34.0	30.0	37.4	34.3

[Specification No.]: -**,(**)
Blank : 100 pcs. per pack

Note : Minimum order quantity of the models without a number specified is one pack containing 100 sockets.

Socket Crimp terminal

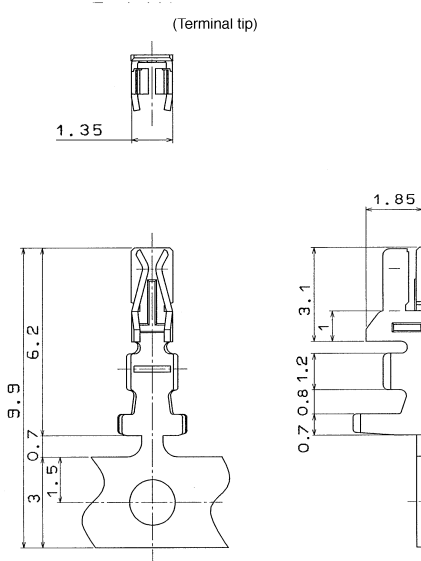

HRS No.	Product No.	Type	Quantity	Processing
543-0601-0	DF11 -22SCF	Reel terminal	10,000 units per reel	Tin-plated
543-0602-2	DF11 -22SC	Loose piece terminal	100 pcs. per pack	
543-0500-2	DF11 -2428SCF	Reel terminal	10,000 units per reel	
543-0501-5	DF11 -2428SC	Loose piece terminal	100 pcs. per pack	
543-0634-9	DF11A-2428SCF	Reel terminal	10,000 units per reel	
543-0635-1	DF11A-2428SC	Loose piece terminal	100 pcs. per pack	
543-0605-0	DF11 -30SCF	Reel terminal	10,000 units per reel	Gold-plated
543-0606-3	DF11 -30SC	Loose piece terminal	100 pcs. per pack	
543-0603-5	DF11 -22SCFA	Reel terminal	10,000 units per reel	
543-0604-8	DF11 -22SCA	Loose piece terminal	100 pcs. per pack	
543-0550-0	DF11 -2428SCFA	Reel terminal	10,000 units per reel	
543-0551-3	DF11 -2428SCA	Loose piece terminal	100 pcs. per pack	
543-0607-6	DF11 -30SCFA	Reel terminal	10,000 units per reel	Gold-plated
543-0608-9	DF11 -30SCA	Loose piece terminal	100 pcs. per pack	

Note : DF11A-2428SCF/SC is of tin-plated low insertion/extraction force type.

● Applicable wire (Tin-plated annealed copper wire)

● Recommended wire
UL1061, UL1007 (Note 2)

Conductor size (core construction)	Coating diameter
AWG 22 (17 core/0.16mm)	ø1.2~ø1.45mm
AWG 24 (11 core/0.16mm)	ø0.9~ø1.45mm
AWG 26 (7 core/0.16mm)	
AWG 28 (7 core/0.127mm)	
AWG 30 (7 core/0.1mm)	ø0.75~ø1.2mm

● Strip length
1.7~2.3mm

Crimp terminal for extension plug

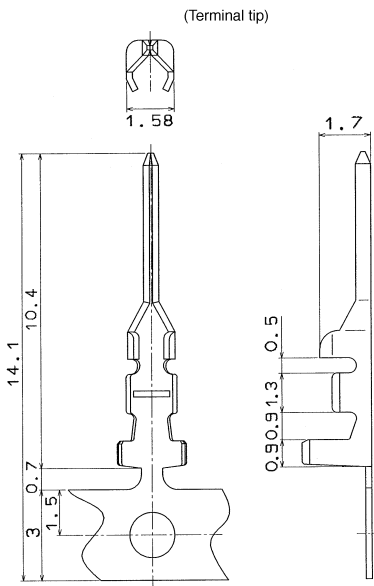

HRS No.	Product No.	Type	Quantity	Processing
543-0615-4	DF11-EP2428PCF	Reel terminal	10,000 units per reel	Tin-plated
543-0616-7	DF11-EP2428PC	Loose piece terminal	100 pcs. per pack	
543-0617-0	DF11-EP2428PCFA	Reel terminal	10,000 units per reel	Gold-plated
543-0618-2	DF11-EP2428PCA	Loose piece terminal	100 pcs. per pack	

● Applicable wire (Tin-plated annealed copper wire)

● Recommended wire
UL1061, UL1007

Conductor size (core construction)	Coating diameter
AWG 24 (11 core/0.16mm)	ø0.9~ø1.45mm
AWG 26 (7 core/0.16mm)	
AWG 28 (7 core/0.127mm)	

● Strip length
1.9~2.3mm

Note 1: Contact our sales department for unspecified wires.

Applicable crimping tool

Type	HRS No.	Product No.	Applicable contact
Applicator	901-4529-7	AP105-DF11-22S	DF11 -22SCF/SCFA
	901-4511-1	AP105-DF11-2428S	DF11 -2428SCF/SCFA DF11A-2428SCF
	901-4532-1	AP105-DF11-30S	DF11 -30SCF/SCFA
	901-4528-4	AP105-DF11-EP2428P	DF11 -EP2428PCF/PCFA
Press body	901-0005-4	CM-105	
Manual crimping tool	550-0228-6	DF11-TA22HC	DF11 -22SC/SCA
	550-0197-4	DF11-TA2428HC	DF11 -2428SC/SCA DF11A-2428SC
	550-0230-8	DF11-TA30HC	DF11 -30SC/SCA
	550-0227-3	DF11EP-TA2428HC	DF11 -EP2428PC/PCA
Extraction tool	550-0179-2	DF-C-PO(B)	DF11 -****SCF
			DF11 -EP****PCF

Note : We will not honor the warranty if a problem is caused by using a tool not approved by Hirose.

❖ Application drawing

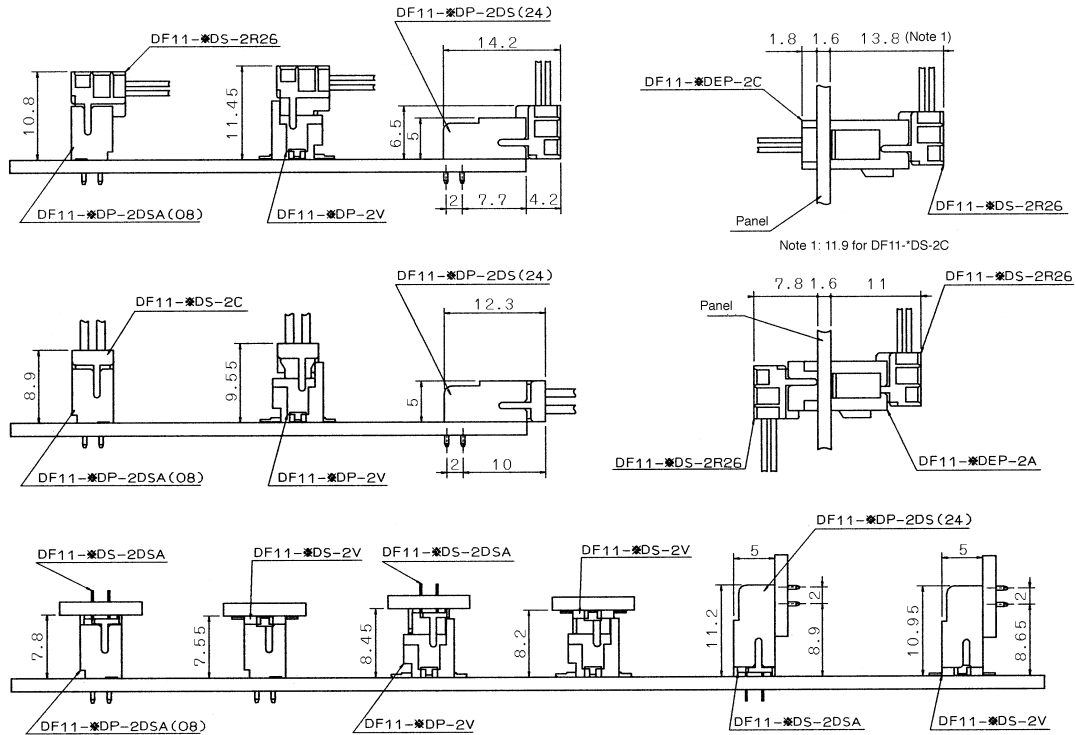

❖ Notes on use

<p>1. Recommended temperature profile (SMT)</p>	<p>IR reflow conditions</p> <table border="1"> <tr> <td>Preheating part</td> <td>150°C</td> <td>100 ~120 sec.</td> </tr> <tr> <td rowspan="2">Soldering part</td> <td>235 ± 5°C</td> <td>less than 10 sec.</td> </tr> <tr> <td>220°C or more</td> <td>10 ~ 30 sec.</td> </tr> </table> <p>Maximum 240°C 220°C</p> <p>Note 1: You can solder a product up to two times under the same conditions, provided that the product is allowed to cool back to room temperature before the second soldering. Note 2: The above temperature refers to the board surface temperature of the connector lead.</p>	Preheating part	150°C	100 ~120 sec.	Soldering part	235 ± 5°C	less than 10 sec.	220°C or more	10 ~ 30 sec.
Preheating part	150°C	100 ~120 sec.							
Soldering part	235 ± 5°C	less than 10 sec.							
	220°C or more	10 ~ 30 sec.							
<p>2. Recommended soldering conditions (SMT)</p>	<p>Soldering iron temperature: 290±10°C, soldering time: less than 3 seconds</p>								
<p>3. Recommended screen thickness (SMT)</p>	<p>0.15 mm ~ 0.2 mm</p>								
<p>4. Warp in board (SMT)</p>	<p>0.03 mm or less at the center of the connector with the connector ends as the reference.</p>								
<p>5. Recommended soldering condition (DIP)</p>	<ul style="list-style-type: none"> ■ Reflow conditions by automatic soldering machine: Soldering temperature: 250±5°C, for 3 seconds or less. ■ Manual soldering conditions: Soldering iron temperature: 290±10°C, soldering time: 2 second or less. 								
<p>6. Cleaning conditions</p>	<p>See "GUIDE TO HIROSE NYLON CONNECTORS."</p>								
<p>7. Connecting conditions</p>	<p>See "GUIDE TO HIROSE NYLON CONNECTORS."</p>								