

harmik[®] Miniature D connectors, 1.27 mm pitch

Page

I/O connectors **01.02**

Pin and socket



Technical characteristics	01.04
Connectors with straight solder pins	01.05
Connectors with right angled solder pins	01.07
Connectors with IDC flat cable termination	01.09
Connectors with IDC discrete wire termination	01.10

Bellows



Technical characteristics	01.12
Connectors with straight solder pins	01.13
Connectors with right angled solder pins	01.14
Connectors with IDC discrete wire termination	01.15
Connectors with solder cup	01.16

Hoods



Metal hoods	01.17
Plastic hoods	01.19

Accessories **01.20**

Intra cabinet connectors **01.21**

Pin and socket



Technical characteristics	01.22
Connectors with straight solder pins	01.23
Connectors with right angled solder pins	01.26
Connectors with IDC flat cable termination	01.27

for economical and reliable connections

harmik

A comprehensive range of high density interface connectors based on two mating design concepts:

- Blade and fork contact in the Pin/Socket range.
- Leaf contact in the Bellows range.

Available in a various number of contacts with options for secure locking of mated connectors in accordance with the following international standards:

- Small Computer System Interface
SCSI-2
SCSI-2 wide
SCSI-3
- Intelligent Peripheral Interface
IPI
- High Performance Peripheral Interface
HIPPI
- High Speed Serial Interface
HSSI
- Media Independent Interface
MII
- Bi-directional Parallel Interface
IEEE – 1284-C
- EIA – TIA
232-E
- IEC
61 076-3-101

UL recognised

For customer specific applications we can design and manufacture solutions to match your requirement.

Sales department
HARTING components



Certified according to EN ISO 9001 in design/development, production, installation and servicing

Bellows
with leaf contact design

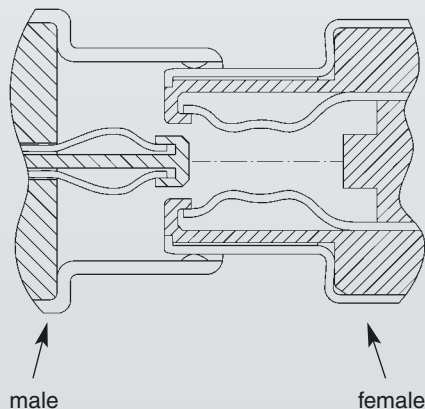

Pin and Socket
with blade and fork contact design

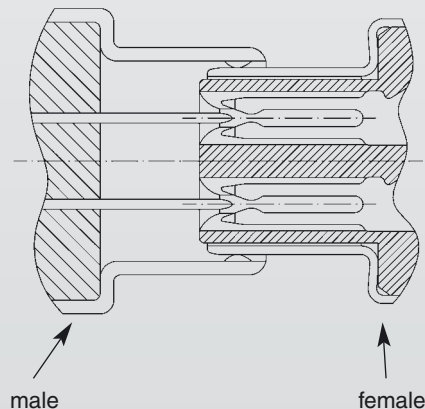

General information

It is the user's responsibility to check whether the components illustrated in this catalogue comply with different regulations from those stated in special fields of application which we are unable to foresee.

We reserve the right to modify designs in order to improve quality, keep pace with technological advancement or meet particular requirements in production.

This catalogue must not be used in any form or manner without our prior approval in writing (Copyright Law, Fair Trading Law, Civil Code). We are bound by the English version only.

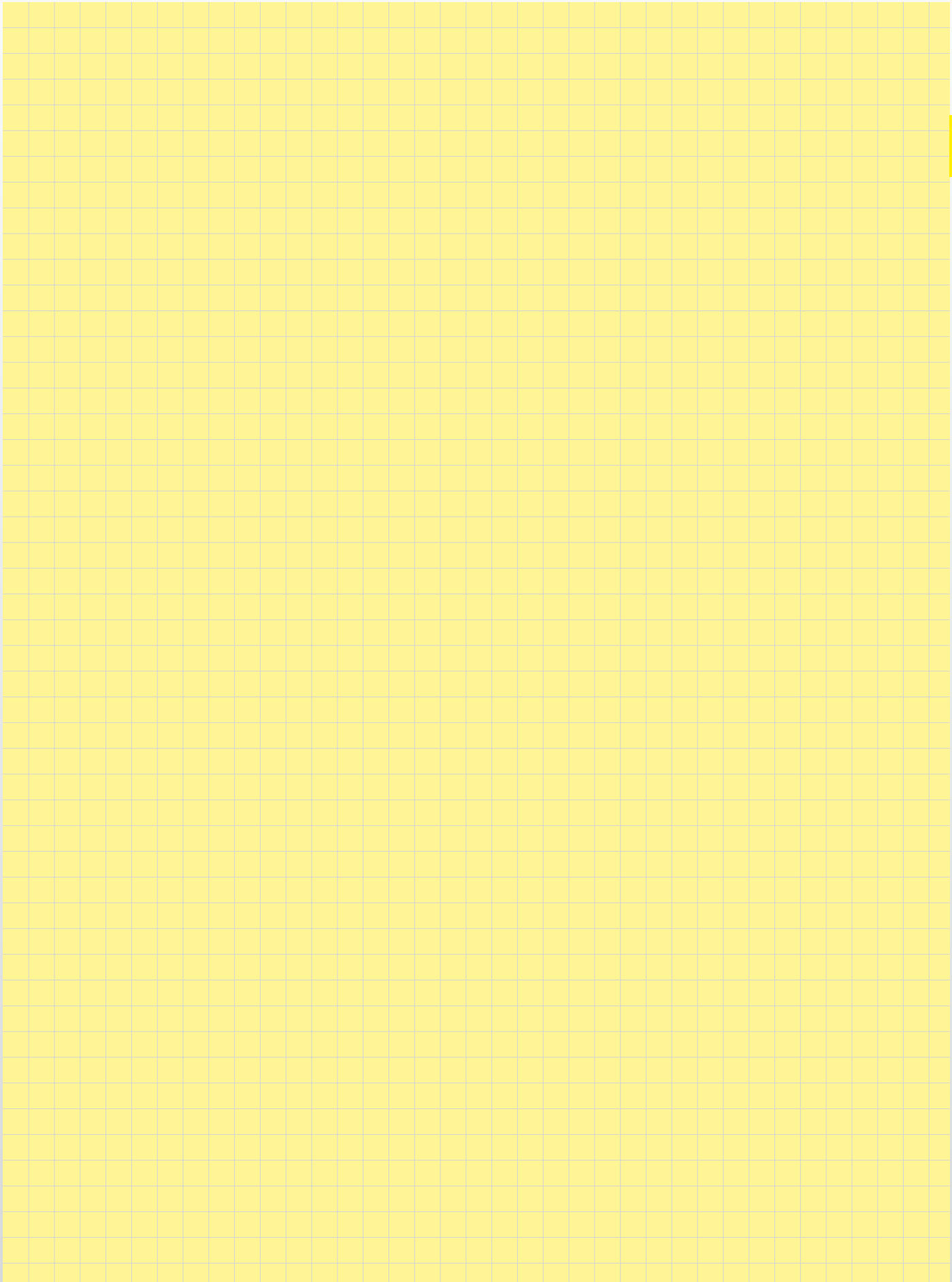

Number of contacts	20, 26, 28, 50, 68, 100
Pitch	1.27 mm
Working current	1 A
Working voltage	240 V ~
Test voltage $U_{r.m.s.}$	750 V
Contact resistance	$\leq 30 \text{ m}\Omega$
Insulation resistance	$\geq 10^3 \text{ M}\Omega$
Temperature range	-55 °C ... + 105 °C
Terminations	
Solder pins	Straight for pcb holes min. $\varnothing 0.74 \text{ mm}$ Angled 90° for pcb holes min. $\varnothing 0.74 \text{ mm}$
Insulation displacement	Discrete wire AWG 28 to AWG 30 max. section: 0.089 mm ² min. section: 0.050 mm ² Insulation \varnothing min. 0.50 mm \varnothing max. 0.88 mm Flat cable AWG 30 pitch 0.635 mm
Materials	
Moulding	Thermoplastic resin glass-fibre filled UL 94-V0 Liquid Crystal Polymer (LCP) for SCSI 3, straight
Contacts	Copper alloy
Contact surface	Selectively gold-plated
Metal shell	Die cast zamac or stamped steel, nickel-plated
Hoods	Die cast zamac, nickel-plated
	Thermoplastic resin nickel-plated, steel insert



Number of contacts

20–68



Female connectors, straight

har-mik

Identification	No. of contacts	Part No.
Female connectors with straight solder pins	20	60 01 020 5102
	26	60 01 026 5102
	28	60 01 028 5102
	50	60 01 050 5102
	68	60 01 068 5102

Dimensions

	a	b _{±0.1}	c	e	f	g	h
20	33.40	27.43	15.60	9 x 1.27 = 11.43	23.24	23.70	27.45
26	37.21	31.24	19.41	12 x 1.27 = 15.24	27.05	27.50	31.25
28	38.48	32.51	20.68	13 x 1.27 = 16.51	28.32	28.80	32.50
50	52.45	46.48	34.65	24 x 1.27 = 30.48	42.29	42.80	46.50
68	63.88	57.91	46.08	33 x 1.27 = 41.91	53.72	54.20	57.90

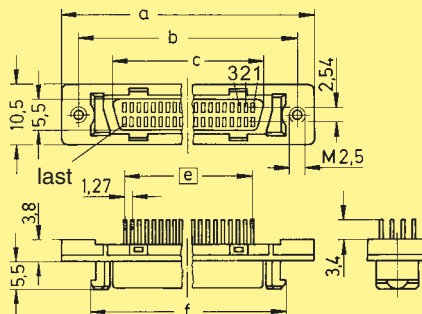

Board drillings

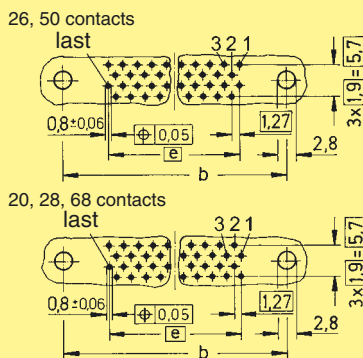

Panel cut out

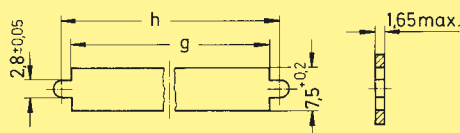

Dimensions in mm

Number of contacts

68

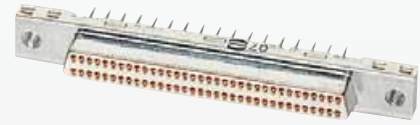

Female connectors, straight

Identification	No. of contacts	Part No.
Female connector with straight solder pins	68	60 02 068 5120

Dimensions

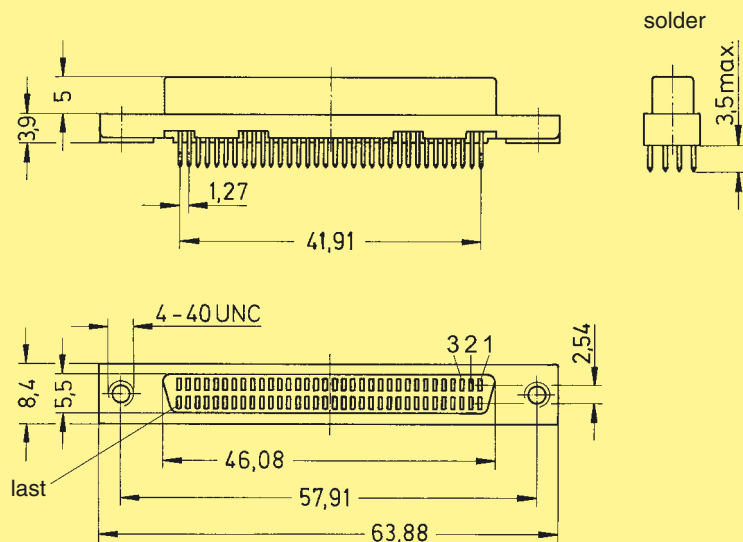

Board drillings
(Components side)

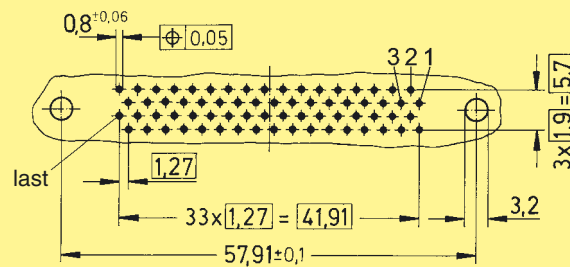

Dimensions in mm

Number of contacts

20–68



Female connectors, angled

Identification		No. of contacts	Part No.
Female connectors with angled solder pins		20	60 01 020 51 ..
		26	60 01 026 51 ..
		28	60 01 028 51 ..
		50	60 01 050 51 ..
		68	60 01 068 51 ..
Panel fixing	Board fixing		
M 2.5	M 2.5	32	
M 2.5	Board lock	40	

Dimensions

	a	b _{±0.1}	c	e	f	g	h
20	33.40	27.40	15.60	9 x 1.27 = 11.43	23.24	23.70	27.45
26	37.21	31.24	19.41	12 x 1.27 = 15.24	27.05	27.50	31.25
28	38.48	32.48	20.68	13 x 1.27 = 16.51	28.32	28.80	32.50
50	52.45	46.45	34.65	24 x 1.27 = 30.48	42.29	42.80	46.50
68	63.88	57.88	46.08	33 x 1.27 = 41.91	53.72	54.20	57.90

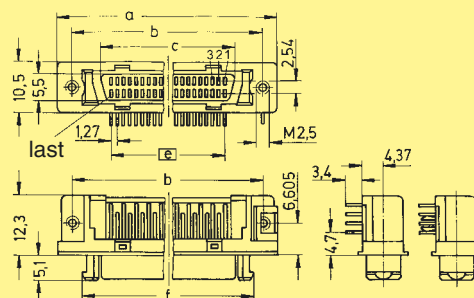

without board lock with board lock

Board drillings

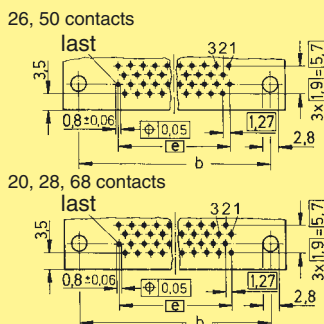

Panel cut out

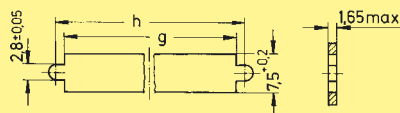

Dimensions in mm

har-mik

Number of contacts

68-100



Female connectors, angled

Identification	No. of contacts	Part No.	
Female connectors with angled solder pins	68	60 02 068 51 ...	
With female screw lock			41
Without female screw lock			50
With female screw lock	100	60 02 100 5141	

Dimensions

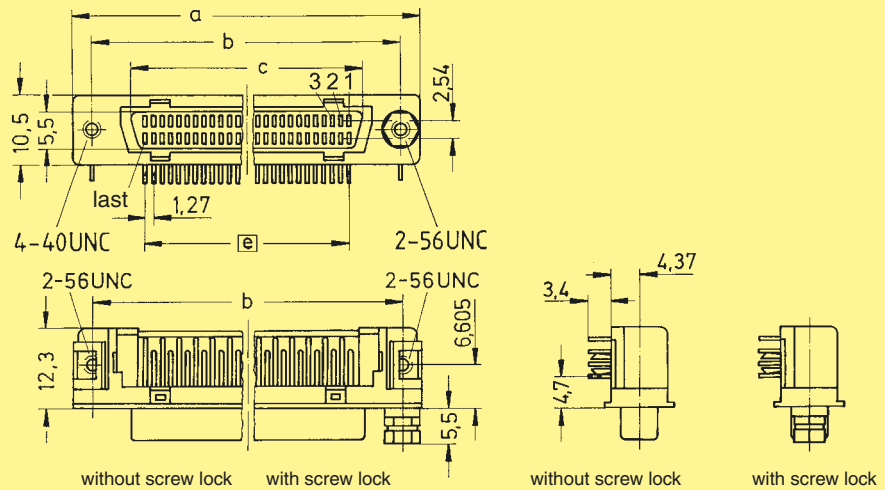

	a	b _{±0.1}	c	e
68	63.88	57.91	46.08	33 x 1.27 = 41.91
100	84.20	78.23	66.40	49 x 1.27 = 62.33

Board drillings
(Components side)

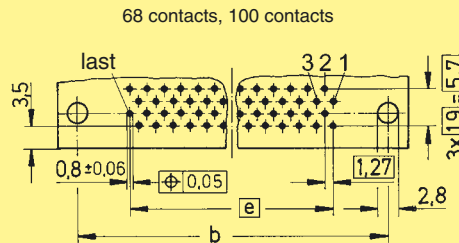

Panel cut out

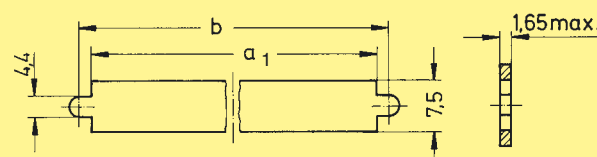

	a ₁	b
68	54.22	57.91
100	74.53	78.23

Dimensions in mm

Number of contacts

50-68



Female connectors for IDC flat cable, straight

Identification	No. of contacts	Part No.	
Female panel connectors with insulation displacement termination for IDC flat cable pitch 0.635 mm AWG 30		with latch system	with screw lock system
	50	60 04 050 5343	60 04 050 5344
	68	60 04 068 5343	60 04 068 5344

Dimensions for connectors with latch system

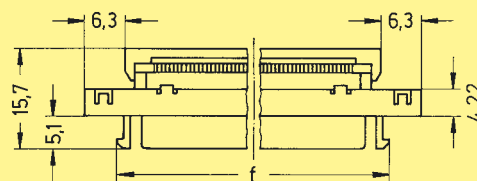
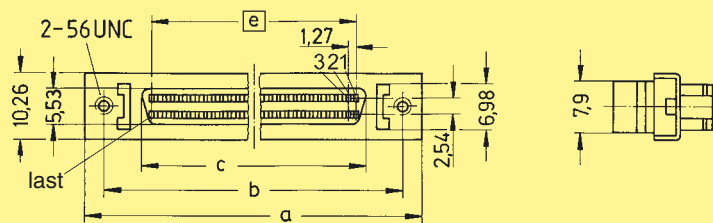

Panel cut out

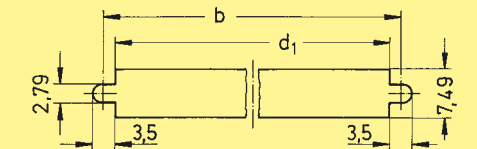

	a	b	c	d ₁	d ₂	e	f
50	52.45	46.48	34.70	42.80	42.30	30.48	42.30
68	63.88	57.91	46.13	54.23	53.72	41.91	53.72

Dimensions for connectors with screw lock system

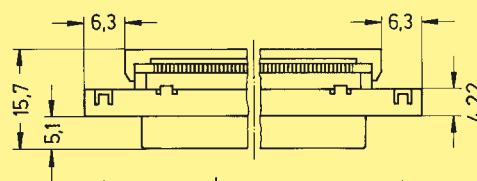
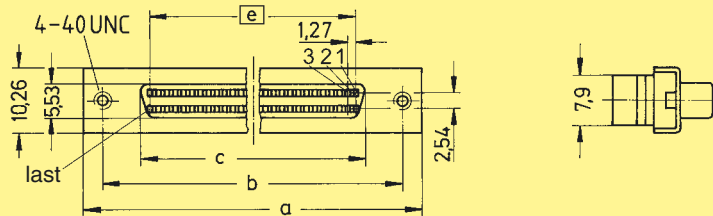

Panel cut out

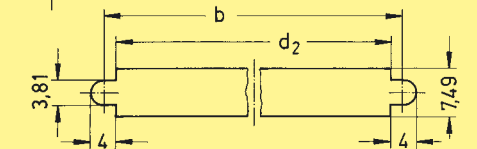

Dimensions in mm

Number of contacts

20–100



Male connectors for IDC discrete wire, straight

Identification	No. of contacts	Part No.
Male connectors with insulation displacement termination for discrete wire AWG 28/30	20	60 03 020 52 . . .
	26	60 03 026 52 . . .
	28	60 03 028 52 . . .
	50	60 03 050 52 . . .
	68	60 03 068 52 . . .
	100	60 03 100 52 . . .
Insulation diameter (mm)	∅ = 0.50–0.65	00
	∅ = 0.65–0.80	10
	∅ = 0.80–0.88	20

Available sizes

	Part No.	∅	20	26	28	50	68	100
Male	60 03 . . . 5200	0.50–0.65	●	●	●	●	●	
	60 03 . . . 5210	0.65–0.80	●			●	●	●
	60 03 . . . 5220	0.80–0.88	●	●	●	●	●	

● = Available sizes

Dimensions

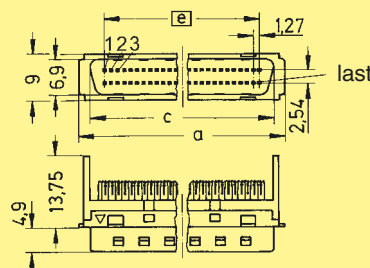

	a	c	d	e
20	21.25	17.00	16.75	11.43
26	25.06	20.81	20.56	15.24
28	26.33	22.08	21.83	16.51
50	40.30	36.05	35.80	30.48
68	51.73	47.48	47.23	41.91
100	72.05	67.80	67.55	62.23

Comb cover (delivered with connectors)

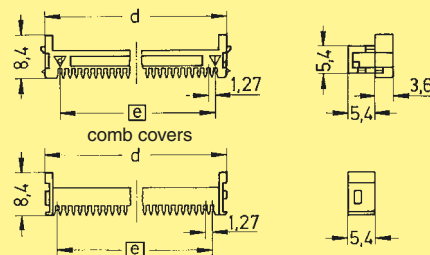

Dimensions in mm

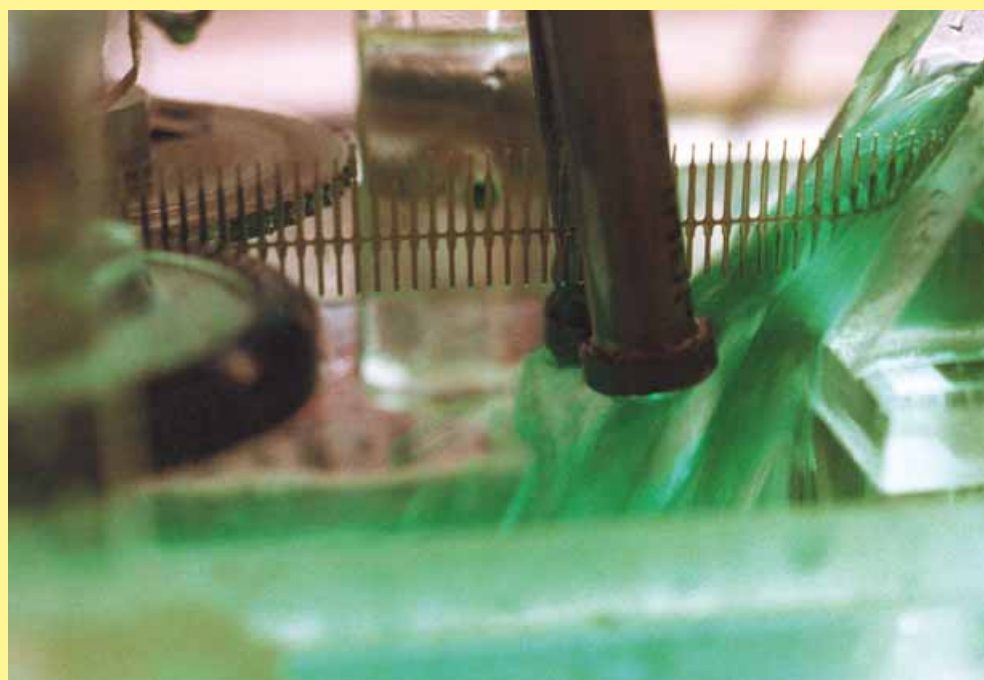

High quality contact surfaces require expertise and latest technological equipment.

Technology at HARTING preserves natural resources thus improving the environment

Number of contacts	20, 26, 28, 36, 50, 68, 80
Pitch	1.27 mm
Working current	1 A
Working voltage	240 V ~
Test voltage $U_{r.m.s.}$	750 V
Contact resistance	$\leq 40 \text{ m}\Omega$
Insulation resistance	$\geq 10^3 \text{ M}\Omega$
Temperature range	-55 °C ... + 105 °C
Terminations	
Solder cup	AWG 24 Insulation max. \varnothing 1 mm
Solder pins	Straight for pcb holes min. \varnothing 0.74 mm Angled 90° for pcb holes min. \varnothing 0.74 mm
Insulation displacement	AWG 28 to AWG 30 max. section: 0.089 mm ² min. section: 0.050 mm ² Insulation \varnothing min. 0.50 mm \varnothing max. 0.65 mm
Materials	
Moulding	Thermoplastic resin glass-fibre filled UL 94-V0
Contacts	Copper alloy
Contact surface	Selectively gold-plated
Metal shell	Die cast zamac or stamped steel, nickel-plated
Hoods	Die cast zamac, nickel-plated Thermoplastic resin nickel-plated, steel insert

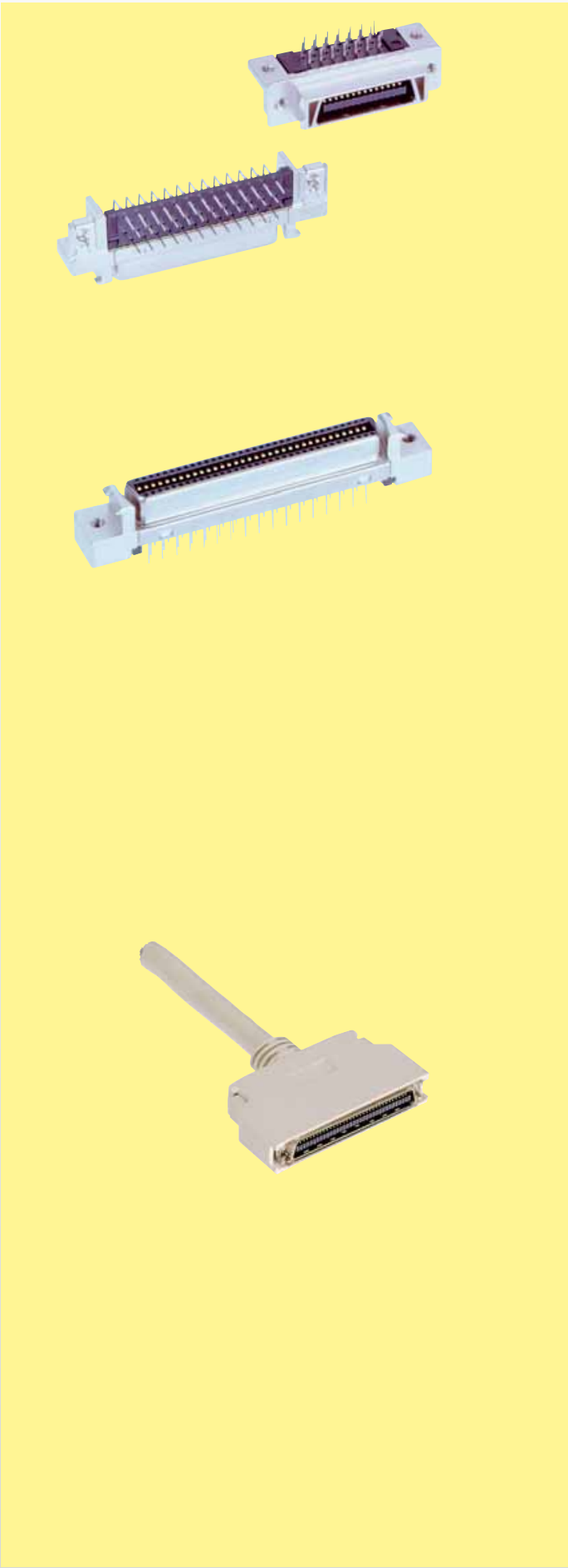

Number of contacts

20–80



Male and female connectors, straight

Identification	No. of contacts	Part No.
Male and female connectors with straight solder pins		Male connector
		Female connector
	20	60 11 020 5102
	26	60 11 026 5102
	36	60 11 036 5102
	50	60 11 050 5102
	68	60 11 068 5102
80	60 11 080 5102	

Dimensions for male connectors

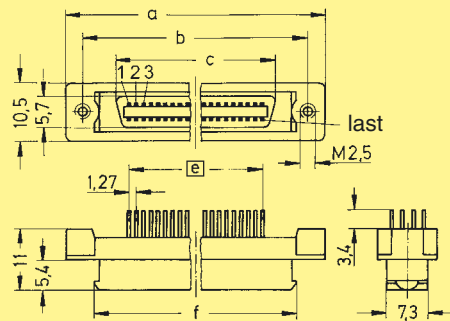

Board drillings

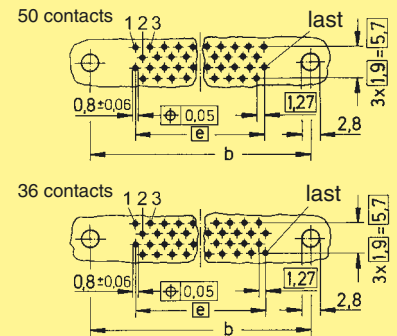

	a	b _{±0.1}	c	e	f	g	h
20	33.35	27.45	16.45	9 x 1.27 = 11.43	23.30	23.70	27.45
26	37.16	31.26	20.26	12 x 1.27 = 15.24	27.11	27.50	31.25
36	43.51	37.61	26.61	17 x 1.27 = 21.59	33.46	33.90	37.60
50	52.40	46.50	35.50	24 x 1.27 = 30.48	42.35	42.80	46.50
68	63.83	57.93	46.93	33 x 1.27 = 41.91	53.78	54.20	57.90
80	71.45	65.55	54.55	39 x 1.27 = 49.53	61.40	61.80	65.55

Dimensions for female connectors

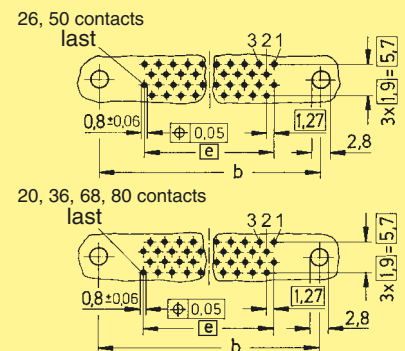
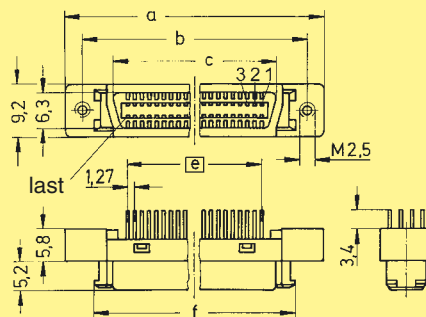

Panel cut out

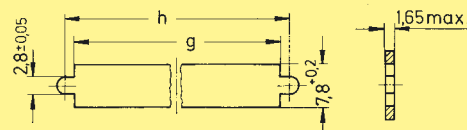

Dimensions in mm

harmik

Number of contacts

20–80

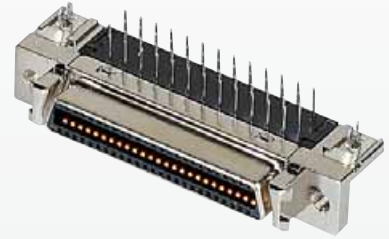

Male and female connectors, angled

Identification	No. of contacts	Part No.	
Male and female connectors with angled solder pins		Male connector	
		Female connector	
	20	60 11 020 5232	60 11 020 51...
	26		60 11 026 51...
	28	60 11 028 5232	
	36	60 11 036 5232	60 11 036 51...
	50	60 11 050 5232	60 11 050 51...
	68	60 11 068 5232	60 11 068 51...
	80	60 11 080 5232	60 11 080 51...
	Without board lock	32	
With board lock	40		

Dimensions for male connectors

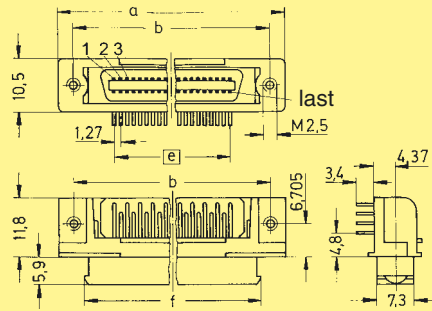

Board drillings

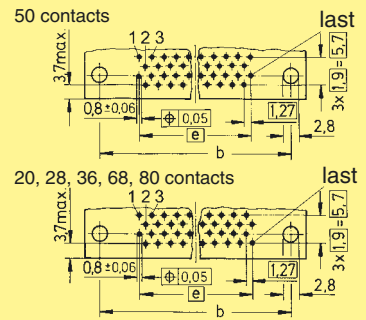

	a	b _{±0.1}	c	e	f	g	h
20	33.40	27.40	16.45	9 x 1.27 = 11.43	23.30	23.70	27.45
26	37.16	31.26	20.26	12 x 1.27 = 15.24	27.11	27.50	31.25
28	38.48	32.48	—	13 x 1.27 = 16.51	28.38	28.80	32.50
36	43.56	37.56	26.61	17 x 1.27 = 21.59	33.46	33.90	37.60
50	52.45	46.45	35.50	24 x 1.27 = 30.48	42.35	42.80	46.50
68	63.88	57.88	46.93	33 x 1.27 = 41.91	53.78	54.20	57.90
80	71.50	65.50	54.55	39 x 1.27 = 49.53	61.40	61.80	65.55

Dimensions for female connectors

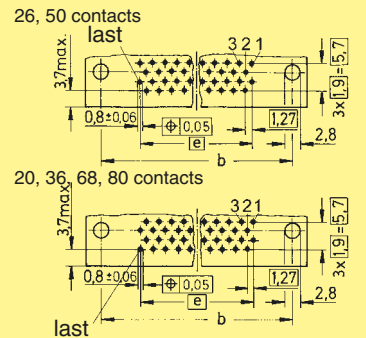
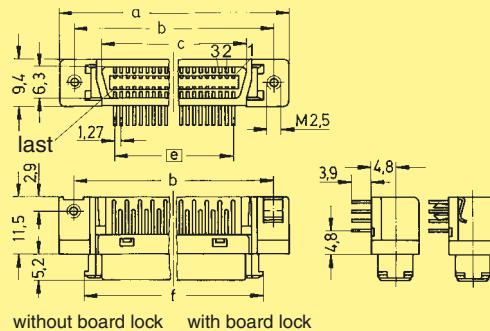

Panel cut out

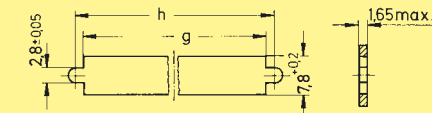

Dimensions in mm

Number of contacts

20–80



Male and female connectors for IDC discrete wire, straight

Identification	No. of contacts	Part No.	
Male and female connectors with insulation displacement termination for discrete wire AWG 28/30 Insulation diameter (mm) $\varnothing = 0.50-0.65$		Male connector	Female connector
	20	60 13 020 5200	60 13 020 5100
	26	60 13 026 5200	
	28		60 13 028 5100
	36	60 13 036 5200	60 13 036 5100
	50	60 13 050 5200	60 13 050 5100
	68	60 13 068 5200	60 13 068 5100
	80	60 13 080 5200	60 13 080 5100

Dimensions for male connectors

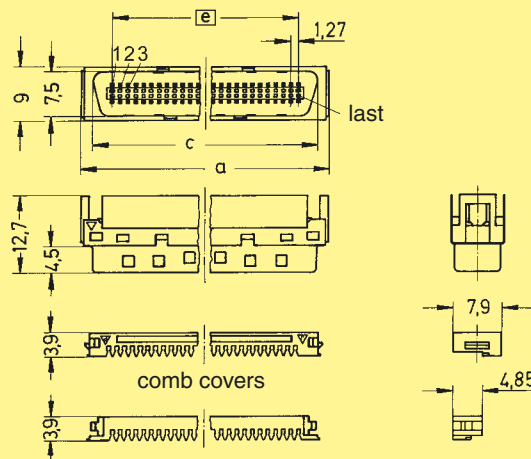

	a	c	e
20	21.24	17.55	11.43
26	25.05	21.36	15.24
36	31.40	27.71	21.59
50	40.29	36.60	30.48
68	51.72	48.03	41.91
80	59.34	55.65	49.53

Dimensions for female connectors

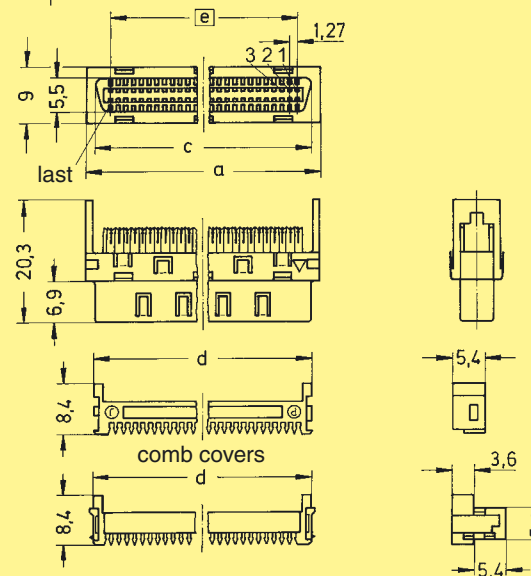

	a	c	d	e
20	19.25	16.25	16.75	11.43
28	24.33	21.33	21.83	16.51
36	29.41	26.41	26.91	21.59
50	38.30	35.30	35.80	30.48
68	49.73	46.73	47.23	41.91
80	57.35	54.35	54.85	49.53

Dimensions in mm

Number of contacts

20–50



Female connectors, straight

Identification	No. of contacts	Part No.
Female connectors with solder cup AWG 24	20	60 13 020 5180
	28	60 13 028 5180
	36	60 13 036 5180
	50	60 13 050 5180

Dimensions

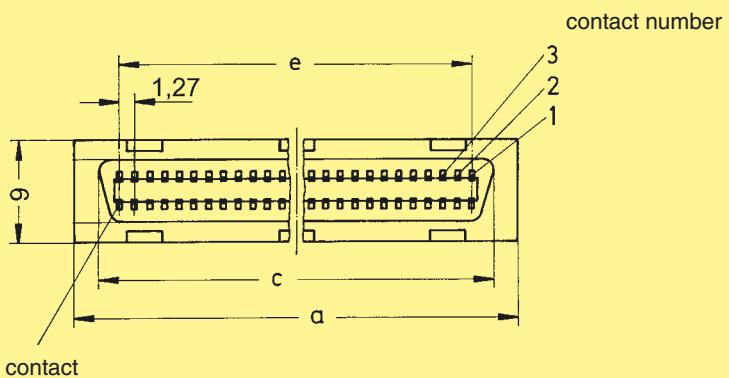
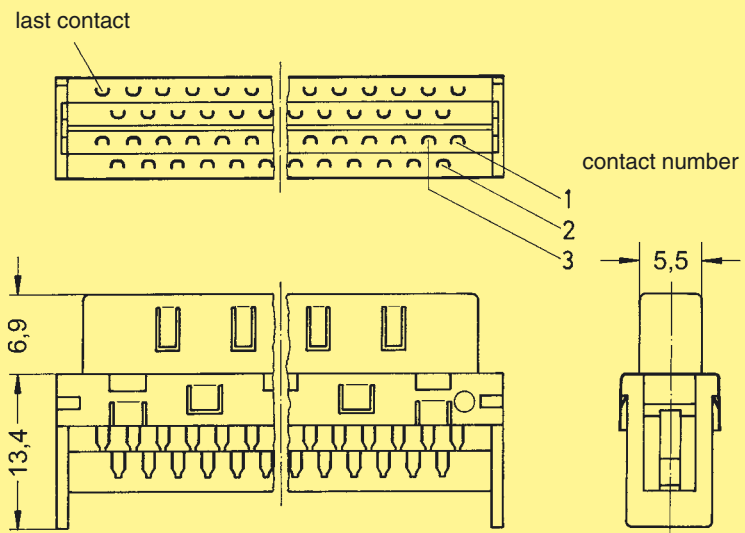

	a	c	e
20	19.25	16.25	11.43
28	24.33	21.33	16.51
36	29.41	26.41	21.59
50	38.30	35.30	30.48

Dimensions in mm

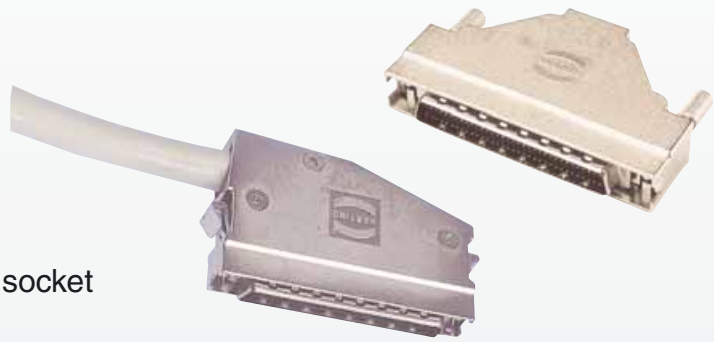

Metal hoods for male and female pin and socket and for female bellows connector

Identification	No. of contacts	Part No.	Drawing	Dimensions in mm																													
Metal hood Cable side entry	20	60 03 020 0555	<table border="1"> <thead> <tr> <th rowspan="2"></th> <th colspan="2">Shell dimensions</th> <th colspan="2">Cable dimensions</th> </tr> <tr> <th>a</th> <th>b</th> <th>min.</th> <th>max.</th> </tr> </thead> <tbody> <tr> <td>20</td> <td>29.0</td> <td>32.9</td> <td>6.2</td> <td>8.0</td> </tr> <tr> <td>26</td> <td>32.8</td> <td>32.9</td> <td>6.5</td> <td>8.5</td> </tr> <tr> <td>50</td> <td>48.0</td> <td>35.6</td> <td>8.3</td> <td>10.3</td> </tr> <tr> <td>68</td> <td>59.4</td> <td>35.6</td> <td>8.7</td> <td>10.7</td> </tr> </tbody> </table>		Shell dimensions		Cable dimensions		a	b	min.	max.	20	29.0	32.9	6.2	8.0	26	32.8	32.9	6.5	8.5	50	48.0	35.6	8.3	10.3	68	59.4	35.6	8.7	10.7	
		Shell dimensions			Cable dimensions																												
		a		b	min.	max.																											
	20	29.0		32.9	6.2	8.0																											
26	32.8	32.9	6.5	8.5																													
50	48.0	35.6	8.3	10.3																													
68	59.4	35.6	8.7	10.7																													
26	60 03 026 0555																																
50	60 03 050 0555																																
68	60 03 068 0555																																
Large cable side entry	68	60 03 068 0655	<table border="1"> <thead> <tr> <th rowspan="2"></th> <th colspan="2">Shell dimensions</th> <th colspan="2">Cable dimensions</th> </tr> <tr> <th>a</th> <th>b</th> <th>min.</th> <th>max.</th> </tr> </thead> <tbody> <tr> <td>68</td> <td>59.4</td> <td>35.6</td> <td>10.0</td> <td>12.0</td> </tr> </tbody> </table>		Shell dimensions		Cable dimensions		a	b	min.	max.	68	59.4	35.6	10.0	12.0																
	Shell dimensions		Cable dimensions																														
	a	b	min.	max.																													
68	59.4	35.6	10.0	12.0																													
Metal hood Top cable entry	68	60 03 068 01...	<table border="1"> <thead> <tr> <th rowspan="2"></th> <th colspan="2">Shell dimensions</th> <th colspan="2">Cable dimensions</th> </tr> <tr> <th>a</th> <th>b</th> <th>min.</th> <th>max.</th> </tr> </thead> <tbody> <tr> <td>68</td> <td>65.1</td> <td>38.2</td> <td>8.7</td> <td>10.7</td> </tr> </tbody> </table>		Shell dimensions		Cable dimensions		a	b	min.	max.	68	65.1	38.2	8.7	10.7																
						Shell dimensions		Cable dimensions																									
a	b	min.	max.																														
68	65.1	38.2	8.7	10.7																													
With male jack screw 2-56 UNC With male jack screw 4-40 UNC	45 47																																



Plastic hood with internal metal screen

Identification No. of contacts Part No. Drawing Dimensions in mm

Plastic hood with internal screen
for male and female pin and socket range and
for female bellows range

50	60 03 050 01 ...
68	60 03 068 01 ...
100	60 03 100 01 ...

With male jack screw 2-56 UNC	43
With male jack screw 4-40 UNC	46

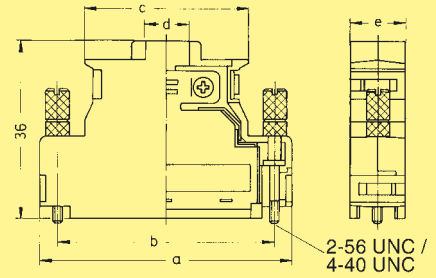

	a	b	c	d	e
50	54.00	46.48	35.00	10.50	12.00
68	65.41	57.91	38.40	14.00	12.00
100	85.73	78.23	42.00	13.00	12.00

Plastic hood with internal screen
for male bellows range

20	60 13 020 0153
26	60 13 026 0153
36	60 13 036 0153
50	60 13 050 0153
68	60 13 068 0153
80	60 13 080 0153

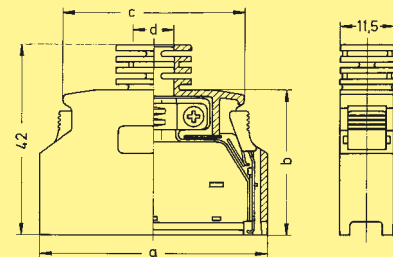

	a	b	c	d
20	29.65	34.50	19.95	6.80
26	33.46	38.31	23.76	7.10
36	39.81	32.00	30.11	8.20
50	48.70	32.00	39.00	8.70
68	60.13	32.00	50.43	9.10
80	67.75	32.00	58.05	9.70



harmik

Female screw lock

Identification Part No. Drawing Dimensions in mm

Screw lock

Thread: M 2.5 / 2-56 UNC
Height: 2.9 mm

60 01 000 9013

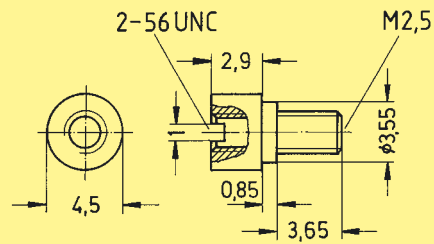

Screw lock

Thread: 4-40 UNC / 4-40 UNC
Height: 3.99 mm

60 01 000 9018

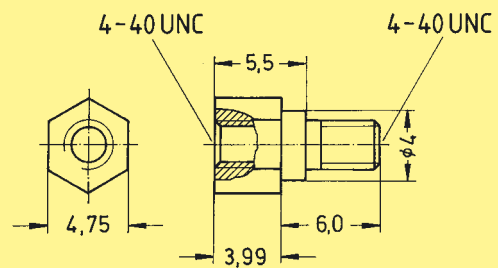

Screw lock

Thread: 4-40 UNC / 2-56 UNC
Height: 3.99 mm

60 01 000 9019

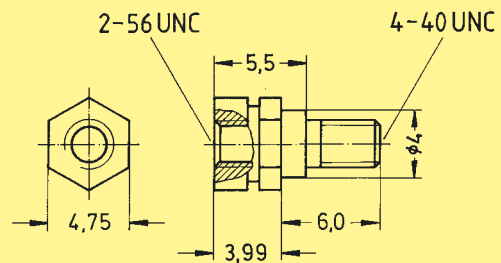

Screw lock

Thread: 4-40 UNC / 2-56 UNC
Height: 5.5 mm

60 01 000 9020

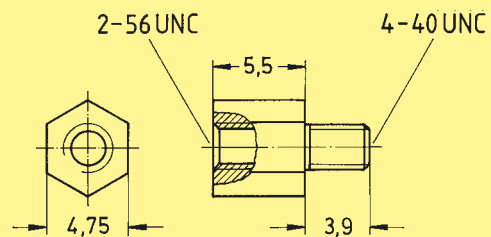

Screw lock

Thread: 4-40 UNC / 4-40 UNC
Height: 5.5 mm

60 01 000 9021

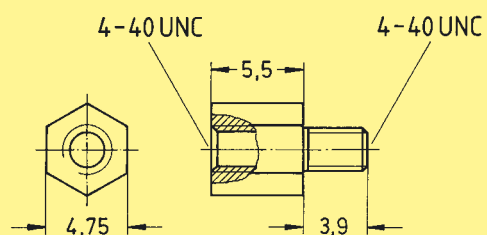

for economical and reliable connections

A comprehensive range of high density intra cabinet connectors based on two mating design concepts:

- Blade and fork contact in the Pin/Socket range.
- Leaf contact in the Bellows range.

Available in a various number of contacts according to the following international standards and applications:

- Small Computer System Interface
SCSI-2
SCSI-2 wide
SCSI-3

- S Bus
IEEE 1496

- Internal Bus extension through
“Daisy chain” inter-linking via
0.635 mm pitch flat cable.
The 4-point design of the IDC
contact provides accurate and
reliable termination even with
teflon cable.

UL recognised

For customer specific applications we can design and manufacture solutions to match your requirement.

Sales department
HARTING components



Certified according to EN ISO 9001
in design/development, production,
installation and servicing

Pitch	1.27 mm
Working current	
pcb connector	1 A
Flat cable connector	0,5 A
Working voltage	
pcb connector	240 V ~
Flat cable connector	100 V ~
Test voltage U_{r.m.s.}	
pcb connector	750 V
Flat cable connector	500 V
Contact resistance	≤ 25 mΩ
Insulation resistance	≥ 10 ³ MΩ
Temperature range	-55 °C ... + 105 °C
Terminations	
Solder pins	Straight for pcb holes min. Ø 0.74 mm Angled 90° for pcb holes min. Ø 0.74 mm
Insulation displacement	Flat cable AWG 30 pitch 0.635 mm
Materials	
Moulding	Thermoplastic resin glass-fibre filled UL 94-V0
Contacts	
pcb connector	Copper alloy
Flat cable connector	Beryllium copper
Contact surface	Selectively gold-plated

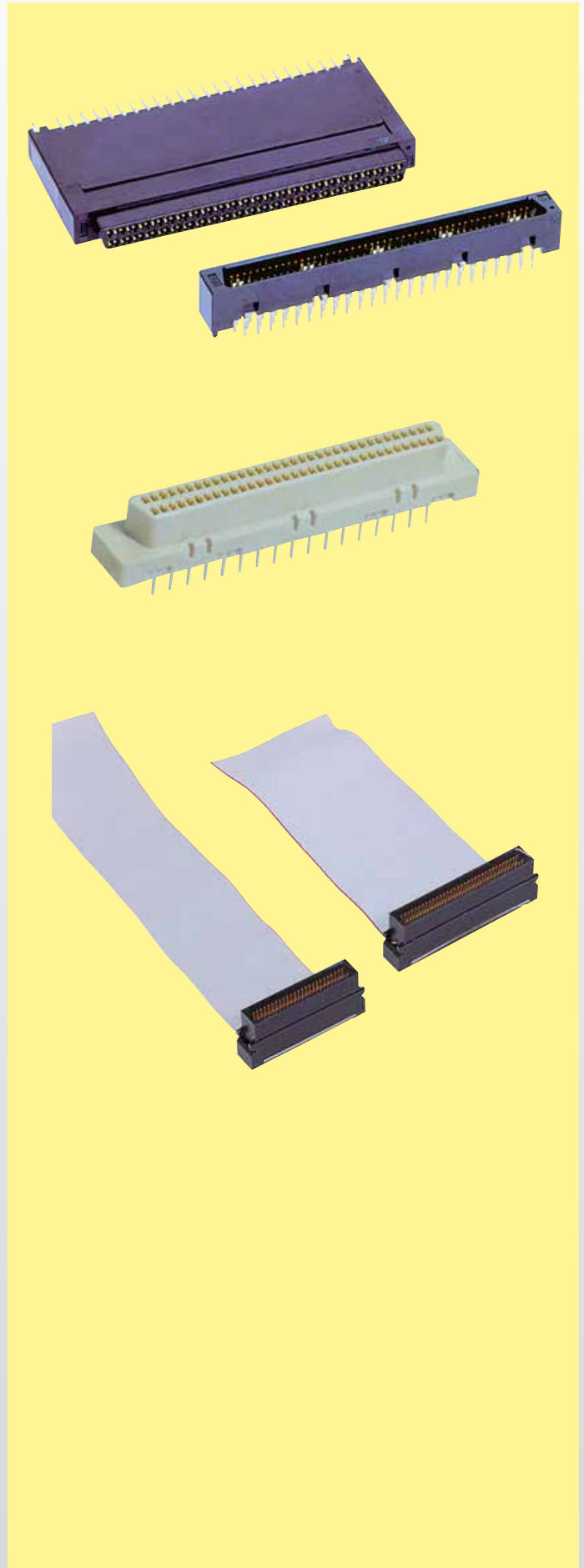

Number of contacts

68

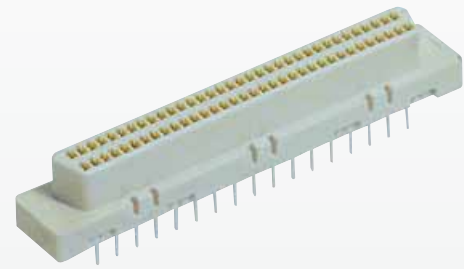

Female connectors, straight

har-mik

Identification	No. of contacts	Part No.
Female connector with straight solder pins	68	60 05 068 5100

Dimensions

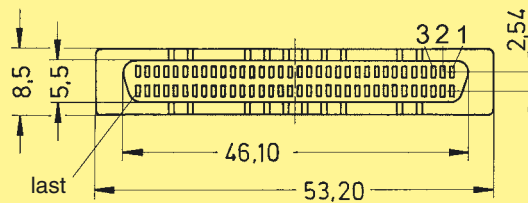
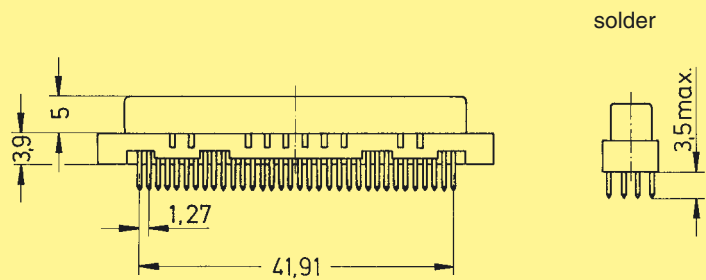

Board drillings
(Components side)

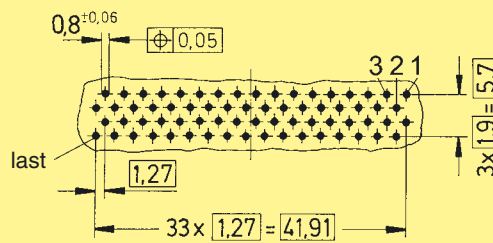

Number of contacts

96



Male connector, straight

Identification	No. of contacts	Part No.
Male connector straight with natural retention solder pins	96	60 05 096 5218

Dimensions

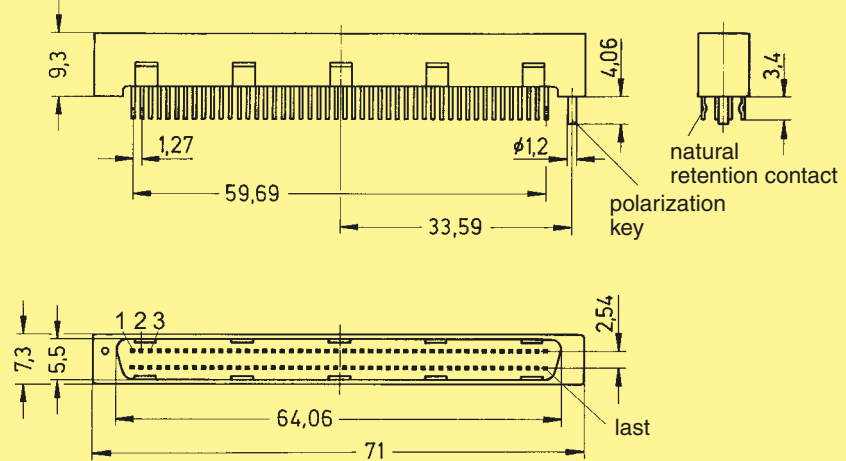

Board drillings
(Components side)

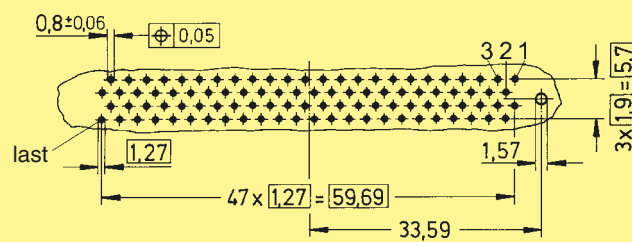

Dimensions in mm

Number of contacts

96

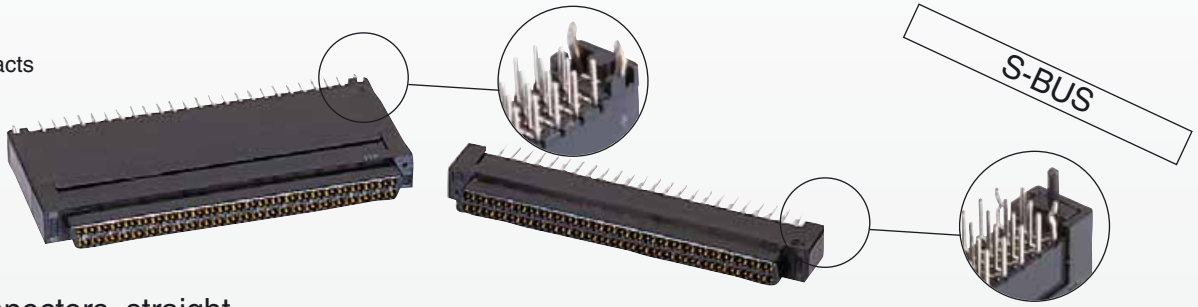

Female connectors, straight

Identification	No. of contacts	Part No.	
Female connectors with straight solder pins	96	34.80 mm high version	14.45 mm high version
		60 05 096 5121	60 05 096 5118

Dimensions
34.80 mm high version with board lock

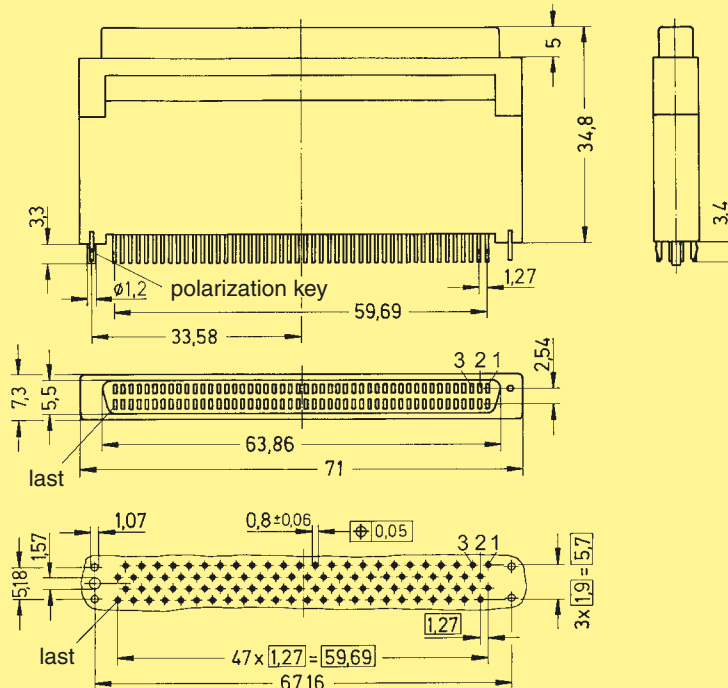

Dimensions in mm

Board drillings
(Components side)

Dimensions
14.45 mm high version with natural retention pins

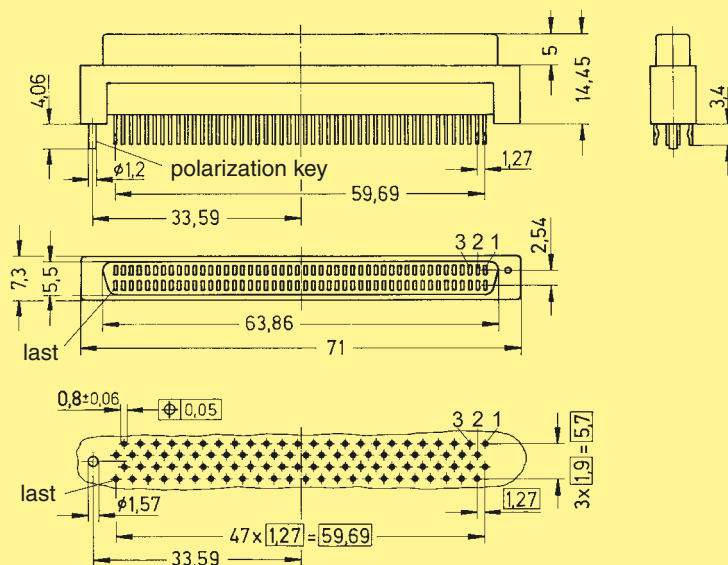

Dimensions in mm

Board drillings
(Components side)

har-mik

Number of contacts

68

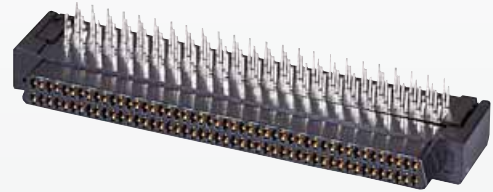

Female connector, angled

Identification	No. of contacts	Part No.
Female connector angled with natural retention solder pins	68	60 05 068 5143

Dimensions

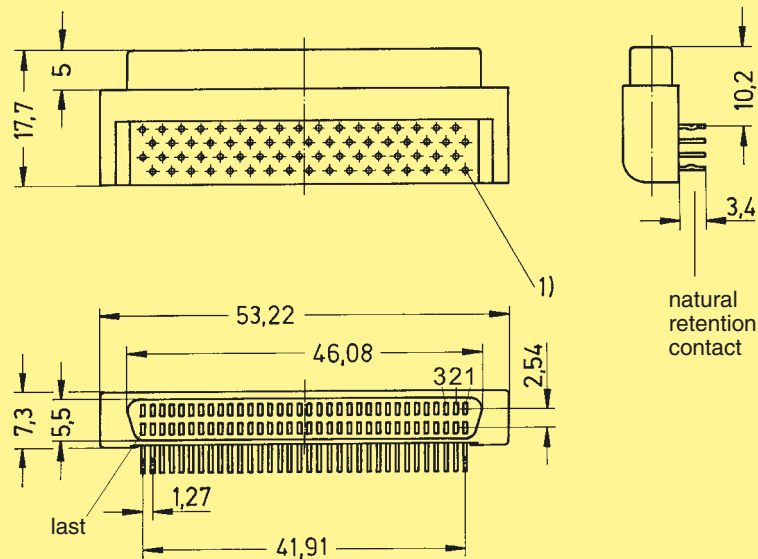

Board drillings
(Components side)

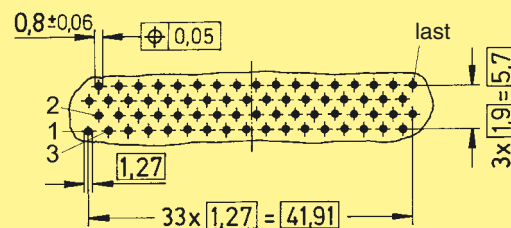

Dimensions in mm

Number of contacts

50–68



Male connectors for IDC flat cable, straight

Identification	No. of contacts	Part No.
Male connectors with insulation displacement termination for IDC flat cable pitch 0.635 mm AWG 30 Strain relief order separately		Male connector
		Strain relief
	50	60 06 050 5440
	68	60 06 068 5440

Dimensions

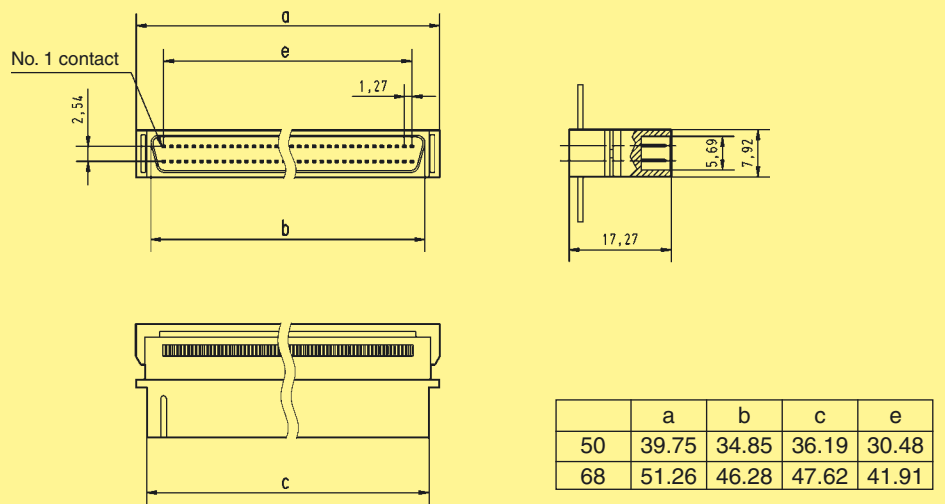

Strain relief

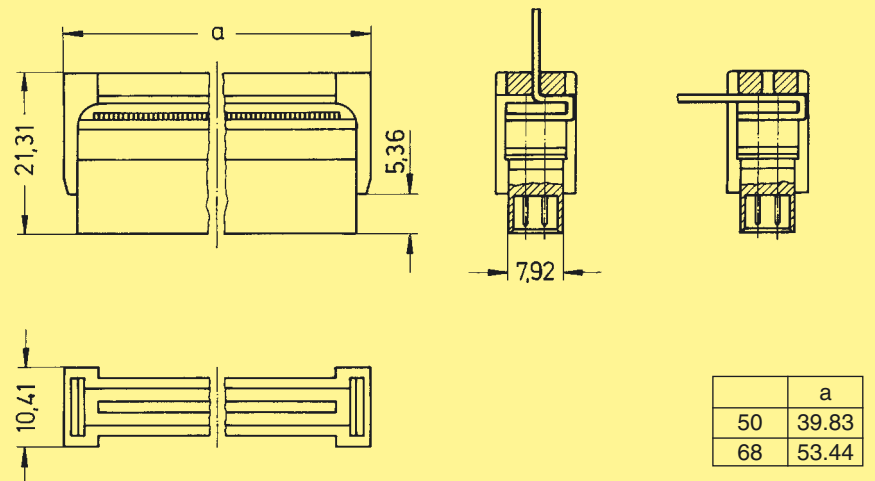

Dimensions in mm

