

# InGaAs PIN photodiode G9801 series

Receptacle type, 1.3/1.55  $\mu\text{m}$ , 2 GHz



G9801 series are high-speed receivers specifically developed for 1.3/1.55  $\mu\text{m}$  band optical fiber communications. These devices incorporate a high-speed, high-sensitivity InGaAs PIN photodiode integrated in a receptacle module. Packages are available with various connectors and mounting styles.

## Features

- High-speed response: 2 GHz Typ.
- Low dark current: 20 pA Typ.
- High sensitivity: 0.9 A/W Typ. ( $\lambda=1.31 \mu\text{m}$ )
- Low terminal capacitance: 1 pF Typ.

## Applications

- Optical fiber communications

### ■ Absolute maximum ratings (Ta=25 °C)

Parameter	Symbol	Value	Unit
Reverse voltage	V <sub>R</sub> Max.	20	V
Operating temperature	T <sub>opr</sub>	-20 to +70	°C
Storage temperature	T <sub>stg</sub>	-40 to +85	°C

### ■ Electrical and optical characteristics (Ta=25 °C)

Parameter	Symbol	Condition	Min.	Typ.	Max.	Unit
Spectral response range	$\lambda$		-	0.9 to 1.7	-	$\mu\text{m}$
Peak sensitivity wavelength	$\lambda_p$		-	1.55	-	$\mu\text{m}$
Photo sensitivity	S *1	$\lambda=1.3 \mu\text{m}$	0.75	0.9	-	A/W
		$\lambda=1.55 \mu\text{m}$	0.8	0.95	-	A/W
Dark current	I <sub>D</sub>	V <sub>R</sub> =5 V	-	0.02	0.4	nA
Cut-off frequency	f <sub>c</sub>	V <sub>R</sub> =5 V, R <sub>L</sub> =50 $\Omega$ $\lambda=1.3 \mu\text{m}$ , -3 dB	-	2	-	GHz
Terminal capacitance	C <sub>t</sub>	V <sub>R</sub> =5 V, f=1 MHz	-	1	1.5	pF
Noise equivalent power	NEP	V <sub>R</sub> =5 V, $\lambda=1.55 \mu\text{m}$	-	$3 \times 10^{-15}$		W/Hz <sup>1/2</sup>

\*1: Using a single mode optical fiber with a master plug.

### ■ Package lineup

Parameter	G9801		
	-21	-22	-32
Mounting style	Board		Panel
Connector	SC	FC	FC
Dimensional outline	①	②	③

■ Dimensional outlines (unit: mm, tolerance unless otherwise noted:  $\pm 0.2$ )

① G9801-21

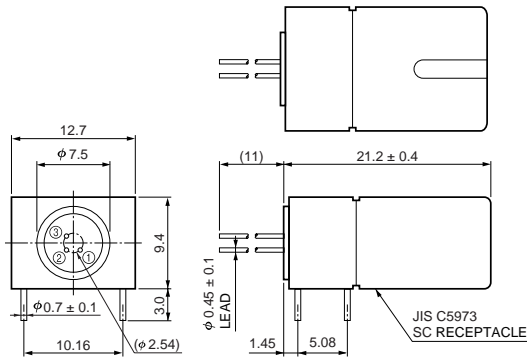

KIRDA0078EB

② G9801-22

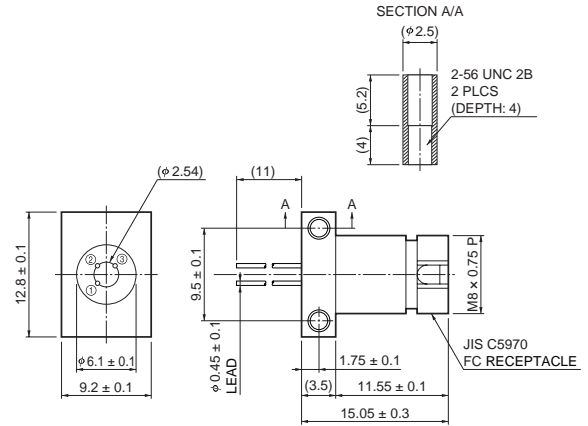

KIRDA0079EB

③ G9801-32

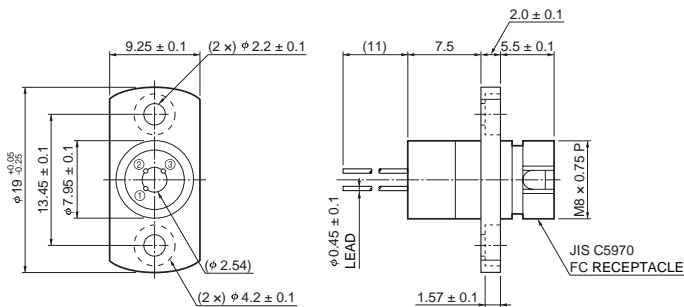

KIRDA0080EB

■ Pin connection

①	Anode
②	Cathode
③	Case

**HAMAMATSU**

Information furnished by HAMAMATSU is believed to be reliable. However, no responsibility is assumed for possible inaccuracies or omissions. Specifications are subject to change without notice. No patent rights are granted to any of the circuits described herein. ©2005 Hamamatsu Photonics K.K.

HAMAMATSU PHOTONICS K.K., Solid State Division

1126-1 Ichino-cho, Hamamatsu City, 435-8558 Japan, Telephone: (81) 053-434-3311, Fax: (81) 053-434-5184, <http://www.hamamatsu.com>

U.S.A.: Hamamatsu Corporation: 360 Foothill Road, P.O.Box 6910, Bridgewater, N.J. 08807-0910, U.S.A., Telephone: (1) 908-231-0960, Fax: (1) 908-231-1218

Germany: Hamamatsu Photonics Deutschland GmbH: Arzbergerstr. 10, D-82211 Herrsching am Ammersee, Germany, Telephone: (49) 08152-3750, Fax: (49) 08152-2658

France: Hamamatsu Photonics France S.A.R.L.: 8, Rue du Saule Trapu, Parc du Moulin de Massy, 91882 Massy Cedex, France, Telephone: 33-(1) 69 53 71 00, Fax: 33-(1) 69 53 71 10

United Kingdom: Hamamatsu Photonics UK Limited: 2 Howard Court, 10 Tewin Road, Welwyn Garden City, Hertfordshire AL7 1BW, United Kingdom, Telephone: (44) 1707-294888, Fax: (44) 1707-325777

North Europe: Hamamatsu Photonics Norden AB: Smidesvägen 12, SE-171 41 Solna, Sweden, Telephone: (46) 8-509-031-00, Fax: (46) 8-509-031-01

Italy: Hamamatsu Photonics Italia S.R.L.: Strada della Moia, 1/E, 20020 Arese, (Milano), Italy, Telephone: (39) 02-935-81-733, Fax: (39) 02-935-81-741