

SEALED POLYCARBONATE AND ABS ENCLOSURES WITH MOUNTING FLANGE



PRODUCT INFORMATION

- The lid and base incorporate a tongue and groove sealing system with a EPDM gasket.
- Wall mounting holes and lid fixing screws are outside the sealing area thus preventing the ingress of moisture and dust.
- Designed to IP65 of IEC 529 (Dust and Hoseproof).
- Bosses on internal base allow fixing of PCB's horizontally or connection of terminals with M3X4mm self-tapping screws.
- Internal guide slots for mounting PCB assemblies vertically.
- Available with clear or light grey lids.



G256MF



G258CMF



G366MF

Content

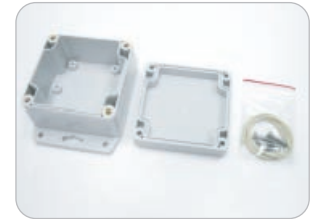

G256MF

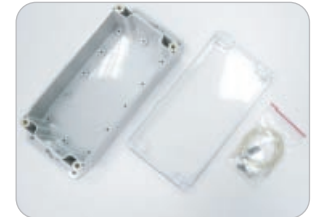

G258CMF



G366MF

PC
(G2XXMF)
(G2XXCMF)

- Material: Polycarbonate (UL94-HB)
- Moulded in: Light Grey.
- Operating temperature: -40°C to 120°C.
- Clear lid is available on request.
- Mounting flange is designed on the bottom of the base, so the base can be mounted with pan head type of screws on the wall easily.
**Detailed screw size please refer the product drawing.

ABS
(G3XXMF)

- Material: High Impact ABS (UL94-HB)
- Moulded in: Dark Grey.
- Operating temperature: -20°C to 80°C
- Mounting flange is designed on the bottom of the base, so the base can be mounted with pan head type of screws on the wall easily.
**Detailed screw size please refer the product drawing.

MATERIAL: POLYCARBONATE					
ITEM No.	COLOR		ITEM No.	COLOR	
	LID	BASE		LID	BASE
G201MF	Light Grey		G201CMF	Clear	Light Grey
G203MF	Light Grey		G203CMF	Clear	Light Grey
G205MF	Light Grey		G205CMF	Clear	Light Grey
G212MF	Light Grey		G212CMF	Clear	Light Grey
G221MF	Light Grey		G221CMF	Clear	Light Grey
G214MF	Light Grey		G214CMF	Clear	Light Grey
G223MF	Light Grey		G223CMF	Clear	Light Grey
G218MF	Light Grey		G218CMF	Clear	Light Grey
G232MF	Light Grey		G232CMF	Clear	Light Grey
G200MF	Light Grey		G200CMF	Clear	Light Grey
G250MF	Light Grey		G250CMF	Clear	Light Grey
G256MF	Light Grey		G256CMF	Clear	Light Grey
G258MF	Light Grey		G258CMF	Clear	Light Grey
G265MF	Light Grey		G265CMF	Clear	Light Grey
G278MF	Light Grey		G278CMF	Clear	Light Grey
G279MF	Light Grey		G279CMF	Clear	Light Grey

MATERIAL: ABS			
ITEM No.	COLOR		EXTERNAL DIMENSION(mm)
	LID	BASE	
G302MF	Dark Grey		64 x 58 x 35
G304MF	Dark Grey		115 x 65 x 40
G308MF	Dark Grey		115 x 65 x 55
G311MF	Dark Grey		115 x 90 x 55
G331MF	Dark Grey		115 x 90 x 80
G313MF	Dark Grey		171 x 121 x 55
G340MF	Dark Grey		171 x 121 x 80
G317MF	Dark Grey		222 x 146 x 55
G353MF	Dark Grey		222 x 146 x 75
G300MF	Dark Grey		90 x 35 x 35
G362MF	Dark Grey		52 x 50 x 35
G366MF	Dark Grey		82 x 80 x 55
G368MF	Dark Grey		160 x 80 x 55
G369MF	Dark Grey		160 x 80 x 85
G386MF	Dark Grey		120 x 120 x 60
G387MF	Dark Grey		120 x 120 x 90

▶ Lid fixing screw are M4 stainless steel (non-magnetic) into threaded brass inserts.

G200MF / G300MF

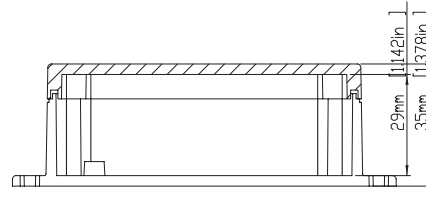
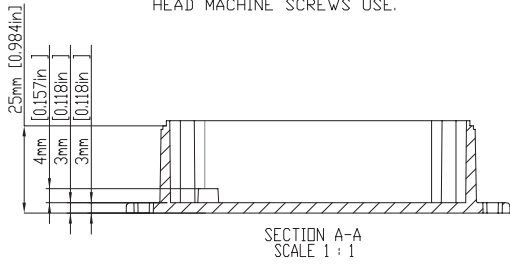
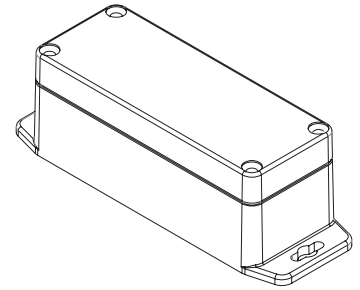
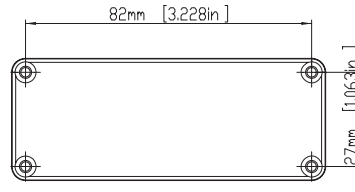
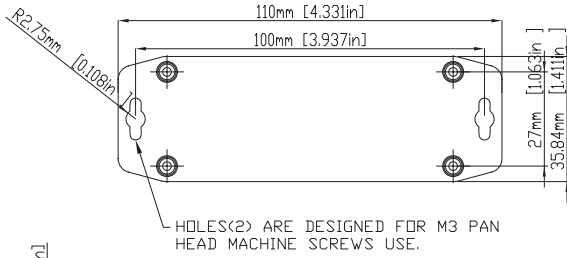
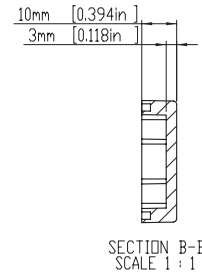
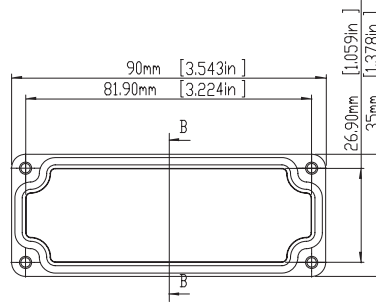
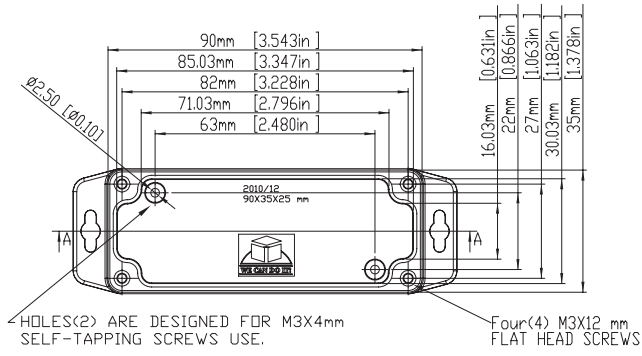

According to ISO 2768-m	
Measuring DIM=L	Tolerances
0.5<L<=3.0mm	±0.1mm
3.0<L<=6.0 mm	±0.1mm
6.0<L<=30.0 mm	±0.2mm
30.0<L<=120.0 mm	±0.3mm
120.0<L<=400.0 mm	±0.5mm
400.0<L<=1000.0 mm	±0.8mm

G201MF / G302MF

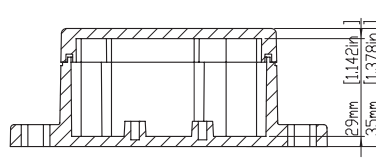
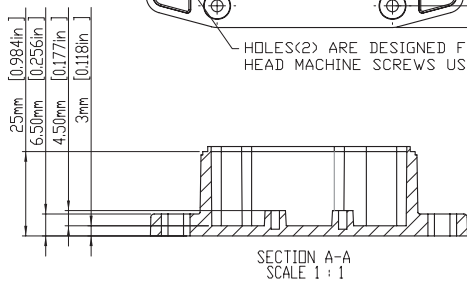
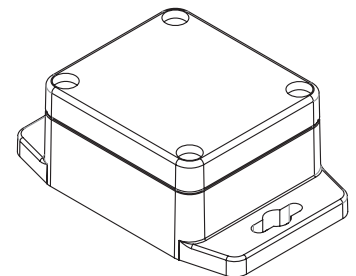
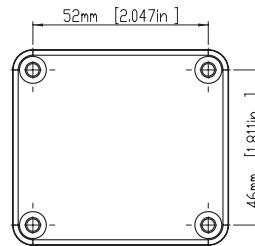
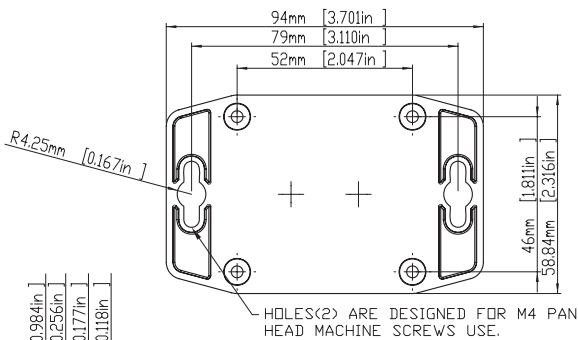
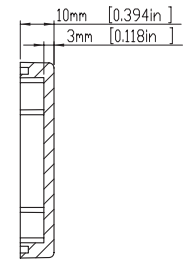
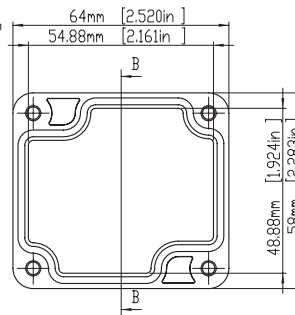
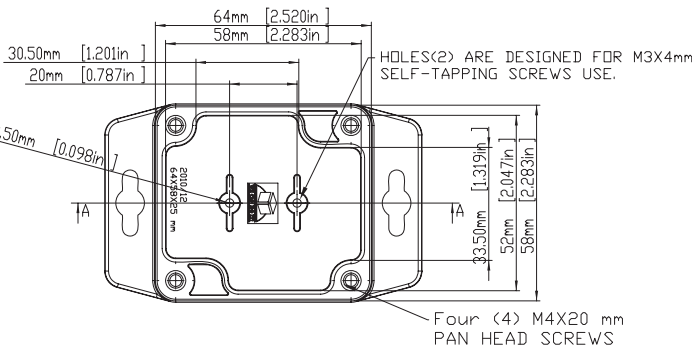

According to ISO 2768-m	
Measuring DIM=L	Tolerances
0.5<L<=3.0mm	±0.1mm
3.0<L<=6.0 mm	±0.1mm
6.0<L<=30.0 mm	±0.2mm
30.0<L<=120.0 mm	±0.3mm
120.0<L<=400.0 mm	±0.5mm
400.0<L<=1000.0 mm	±0.8mm

G203MF / G304MF

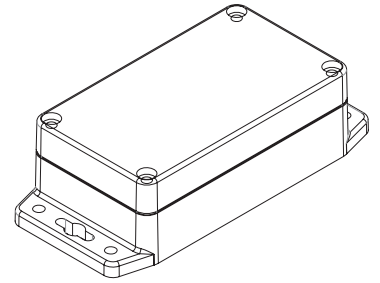
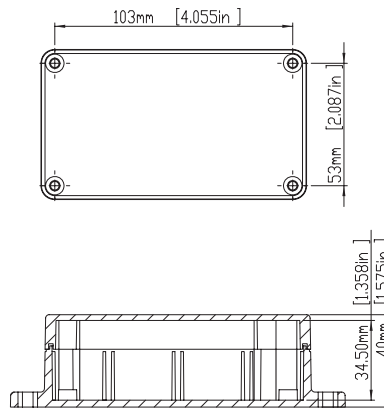
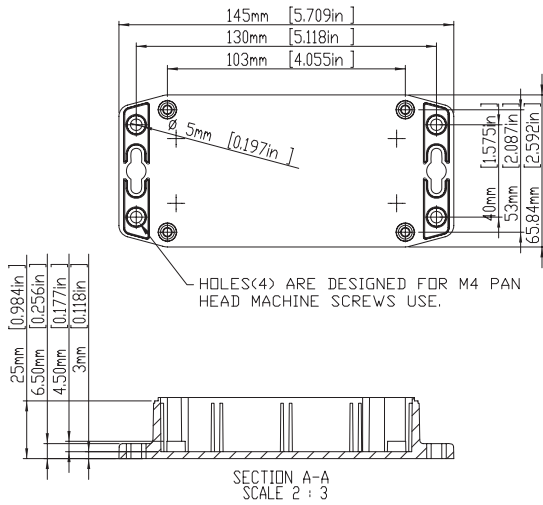
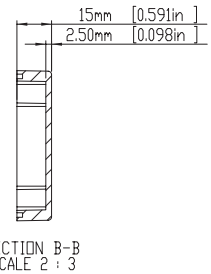
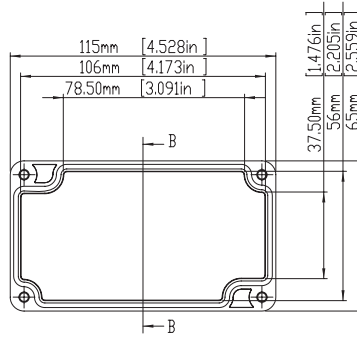
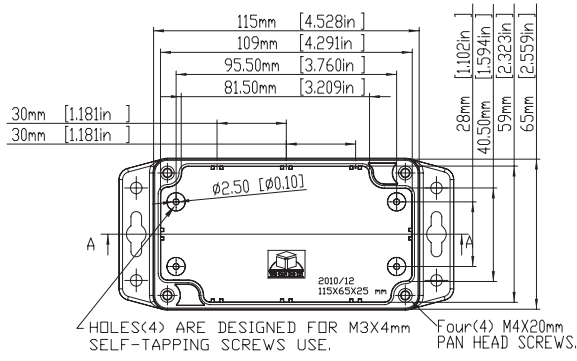

According to ISO 2768-m	
Measuring DIM=L	Tolerances
0.5<L<=3.0mm	±0.1mm
3.0<L<=6.0 mm	±0.1mm
6.0<L<=30.0 mm	±0.2mm
30.0<L<=120.0 mm	±0.3mm
120.0<L<=400.0 mm	±0.5mm
400.0<L<=1000.0 mm	±0.8mm

G205MF / G308MF

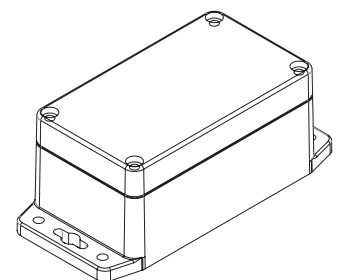
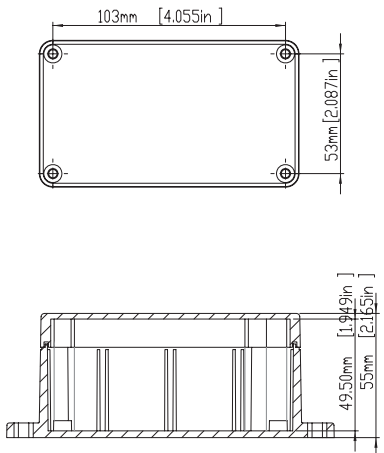
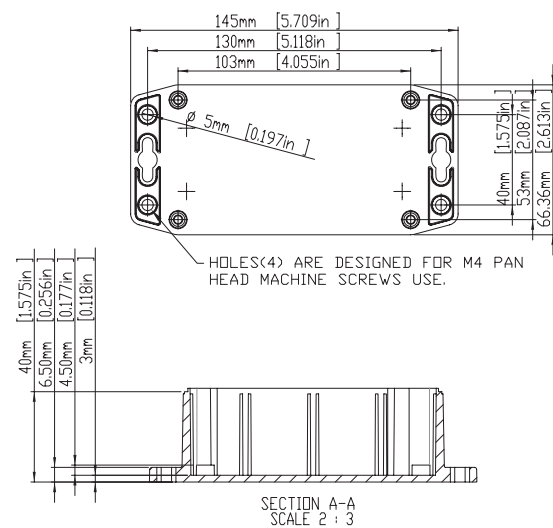
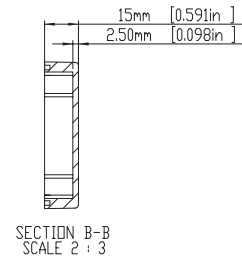
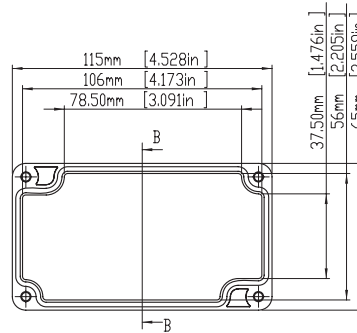
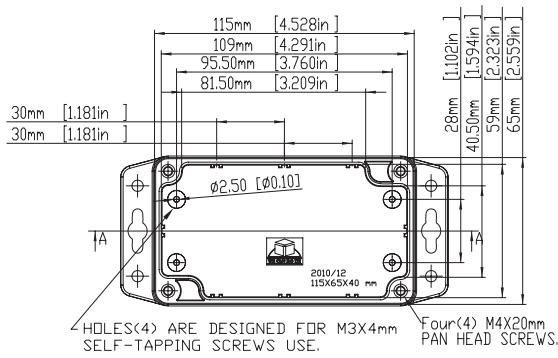

According to ISO 2768-m	
Measuring DIM=L	Tolerances
0.5<L<=3.0mm	±0.1mm
3.0<L<=6.0 mm	±0.1mm
6.0<L<=30.0 mm	±0.2mm
30.0<L<=120.0 mm	±0.3mm
120.0<L<=400.0 mm	±0.5mm
400.0<L<=1000.0 mm	±0.8mm

G212MF / G311MF

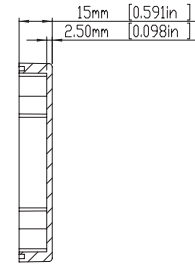
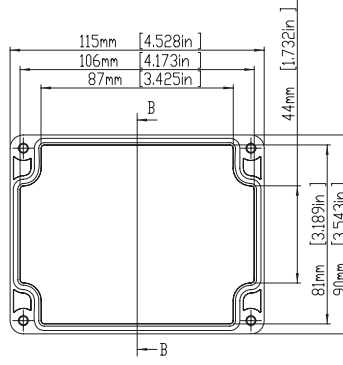
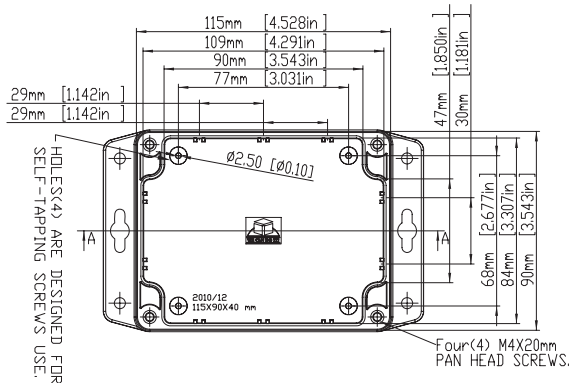

SECTION B-B
SCALE 2 : 3

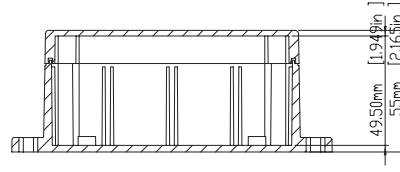
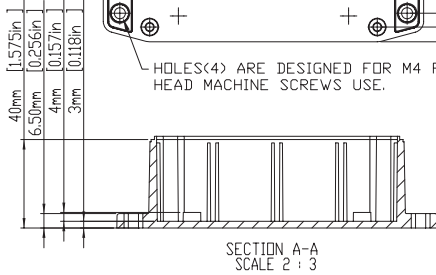
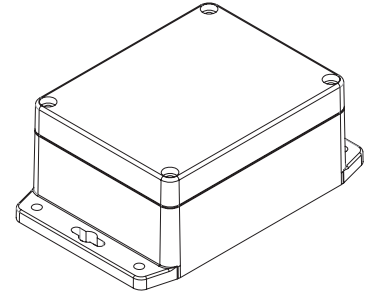
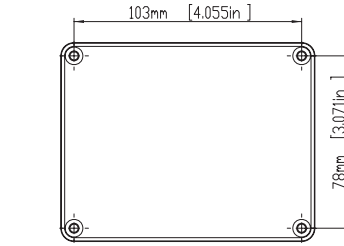
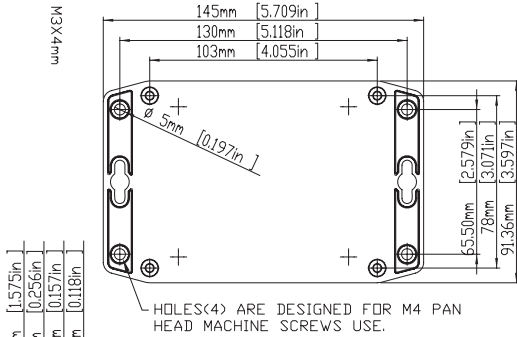

According to ISO 2768-m	
Measuring DIM=L	Tolerances
0.5<L<=3.0mm	±0.1mm
3.0<L<=6.0 mm	±0.1mm
6.0<L<=30.0 mm	±0.2mm
30.0<L<=120.0 mm	±0.3mm
120.0<L<=400.0 mm	±0.5mm
400.0<L<=1000.0 mm	±0.8mm

G214MF / G313MF

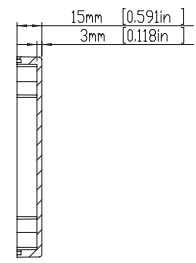
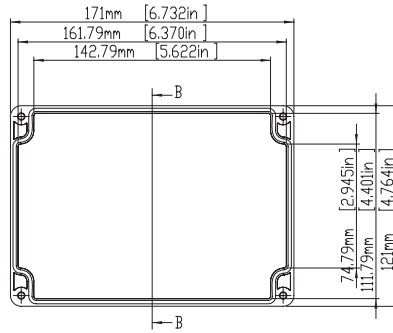
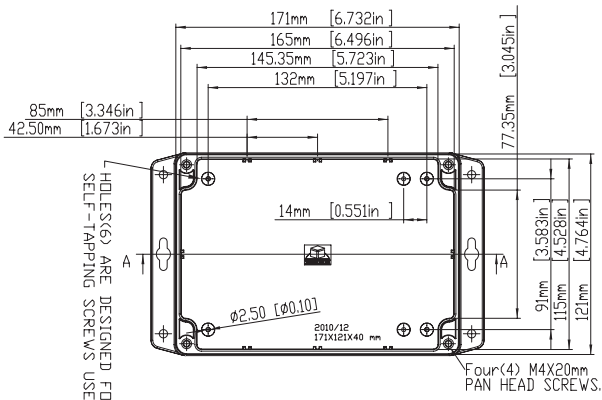

SECTION B-B

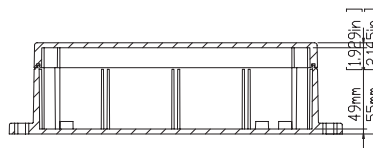
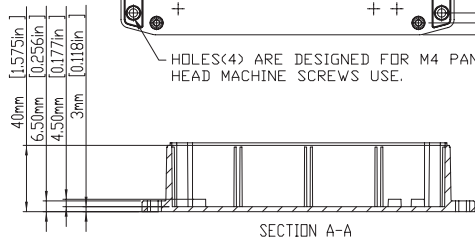
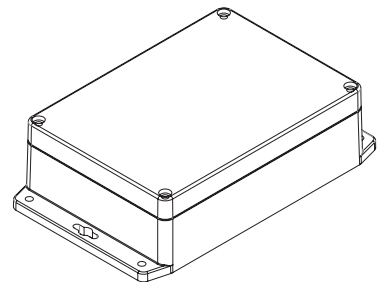
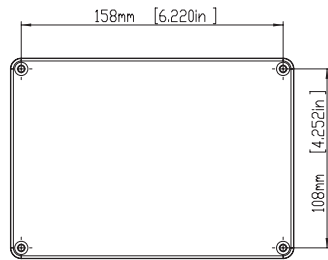
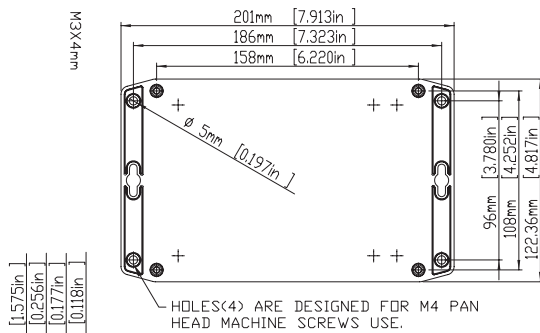

According to ISO 2768-m	
Measuring DIM=L	Tolerances
0.5<L<=3.0mm	±0.1mm
3.0<L<=6.0 mm	±0.1mm
6.0<L<=30.0 mm	±0.2mm
30.0<L<=120.0 mm	±0.3mm
120.0<L<=400.0 mm	±0.5mm
400.0<L<=1000.0 mm	±0.8mm

G218MF / G317MF

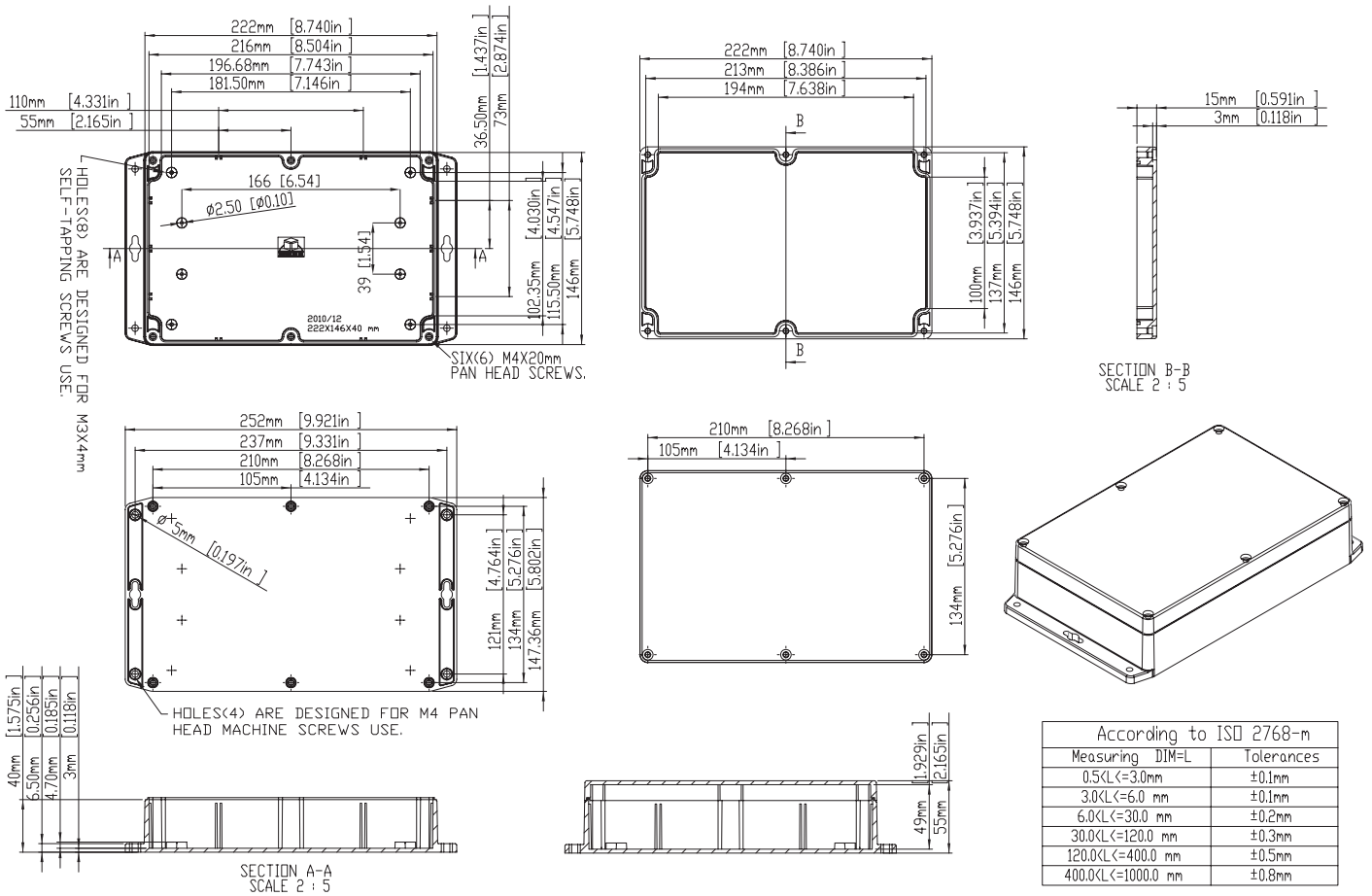

G221MF / G331MF

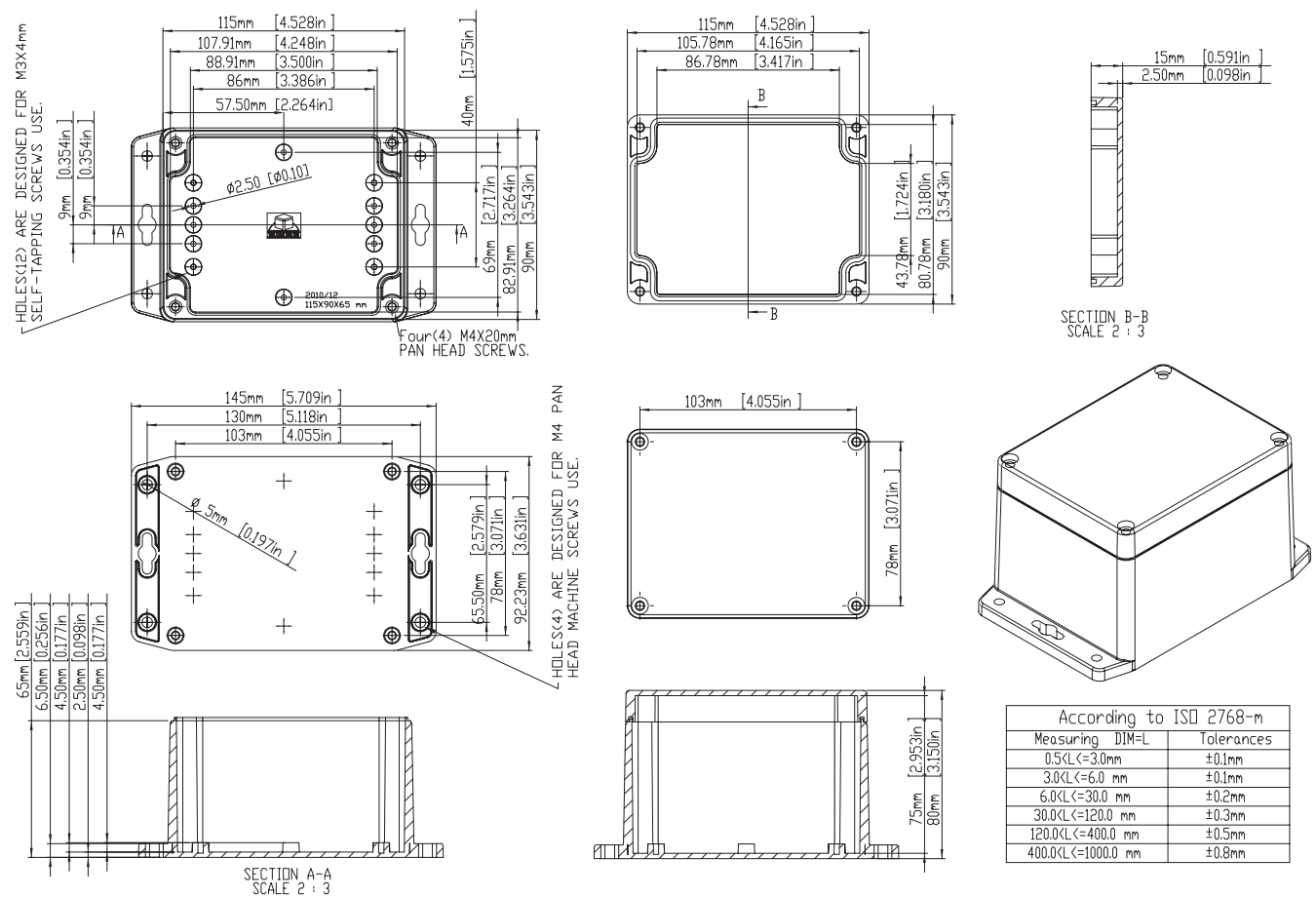

G223MF / G340MF

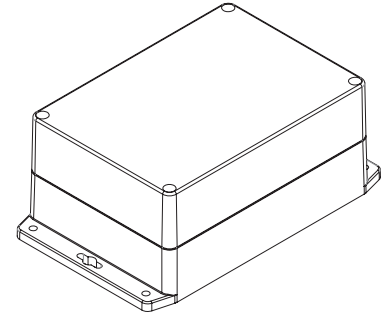
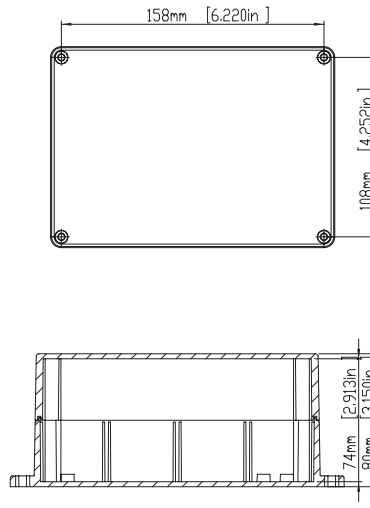
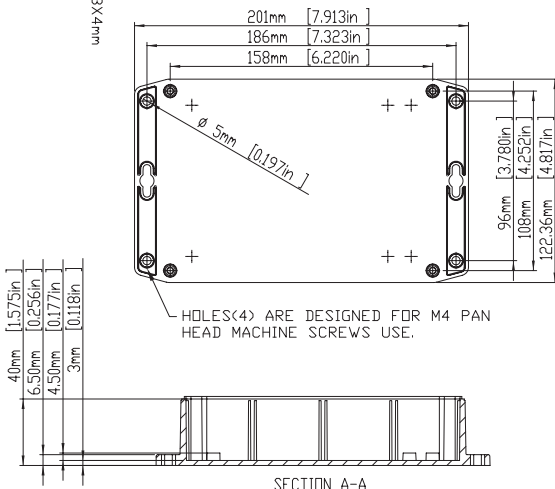
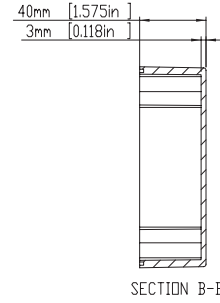
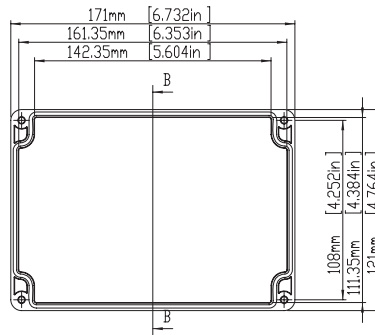
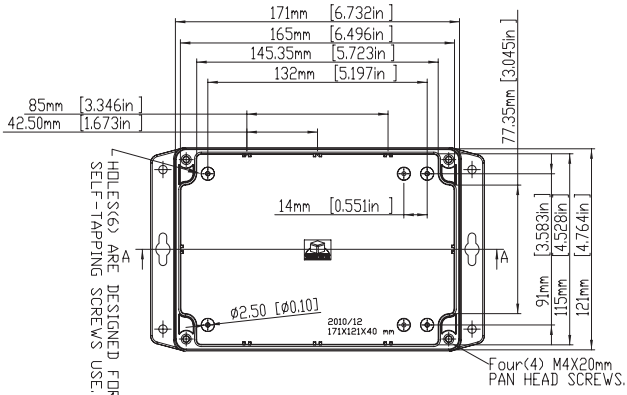

According to ISO 2768-m

Measuring DIM=L	Tolerances
0.5<L<=3.0mm	±0.1mm
3.0<L<=6.0 mm	±0.1mm
6.0<L<=30.0 mm	±0.2mm
30.0<L<=120.0 mm	±0.3mm
120.0<L<=400.0 mm	±0.5mm
400.0<L<=1000.0 mm	±0.8mm

G232MF / G353MF

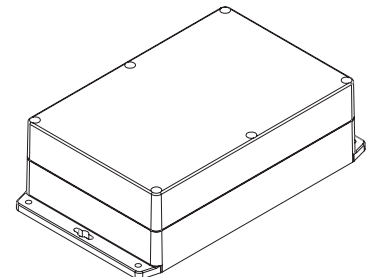
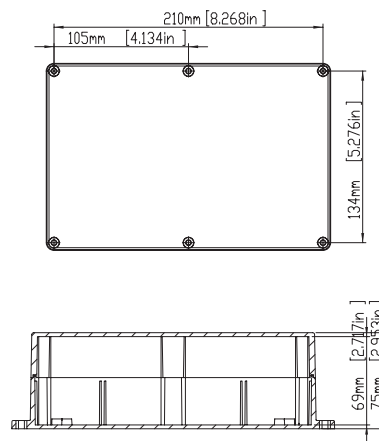
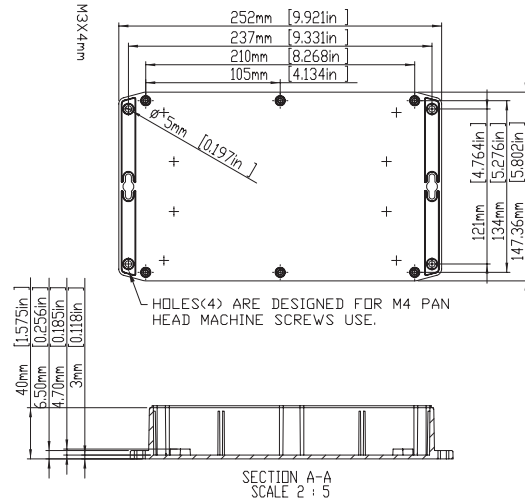
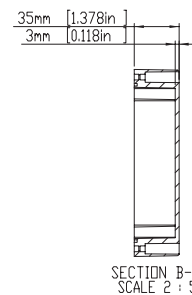
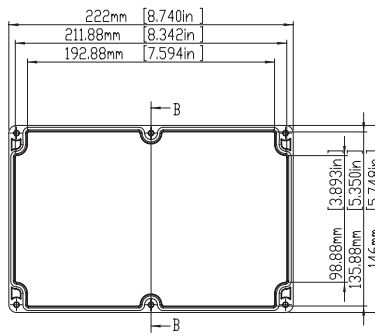
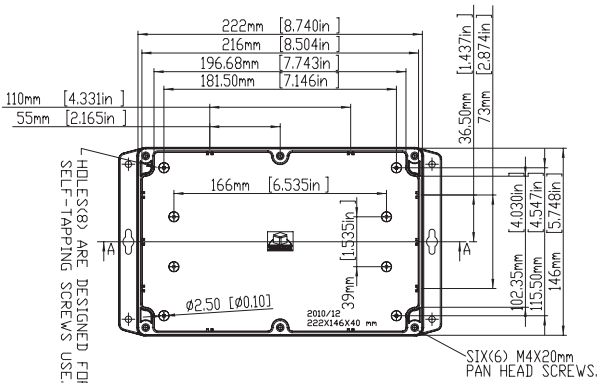

According to ISO 2768-m

Measuring DIM=L	Tolerances
0.5<L<=3.0mm	±0.1mm
3.0<L<=6.0 mm	±0.1mm
6.0<L<=30.0 mm	±0.2mm
30.0<L<=120.0 mm	±0.3mm
120.0<L<=400.0 mm	±0.5mm
400.0<L<=1000.0 mm	±0.8mm

G250MF / G362MF

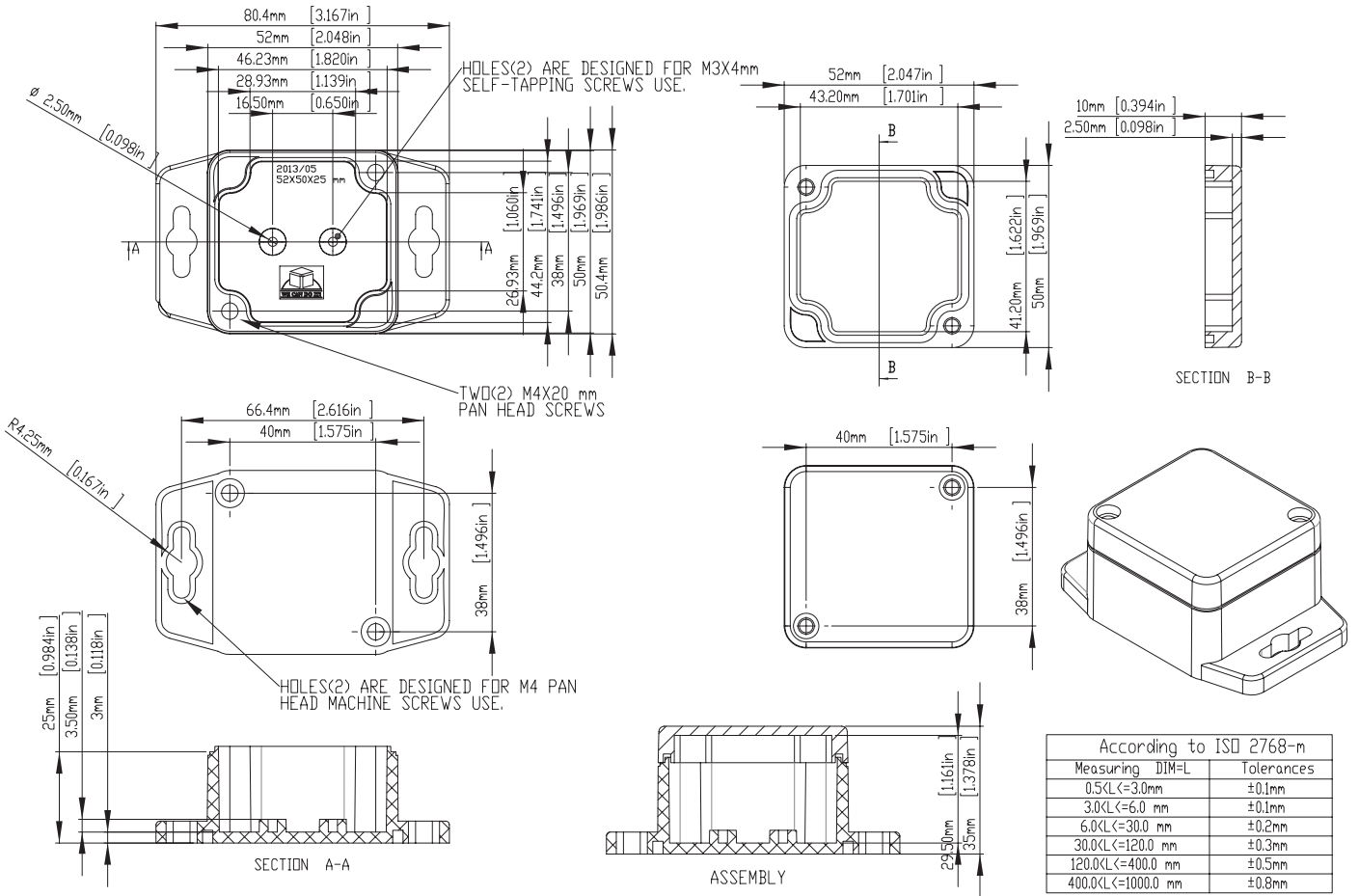

G256MF / G366MF

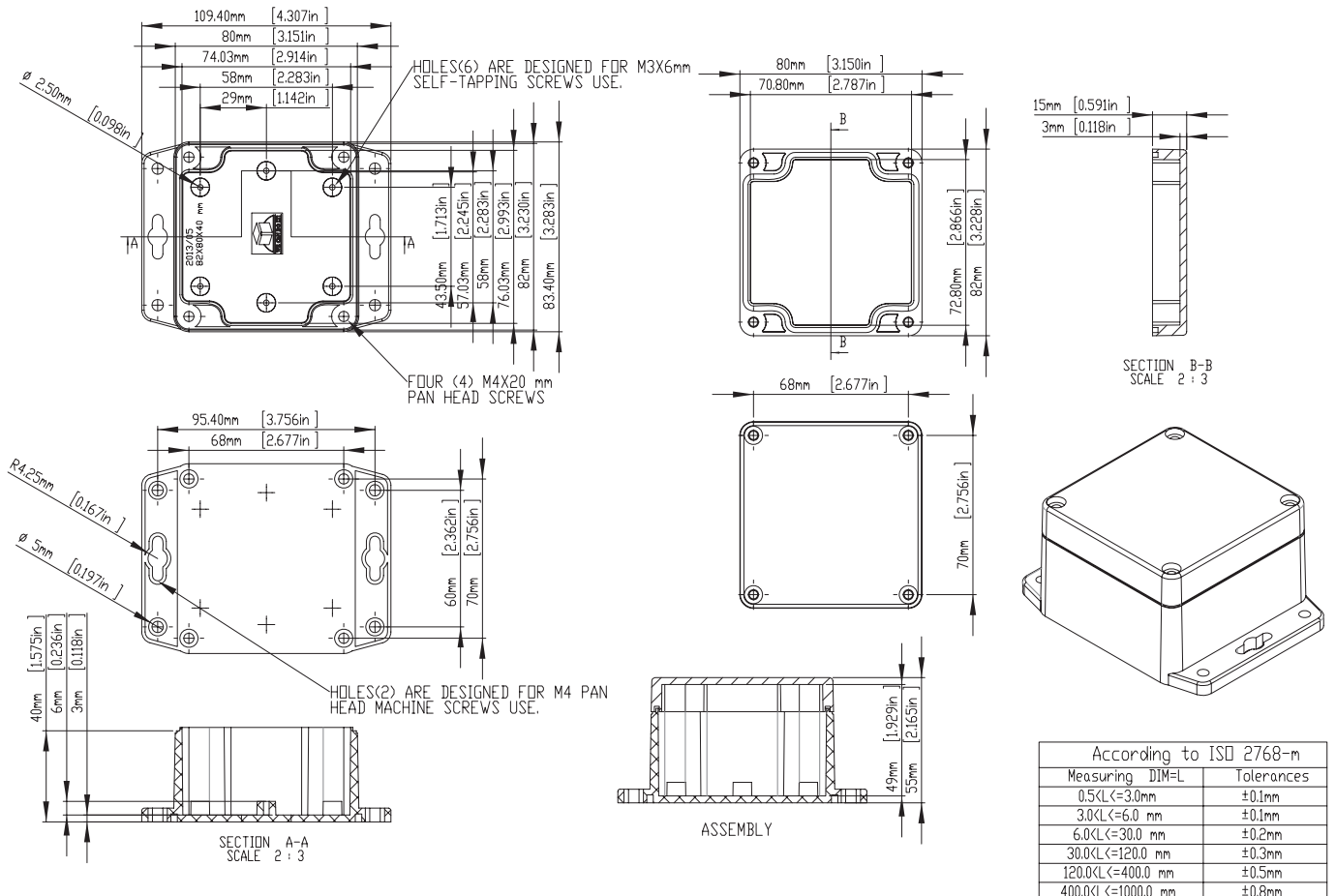

G258MF / G368MF

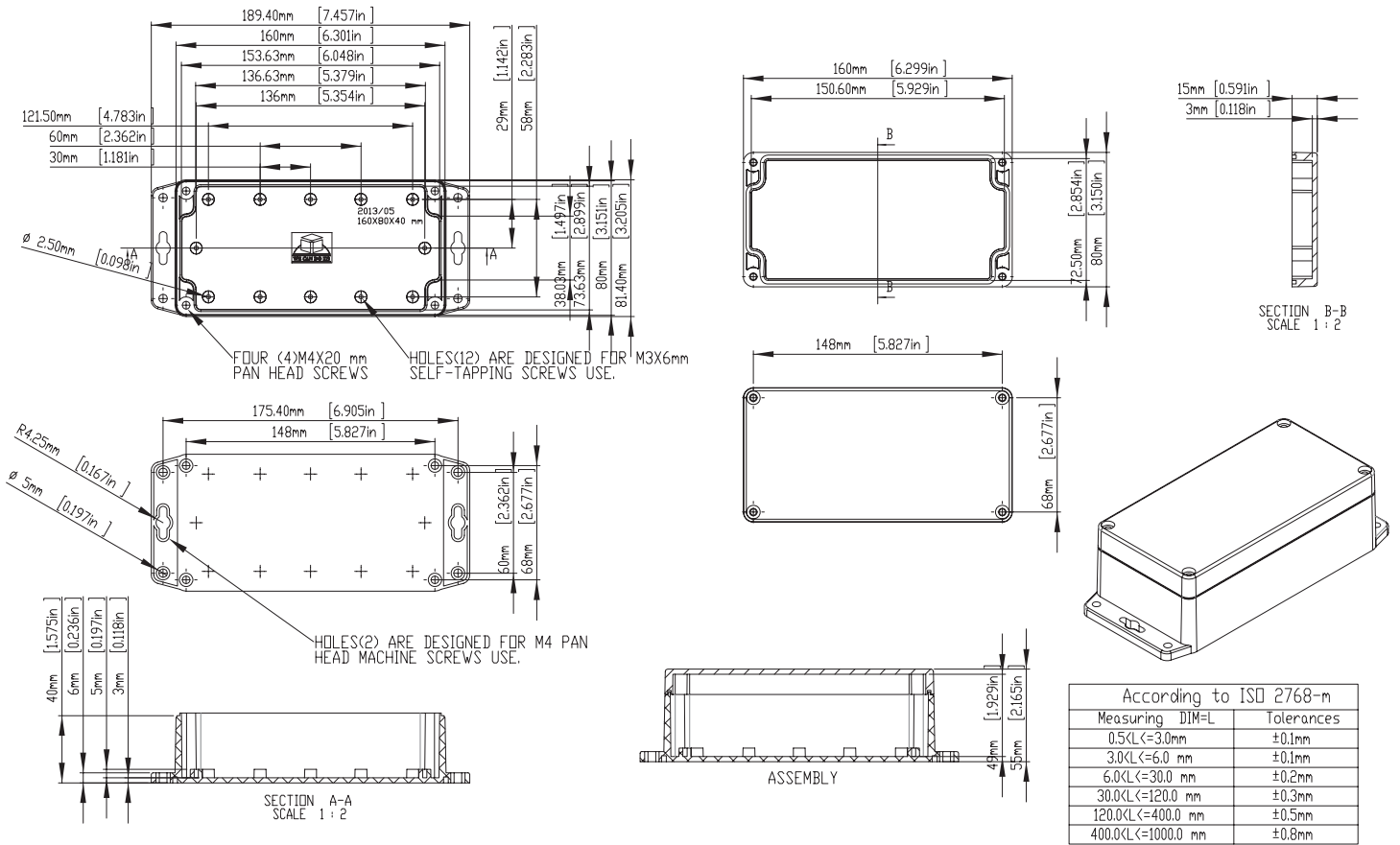

G265MF / G369MF

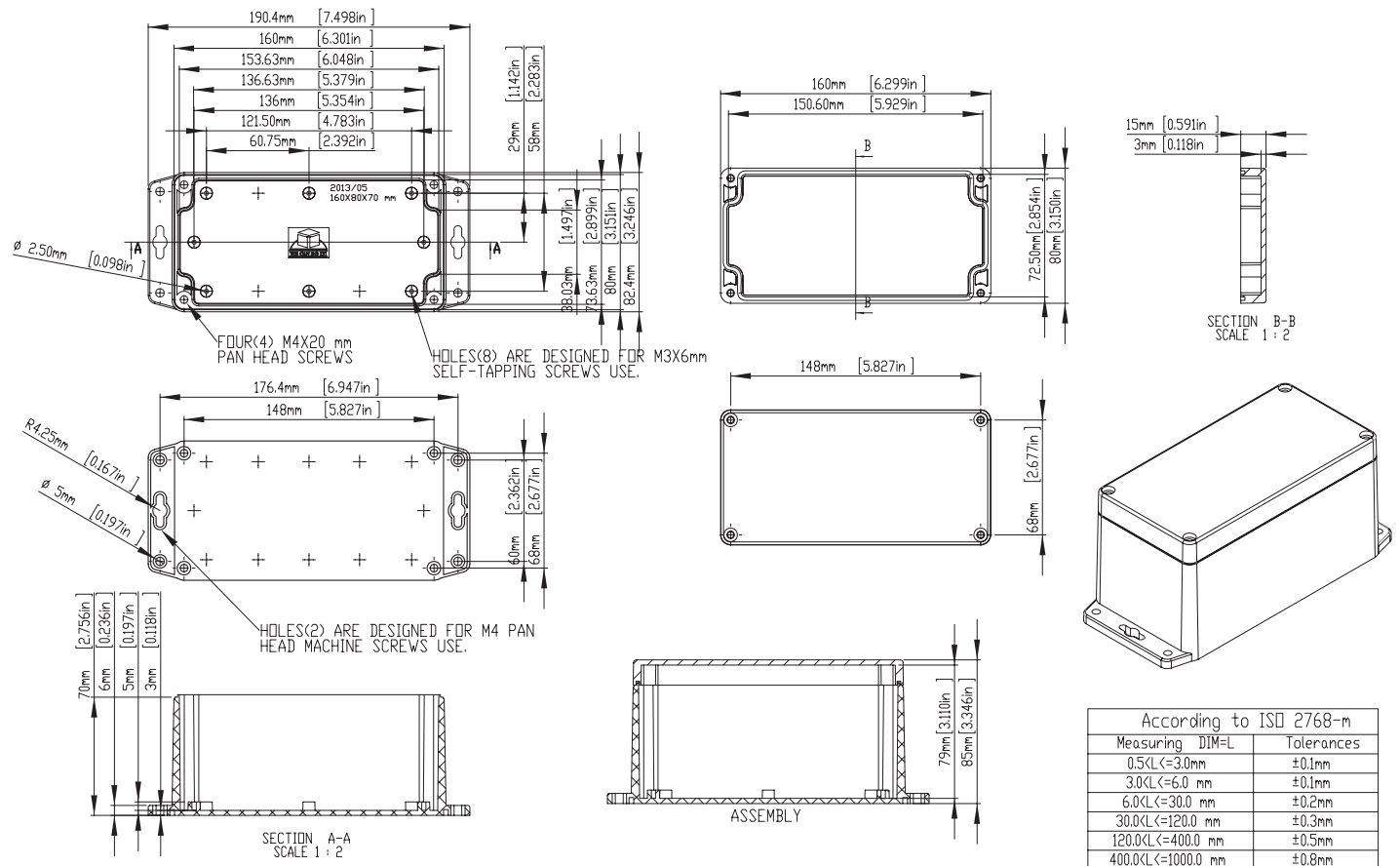

G278MF / G386MF

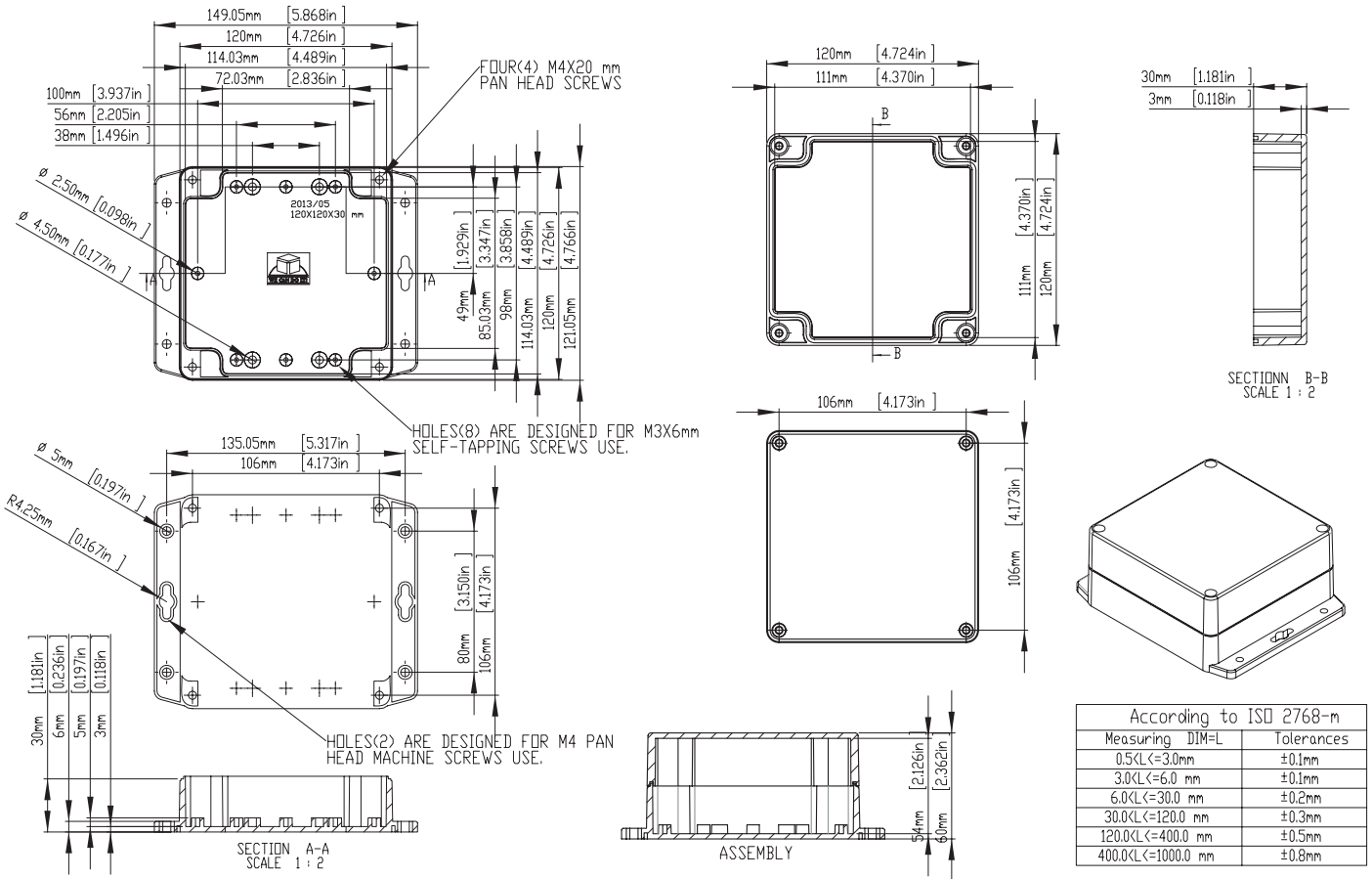

G279MF / G387MF

