

TEW5009 is specifically designed to be used as an isolation transformer in test setups for testing Longitudinal Balance and Return Loss in Primary Rate and Basic Rate Circuits.

Special attention has been given to the problems associated with the coupling capacitance between windings when

transforming from balanced to unbalanced circuits.

- Shield between windings.
- Very low Leakage Inductance.
- Excellent balance.



MECHANICAL

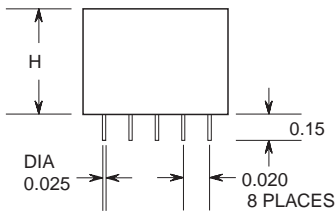

ALL DIMENSIONS ARE IN INCHES

DRILL PATTERN COMPONENT SIDE
2 HOLES DIA. 0.055"
10 HOLES DIA. 0.040"

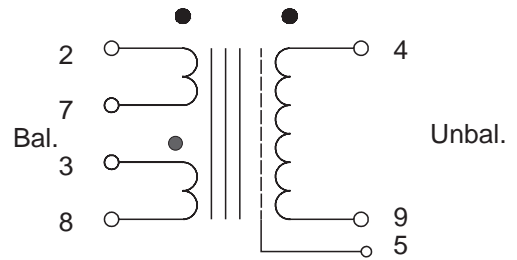
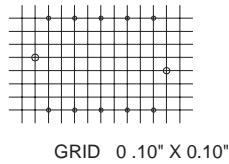
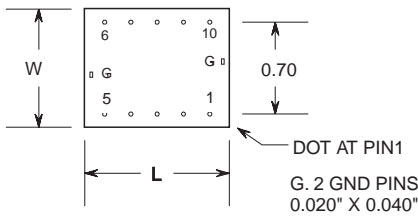

Dimensions	
L	1.15" max.
W	1.00" max.
H	0.85" max

ELECTRICAL SPECIFICATIONS

TEW5009

Impedance	Pri.	(2-7)+(3-8)	100 Ω Bal.	Range, 75 - 150 Ω
	Sec.	(4-9)	100 Ω Unbal.	
Frequency Response			< 1.0 dB	1 KHz - 10 Mhz
Turns ratio		(2-7):(3-8):(4-9)	1 : 1 : 2	
Inductance		(4-9)	> 20 mH	
Leakage Ind.			< 2.0 μH	
Wind. Res.	Pri.	(2-7)+(3-8)	1.92 Ω	
	Sec.	(4-9)	0.97 Ω	
Dielectric Strength			1500 Vrms	

ISSUE: B 93/04/26 TEW5009

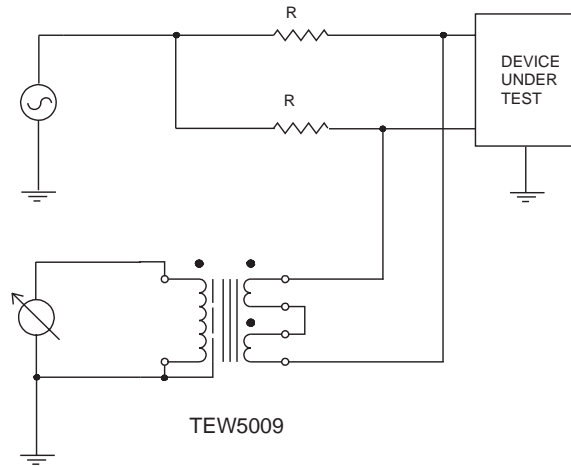

Figure 1: Test circuit for Longitudinal Balance.

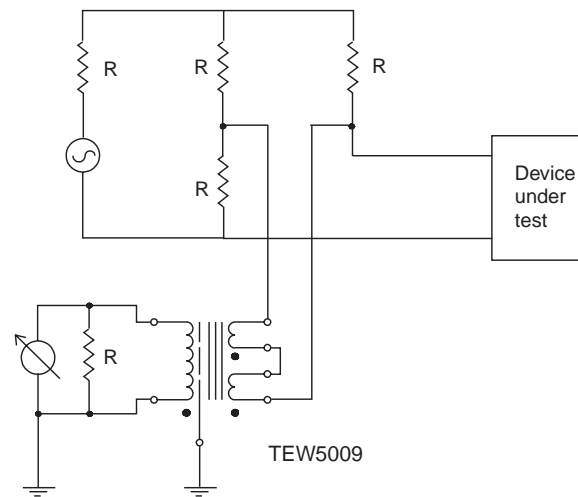

Figure 2: Test circuit for Return Loss