

# DATA SHEET

**P22/13**

**P cores and accessories**

Supersedes data of February 2002

2004 Sep 01



**FERROXCUBE**  
A YAGEO COMPANY

**CORE SETS**

**Effective core parameters**

SYMBOL	PARAMETER	VALUE	UNIT
$\Sigma(l/A)$	core factor (C1)	0.497	mm <sup>-1</sup>
$V_e$	effective volume	2000	mm <sup>3</sup>
$l_e$	effective length	31.5	mm
$A_e$	effective area	63.4	mm <sup>2</sup>
$A_{min}$	minimum area	50.9	mm <sup>2</sup>
m	mass of set	≈ 12	g

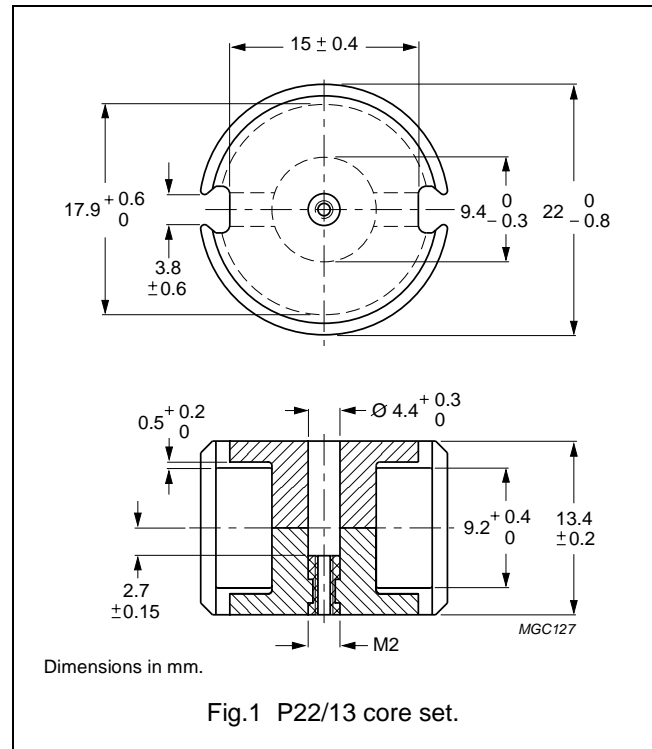

**Core sets for filter applications**

Clamping force for  $A_L$  measurements, 140 ± 30 N.

GRADE	$A_L$ (nH)	$\mu_e$	AIR GAP (μm)	TYPE NUMBER (WITH NUT)	TYPE NUMBER (WITHOUT NUT)
3D3 <sup>sup</sup>	40 ± 3%	≈ 16	≈ 3360	P22/13-3D3-E40/N	P22/13-3D3-E40
	63 ± 3%	≈ 25	≈ 1890	P22/13-3D3-E63/N	P22/13-3D3-E63
	100 ± 3%	≈ 40	≈ 1040	P22/13-3D3-E100/N	P22/13-3D3-E100
	160 ± 3%	≈ 63	≈ 570	P22/13-3D3-E160/N	P22/13-3D3-E160
	1700 ± 25%	≈ 670	≈ 0	–	P22/13-3D3
3H3 <sup>sup</sup>	160 ± 3%	≈ 64	≈ 610	P22/13-3H3-E160/N	P22/13-3H3-E160
	250 ± 3%	≈ 100	≈ 360	P22/13-3H3-E250/N	P22/13-3H3-E250
	315 ± 3%	≈ 125	≈ 270	P22/13-3H3-E315/N	P22/13-3H3-E315
	400 ± 3%	≈ 158	≈ 210	P22/13-3H3-A400/N	P22/13-3H3-A400
	630 ± 3%	≈ 249	≈ 120	P22/13-3H3-A630/N	P22/13-3H3-A630
	3900 ± 25%	≈ 1540	≈ 0	–	P22/13-3H3

**Core sets for general purpose transformers and power applications**Clamping force for  $A_L$  measurements,  $140 \pm 30$  N.

GRADE	$A_L$ (nH)	$\mu_e$	AIR GAP ( $\mu\text{m}$ )	TYPE NUMBER
3C81	$160 \pm 3\%$	$\approx 63$	$\approx 610$	P22/13-3C81-A160
	$250 \pm 3\%$	$\approx 99$	$\approx 360$	P22/13-3C81-A250
	$315 \pm 3\%$	$\approx 125$	$\approx 280$	P22/13-3C81-A315
	$400 \pm 3\%$	$\approx 158$	$\approx 210$	P22/13-3C81-A400
	$630 \pm 3\%$	$\approx 249$	$\approx 120$	P22/13-3C81-A630
	$5200 \pm 25\%$	$\approx 2060$	$\approx 0$	P22/13-3C81
3C91 <small>des</small>	$5200 \pm 25\%$	$\approx 2060$	$\approx 0$	P22/13-3C91
3F3	$160 \pm 3\%$	$\approx 63$	$\approx 610$	P22/13-3F3-A160
	$250 \pm 3\%$	$\approx 99$	$\approx 360$	P22/13-3F3-A250
	$315 \pm 3\%$	$\approx 125$	$\approx 280$	P22/13-3F3-A315
	$400 \pm 3\%$	$\approx 158$	$\approx 210$	P22/13-3F3-A400
	$630 \pm 3\%$	$\approx 249$	$\approx 120$	P22/13-3F3-A630
	$3550 \pm 25\%$	$\approx 1410$	$\approx 0$	P22/13-3F3

**Core sets of high permeability grades**Clamping force for  $A_L$  measurements,  $140 \pm 30$  N.

GRADE	$A_L$ (nH)	$\mu_e$	AIR GAP ( $\mu\text{m}$ )	TYPE NUMBER
3E27	$9250 \pm 25\%$	$\approx 3660$	$\approx 0$	P22/13-3E27

**Properties of core sets under power conditions**

GRADE	B (mT) at	CORE LOSS (W) at			
	H = 250 A/m; f = 25 kHz; T = 100 °C	f = 25 kHz; B = 200 mT; T = 100 °C	f = 100 kHz; B = 100 mT; T = 100 °C	f = 100 kHz; B = 200 mT; T = 100 °C	f = 400 kHz; B = 50 mT; T = 100 °C
3C81	$\geq 320$	$\leq 0.46$	–	–	–
3C91	$\geq 315$	–	$\leq 0.12^{(1)}$	$\leq 0.9^{(1)}$	–
3F3	$\geq 315$	–	$\leq 0.22$	–	$\leq 0.4$

**Note**

1. Measured at 60 °C.

**INDUCTANCE ADJUSTERS**

**General data**

PARAMETER	SPECIFICATION
Material of head and thread	polypropylene (PP), glass fibre reinforced
Maximum operating temperature	125 °C

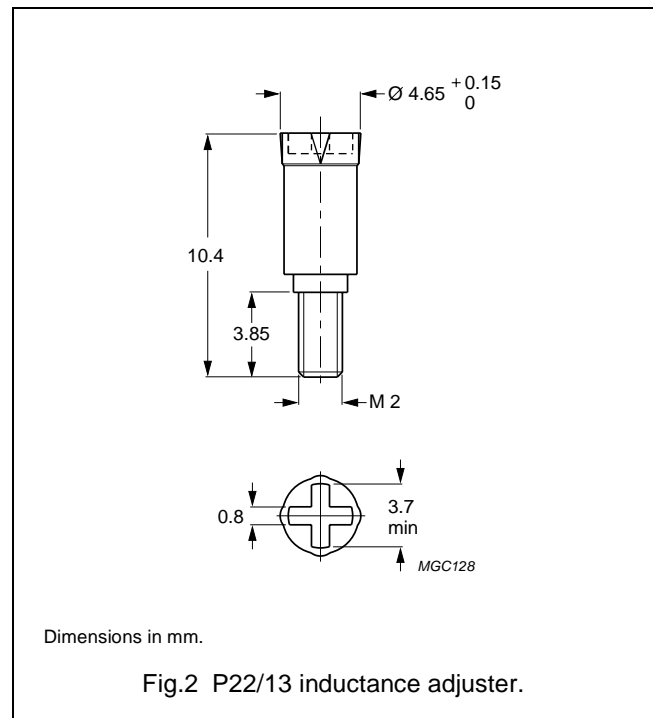

**Inductance adjuster selection chart <sup>sup</sup>( applies to all types)**

GRADE	A <sub>L</sub> (nH)	TYPES FOR LOW ADJUSTMENT	ΔL/L (1)	TYPES FOR MEDIUM ADJUSTMENT	ΔL/L (1)	TYPES FOR HIGH ADJUSTMENT	ΔL/L (1)
3H3	100	–	–	ADJ-P22/RM8-RED	16	ADJ-P22/RM8-ORANGE	21
	160	ADJ-P22/RM8-RED	11	ADJ-P22/RM8-YELLOW	18	ADJ-P22/RM8-WHITE	27
	250	ADJ-P22/RM8-YELLOW	12	ADJ-P22/RM8-WHITE	18	–	–
	315	ADJ-P22/RM8-YELLOW	9	–	–	ADJ-P22/RM8-BROWN	22
	400	ADJ-P22/RM8-WHITE	11	ADJ-P22/RM8-BROWN	17	ADJ-P22/RM8-BLACK	30
	630	ADJ-P22/RM8-BROWN	10	ADJ-P22/RM8-BLACK	18	–	–
	1000	ADJ-P22/RM8-BROWN	6	ADJ-P22/RM8-BLACK	12	–	–
	1250	ADJ-P22/RM8-BROWN	4	ADJ-P22/RM8-BLACK	7	–	–
3D3	40	–	–	–	–	ADJ-P22/RM8-ORANGE	27
	63	–	–	–	–	ADJ-P22/RM8-ORANGE	26
	100	–	–	ADJ-P22/RM8RED	16	ADJ-P22/RM8-YELLOW	27
	160	ADJ-P22/RM8-RED	10	ADJ-P22/RM8-YELLOW	17	–	–
	250	ADJ-P22/RM8-YELLOW	–	–	–	–	–

**Note**

1. Maximum adjustment range.

**COIL FORMERS**

**General data CP-P22/13 coil former**

PARAMETER	SPECIFICATION
Coil former material	polybutyleneterephthalate (PBT), glass reinforced, flame retardant in accordance with "UL 94V-0"; UL file number E45329 (R)
Maximum operating temperature	155 °C, "IEC 60085", class F

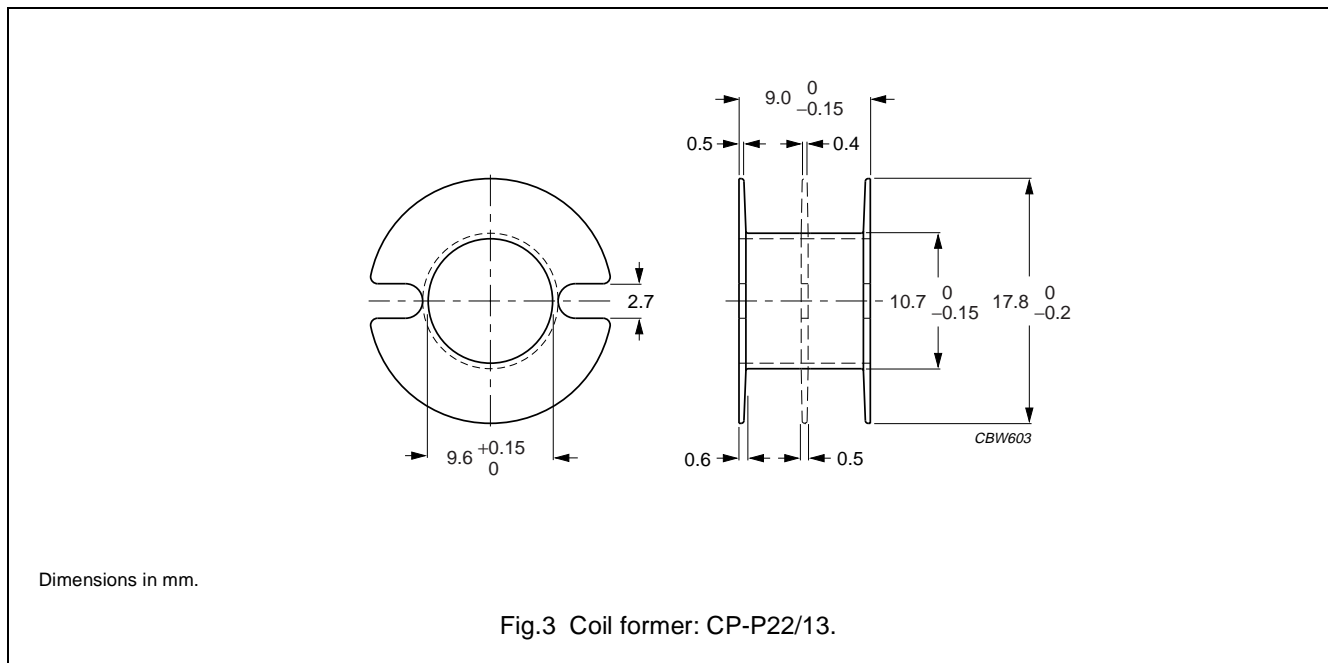

**Winding data for CP-P22/13 coil former**

NUMBER OF SECTIONS	MINIMUM WINDING AREA (mm <sup>2</sup> )	NOMINAL WINDING WIDTH (mm)	AVERAGE LENGTH OF TURN (mm)	TYPE NUMBER
1	26.2	7.5	44.5	CP-P22/13-1S
2	2 × 12.2	2 × 3.45	44.5	CP-P22/13-2S
3	3 × 7.6	3 × 2.1	44.5	CP-P22/13-3S

**General data 6-pins P22/13 coil former for PCB mounting**

PARAMETER	SPECIFICATION
Coil former material	polyamide (PA6.6), glass reinforced, flame retardant in accordance with "UL 94V-0"; UL file number E41938(M)
Maximum operating temperature	130 °C, "IEC 60085", class B
Pin material	copper-zinc alloy (CuZn), tin-lead alloy (SnPb) plated, transition to lead-free (Sn) ongoing
Resistance to soldering heat	"IEC 60068-2-20", Part 2, Test Tb, method 1B, 350 °C, 3.5 s
Solderability	"IEC 60068-2-20", Part 2, Test Ta, method 1, 235 °C, 2 s

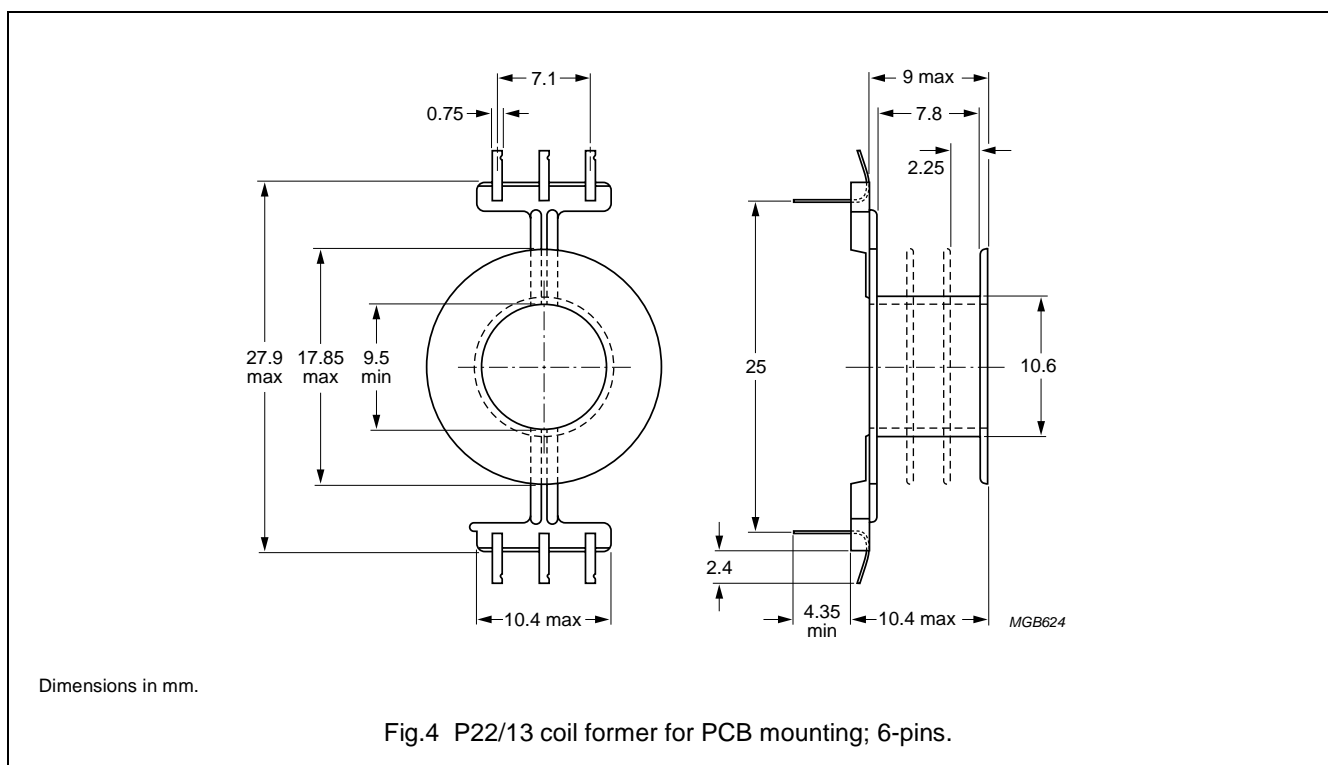

**Data for 6-pins P22/13 coil former for PCB mounting**

NUMBER OF SECTIONS	MINIMUM WINDING AREA (mm <sup>2</sup> )	NOMINAL WINDING WIDTH (mm)	AVERAGE LENGTH OF TURN (mm)	MINIMUM LENGTH OF PINS (mm)	TYPE NUMBER
1	25.2	7.8	44.5	4.4	CPV-P22/13-1S-6PD
1	25.2	7.8	44.5	6.8	CPV-P22/13-1S-6PDL
2	2 × 11.7	2 × 3.6	44.5	4.4	CPV-P22/13-2S-6PD
2	2 × 11.7	2 × 3.6	44.5	6.8	CPV-P22/13-2S-6PDL
3	3 × 7.03	3 × 2.2	44.5	4.4	CPV-P22/13-3S-6PD <sup>(1)</sup>
3	3 × 7.03	3 × 2.2	44.5	6.8	CPV-P22/13-3S-6PDL <sup>(1)</sup>

**Note**

1. In accordance with "UL 94-HB".

**MOUNTING PARTS**

**General data and ordering information**

ITEM	REMARKS	FIGURE	TYPE NUMBER
Tag plate	material: phenolformaldehyde (PF), glass reinforced	5	TGP-P22/13-8P
	flame retardant: in accordance with "UL 94V-0"; UL file number E167521(M)		
	maximum operating temperature: 180 °C, "IEC 60085", class H		
	pins: copper-tin alloy (CuSn), tin-lead alloy (SnPb) plated		
	resistance to soldering heat in accordance with "IEC 60068-2-20", Part 2, Test Tb, method 1B: 350 °C, 3.5 s		
	solderability in accordance with "IEC 60068-2-20", Part 2, Test Ta, method 1: 235 °C, 2 s		
Container	copper-zinc alloy (CuZn), SnPb-plated, transition to lead-free (Sn) ongoing	6	CON-P22/13
	earth pins: presoldered		
Spring	CrNi-steel	7	SPR-P22/13
	spring force: ≈140 N when mounted		
Clamp	spring steel, tin-plated	8	CLM/TS-P22/13
Washer	phenolformaldehyde (PF)	9	WAS-CLM/TS-P22/13

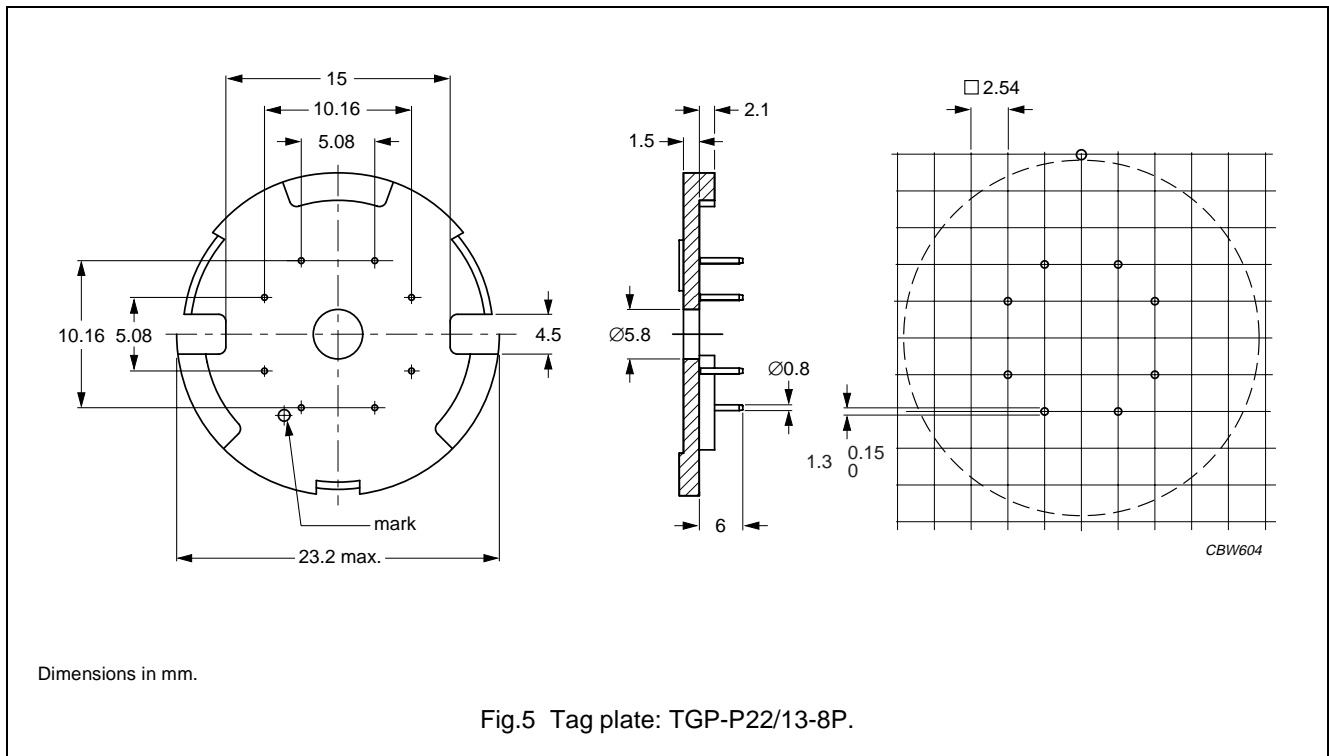

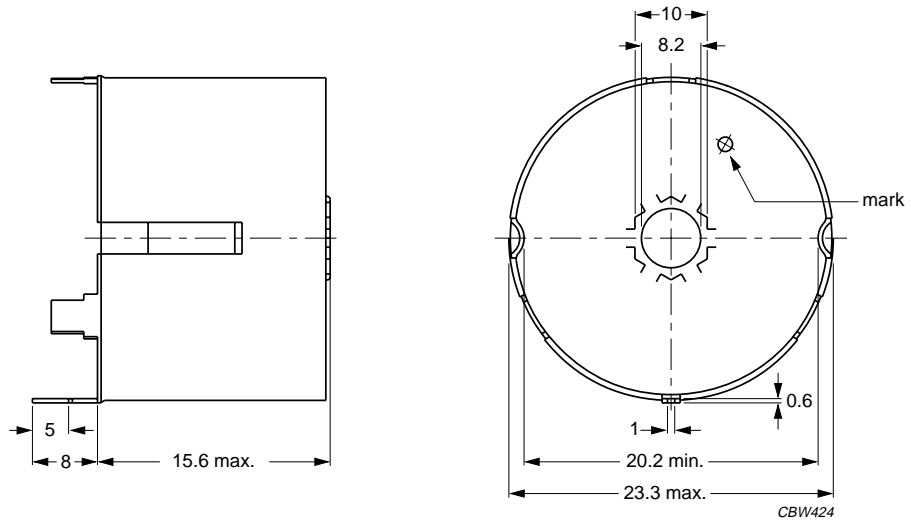

Dimensions in mm.

Fig.6 Container: CON-P22/13.

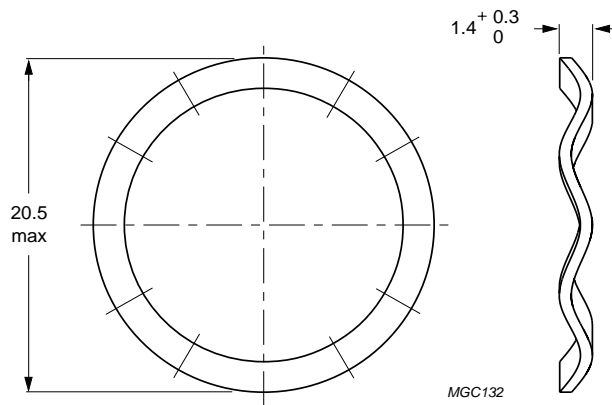

Dimensions in mm.

Fig.7 Spring: SPR-P22/13.

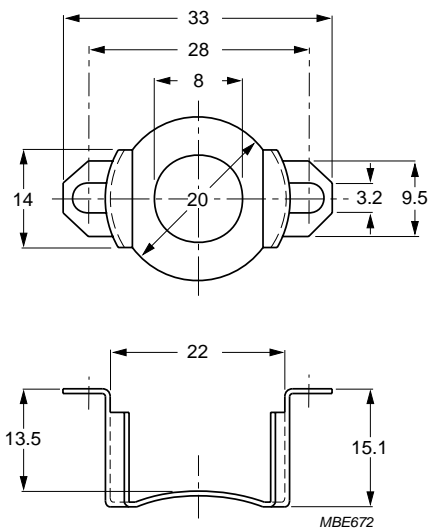

Dimensions in mm.

Fig.8 Clamp: CLM/S-P22/13.

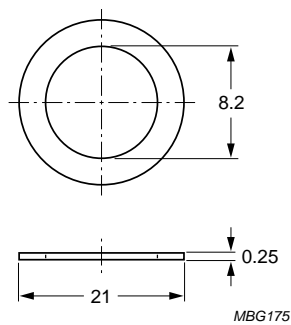

Dimensions in mm.

Fig.9 Washer: WAS-CLM/TS-P22/13.



**DATA SHEET STATUS DEFINITIONS**

DATA SHEET STATUS	PRODUCT STATUS	DEFINITIONS
Preliminary specification	Development	This data sheet contains preliminary data. Ferroxcube reserves the right to make changes at any time without notice in order to improve design and supply the best possible product.
Product specification	Production	This data sheet contains final specifications. Ferroxcube reserves the right to make changes at any time without notice in order to improve design and supply the best possible product.

**DISCLAIMER**

**Life support applications** — These products are not designed for use in life support appliances, devices, or systems where malfunction of these products can reasonably be expected to result in personal injury. Ferroxcube customers using or selling these products for use in such applications do so at their own risk and agree to fully indemnify Ferroxcube for any damages resulting from such application.

**PRODUCT STATUS DEFINITIONS**

STATUS	INDICATION	DEFINITION
<b>Prototype</b>		These are products that have been made as development samples for the purposes of technical evaluation only. The data for these types is provisional and is subject to change.
<b>Design-in</b>		These products are recommended for new designs.
<b>Preferred</b>		These products are recommended for use in current designs and are available via our sales channels.
<b>Support</b>		These products are <b>not</b> recommended for new designs and may not be available through all of our sales channels. Customers are advised to check for availability.