

# DATA SHEET

**ETD59/31/22**

**ETD cores and accessories**

Supersedes data of February 2002

2004 Sep 01

**CORE SETS**

**Effective core parameters**

SYMBOL	PARAMETER	VALUE	UNIT
$\Sigma(l/A)$	core factor (C1)	0.378	mm <sup>-1</sup>
$V_e$	effective volume	51500	mm <sup>3</sup>
$l_e$	effective length	139	mm
$A_e$	effective area	368	mm <sup>2</sup>
$A_{min}$	minimum area	360	mm <sup>2</sup>
m	mass of core half	≈130	g

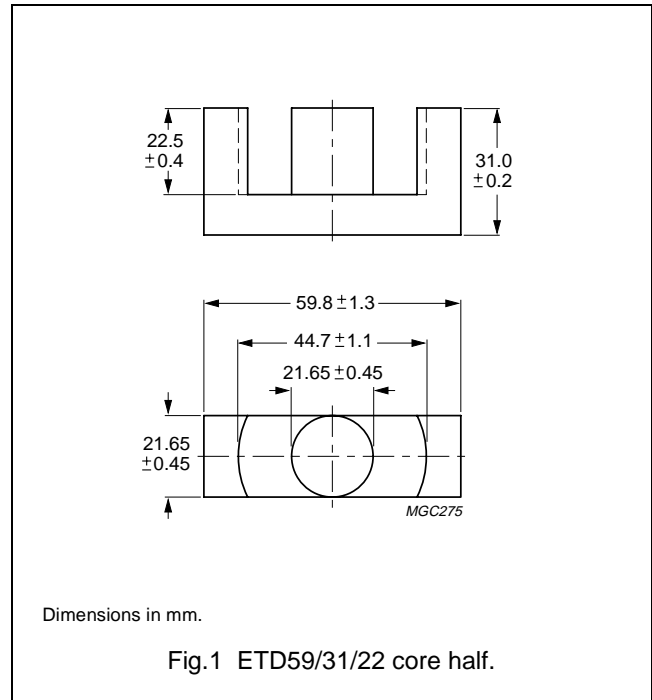

**Core halves**

Clamping force for  $A_L$  measurements, 70 ± 20 N. Gapped cores are available on request.

GRADE	$A_L$ (nH)	$\mu_e$	AIR GAP (μm)	TYPE NUMBER
3C90	6000 ± 25%	≈ 1800	≈ 0	ETD59/31/22-3C90
3C94	6000 ± 25%	≈ 1800	≈ 0	ETD59/31/22-3C94
3F3	5600 ± 25%	≈ 1680	≈ 0	ETD59/31/22-3F3

**Properties of core sets under power conditions**

GRADE	B (mT) at	CORE LOSS (W) at			
	H = 250 A/m; f = 25 kHz; T = 100 °C	f = 25 kHz; $\hat{B}$ = 200 mT; T = 100 °C	f = 100 kHz; $\hat{B}$ = 100 mT; T = 100 °C	f = 100 kHz; $\hat{B}$ = 200 mT; T = 100 °C	f = 400 kHz; $\hat{B}$ = 50 mT; T = 100 °C
3C90	≥ 330	≤ 6.2	≤ 7.3	–	–
3C94	≥ 330	–	≤ 5.2	≤ 31	–
3F3	≥ 320	–	≤ 6.7	–	≤ 12.8

**COIL FORMER**

**General data 24-pins ETD59/31/22 coil former**

PARAMETER	SPECIFICATION
Coil former material	polybutyleneterephthalate (PBT), glass-reinforced, flame retardant in accordance with "UL 94V-0"; UL file number E45329(M)
Pin material	copper-tin alloy (CuSn), tin-lead alloy (SnPb) plated, transition to lead-free (Sn) ongoing.
Maximum operating temperature	155 °C, "IEC 60085", class F
Resistance to soldering heat	"IEC 60068-2-20", Part 2, Test Tb, method 1B, 350 °C, 3.5 s
Solderability	"IEC 60068-2-20", Part 2, Test Ta, method 1

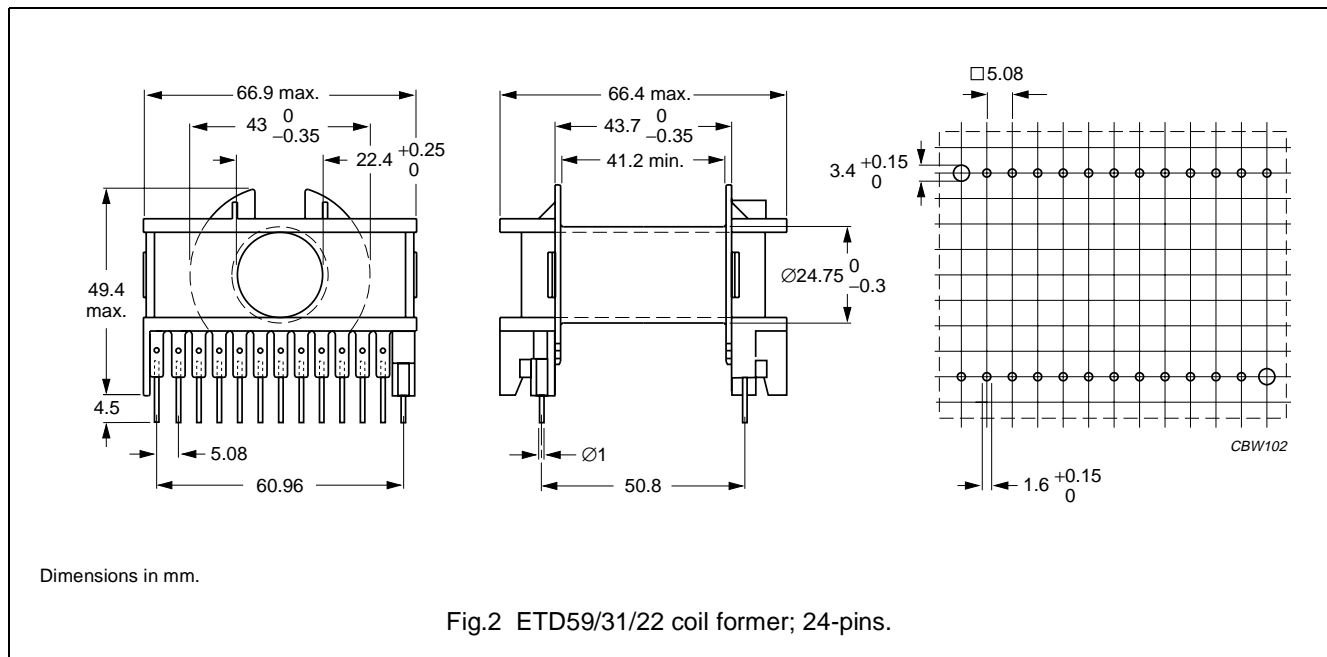

**Winding data for 24-pins ETD59/31/22 coil former**

NUMBER OF SECTIONS	WINDING AREA (mm <sup>2</sup> )	MINIMUM WINDING WIDTH (mm)	AVERAGE LENGTH OF TURN (mm)	TYPE NUMBER
1	366	41.2	106	CPH-ETD59-1S-24P

**MOUNTING PARTS**

**General data**

ITEM	REMARKS	FIGURE	TYPE NUMBER
Mounting clip	material: stainless steel	3	CLI-ETD59

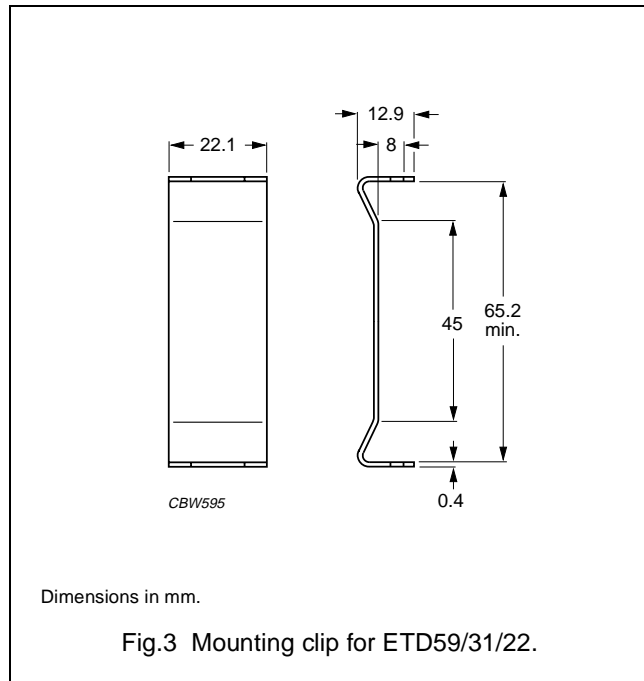



**DATA SHEET STATUS DEFINITIONS**

DATA SHEET STATUS	PRODUCT STATUS	DEFINITIONS
Preliminary specification	Development	This data sheet contains preliminary data. Ferroxcube reserves the right to make changes at any time without notice in order to improve design and supply the best possible product.
Product specification	Production	This data sheet contains final specifications. Ferroxcube reserves the right to make changes at any time without notice in order to improve design and supply the best possible product.

**DISCLAIMER**

**Life support applications** — These products are not designed for use in life support appliances, devices, or systems where malfunction of these products can reasonably be expected to result in personal injury. Ferroxcube customers using or selling these products for use in such applications do so at their own risk and agree to fully indemnify Ferroxcube for any damages resulting from such application.

**PRODUCT STATUS DEFINITIONS**

STATUS	INDICATION	DEFINITION
<b>Prototype</b>		These are products that have been made as development samples for the purposes of technical evaluation only. The data for these types is provisional and is subject to change.
<b>Design-in</b>		These products are recommended for new designs.
<b>Preferred</b>		These products are recommended for use in current designs and are available via our sales channels.
<b>Support</b>		These products are <b>not</b> recommended for new designs and may not be available through all of our sales channels. Customers are advised to check for availability.