

DATA SHEET

EFD20/10/7

EFD cores and accessories

Supersedes data of February 2002

2004 Sep 01

CORES

Effective core parameters

SYMBOL	PARAMETER	VALUE	UNIT
$\Sigma(l/A)$	core factor (C1)	1.52	mm ⁻¹
V_e	effective volume	1460	mm ³
l_e	effective length	47.0	mm
A_e	effective area	31.0	mm ²
A_{min}	minimum area	29	mm ²
m	mass of core half	≈ 3.5	g

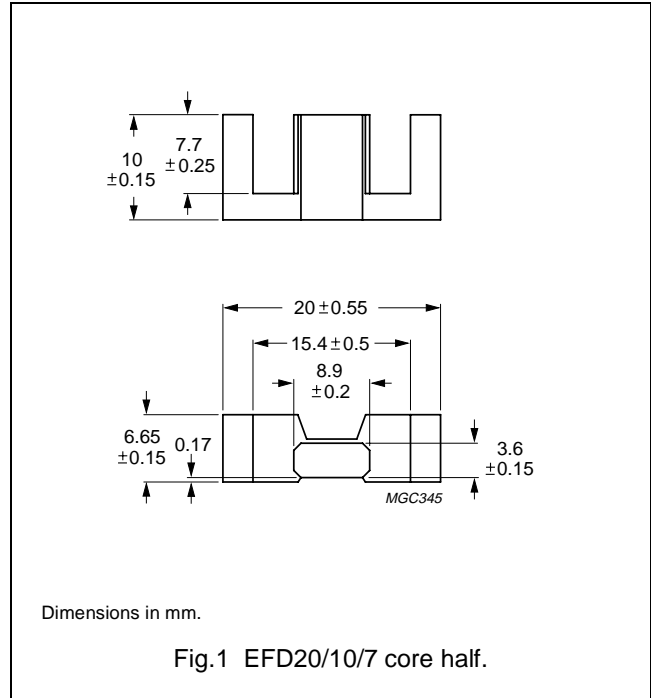

Core halves

A_L measured in combination with a non-gapped core half, clamping force for A_L measurements 20 ±10 N, unless stated otherwise.

GRADE	A_L (nH)	μ_e	AIR GAP (μ m)	TYPE NUMBER
3C90	63 ±3% ⁽¹⁾	≈ 76	≈ 960	EFD20/10/7-3C90-E63
	100 ±3%	≈ 121	≈ 510	EFD20/10/7-3C90-A100
	160 ±5%	≈ 193	≈ 280	EFD20/10/7-3C90-A160
	250 ±8%	≈ 302	≈ 160	EFD20/10/7-3C90-A250
	315 ±10%	≈ 380	≈ 120	EFD20/10/7-3C90-A315
	1300 ±25%	≈ 1570	≈ 0	EFD20/10/7-3C90
3C94	63 ±3% ⁽¹⁾	≈ 76	≈ 960	EFD20/10/7-3C94-E63
	100 ±3%	≈ 121	≈ 510	EFD20/10/7-3C94-A100
	160 ±5%	≈ 193	≈ 280	EFD20/10/7-3C94-A160
	250 ±8%	≈ 302	≈ 160	EFD20/10/7-3C94-A250
	315 ±10%	≈ 380	≈ 120	EFD20/10/7-3C94-A315
	1300 ±25%	≈ 1570	≈ 0	EFD20/10/7-3C94
3C96 <small>des</small>	1200 ±25%	≈ 1450	≈ 0	EFD20/10/7-3C96
3F3	63 ±3% ⁽¹⁾	≈ 76	≈ 960	EFD20/10/7-3F3-E63
	100 ±3%	≈ 121	≈ 510	EFD20/10/7-3F3-A100
	160 ±5%	≈ 193	≈ 280	EFD20/10/7-3F3-A160
	250 ±8%	≈ 302	≈ 160	EFD20/10/7-3F3-A250
	315 ±10%	≈ 380	≈ 120	EFD20/10/7-3F3-A315
	1200 ±25%	≈ 1450	≈ 0	EFD20/10/7-3F3

GRADE	A_L (nH)	μ_e	AIR GAP (μm)	TYPE NUMBER
3F35 <small>des</small>	920 \pm 25%	\approx 1110	\approx 0	EFD20/10/7-3F35
3F4 <small>des</small>	63 \pm 3% ⁽¹⁾	\approx 76	\approx 900	EFD20/10/7-3F4-E63
	100 \pm 3%	\approx 121	\approx 450	EFD20/10/7-3F4-A100
	160 \pm 5%	\approx 193	\approx 230	EFD20/10/7-3F4-A160
	250 \pm 8%	\approx 302	\approx 120	EFD20/10/7-3F4-A250
	315 \pm 10%	\approx 380	\approx 80	EFD20/10/7-3F4-A315
	650 \pm 25%	\approx 780	\approx 0	EFD20/10/7-3F4
3F45 <small>prot</small>	650 \pm 25%	\approx 780	\approx 0	EFD20/10/7-3F45

Note

1. Measured in combination with an equal gapped core half, clamping force for A_L measurements, 20 \pm 10 N.

Properties of core sets under power conditions

GRADE	B (mT) at	CORE LOSS (W) at			
	H = 250 A/m; f = 25 kHz; T = 100 °C	f = 25 kHz; \hat{B} = 200 mT; T = 100 °C	f = 100 kHz; \hat{B} = 100 mT; T = 100 °C	f = 100 kHz; \hat{B} = 200 mT; T = 100 °C	f = 400 kHz; \hat{B} = 50 mT; T = 100 °C
3C90	\geq 330	\leq 0.16	\leq 0.17	–	–
3C94	\geq 330	–	\leq 0.13	\leq 0.8	–
3C96	\geq 330	–	\leq 0.1	\leq 0.6	\leq 0.26
3F35	\geq 300	–	–	–	\leq 0.13
3F3	\geq 315	–	\leq 0.17	–	\leq 0.28
3F4	\geq 300	–	–	–	–

Properties of core sets under power conditions (continued)

GRADE	B (mT) at	CORE LOSS (W) at				
	H = 250 A/m; f = 25 kHz; T = 100 °C	f = 500 kHz; \hat{B} = 50 mT; T = 100 °C	f = 500 kHz; \hat{B} = 100 mT; T = 100 °C	f = 1 MHz; \hat{B} = 30 mT; T = 100 °C	f = 1 MHz; \hat{B} = 50 mT; T = 100 °C	f = 3 MHz; \hat{B} = 10 mT; T = 100 °C
3C90	\geq 330	–	–	–	–	–
3C94	\geq 330	–	–	–	–	–
3C96	\geq 330	\leq 0.5	–	–	–	–
3F35	\geq 300	\leq 0.2	\leq 1.5	–	–	–
3F3	\geq 315	–	–	–	–	–
3F4	\geq 300	–	–	\leq 0.4	–	\leq 0.7
3F45	\geq 300	–	–	\leq 0.3	\leq 0.73	\leq 0.5

COIL FORMERS

General data

PARAMETER	SPECIFICATION
Coil former material	phenolformaldehyde (PF), glass-reinforced, flame retardant in accordance with "UL94 V-0"; UL file number E167521(M)
Pin material	copper-tin alloy (CuSn), Ni flash, tin-lead alloy (SnPb) plated, see note 1
Maximum operating temperature	180 °C, "IEC 60085", class H
Resistance to soldering heat	"IEC 60068-2-20", Part 2, Test Tb, method 1B, 350 °C, 3.5 s
Solderability	"IEC 60068-2-20", Part 2, Test Ta, method 1: 235 °C, 2 s

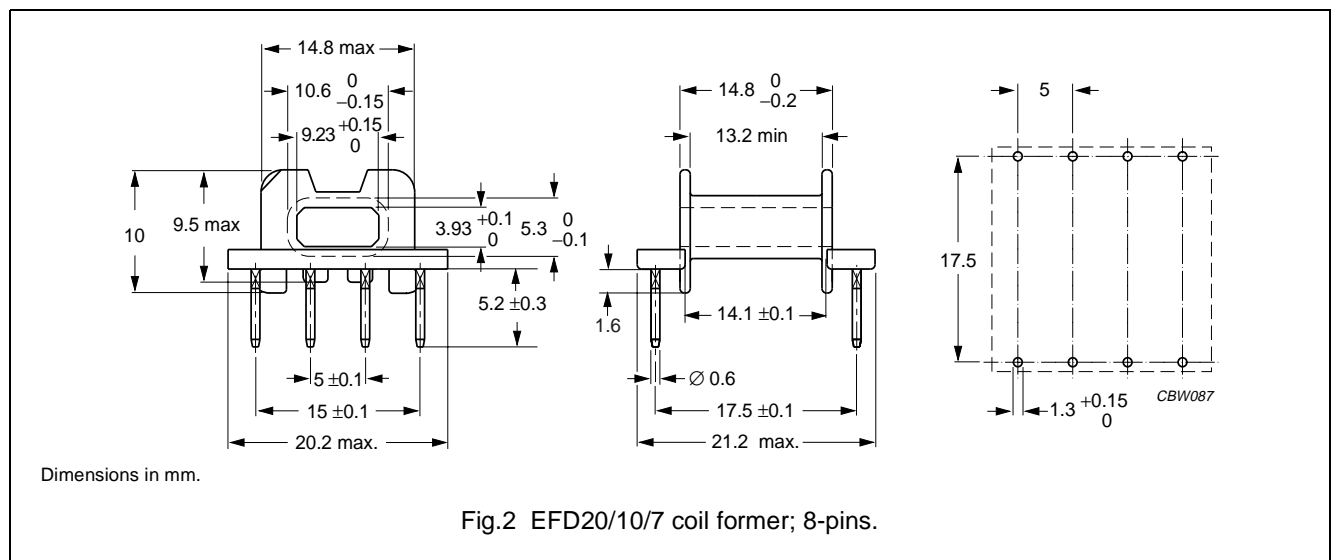

Winding data for EFD20 coil former with 8-pins

NUMBER OF SECTIONS	WINDING AREA (mm ²)	MINIMUM WINDING WIDTH (mm)	AVERAGE LENGTH OF TURN (mm)	TYPE NUMBER
1	26.4	13.2	36.5	CSH-EFD20-1S-8P; see note 1

Note

- Also available with post-inserted lead-free pins.

COIL FORMERS

General data

PARAMETER	SPECIFICATION
Coil former material	liquid crystal polymer (LCP), glass reinforced, flame retardant in accordance with "UL94 V-0"; UL file number E54705 (M)
Pin material	copper-tin alloy (CuSn), Ni flash, tin (Sn) plated
Maximum operating temperature	155 °C, "IEC 60085", class F
Resistance to soldering heat	"IEC 60068-2-20", Part 2, Test Tb, method 1B, 350 °C, 3.5 s
Solderability	"IEC 60068-2-20", Part 2, Test Ta, method 1: 235 °C, 2 s

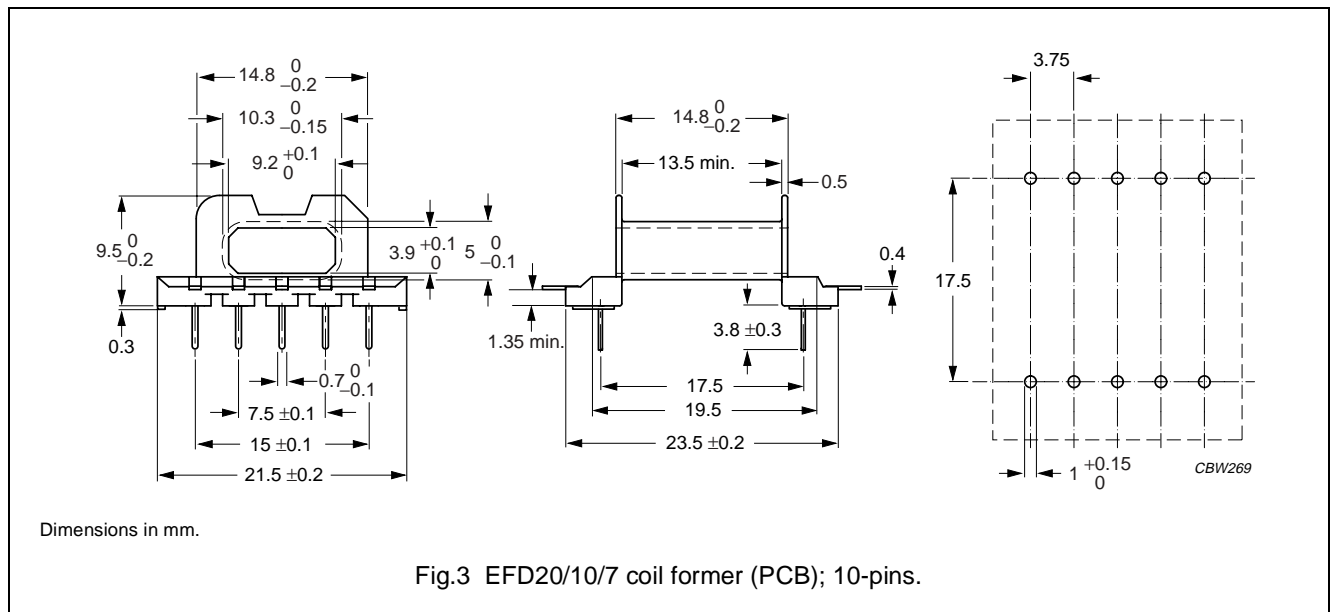

Winding data for EFD20/10/7 coil former (PCB) with 10-pins

NUMBER OF SECTIONS	WINDING AREA (mm ²)	MINIMUM WINDING WIDTH (mm)	AVERAGE LENGTH OF TURN (mm)	TYPE NUMBER
1	27.7	13.5	34.1	CPH-EFD20-1S-10PD-Z

COIL FORMERS

General data

PARAMETER	SPECIFICATION
Coil former material	liquid crystal polymer (LCP), glass reinforced, flame retardant in accordance with "UL94 V-0"; UL file number E83005 (M)
Pin material	copper-tin alloy (CuSn), tin-lead alloy (SnPb) plated, transition to lead-free (Sn) ongoing.
Maximum operating temperature	155 °C, "IEC 60085", class F
Resistance to soldering heat	"IEC 60068-2-20", Part 2, Test Tb, method 1B, 350 °C, 3.5 s
Solderability	"IEC 60068-2-20", Part 2, Test Ta, method 1: 235 °C, 2 s

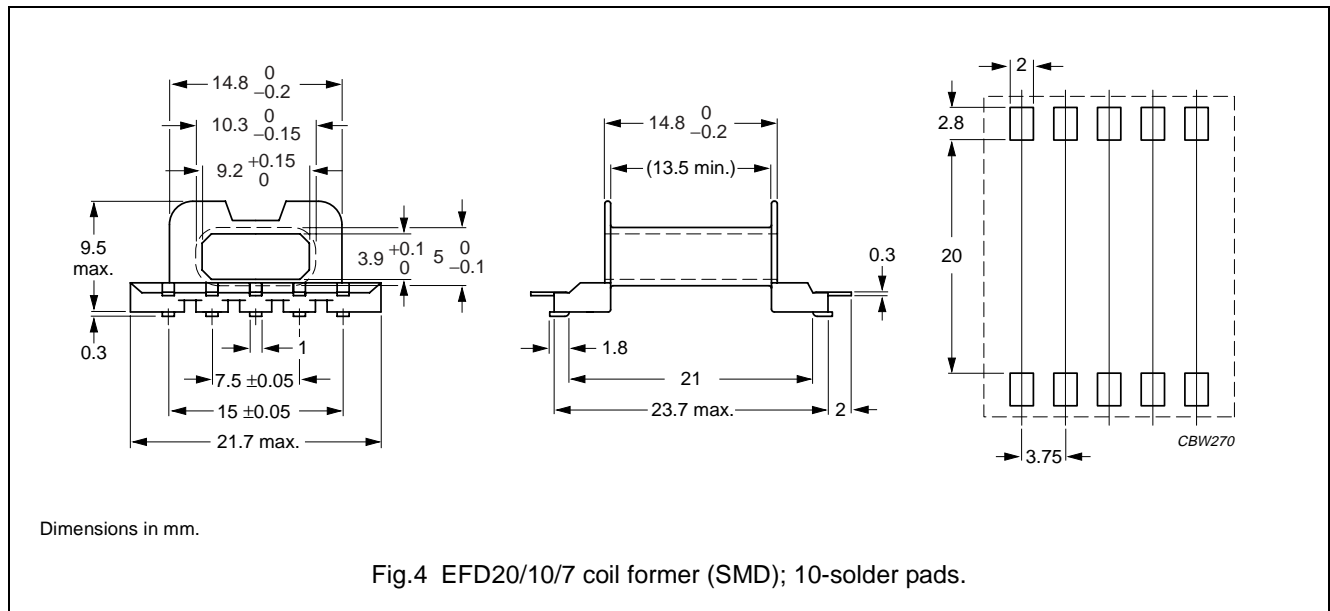

Winding data for EFD20/10/7 coil former (SMD) with 10-solder pads

NUMBER OF SECTIONS	WINDING AREA (mm ²)	MINIMUM WINDING WIDTH (mm)	AVERAGE LENGTH OF TURN (mm)	TYPE NUMBER
1	27.7	13.5	34.1	CPHS-EFD20-1S-10P

COIL FORMERS

General data

PARAMETER	SPECIFICATION
Coil former material	phenolformaldehyde (PF), glass reinforced, flame retardant in accordance with "UL94 V-0"; UL file number E41429 (M)
Solder pad material	copper-tin alloy (CuSn), tin (Sn) plated
Maximum operating temperature	185 °C, "IEC 60085", class H
Resistance to soldering heat	"IEC 60068-2-20", Part 2, Test Tb, method 1B, 350 °C, 3.5 s
Solderability	"IEC 60068-2-20", Part 2, Test Ta, method 1: 235 °C, 2 s

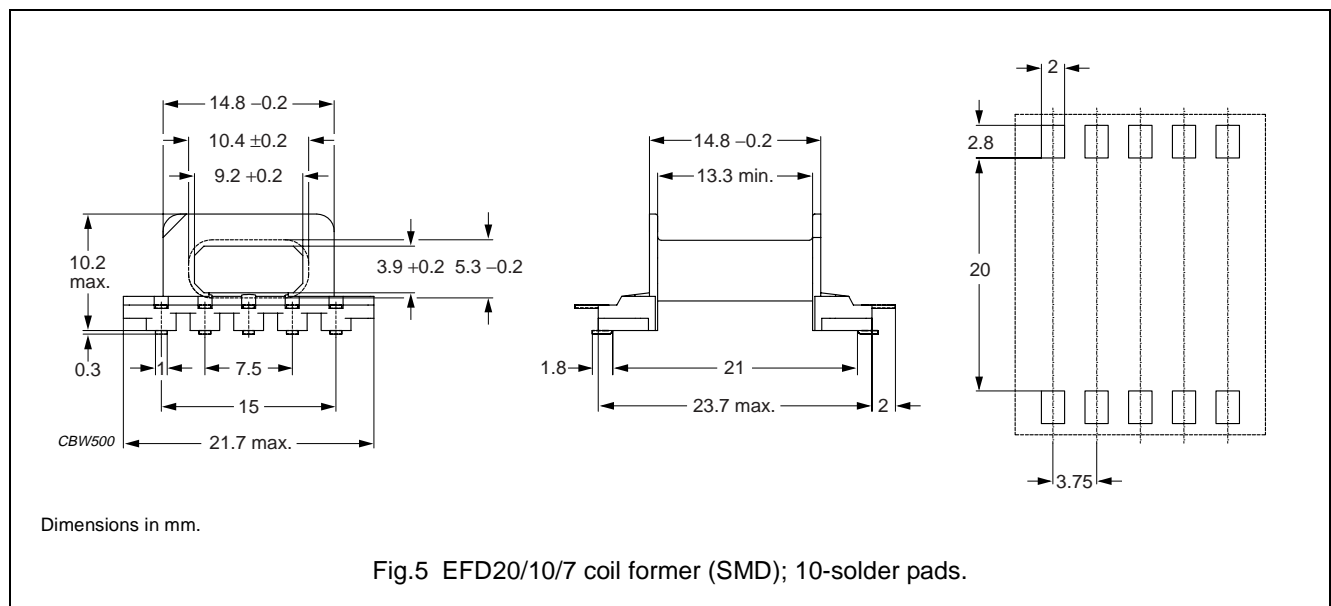

Winding data for EFD20/10/7 coil former (SMD) with 10-solder pads

NUMBER OF SECTIONS	NUMBER OF SOLDER PADS	WINDING AREA (mm ²)	MINIMUM WINDING WIDTH (mm)	AVERAGE LENGTH OF TURN (mm)	TYPE NUMBER
1	10	27.2	13.3	34.9	CSHS-EFD20-1S-10P-Z

MOUNTING PARTS

General data

ITEM	REMARKS	FIGURE	TYPE NUMBER
Clamp	stainless steel (CrNi); clamping force \approx 30 N	6	CLM-EFD20
Clip	stainless steel (CrNi); clamping force \approx 20 N	7	CLI-EFD20

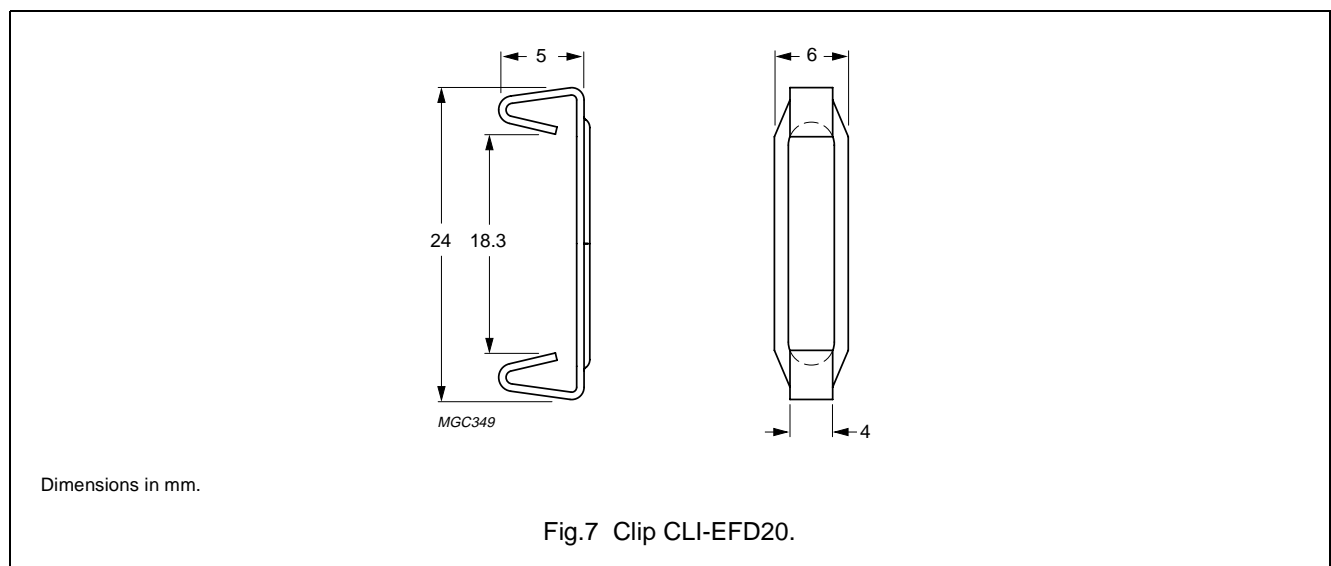
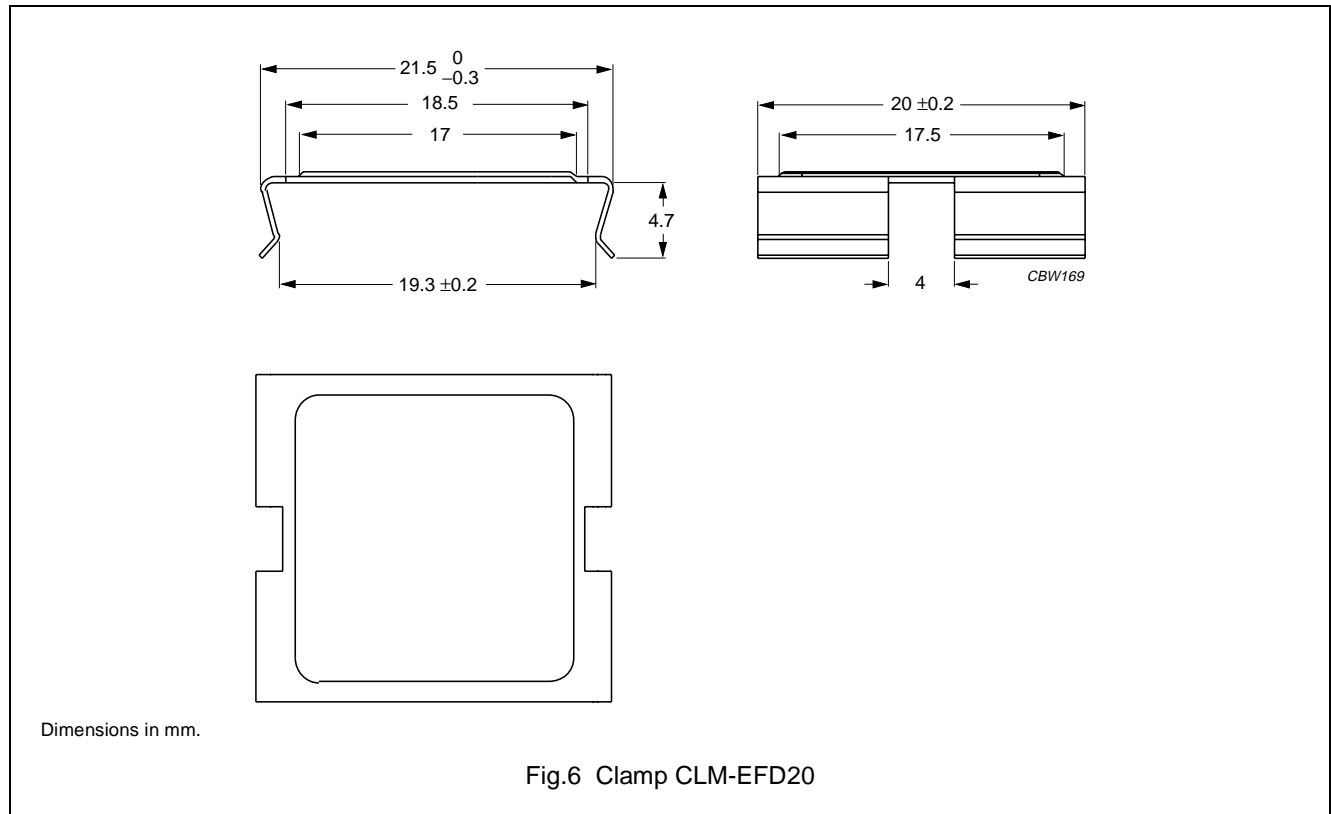



DATA SHEET STATUS DEFINITIONS

DATA SHEET STATUS	PRODUCT STATUS	DEFINITIONS
Preliminary specification	Development	This data sheet contains preliminary data. Ferroxcube reserves the right to make changes at any time without notice in order to improve design and supply the best possible product.
Product specification	Production	This data sheet contains final specifications. Ferroxcube reserves the right to make changes at any time without notice in order to improve design and supply the best possible product.

DISCLAIMER

Life support applications — These products are not designed for use in life support appliances, devices, or systems where malfunction of these products can reasonably be expected to result in personal injury. Ferroxcube customers using or selling these products for use in such applications do so at their own risk and agree to fully indemnify Ferroxcube for any damages resulting from such application.

PRODUCT STATUS DEFINITIONS

STATUS	INDICATION	DEFINITION
Prototype		These are products that have been made as development samples for the purposes of technical evaluation only. The data for these types is provisional and is subject to change.
Design-in		These products are recommended for new designs.
Preferred		These products are recommended for use in current designs and are available via our sales channels.
Support		These products are not recommended for new designs and may not be available through all of our sales channels. Customers are advised to check for availability.