

# DATA SHEET

**EFD15/8/5**

**EFD cores and accessories**

Supersedes data of February 2002

2004 Sep 01

**CORES**

**Effective core parameters**

SYMBOL	PARAMETER	VALUE	UNIT
$\Sigma(l/A)$	core factor (C1)	2.27	mm <sup>-1</sup>
$V_e$	effective volume	510	mm <sup>3</sup>
$l_e$	effective length	34.0	mm
$A_e$	effective area	15.0	mm <sup>2</sup>
$A_{min}$	minimum area	12.2	mm <sup>2</sup>
$m$	mass of core half	≈ 1.4	g

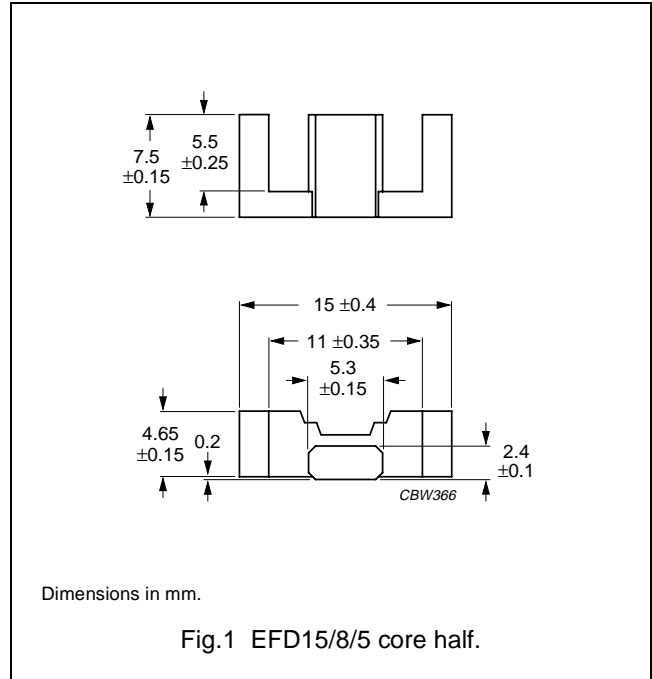

**Core sets**

Clamping force for  $A_L$  measurements, 20 ± 5 N.

GRADE	$A_L$ (nH)	$\mu_e$	AIR GAP ( $\mu$ m)	TYPE NUMBER
3C90	63 ± 5%	≈ 115	≈ 400	EFD15/8/5-3C90-A63-S
	100 ± 8%	≈ 180	≈ 220	EFD15/8/5-3C90-A100-S
	160 ± 10%	≈ 290	≈ 120	EFD15/8/5-3C90-A160-S
	950 ± 25%	≈ 1700	≈ 0	EFD15/8/5-3C90-S
3C94	63 ± 5%	≈ 115	≈ 400	EFD15/8/5-3C94-A63-S
	100 ± 8%	≈ 180	≈ 220	EFD15/8/5-3C94-A100-S
	160 ± 10%	≈ 290	≈ 120	EFD15/8/5-3C94-A160-S
	950 ± 25%	≈ 1700	≈ 0	EFD15/8/5-3C94-S
3C96 <small>des</small>	850 ± 25%	≈ 1520	≈ 0	EFD15/8/5-3C96-S
3F3	63 ± 5%	≈ 115	≈ 400	EFD15/8/5-3F3-A63-S
	100 ± 8%	≈ 180	≈ 220	EFD15/8/5-3F3-A100-S
	160 ± 10%	≈ 290	≈ 120	EFD15/8/5-3F3-A160-S
	780 ± 25%	≈ 1400	≈ 0	EFD15/8/5-3F3-S
3F35 <small>prot</small>	630 ± 25%	≈ 1130	≈ 0	EFD15/8/5-3F35-S
3F4 <small>des</small>	63 ± 5%	≈ 115	≈ 360	EFD15/8/5-3F4-A63-S
	100 ± 8%	≈ 180	≈ 190	EFD15/8/5-3F4-A100-S
	160 ± 10%	≈ 290	≈ 90	EFD15/8/5-3F4-A160-S
	400 ± 25%	≈ 720	≈ 0	EFD15/8/5-3F4-S
3F45 <small>prot</small>	400 ± 25%	≈ 720	≈ 0	EFD15/8/5-3F45-S

## EFD cores and accessories

EFD15/8/5

**Core sets of high permeability grades**Clamping force for  $A_L$  measurements,  $10 \pm 5N$ .

GRADE	$A_L$ (nH)	$\mu_e$	AIR GAP ( $\mu m$ )	TYPE NUMBER
3E5	3600 +40/-30%	$\approx 6500$	$\approx 0$	EFD15/8/5-3E5-S

**Properties of core sets under power conditions**

GRADE	B (mT) at	CORE LOSS (W) at			
	H = 250 A/m; f = 25 kHz; T = 100 °C	f = 100 kHz; $\hat{B} = 100$ mT; T = 100 °C	f = 100 kHz; $\hat{B} = 200$ mT; T = 100 °C	f = 400 kHz; $\hat{B} = 50$ mT; T = 100 °C	f = 500 kHz; $\hat{B} = 50$ mT; T = 100 °C
3C90	$\geq 320$	$\leq 0.057$	–	–	–
3C94	$\geq 320$	$\leq 0.045$	$\leq 0.28$	–	–
3C96	$\geq 340$	$\leq 0.035$	$\leq 0.22$	$\leq 0.09$	$\leq 0.19$
3F35	$\geq 300$	–	–	$\leq 0.05$	$\leq 0.06$
3F3	$\geq 315$	$\leq 0.06$	–	$\leq 0.1$	–
3F4	$\geq 250$	–	–	–	–

**Properties of core sets under power conditions (continued)**

GRADE	B (mT) at	CORE LOSS (W) at			
	H = 250 A/m; f = 25 kHz; T = 100 °C	f = 500 kHz; $\hat{B} = 100$ mT; T = 100 °C	f = 1 MHz; $\hat{B} = 30$ mT; T = 100 °C	f = 1 MHz; $\hat{B} = 50$ mT; T = 100 °C	f = 3 MHz; $\hat{B} = 10$ mT; T = 100 °C
3C90	$\geq 320$	–	–	–	–
3C94	$\geq 320$	–	–	–	–
3C96	$\geq 340$	–	–	–	–
3F35	$\geq 300$	$\leq 0.5$	–	–	–
3F3	$\geq 315$	–	–	–	–
3F4	$\geq 250$	–	$\leq 0.15$	–	$\leq 0.24$
3F45	$\geq 250$	–	$\leq 0.1$	$\leq 0.26$	$\leq 0.18$

**COIL FORMERS**

**General data**

PARAMETER	SPECIFICATION
Coil former material	phenolformaldehyde (PF), glass reinforced, flame retardant in accordance with "UL 94V-0"; UL file number E167521(M)
Pin material	copper-tin alloy (CuSn), Ni flash, tin-lead alloy (SnPb) plated, see note 1
Maximum operating temperature	180 °C, "IEC 60085", class H
Resistance to soldering heat	"IEC 60068-2-20", Part 2, Test Tb, method 1B, 350 °C, 3.5 s
Solderability	"IEC 60068-2-20", Part 2, Test Ta, method 1: 235 °C, 2 s

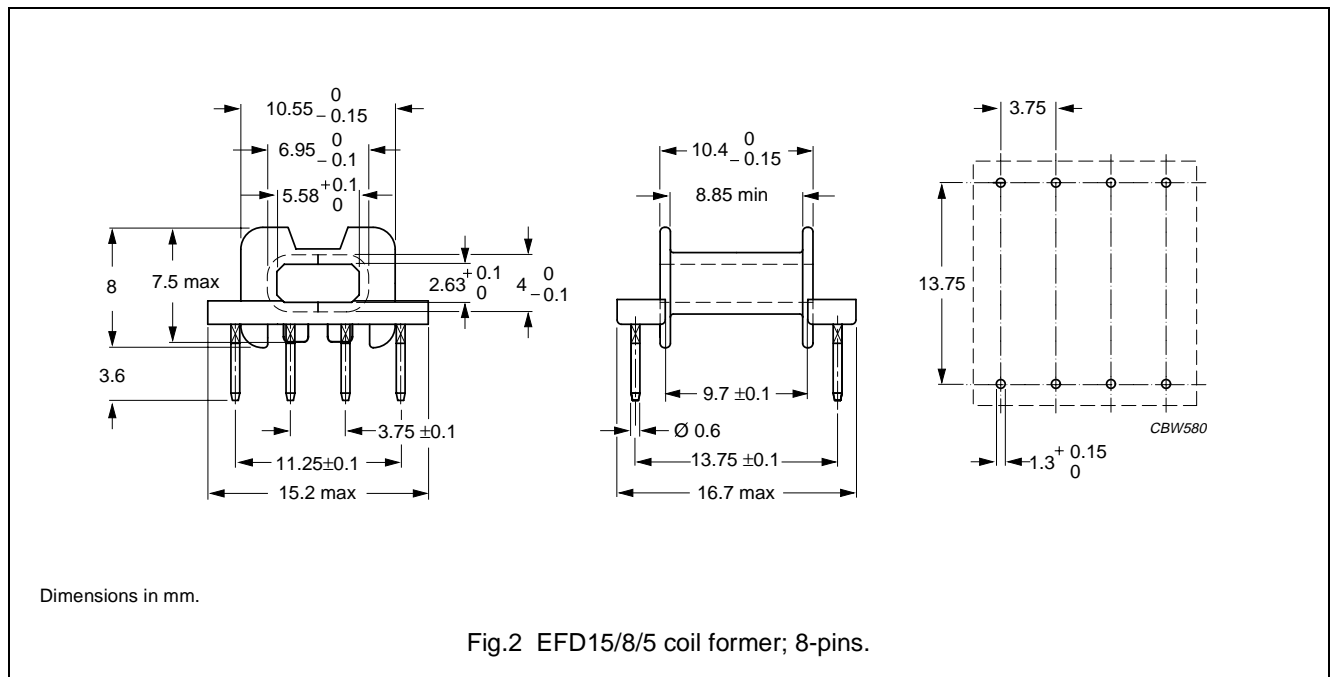

**Winding data for EFD15/8/5 coil former with 8-pins**

NUMBER OF SECTIONS	WINDING AREA (mm <sup>2</sup> )	MINIMUM WINDING WIDTH (mm)	AVERAGE LENGTH OF TURN (mm)	TYPE NUMBER
1	14.8	8.85	26.3	CSH-EFD15-1S-8P; see note 1

**Note**

1. Also available with post-inserted lead-free pins.

**COIL FORMERS**

**General data**

PARAMETER	SPECIFICATION
Coil former material	liquid crystal polymer (LCP), glass reinforced, flame retardant in accordance with "UL 94V-0"; UL file number E54705(M)
Pin material	copper-tin alloy (CuSn), nickel flash, tin (Sn) plated
Maximum operating temperature	155 °C, "IEC 60085", class F
Resistance to soldering heat	"IEC 60068-2-20", Part 2, Test Tb, method 1B, 350 °C, 3.5 s
Solderability	"IEC 60068-2-20", Part 2, Test Ta, method 1: 235 °C, 2 s

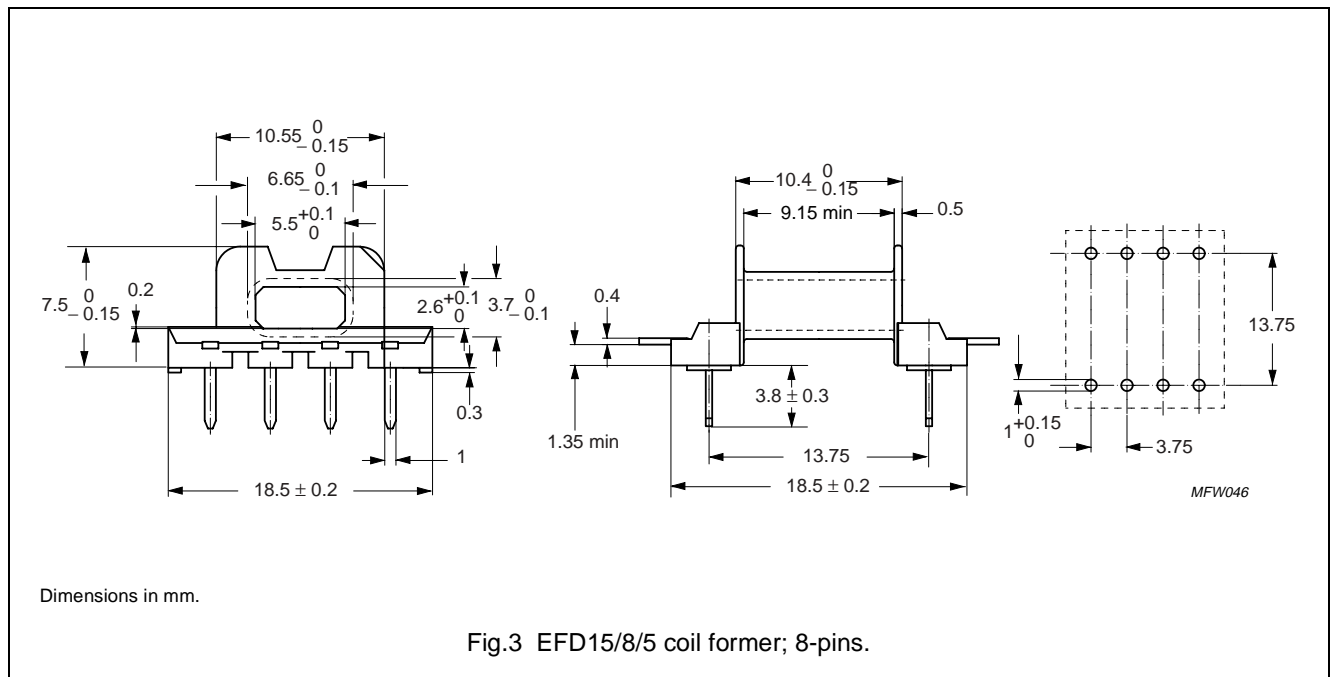

**Winding data for EFD15/8/5 coil former (PCB) with 8-pins**

NUMBER OF SECTIONS	WINDING AREA (mm <sup>2</sup> )	MINIMUM WINDING WIDTH (mm)	AVERAGE LENGTH OF TURN (mm)	TYPE NUMBER
1	16.7	9.15	25.6	CPH-EFD15-1S-8PD-Z

**COIL FORMERS**

**General data**

PARAMETER	SPECIFICATION
Coil former material	liquid crystal polymer (LCP), glass reinforced, flame retardant in accordance with "UL 94V-0"; UL file number E54705 (M)
Solder pad material	copper-tin alloy (CuSn), tin-lead alloy (SnPb) plated, transition to lead-free (Sn) ongoing.
Maximum operating temperature	155 °C, "IEC 60085", class F
Resistance to soldering heat	"IEC 60068-2-20", Part 2, Test Tb, method 1B, 350 °C, 3.5 s
Solderability	"IEC 60068-2-20", Part 2, Test Ta, method 1: 235 °C, 2 s

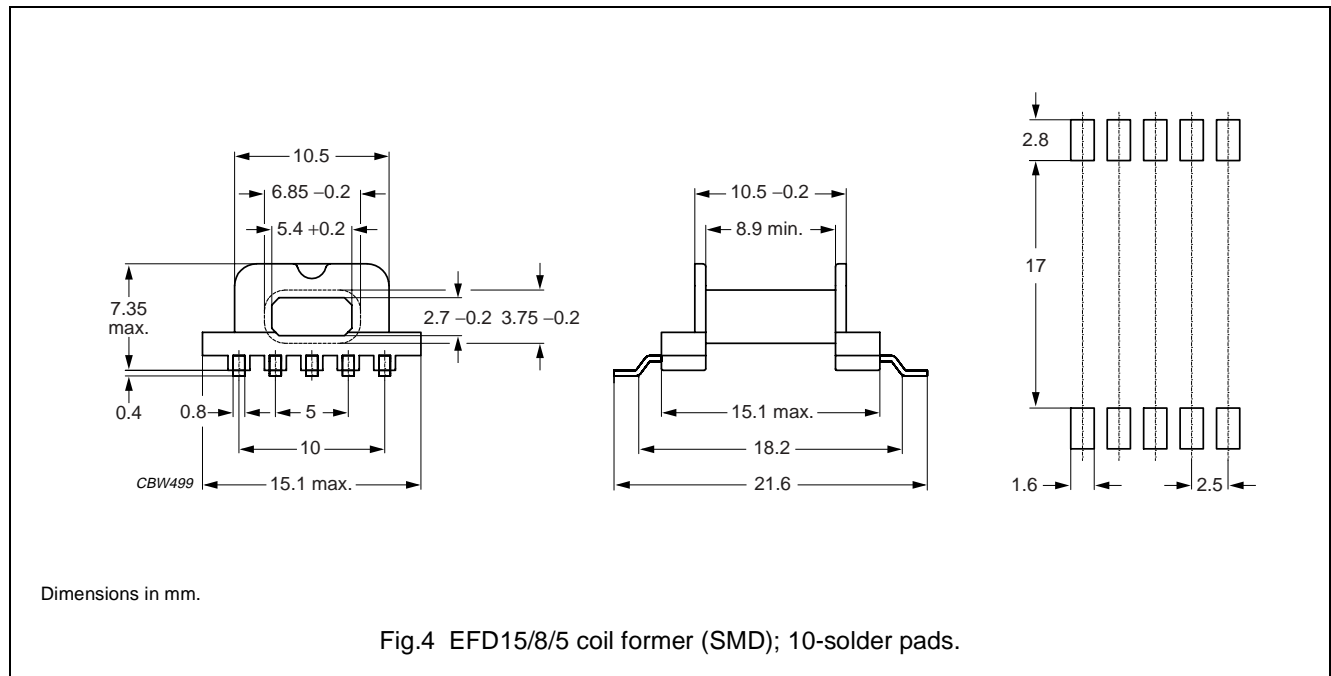

**Winding data for EFD15/8/5 coil former (SMD)**

NUMBER OF SECTIONS	NUMBER OF SOLDER PADS	WINDING AREA (mm <sup>2</sup> )	MINIMUM WINDING WIDTH (mm)	AVERAGE LENGTH OF TURN (mm)	TYPE NUMBER
1	10	16	8.9	26	CPHS-EFD15-1S-10P

**COIL FORMERS**

**General data**

PARAMETER	SPECIFICATION
Coil former material	phenolformaldehyde (PF), glass reinforced, flame retardant in accordance with "UL 94V-0"; UL file number E41429 (M)
Pin material	copper-tin alloy (CuSn), tin (Sn) plated
Maximum operating temperature	180 °C, "IEC 60085", class H
Resistance to soldering heat	"IEC 60068-2-20", Part 2, Test Tb, method 1B, 350 °C, 3.5 s
Solderability	"IEC 60068-2-20", Part 2, Test Ta, method 1: 235 °C, 2 s

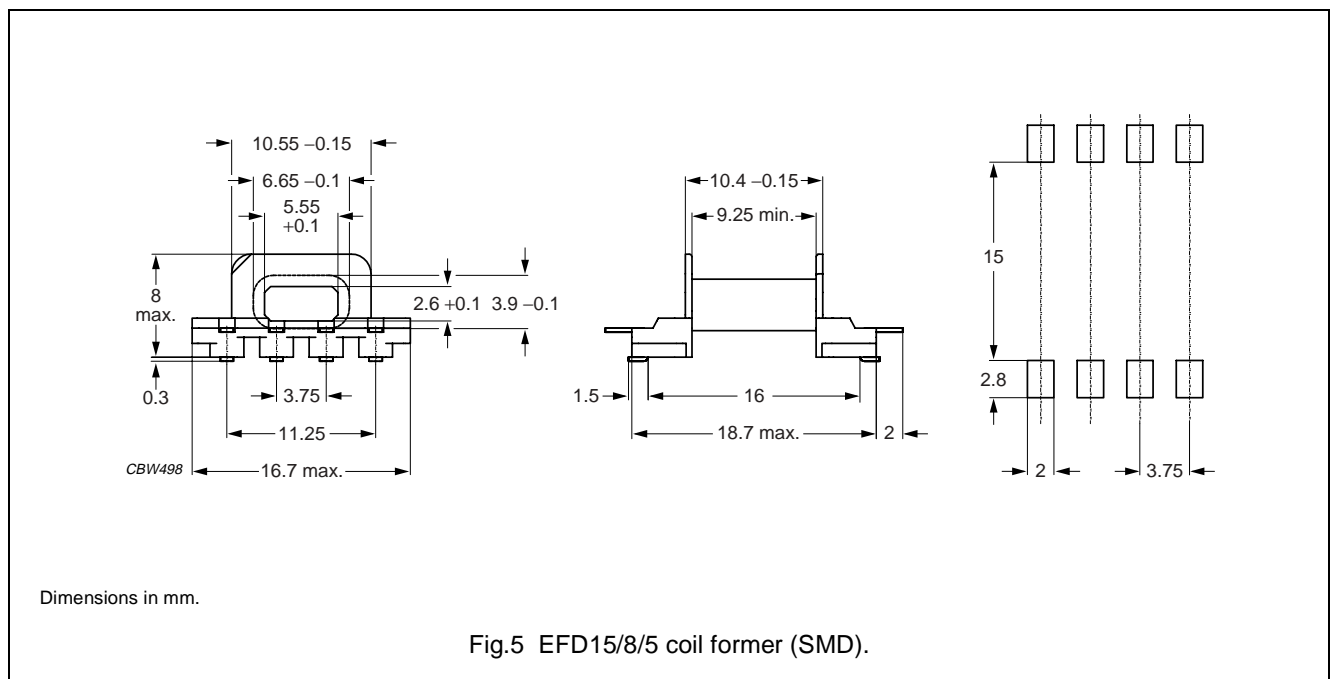

**Winding data for EFD15/8/5 (SMD) coil former**

NUMBER OF SECTIONS	WINDING AREA (mm <sup>2</sup> )	MINIMUM WINDING WIDTH (mm)	AVERAGE LENGTH OF TURN (mm)	TYPE NUMBER
1	16.7	9.25	24.1	CSHS-EFD15-1S-8P-Z

**MOUNTING PARTS**

**General data**

ITEM	REMARKS	FIGURE	TYPE NUMBER
Clamp	stainless steel (CrNi); clamping force $\approx 25$ N	6	CLM-EFD15
Clip	stainless steel (CrNi); clamping force $\approx 12.5$ N	7	CLI-EFD15

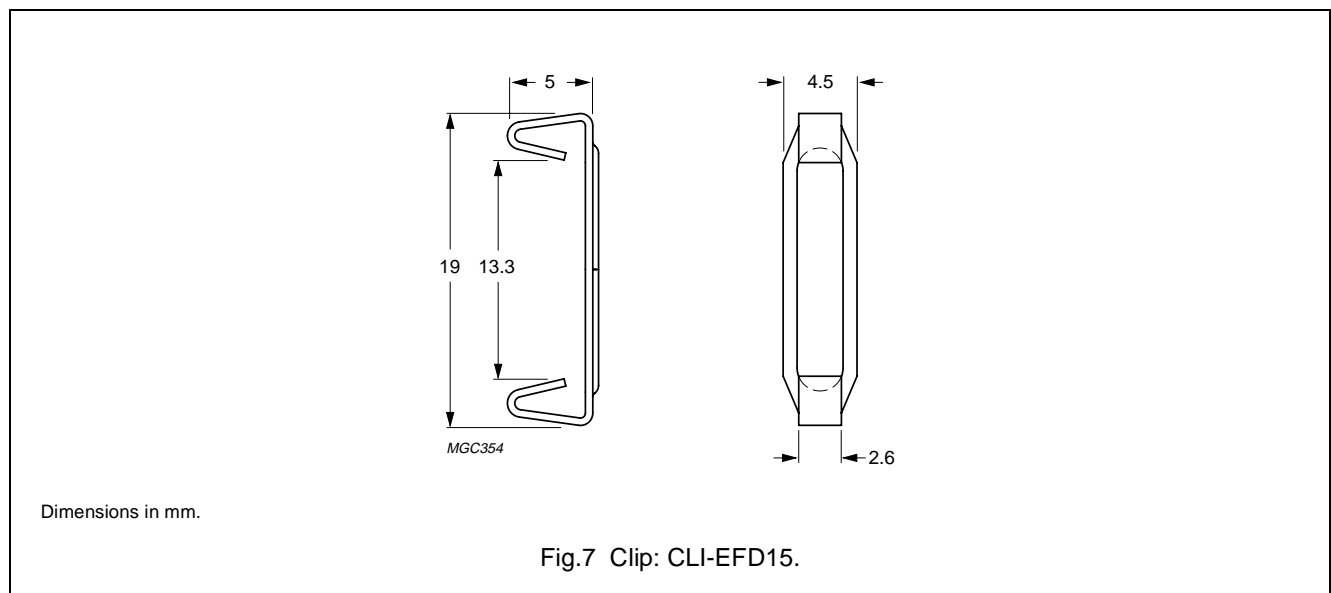
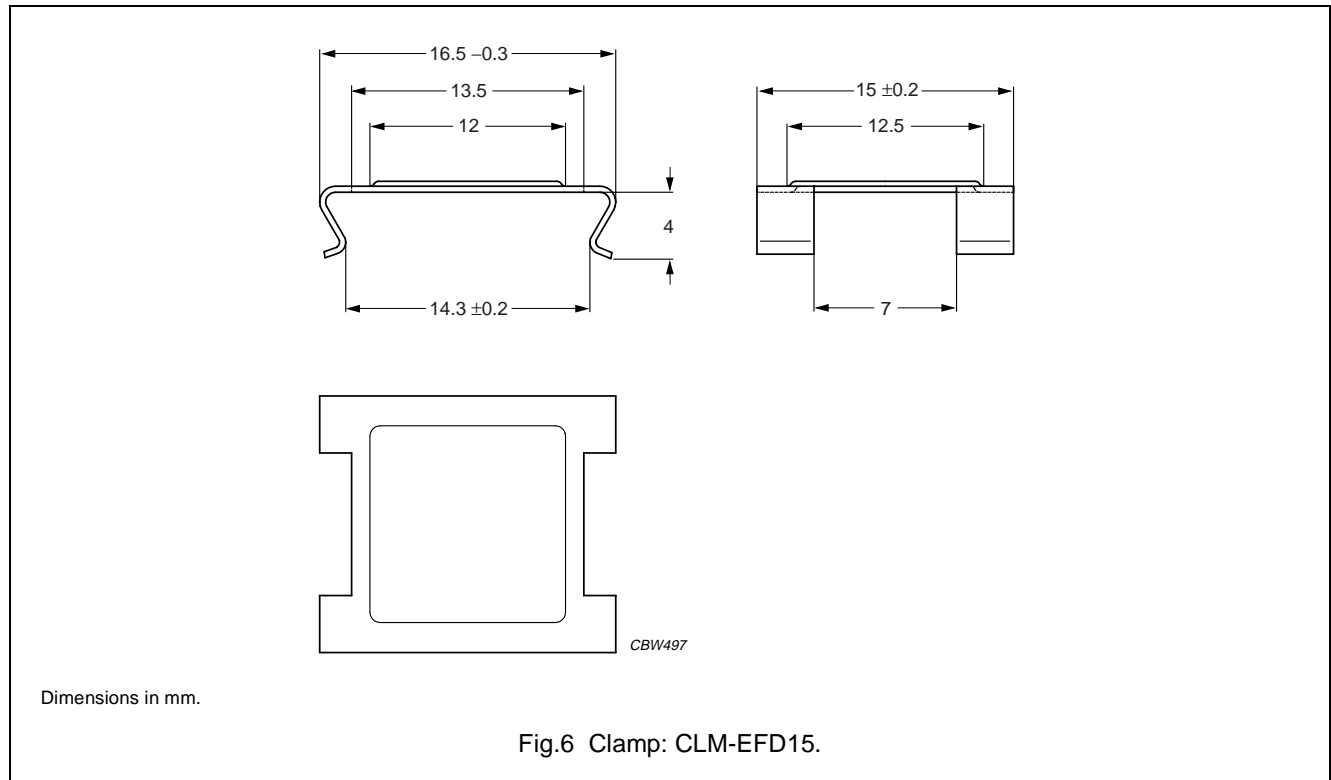



**DATA SHEET STATUS DEFINITIONS**

DATA SHEET STATUS	PRODUCT STATUS	DEFINITIONS
Preliminary specification	Development	This data sheet contains preliminary data. Ferroxcube reserves the right to make changes at any time without notice in order to improve design and supply the best possible product.
Product specification	Production	This data sheet contains final specifications. Ferroxcube reserves the right to make changes at any time without notice in order to improve design and supply the best possible product.

**DISCLAIMER**

**Life support applications** — These products are not designed for use in life support appliances, devices, or systems where malfunction of these products can reasonably be expected to result in personal injury. Ferroxcube customers using or selling these products for use in such applications do so at their own risk and agree to fully indemnify Ferroxcube for any damages resulting from such application.

**PRODUCT STATUS DEFINITIONS**

STATUS	INDICATION	DEFINITION
<b>Prototype</b>		These are products that have been made as development samples for the purposes of technical evaluation only. The data for these types is provisional and is subject to change.
<b>Design-in</b>		These products are recommended for new designs.
<b>Preferred</b>		These products are recommended for use in current designs and are available via our sales channels.
<b>Support</b>		These products are <b>not</b> recommended for new designs and may not be available through all of our sales channels. Customers are advised to check for availability.