

DATA SHEET

E42/21/15

E cores and accessories

Supersedes data of February 2002

2004 Sep 01

CORE SETS

Effective core parameters

SYMBOL	PARAMETER	VALUE	UNIT
$\Sigma(l/A)$	core factor (C1)	0.548	mm ⁻¹
V_e	effective volume	17300	mm ³
l_e	effective length	97.0	mm
A_e	effective area	178	mm ²
A_{min}	minimum area	175	mm ²
m	mass of core half	≈ 44	g

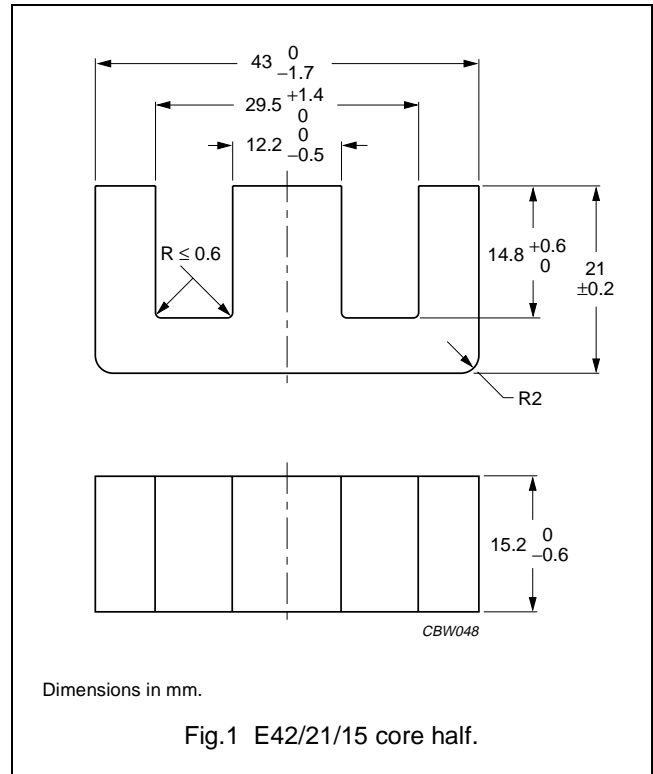

Core halves

A_L measured in combination with a non-gapped core half, clamping force for A_L measurements 40 ± 20 N, unless stated otherwise.

GRADE	A_L (nH)	μ_e	AIR GAP (μ m)	TYPE NUMBER
3C81	100 ±5% ⁽¹⁾	≈ 43	≈ 3960	E42/21/15-3C81-E100
	160 ±5% ⁽¹⁾	≈ 69	≈ 2060	E42/21/15-3C81-E160
	250 ±5% ⁽¹⁾	≈ 108	≈ 1140	E42/21/15-3C81-E250
	315 ±5%	≈ 137	≈ 850	E42/21/15-3C81-A315
	400 ±8%	≈ 173	≈ 630	E42/21/15-3C81-A400
	630 ±15%	≈ 273	≈ 360	E42/21/15-3C81-A630
	5300 ±25%	≈ 2300	≈ 0	E42/21/15-3C81
3C90	100 ±5% ⁽¹⁾	≈ 43	≈ 3960	E42/21/15-3C90-E100
	160 ±5% ⁽¹⁾	≈ 69	≈ 2060	E42/21/15-3C90-E160
	250 ±5% ⁽¹⁾	≈ 108	≈ 1140	E42/21/15-3C90-E250
	315 ±5%	≈ 137	≈ 850	E42/21/15-3C90-A315
	400 ±8%	≈ 173	≈ 630	E42/21/15-3C90-A400
	630 ±15%	≈ 273	≈ 360	E42/21/15-3C90-A630
	3950 ±25%	≈ 1710	≈ 0	E42/21/15-3C90
3C91 <small>des</small>	5300 ±25%	≈ 2300	≈ 0	E42/21/15-3C91
3C92 <small>des</small>	3100 ±25%	≈ 1350	≈ 0	E42/21/15-3C92
3C94	4100 ±25%	≈ 1780	≈ 0	E42/21/15-3C94

E cores and accessories

E42/21/15

GRADE	A _L (nH)	μ _e	AIR GAP (μm)	TYPE NUMBER
3F3	100 ±5% ⁽¹⁾	≈ 43	≈ 3960	E42/21/15-3F3-E100
	160 ±5% ⁽¹⁾	≈ 69	≈ 2060	E42/21/15-3F3-E160
	250 ±5% ⁽¹⁾	≈ 108	≈ 1140	E42/21/15-3F3-E250
	315 ±5%	≈ 137	≈ 850	E42/21/15-3F3-A315
	400 ±8%	≈ 173	≈ 630	E42/21/15-3F3-A400
	630 ±15%	≈ 273	≈ 360	E42/21/15-3F3-A630
	3600 ±25%	≈ 1560	≈ 0	E42/21/15-3F3

Note

1. Measured in combination with an equal gapped core half, clamping force for A_L measurements, 40 ±20 N.

Core halves of high permeability gradesClamping force for A_L measurements 40 ±20 N.

GRADE	A _L (nH)	μ _e	AIR GAP (μm)	TYPE NUMBER
3C11	8000 ±25%	≈ 3470	≈ 0	E42/21/15-3C11
3E27	8000 ±25%	≈ 3470	≈ 0	E42/21/15-3E27

Properties of core sets under power conditions

GRADE	B (mT) at	CORE LOSS (W) at			
	H = 250 A/m; f = 25 kHz; T = 100 °C	f = 25 kHz; B̂ = 200 mT; T = 100 °C	f = 100 kHz; B̂ = 100 mT; T = 100 °C	f = 100 kHz; B̂ = 200 mT; T = 100 °C	f = 400 kHz; B̂ = 50 mT; T = 100 °C
3C81	≥320	≤ 3.6	–	–	–
3C90	≥320	≤ 1.9	≤ 2.2	–	–
3C91	≥320	–	≤ 1.3 ⁽¹⁾	≤ 7.0 ⁽¹⁾	–
3C92	≥370	–	≤ 1.7	≤ 8.8	–
3C94	≥320	–	≤ 1.7	≤ 8.8	–
3F3	≥320	–	≤ 2.2	–	≤ 3.8

Note

1. Measured at 60 °C.

COIL FORMERS

General data for E42/21/15 coil former without pins

PARAMETER	SPECIFICATION
Coil former material	polybutyleneterephthalate (PBT), glass reinforced, flame retardant in accordance with "UL 94V-0"; UL file number E45329(R)
Maximum operating temperature	155 °C, "IEC 60085", class F

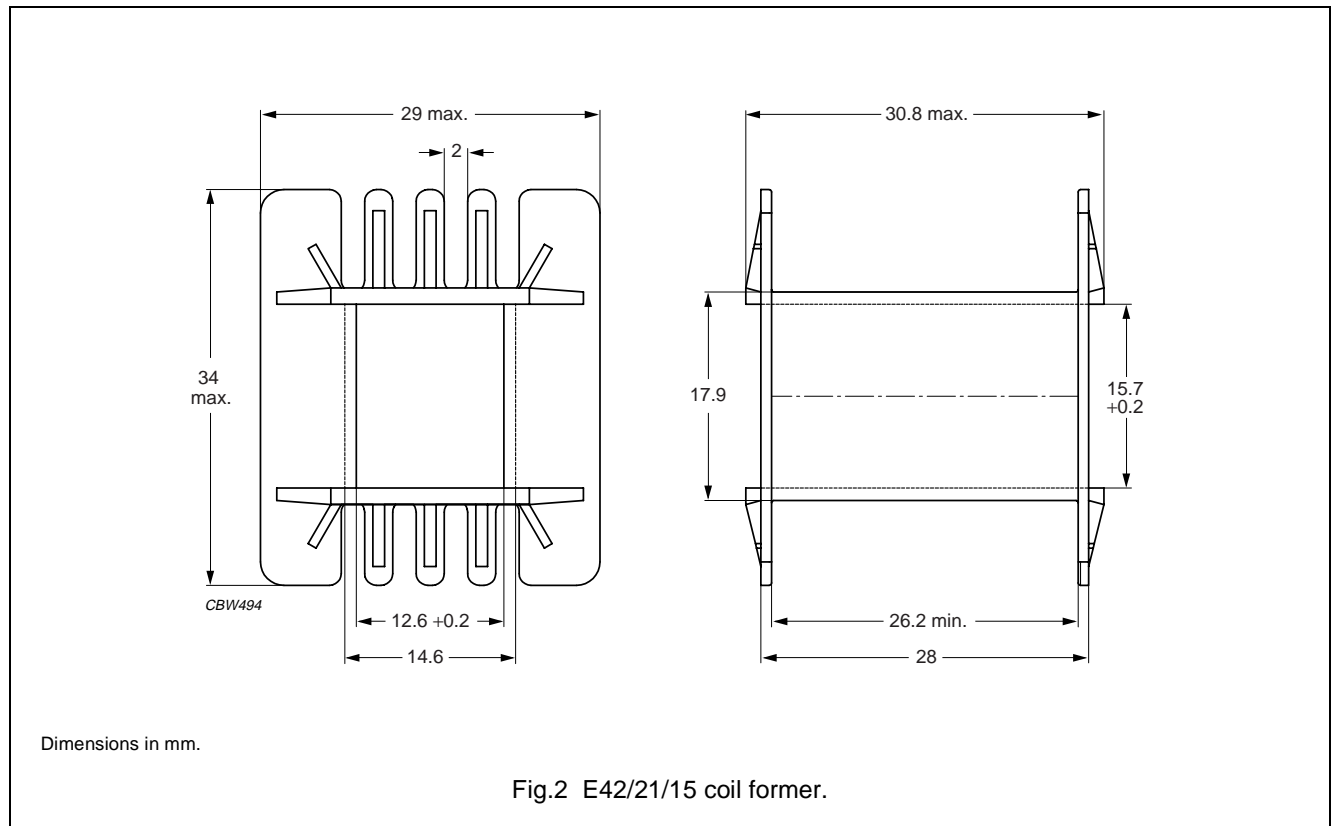

Winding data for E42/21/15 coil former without pins

NUMBER OF SECTIONS	WINDING AREA (mm ²)	MINIMUM WINDING WIDTH (mm)	AVERAGE LENGTH OF TURN (mm)	TYPE NUMBER
1	178	26.2	93	CP-E42/21/15-1S

E cores and accessories

E42/21/15

General data for 10-pins E42/21/15 coil former

PARAMETER	SPECIFICATION
Coil former material	polyamide (PA6.6), glass reinforced, flame retardant in accordance with "UL 94-HB"; UL file number E41871(M)
Pin material	copper-tin alloy (CuSn), tin-lead alloy (SnPb) plated, transition to lead-free (Sn) ongoing.
Maximum operating temperature	120 °C, "IEC 60085", class E
Resistance to soldering heat	"IEC 60068-2-20", Part 2, Test Tb, method 1B: 350 °C, 3.5 s
Solderability	"IEC 60068-2-20", Part 2, Test Ta, method 1: 235 °C, 2 s

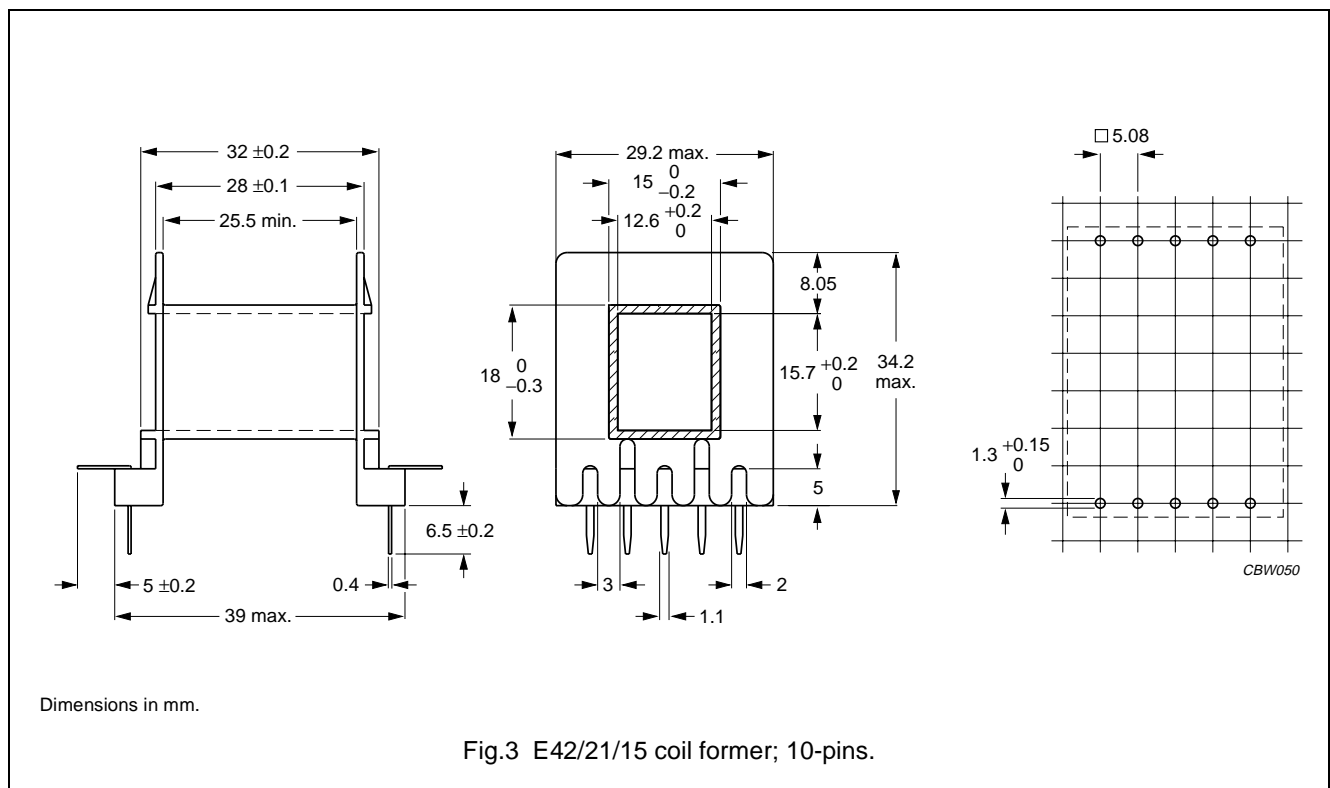

Winding data for 10-pins E42/21/15 coil former

NUMBER OF SECTIONS	WINDING AREA (mm ²)	MINIMUM WINDING WIDTH (mm)	AVERAGE LENGTH OF TURN (mm)	TYPE NUMBER
1	178	25.5	93	CPH-E42/21/15-1S-10P

General data for 10-pins E42/21/15 coil former (A)

PARAMETER	SPECIFICATION
Coil former material	polyamide (PA6.6), glass reinforced, flame retardant in accordance with "UL 94-HB"; UL file number E41938(M)
Pin material	copper-tin alloy (CuSn), tin-lead alloy (SnPb) plated, transition to lead-free (Sn) ongoing.
Maximum operating temperature	105 °C, "IEC 60085", class A
Resistance to soldering heat	"IEC 60068-2-20", Part 2, Test Tb, method 1B: 350 °C, 3.5 s
Solderability	"IEC 60068-2-20", Part 2, Test Ta, method 1: 235 °C, 2 s

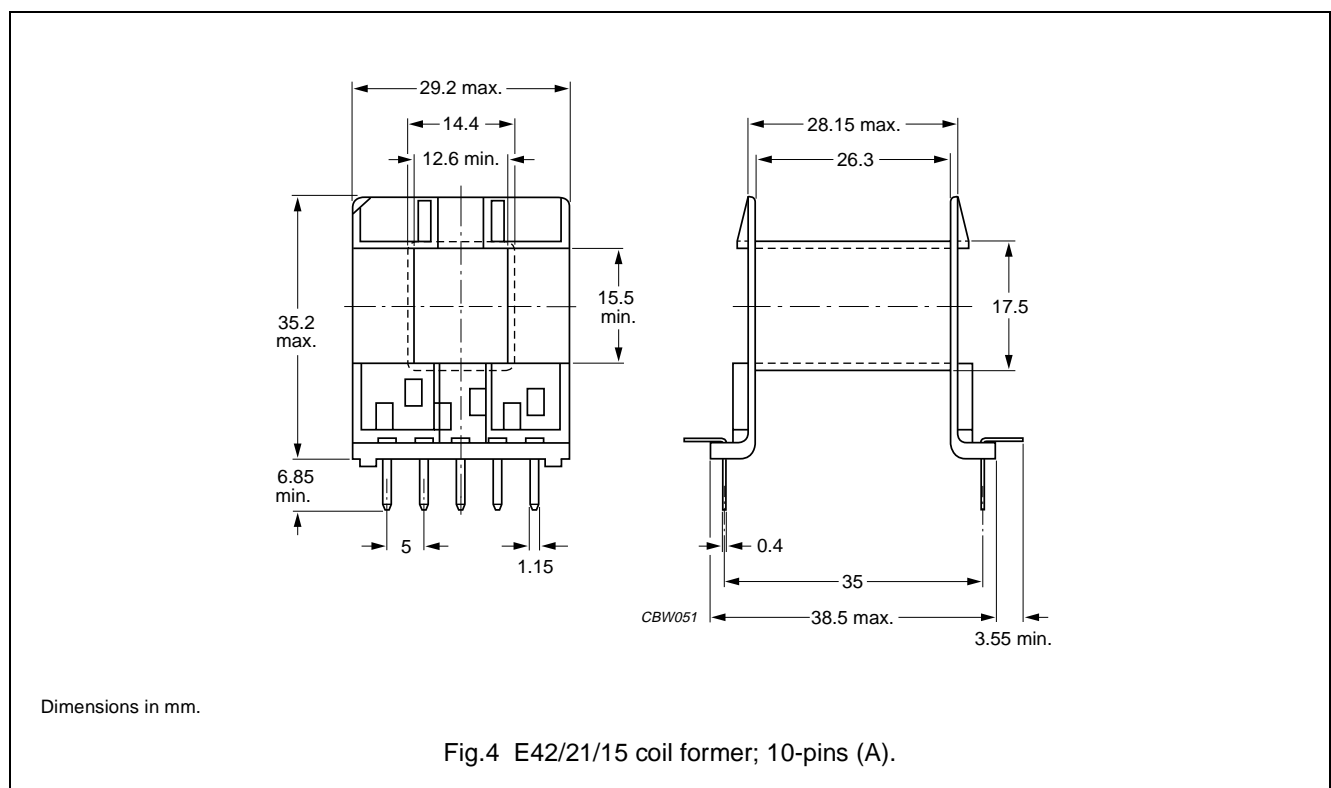

Winding data for 10-pins E42/21/15 coil former

NUMBER OF SECTIONS	MINIMUM WINDING AREA (mm ²)	NOMINAL WINDING WIDTH (mm)	AVERAGE LENGTH OF TURN (mm)	TYPE NUMBER
1	180	26.3	87	CPH-E42/15-1S-10PD-A

MOUNTING PARTS

General data for mounting parts

ITEM	REMARKS	FIGURE	TYPE NUMBER
Clasp	steel, zinc (Zn) plated	5	CLA-E42/21/15
Spring	steel, zinc (Zn) plated	6	SPR-E42/21/15

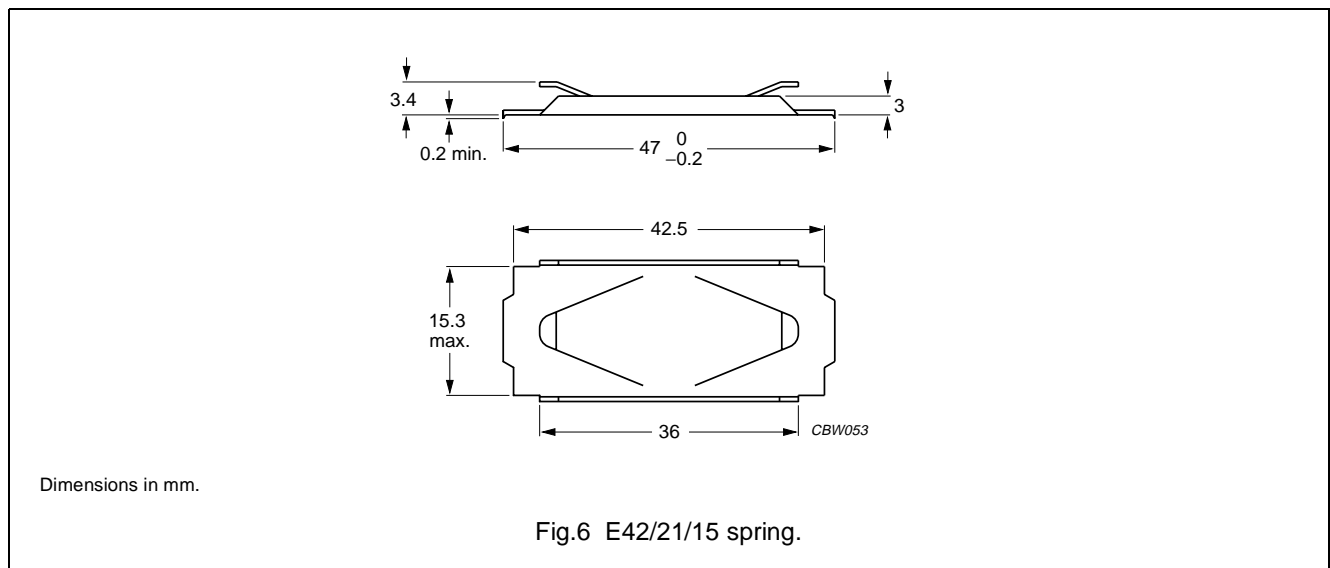
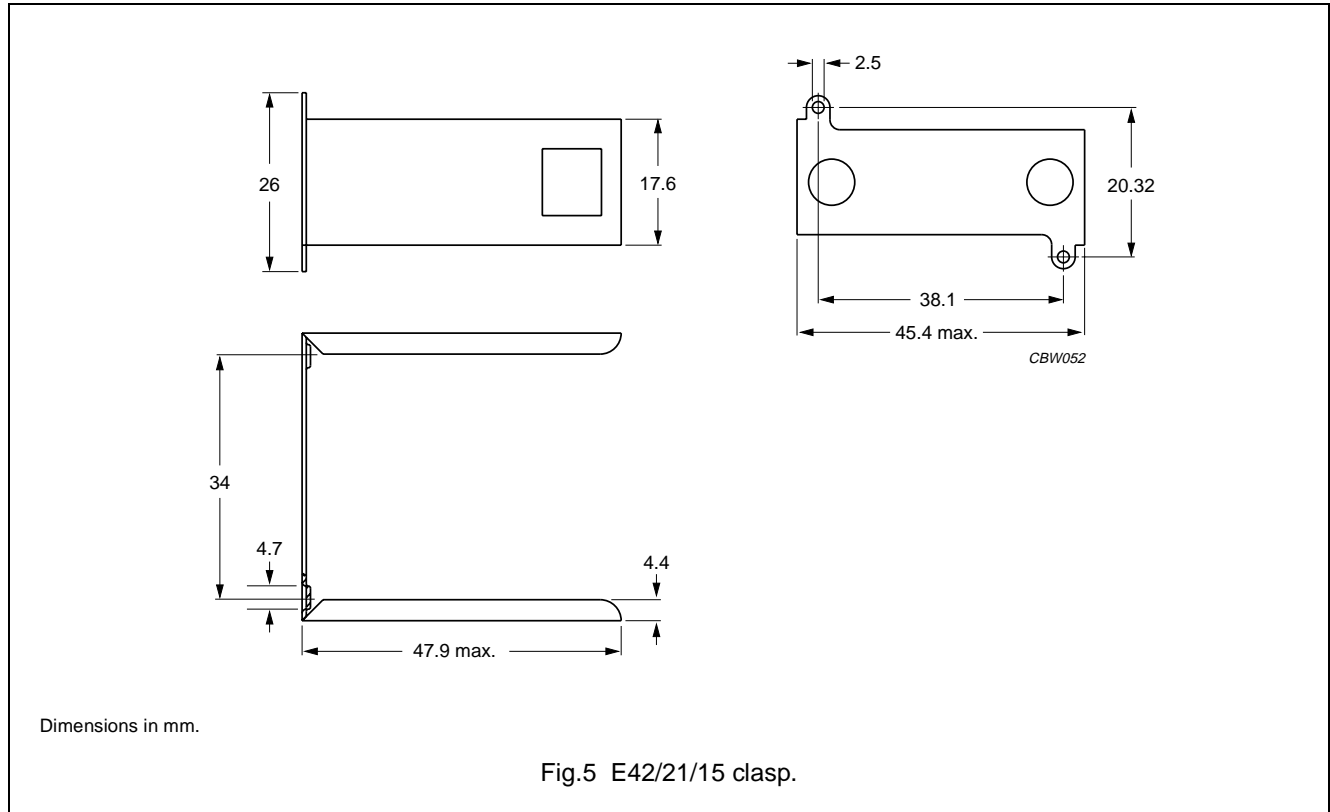



DATA SHEET STATUS DEFINITIONS

DATA SHEET STATUS	PRODUCT STATUS	DEFINITIONS
Preliminary specification	Development	This data sheet contains preliminary data. Ferroxcube reserves the right to make changes at any time without notice in order to improve design and supply the best possible product.
Product specification	Production	This data sheet contains final specifications. Ferroxcube reserves the right to make changes at any time without notice in order to improve design and supply the best possible product.

DISCLAIMER

Life support applications — These products are not designed for use in life support appliances, devices, or systems where malfunction of these products can reasonably be expected to result in personal injury. Ferroxcube customers using or selling these products for use in such applications do so at their own risk and agree to fully indemnify Ferroxcube for any damages resulting from such application.

PRODUCT STATUS DEFINITIONS

STATUS	INDICATION	DEFINITION
Prototype		These are products that have been made as development samples for the purposes of technical evaluation only. The data for these types is provisional and is subject to change.
Design-in		These products are recommended for new designs.
Preferred		These products are recommended for use in current designs and are available via our sales channels.
Support		These products are not recommended for new designs and may not be available through all of our sales channels. Customers are advised to check for availability.