

Motion SPM® 2 Series

Features

- UL Certified No. E209204
- 600 V-20 A 3-Phase IGBT Inverter Bridge Including Control ICs for Gate Driving and Protection
- Three Separate Negative DC-Link Terminals for Inverter Current Sensing Applications
- Single-Grounded Power Supply Thanks to Built-in HVIC
- Typical Switching Frequency of 5 kHz
- Built-in Thermistor for Temperature Monitoring
- Inverter Power Rating of 0.8 kW / 100~253 VAC
- Isolation Rating of 2500 Vrms / min.
- Very Low Leakage Current by Using Ceramic Substrate
- Adjustable Current Protection Level by Changing the Value of Series Resistor Connected to the Emitters of Sense-IGBTs

General Description

FSAM20SM60A is a Motion SPM 2 Series that Fairchild has Developed to Provide a Very Compact and Low Cost, yet High Performance Inverter Solution for AC Motor Drive in Low-Power Applications such as Air Conditioners. It Combines Optimized Circuit Protection and Drive Matched to Low-Loss IGBTs. Effective Over-Current Protection is Realized Through Advanced Current Sensing IGBTs. The System Reliability is Further Enhanced by the Built-in Thermistor and Integrated Under-Voltage Protection. In Addition the Incorporated HVIC Facilitates the use of Single-Supply Voltage without any Negative Bias. Inverter Leg Current Sensing can be Implemented Because of Three Separate Negative DC Terminals.

Applications

- Motion Control - Home Appliance / Industrial Motor

Related Source

- [AN-9043 : Motion SPM® 2 Series User's Guide](#)

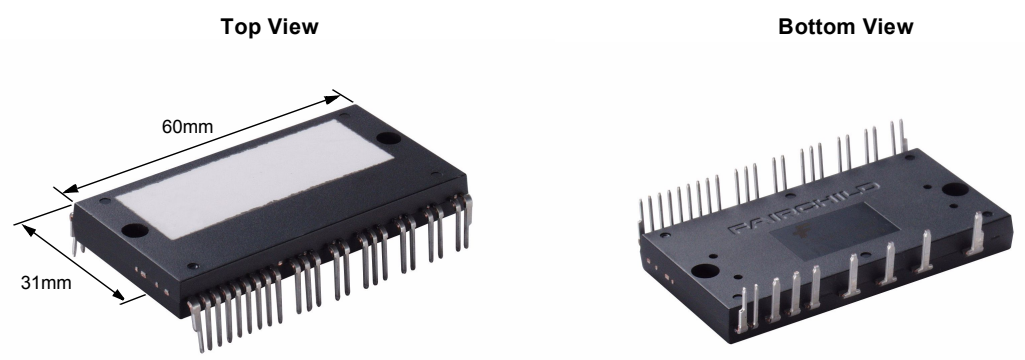

Fig. 1.

Package Marking and Ordering Information

Device Marking	Device	Package	Real Size	Packing Type	Quantity
FSAM20SM60A	FSAM20SM60A	S32AA-32	-	RAIL	8

Integrated Power Functions

- 600 V-20 A IGBT inverter for 3-phase DC / AC power conversion (Please refer to Fig. 3)

Integrated Drive, Protection and System Control Functions

- For inverter high-side IGBTs: Gate drive circuit, High voltage isolated high-speed level shifting
Control circuit under-voltage (UV) protection
Note) Available bootstrap circuit example is given in Figs. 14 and 15.
- For inverter low-side IGBTs: Gate drive circuit, Short-Circuit (SC) protection
Control supply circuit under-voltage (UV) protection
- Temperature Monitoring: System over-temperature monitoring using built-in thermistor
Note) Available temperature monitoring circuit is given in Fig. 15.
- Fault signaling: Corresponding to a SC fault (Low-side IGBTs) or a UV fault (Low-side control supply circuit)
- Input interface: Active-low interface, can work with 3.3 / 5 V Logic

Pin Configuration

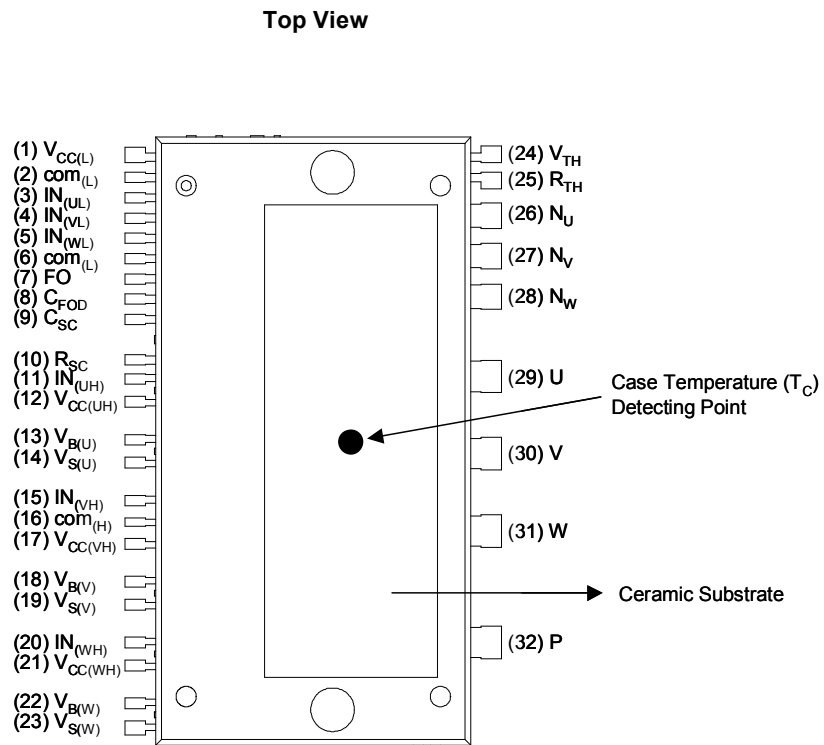

Fig. 2.

Pin Descriptions

Pin Number	Pin Name	Pin Description
1	$V_{CC(L)}$	Low-side Common Bias Voltage for IC and IGBTs Driving
2	$COM_{(L)}$	Low-side Common Supply Ground
3	$IN_{(UL)}$	Signal Input for Low-side U Phase
4	$IN_{(VL)}$	Signal Input for Low-side V Phase
5	$IN_{(WL)}$	Signal Input for Low-side W Phase
6	$COM_{(L)}$	Low-side Common Supply Ground
7	V_{FO}	Fault Output
8	C_{FOD}	Capacitor for Fault Output Duration Time Selection
9	C_{SC}	Capacitor (Low-pass Filter) for Short-Circuit Current Detection Input
10	R_{SC}	Resistor for Short-Circuit Current Detection
11	$IN_{(UH)}$	Signal Input for High-side U Phase
12	$V_{CC(UH)}$	High-side Bias Voltage for U Phase IC
13	$V_{B(U)}$	High-side Bias Voltage for U Phase IGBT Driving
14	$V_{S(U)}$	High-side Bias Voltage Ground for U Phase IGBT Driving
15	$IN_{(VH)}$	Signal Input for High-side V Phase
16	$COM_{(H)}$	High-side Common Supply Ground
17	$V_{CC(VH)}$	High-side Bias Voltage for V Phase IC
18	$V_{B(V)}$	High-side Bias Voltage for V Phase IGBT Driving
19	$V_{S(V)}$	High-side Bias Voltage Ground for V Phase IGBT Driving
20	$IN_{(WH)}$	Signal Input for High-side W Phase
21	$V_{CC(WH)}$	High-side Bias Voltage for W Phase IC
22	$V_{B(W)}$	High-side Bias Voltage for W Phase IGBT Driving
23	$V_{S(W)}$	High-side Bias Voltage Ground for W Phase IGBT Driving
24	V_{TH}	Thermistor Bias Voltage
25	R_{TH}	Series Resistor for the Use of Thermistor (Temperature Detection)
26	N_U	Negative DC-Link Input for U Phase
27	N_V	Negative DC-Link Input for V Phase
28	N_W	Negative DC-Link Input for W Phase
29	U	Output for U Phase
30	V	Output for V Phase
31	W	Output for W Phase
32	P	Positive DC-Link Input

Internal Equivalent Circuit and Input/Output Pins

Bottom View

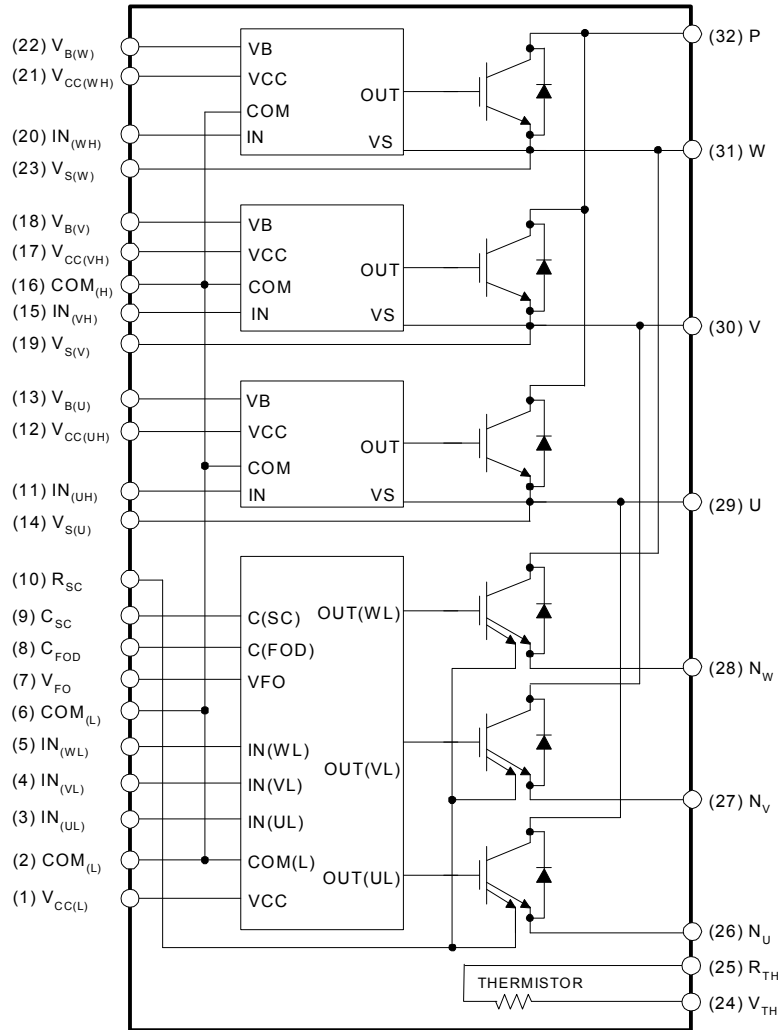

Note:

- 1) Inverter low-side is composed of three sense-IGBTs including freewheeling diodes for each IGBT and one control IC which has gate driving, current sensing and protection functions.
- 2) Inverter power side is composed of four inverter dc-link input pins and three inverter output pins.
- 3) Inverter high-side is composed of three normal-IGBTs including freewheeling diodes and three drive ICs for each IGBT.

Fig. 3.

Absolute Maximum Ratings ($T_J = 25^\circ\text{C}$, Unless Otherwise Specified)

Inverter Part

Item	Symbol	Condition	Rating	Unit
Supply Voltage	V_{PN}	Applied between P- N_U, N_V, N_W	450	V
Supply Voltage (Surge)	$V_{PN(\text{Surge})}$	Applied between P- N_U, N_V, N_W	500	V
Collector-Emitter Voltage	V_{CES}		600	V
Each IGBT Collector Current	$\pm I_C$	$T_C = 25^\circ\text{C}$	20	A
Each IGBT Collector Current	$\pm I_C$	$T_C = 100^\circ\text{C}$	15	A
Each IGBT Collector Current (Peak)	$\pm I_{CP}$	$T_C = 25^\circ\text{C}$, Instantaneous Value (Pulse)	40	A
Collector Dissipation	P_C	$T_C = 25^\circ\text{C}$ per One Chip	59	W
Operating Junction Temperature	T_J	(Note 1)	-20 ~ 125	$^\circ\text{C}$

Note:

1. It would be recommended that the average junction temperature should be limited to $T_J \leq 125^\circ\text{C}$ ($@T_C \leq 100^\circ\text{C}$) in order to guarantee safe operation.

Control Part

Item	Symbol	Condition	Rating	Unit
Control Supply Voltage	V_{CC}	Applied between $V_{CC(UH)}, V_{CC(VH)}, V_{CC(WH)} - \text{COM}_{(H)}$, $V_{CC(L)} - \text{COM}_{(L)}$	20	V
High-side Control Bias Voltage	V_{BS}	Applied between $V_{B(U)} - V_{S(U)}, V_{B(V)} - V_{S(V)}, V_{B(W)} - V_{S(W)}$	20	V
Input Signal Voltage	V_{IN}	Applied between $IN_{(UH)}, IN_{(VH)}, IN_{(WH)} - \text{COM}_{(H)}$ $IN_{(UL)}, IN_{(VL)}, IN_{(WL)} - \text{COM}_{(L)}$	-0.3 ~ $V_{CC} + 0.3$	V
Fault Output Supply Voltage	V_{FO}	Applied between $V_{FO} - \text{COM}_{(L)}$	-0.3 ~ $V_{CC} + 0.3$	V
Fault Output Current	I_{FO}	Sink Current at V_{FO} Pin	5	mA
Current Sensing Input Voltage	V_{SC}	Applied between $C_{SC} - \text{COM}_{(L)}$	-0.3 ~ $V_{CC} + 0.3$	V

Total System

Item	Symbol	Condition	Rating	Unit
Self Protection Supply Voltage Limit (Short-Circuit Protection Capability)	$V_{PN(\text{PROT})}$	$V_{CC} = V_{BS} = 13.5 \sim 16.5 \text{ V}$ $T_J = 125^\circ\text{C}$, Non-repetitive, less than 6 μs	400	V
Module Case Operation Temperature	T_C	Note Fig.2	-20 ~ 100	$^\circ\text{C}$
Storage Temperature	T_{STG}		-20 ~ 125	$^\circ\text{C}$
Isolation Voltage	V_{ISO}	60 Hz, Sinusoidal, AC 1 minute, Connection Pins to Heat-sink Plate	2500	V_{rms}

Absolute Maximum Ratings

Thermal Resistance

Item	Symbol	Condition	Min.	Typ.	Max.	Unit
Junction to Case Thermal Resistance	$R_{th(j-c)Q}$	Each IGBT under Inverter Operating Condition	-	-	2.1	°C/W
	$R_{th(j-c)F}$	Each FWDi under Inverter Operating Condition	-	-	3.3	°C/W
Contact Thermal Resistance	$R_{th(c-f)}$	Ceramic Substrate (per 1 Module) Thermal Grease Applied (Note 3)	-	-	0.06	°C/W

Note:

- For the measurement point of case temperature(T_C), please refer to Fig. 2.
- The thickness of thermal grease should not be more than 100um.

Electrical Characteristics

Inverter Part

Item	Symbol	Condition	Min.	Typ.	Max.	Unit	
Collector - Emitter Saturation Voltage	$V_{CE(SAT)}$	$V_{CC} = V_{BS} = 15\text{ V}$ $V_{IN} = 0\text{ V}$	$I_C = 20\text{ A}, T_J = 25^\circ\text{C}$	-	-	2.3	V
			$I_C = 20\text{ A}, T_J = 125^\circ\text{C}$	-	-	2.4	V
FWDi Forward Voltage	V_{FM}	$V_{IN} = 5\text{ V}$	$I_C = 20\text{ A}, T_J = 25^\circ\text{C}$	-	-	2.5	V
			$I_C = 20\text{ A}, T_J = 125^\circ\text{C}$	-	-	2.3	V
Switching Times	t_{ON}	$V_{PN} = 300\text{ V}, V_{CC} = V_{BS} = 15\text{ V}$ $I_C = 20\text{ A}, T_J = 25^\circ\text{C}$ $V_{IN} = 5\text{ V} \leftrightarrow 0\text{ V}$, Inductive Load (High, Low-side)		-	0.35	-	us
	$t_{C(ON)}$			-	0.16	-	us
	t_{OFF}			-	0.88	-	us
	$t_{C(OFF)}$			-	0.35	-	us
	t_{rr}		(Note 4)	-	0.13	-	us
Collector - Emitter Leakage Current	I_{CES}	$V_{CE} = V_{CES}, T_J = 25^\circ\text{C}$	-	-	250	μA	

Note:

- t_{ON} and t_{OFF} include the propagation delay time of the internal drive IC. $t_{C(ON)}$ and $t_{C(OFF)}$ are the switching time of IGBT itself under the given gate driving condition internally. For the detailed information, please see Fig. 4.

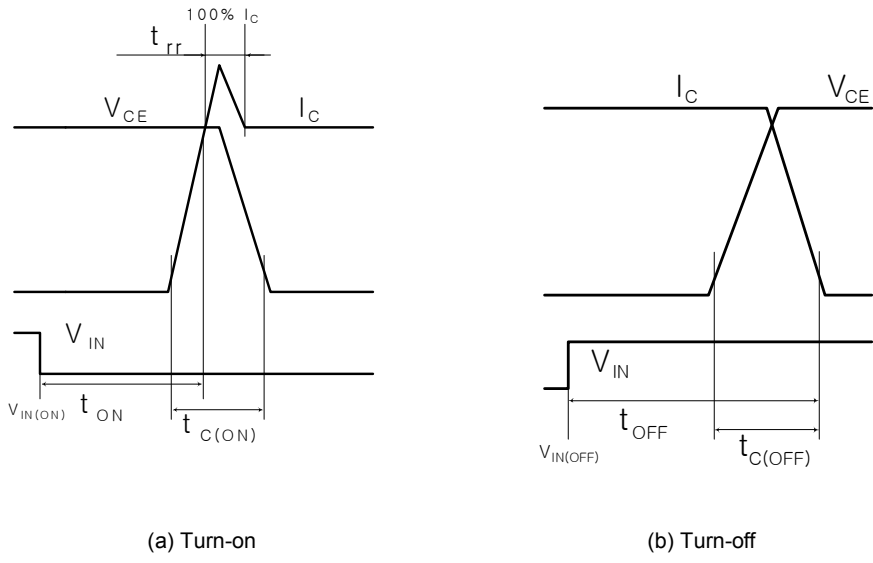

Fig. 4. Switching Time Definition

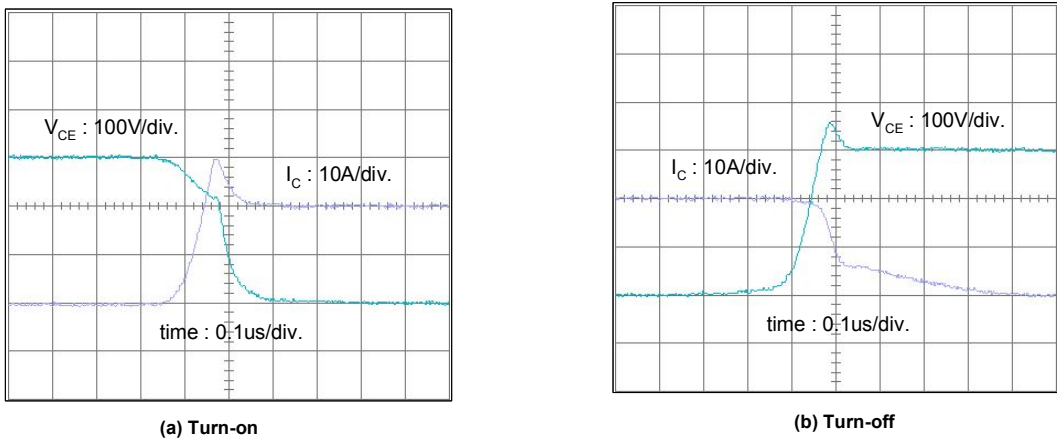

Fig. 5. Experimental Results of Switching Waveforms
 Test Condition: $V_{dc} = 300\text{ V}$, $V_{cc} = 15\text{ V}$, $L = 500\text{ uH}$ (Inductive Load), $T_j = 25^\circ\text{C}$

Electrical Characteristics ($T_J = 25^\circ\text{C}$, Unless Otherwise Specified)

Control Part

Item	Symbol	Condition	Min.	Typ.	Max.	Unit
Control Supply Voltage	V_{CC}	Applied between $V_{CC(UH)}$, $V_{CC(VH)}$, $V_{CC(WH)}$, $V_{CC(L)}$ - COM	13.5	15	16.5	V
High-side Bias Voltage	V_{BS}	Applied between $V_{B(U)}$ - $V_{S(U)}$, $V_{B(V)}$ - $V_{S(V)}$, $V_{B(W)}$ - $V_{S(W)}$	13.5	15	16.5	V
Quiescent V_{CC} Supply Current	I_{QCCL}	$V_{CC} = 15\text{ V}$ $I_{N(UH, VL, WL)} = 5\text{ V}$			26	mA
	I_{QCCH}	$V_{CC} = 15\text{ V}$ $I_{N(UH, VH, WH)} = 5\text{ V}$			130	μA
Quiescent V_{BS} Supply Current	I_{QBS}	$V_{BS} = 15\text{ V}$ $I_{N(UH, VH, WH)} = 5\text{ V}$			420	μA
Fault Output Voltage	V_{FOH}	$V_{SC} = 0\text{ V}$, V_{FO} Circuit: 4.7 kΩ to 5 V Pull-up	4.5	-	-	V
	V_{FOL}	$V_{SC} = 1\text{ V}$, V_{FO} Circuit: 4.7 kΩ to 5 V Pull-up	-	-	1.1	V
PWM Input Frequency	f_{PWM}	$T_C \leq 100^\circ\text{C}$, $T_J \leq 125^\circ\text{C}$	-	5	-	kHz
Allowable Input Signal Blanking Time considering Leg Arm-short	t_{dead}	$-20^\circ\text{C} \leq T_C \leq 100^\circ\text{C}$	3	-	-	us
Short-Circuit Trip Level	$V_{SC(ref)}$	$V_{CC} = 15\text{ V}$ (Note 5)	0.45	0.51	0.56	V
Sensing Voltage of IGBT Current	V_{SEN}	$T_C = 25^\circ\text{C}$, @ $R_{SC} = 56\ \Omega$, $R_{SU} = R_{SV} = R_{SW} = 0\ \Omega$ and $I_C = 30\text{ A}$ (Note Fig. 7)	0.45	0.51	0.56	V
Supply Circuit Under-Voltage Protection	UV_{CCD}	Detection Level	11.5	12	12.5	V
	UV_{CCR}	Reset Level	12	12.5	13	V
	UV_{BSD}	Detection Level	7.3	9.0	10.8	V
	UV_{BSR}	Reset Level	8.6	10.3	12	V
Fault Output Pulse Width	t_{FOD}	$C_{FOD} = 33\text{ nF}$ (Note 6)	1.4	1.8	2.0	ms
ON Threshold Voltage	$V_{IN(ON)}$	High-Side			0.8	V
OFF Threshold Voltage	$V_{IN(OFF)}$		3.0	-	-	V
ON Threshold Voltage	$V_{IN(ON)}$	Low-Side			0.8	V
OFF Threshold Voltage	$V_{IN(OFF)}$		3.0	-	-	V
Resistance of Thermistor	R_{TH}	@ $T_{TH} = 25^\circ\text{C}$ (Note Fig. 6)	-	50	-	kΩ
		@ $T_{TH} = 100^\circ\text{C}$ (Note Fig. 6)	-	3.4	-	kΩ

Note:

5. Short-circuit current protection is functioning only at the low-sides. It would be recommended that the value of the external sensing resistor (R_{SC}) should be selected around 56 Ω in order to make the SC trip-level of about 30 A at the shunt resistors (R_{SU}, R_{SV}, R_{SW}) of 0 Ω. For the detailed information about the relationship between the external sensing resistor (R_{SC}) and the shunt resistors (R_{SU}, R_{SV}, R_{SW}), please see Fig. 7.
6. The fault-out pulse width t_{FOD} depends on the capacitance value of C_{FOD} according to the following approximate equation: $C_{FOD} = 18.3 \times 10^{-6} \times t_{FOD}[F]$
7. T_{TH} is the temperature of thermistor

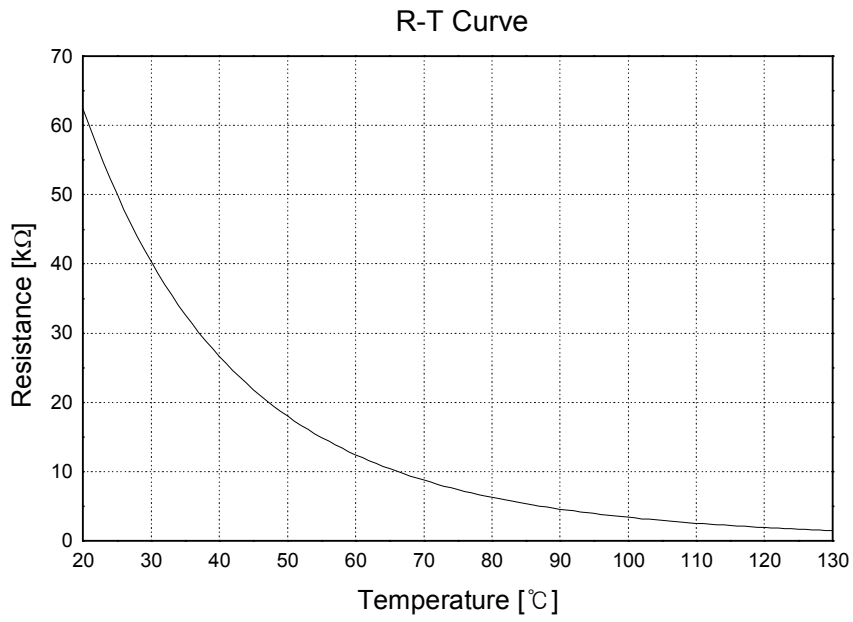

Fig. 6. R-T Curve of The Built-in Thermistor

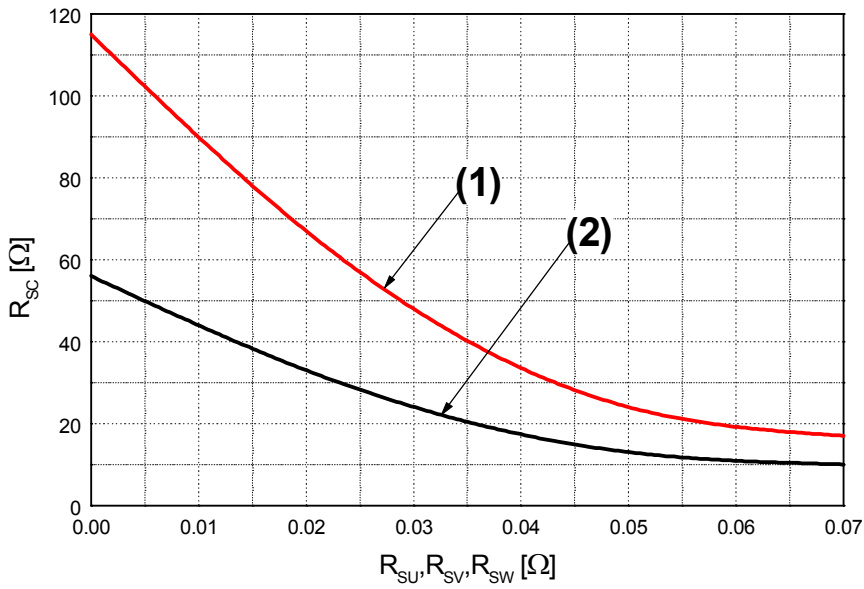

Fig. 7. R_{sc} Variation by change of Shunt Resistors (R_{SU}, R_{SV}, R_{SW}) for Short-Circuit Protection
 (1) @ around 100% Rated Current Trip (I_C = 20 A)
 (2) @ around 150% Rated Current Trip (I_C = 30 A)

Mechanical Characteristics and Ratings

Item	Condition		Limits			Unit
			Min.	Typ.	Max.	
Mounting Torque	Mounting Screw: M4 (Note 8 and 9)	Recommended 10 Kg•cm	8	10	12	Kg•cm
		Recommended 0.98 N•m	0.78	0.98	1.17	N•m
Ceramic Flatness		Note Fig.8	0	-	+120	um
Weight			-	35	-	g

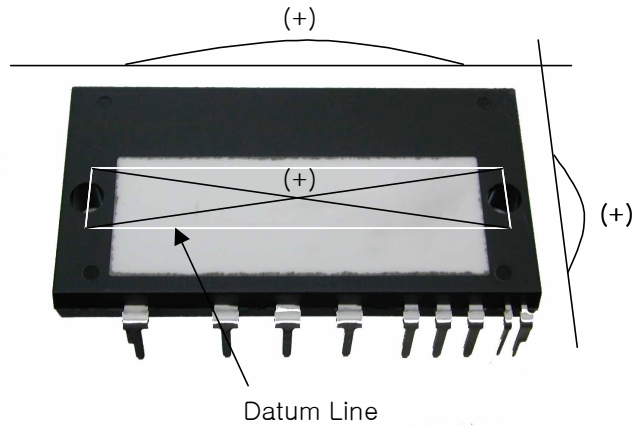

Fig. 8. Flatness Measurement Position of The Ceramic Substrate

Note:

- 8. Do not make over torque or mounting screws. Much mounting torque may cause ceramic cracks and bolts and Al heat-fin destruction.
- 9. Avoid one side tightening stress. Fig.9 shows the recommended torque order for mounting screws. Uneven mounting can cause the SPM® ceramic substrate to be damaged.

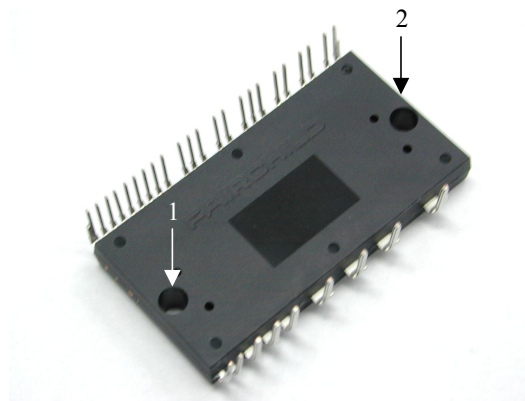
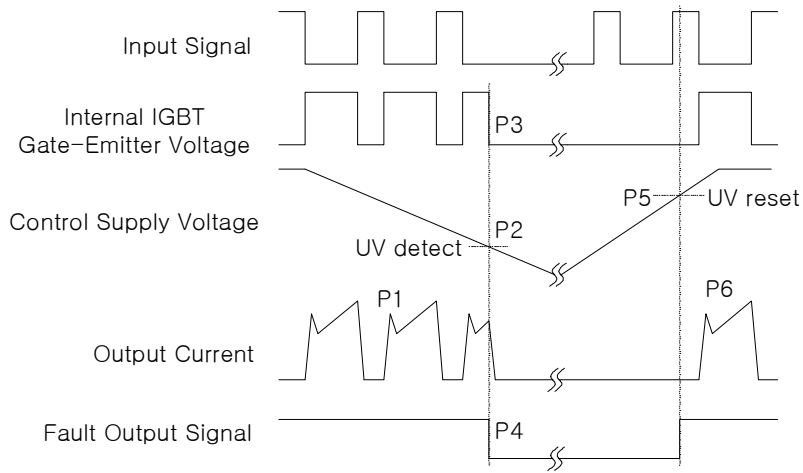

Fig. 9. Mounting Screws Torque Order

Recommended Operating Conditions

Item	Symbol	Condition	Values			Unit
			Min.	Typ.	Max.	
Supply Voltage	V_{PN}	Applied between P - N_U , N_V , N_W	-	300	400	V
Control Supply Voltage	V_{CC}	Applied between $V_{CC(UH)}$, $V_{CC(VH)}$, $V_{CC(WH)}$ - $COM_{(H)}$, $V_{CC(L)}$ - $COM_{(L)}$	13.5	15	16.5	V
High-side Bias Voltage	V_{BS}	Applied between $V_{B(U)}$ - $V_{S(U)}$, $V_{B(V)}$ - $V_{S(V)}$, $V_{B(W)}$ - $V_{S(W)}$	13.5	15	16.5	V
Blanking Time for Preventing Arm-short	t_{dead}	For Each Input Signal	3	-	-	us
PWM Input Signal	f_{PWM}	$T_C \leq 100^\circ C$, $T_J \leq 125^\circ C$	-	5	-	kHz
Input ON Threshold Voltage	$V_{IN(ON)}$	Applied between $IN_{(UH)}$, $IN_{(VH)}$, $IN_{(WH)}$ - $COM_{(H)}$	0 ~ 0.65			V
Input OFF Threshold Voltage	$V_{IN(OFF)}$	Applied between $IN_{(UL)}$, $IN_{(VL)}$, $IN_{(WL)}$ - $COM_{(L)}$	4 ~ 5.5			V

Time Charts of SPMs Protective Function



- P1 : Normal operation - IGBT ON and conducting current
- P2 : Under-Voltage detection
- P3 : IGBT gate interrupt
- P4 : Fault signal generation
- P5 : Under-Voltage reset
- P6 : Normal operation - IGBT ON and conducting current

Fig. 10. Under-Voltage Protection (Low-side)

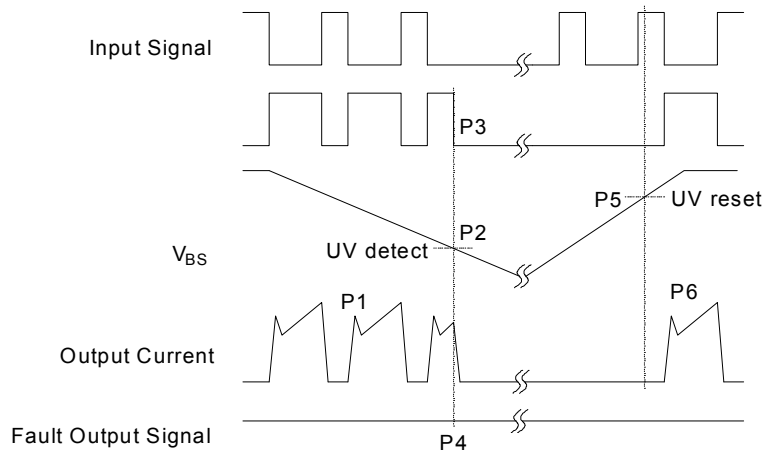

- P1 : Normal operation - IGBT ON and conducting current
- P2 : Under-Voltage detection
- P3 : IGBT gate interrupt
- P4 : No fault signal
- P5 : Under-Voltage reset
- P6 : Normal operation - IGBT ON and conducting current

Fig. 11. Under-Voltage Protection (High-side)

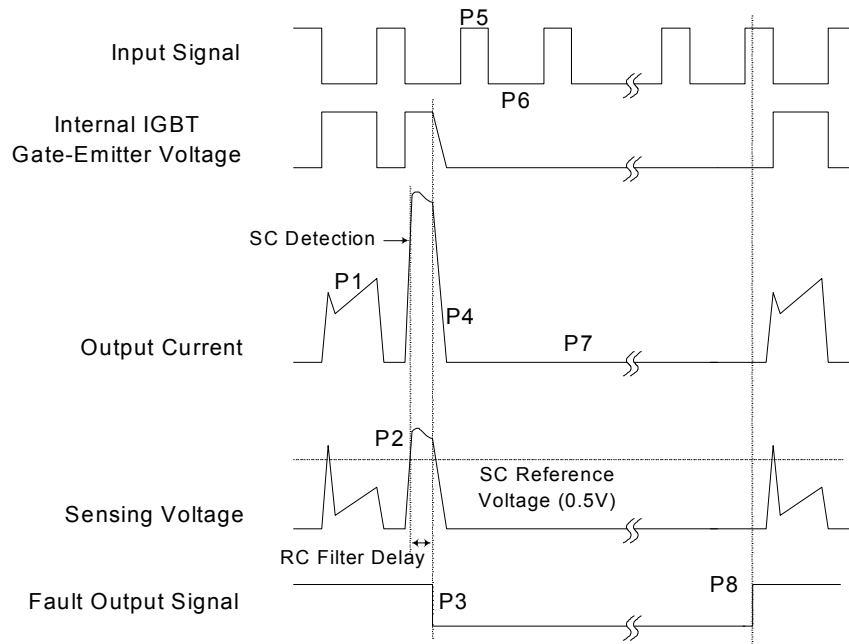

- P1 : Normal operation - IGBT ON and conducting current
- P2 : Short-Circuit current detection
- P3 : IGBT gate interrupt / Fault signal generation
- P4 : IGBT is slowly turned off
- P5 : IGBT OFF signal
- P6 : IGBT ON signal - but IGBT cannot be turned on during the fault Output activation
- P7 : IGBT OFF state
- P8 : Fault Output reset and normal operation start

Fig. 12. Short-Circuit Current Protection (Low-side Operation only)

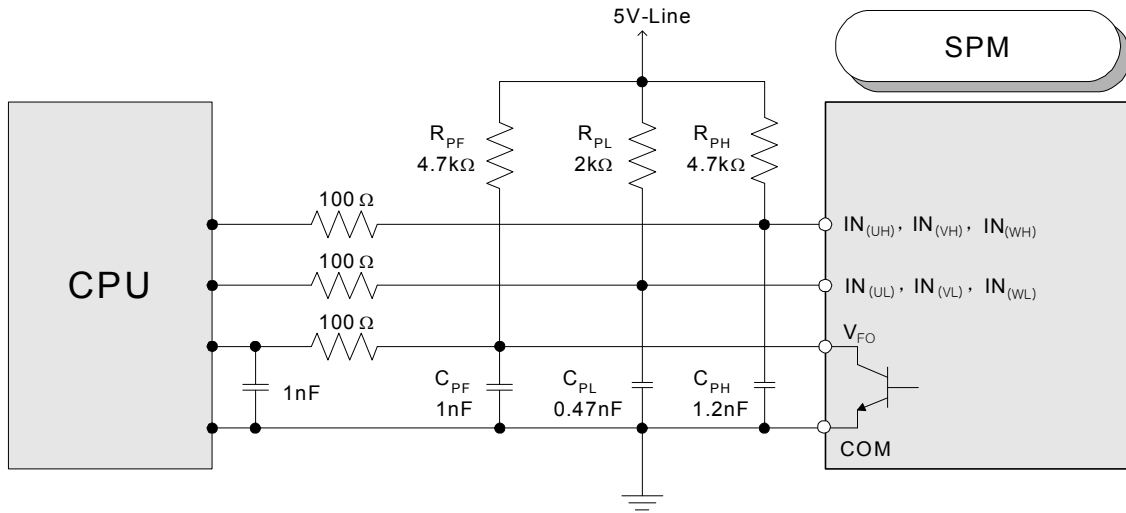

Note:

- 1) It would be recommended that by-pass capacitors for the gating input signals, IN_(UL), IN_(VL), IN_(WL), IN_(UH), IN_(VH) and IN_(WH) should be placed on the SPM® pins and on both sides of CPU and SPM for the fault output signal, V_{FO}, as close as possible.
- 2) The logic input is compatible with standard CMOS or LSTTL outputs.
- 3) R_{PL}C_{PL} / R_{PH}C_{PH} / R_{PF}C_{PF} coupling at each SPM input is recommended in order to prevent input/output signals' oscillation and it should be as close as possible to each of SPM pins.

Fig. 13. Recommended CPU I/O Interface Circuit

These Values depend on PWM Control Algorithm

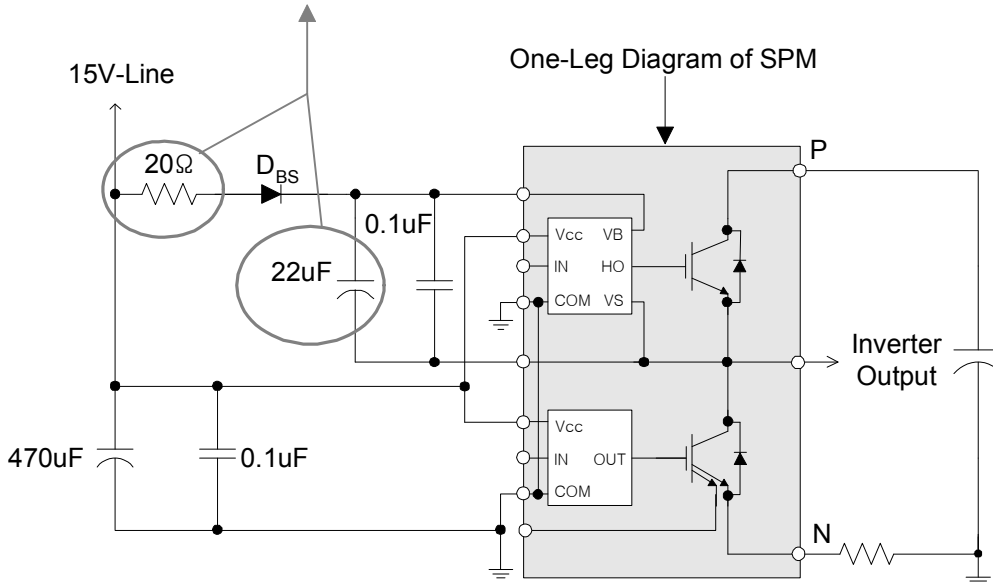

Note:

It would be recommended that the bootstrap diode, D_{BS}, has soft and fast recovery characteristics.

Fig. 14. Recommended Bootstrap Operation Circuit and Parameters

Detailed Package Outline Drawings

SPM32-AA

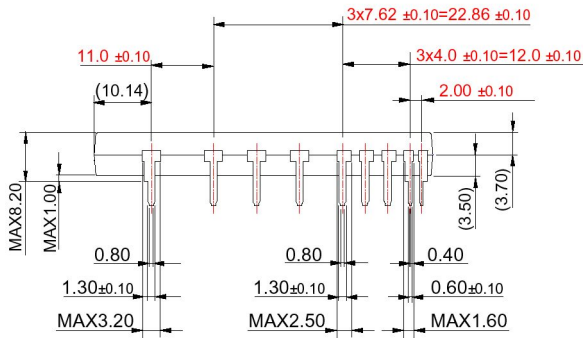
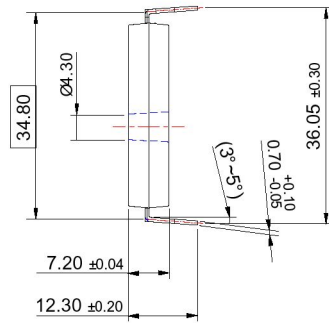
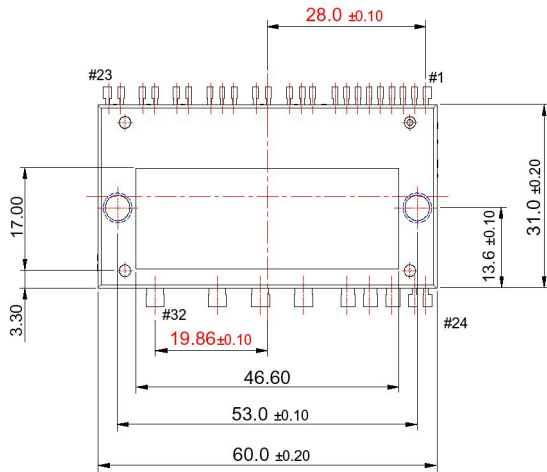
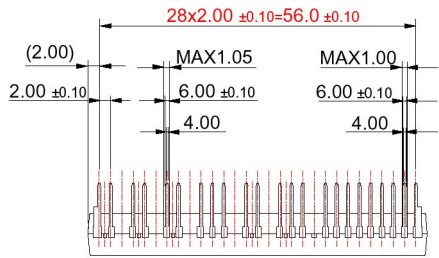





Dimensions in Millimeters



TRADEMARKS

The following includes registered and unregistered trademarks and service marks, owned by Fairchild Semiconductor and/or its global subsidiaries, and is not intended to be an exhaustive list of all such trademarks.

- | | | | |
|---|--|---|---|
| 2Cool™ | FPS™ |  | Sync-Lock™ |
| AccuPower™ | F-PFS™ | PowerTrench® |  |
| AX-CAP®* | FRFET® | PowerXS™ | TinyBoost™ |
| BitSiC™ | Global Power Resource™ | Programmable Active Droop™ | TinyBuck™ |
| Build it Now™ | GreenBridge™ | QFET® | TinyCalc™ |
| CorePLUS™ | Green FPS™ | QS™ | TinyLogic® |
| CorePOWER™ | Green FPS™ e-Series™ | Quiet Series™ | TINYOPTO™ |
| CROSSVOLT™ | Gmax™ | RapidConfigure™ | TinyPower™ |
| CTL™ | GTO™ |  | TinyPWM™ |
| Current Transfer Logic™ | IntelliMAX™ | Saving our world, 1mW/WkW at a time™ | TinyWire™ |
| DEUXPEED® | ISOPLANAR™ | SignalWise™ | TranSiC™ |
| Dual Cool™ | Making Small Speakers Sound Louder and Better™ | SmartMax™ | TriFault Detect™ |
| EcoSPARK® | MegaBuck™ | SMART START™ | TRUECURRENT®* |
| EfficientMax™ | MICROCOUPLER™ | Solutions for Your Success™ | μSerDes™ |
| ESBC™ | MicroFET™ | SPM® |  |
|  | MicroPak™ | STEALTH™ | UHC® |
| Fairchild® | MicroPak2™ | SuperFET® | Ultra FRFET™ |
| Fairchild Semiconductor® | MillerDrive™ | SuperSOT™-3 | UniFET™ |
| FACT Quiet Series™ | MotionMax™ | SuperSOT™-6 | VCX™ |
| FACT® | mWSaver™ | SuperSOT™-8 | VisualMax™ |
| FAST® | OptoHiT™ | SupreMOS® | VoltagePlus™ |
| FastvCore™ | OPTOLOGIC® | SyncFET™ | XS™ |
| FETBench™ | OPTOPLANAR® | | |

* Trademarks of System General Corporation, used under license by Fairchild Semiconductor.

DISCLAIMER

FAIRCHILD SEMICONDUCTOR RESERVES THE RIGHT TO MAKE CHANGES WITHOUT FURTHER NOTICE TO ANY PRODUCTS HEREIN TO IMPROVE RELIABILITY, FUNCTION, OR DESIGN. FAIRCHILD DOES NOT ASSUME ANY LIABILITY ARISING OUT OF THE APPLICATION OR USE OF ANY PRODUCT OR CIRCUIT DESCRIBED HEREIN; NEITHER DOES IT CONVEY ANY LICENSE UNDER ITS PATENT RIGHTS, NOR THE RIGHTS OF OTHERS. THESE SPECIFICATIONS DO NOT EXPAND THE TERMS OF FAIRCHILD'S WORLDWIDE TERMS AND CONDITIONS, SPECIFICALLY THE WARRANTY THEREIN, WHICH COVERS THESE PRODUCTS.

LIFE SUPPORT POLICY

FAIRCHILD'S PRODUCTS ARE NOT AUTHORIZED FOR USE AS CRITICAL COMPONENTS IN LIFE SUPPORT DEVICES OR SYSTEMS WITHOUT THE EXPRESS WRITTEN APPROVAL OF FAIRCHILD SEMICONDUCTOR CORPORATION.

As used herein:

1. Life support devices or systems are devices or systems which, (a) are intended for surgical implant into the body or (b) support or sustain life, and (c) whose failure to perform when properly used in accordance with instructions for use provided in the labeling, can be reasonably expected to result in a significant injury of the user.
2. A critical component in any component of a life support, device, or system whose failure to perform can be reasonably expected to cause the failure of the life support device or system, or to affect its safety or effectiveness.

ANTI-COUNTERFEITING POLICY

Fairchild Semiconductor Corporation's Anti-Counterfeiting Policy. Fairchild's Anti-Counterfeiting Policy is also stated on our external website, www.fairchildsemi.com, under Sales Support.

Counterfeiting of semiconductor parts is a growing problem in the industry. All manufacturers of semiconductor products are experiencing counterfeiting of their parts. Customers who inadvertently purchase counterfeit parts experience many problems such as loss of brand reputation, substandard performance, failed applications, and increased cost of production and manufacturing delays. Fairchild is taking strong measures to protect ourselves and our customers from the proliferation of counterfeit parts. Fairchild strongly encourages customers to purchase Fairchild parts either directly from Fairchild or from Authorized Fairchild Distributors who are listed by country on our web page cited above. Products customers buy either from Fairchild directly or from Authorized Fairchild Distributors are genuine parts, have full traceability, meet Fairchild's quality standards for handling and storage and provide access to Fairchild's full range of up-to-date technical and product information. Fairchild and our Authorized Distributors will stand behind all warranties and will appropriately address any warranty issues that may arise. Fairchild will not provide any warranty coverage or other assistance for parts bought from Unauthorized Sources. Fairchild is committed to combat this global problem and encourage our customers to do their part in stopping this practice by buying direct or from authorized distributors.

PRODUCT STATUS DEFINITIONS

Definition of Terms

Datasheet Identification	Product Status	Definition
Advance Information	Formative / In Design	Datasheet contains the design specifications for product development. Specifications may change in any manner without notice.
Preliminary	First Production	Datasheet contains preliminary data; supplementary data will be published at a later date. Fairchild Semiconductor reserves the right to make changes at any time without notice to improve design.
No Identification Needed	Full Production	Datasheet contains final specifications. Fairchild Semiconductor reserves the right to make changes at any time without notice to improve the design.
Obsolete	Not In Production	Datasheet contains specifications on a product that is discontinued by Fairchild Semiconductor. The datasheet is for reference information only.

Rev. I64