

DM74LS193 Synchronous 4-Bit Binary Counter with Dual Clock

General Description

The DM74LS193 circuit is a synchronous up/down 4-bit binary counter. Synchronous operation is provided by having all flip-flops clocked simultaneously, so that the outputs change together when so instructed by the steering logic. This mode of operation eliminates the output counting spikes normally associated with asynchronous (ripple-clock) counters.

The outputs of the four master-slave flip-flops are triggered by a LOW-to-HIGH level transition of either count (clock) input. The direction of counting is determined by which count input is pulsed while the other count input is held HIGH.

The counter is fully programmable; that is, each output may be preset to either level by entering the desired data at the inputs while the load input is LOW. The output will change independently of the count pulses. This feature allows the counters to be used as modulo-N dividers by simply modifying the count length with the preset inputs.

A clear input has been provided which, when taken to a high level, forces all outputs to the low level; independent

of the count and load inputs. The clear, count, and load inputs are buffered to lower the drive requirements of clock drivers, etc., required for long words.

These counters were designed to be cascaded without the need for external circuitry. Both borrow and carry outputs are available to cascade both the up and down counting functions. The borrow output produces a pulse equal in width to the count down input when the counter underflows.

Similarly, the carry output produces a pulse equal in width to the count down input when an overflow condition exists. The counters can then be easily cascaded by feeding the borrow and carry outputs to the count down and count up inputs respectively of the succeeding counter.

Features

- Fully independent clear input
- Synchronous operation
- Cascading circuitry provided internally
- Individual preset each flip-flop

Ordering Code:

Order Number	Package Number	Package Description
DM74LS193M	M16A	16-Lead Small Outline Integrated Circuit (SOIC), JEDEC MS-012, 0.150" Narrow Body
DM74LS193N	N16E	16-Lead Plastic Dual-In-Line Package (PDIP), JEDEC MS-001, 0.300" Wide

Connection Diagram

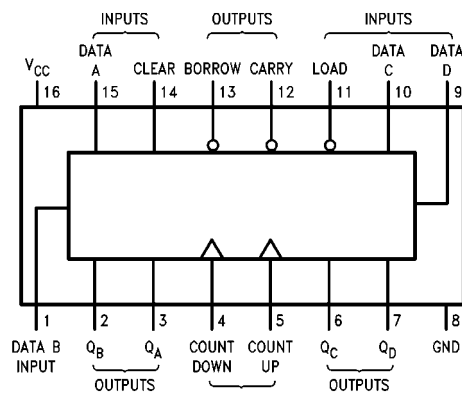

Logic Diagram

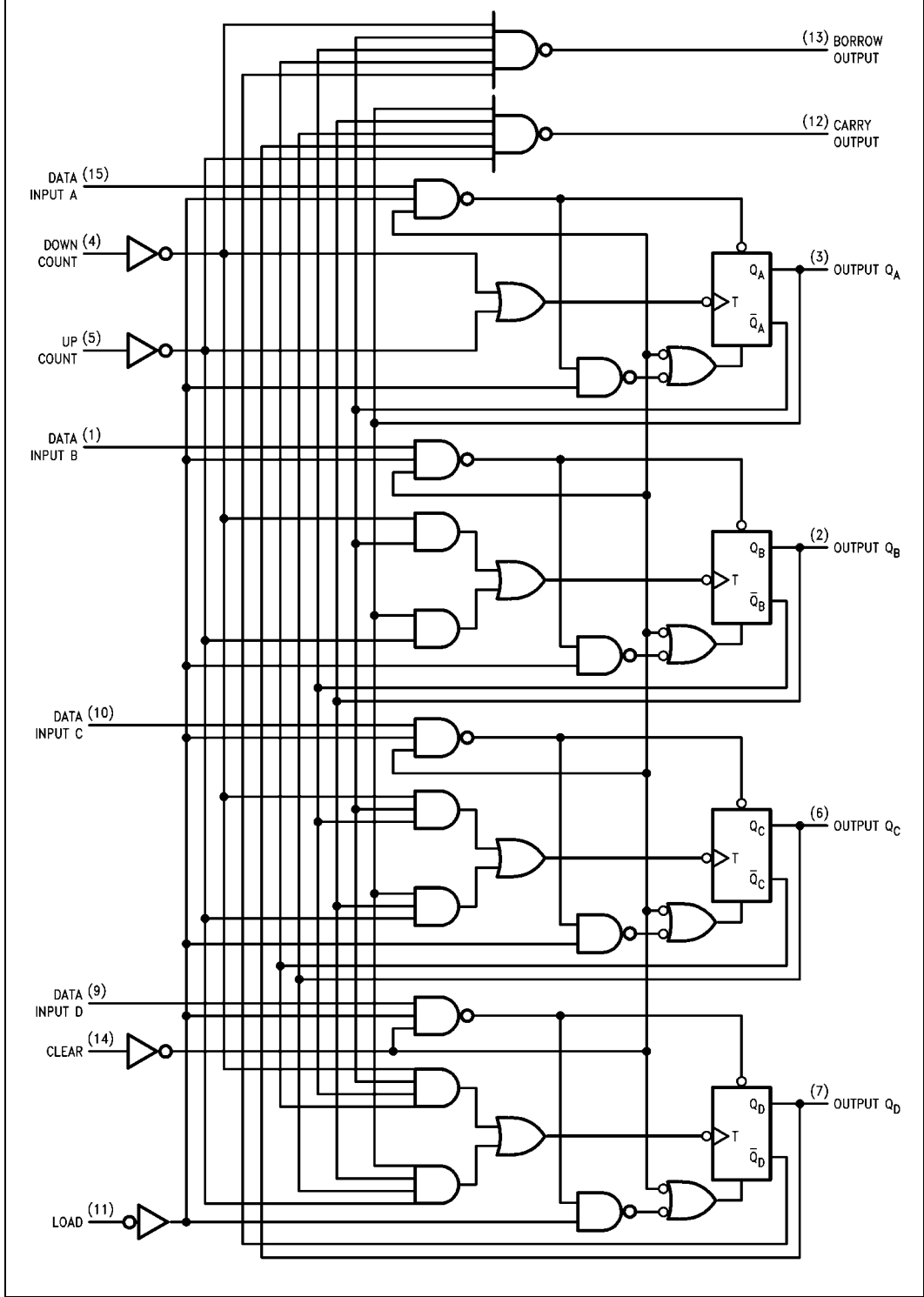

Timing Diagram

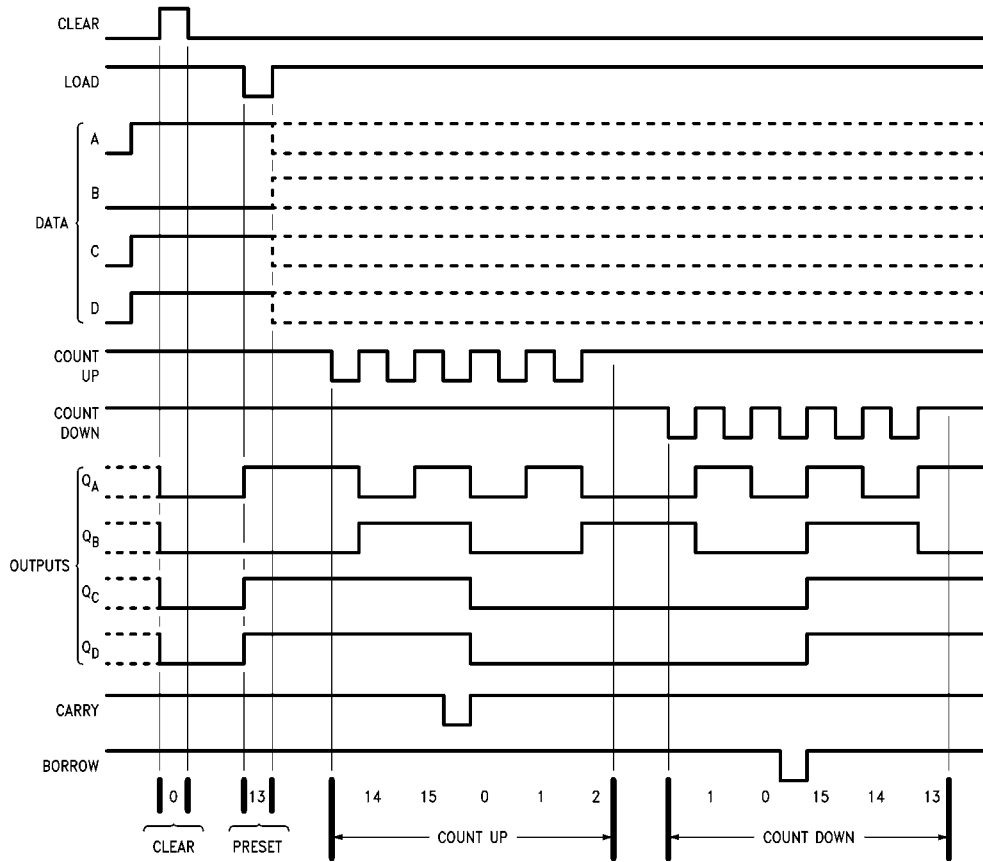

Note A: Clear overrides load, data, and count inputs

Note B: When counting up, count-down input must be HIGH; when counting down, count-up input must be HIGH.

Absolute Maximum Ratings(Note 1)

Operating Free Air Temperature Range	-0°C to +70°C
Supply Voltage	7V
Input Voltage	7V
Storage Temperature Range	-65°C to +125°C

Note 1: The "Absolute Maximum Ratings" are those values beyond which the safety of the device cannot be guaranteed. The device should not be operated at these limits. The parametric values defined in the Electrical Characteristics tables are not guaranteed at the absolute maximum ratings. The "Recommended Operating Conditions" table will define the conditions for actual device operation.

Recommended Operating Conditions

Symbol	Parameter	Min	Nom	Max	Units
V _{CC}	Supply Voltage	4.75	5	5.25	V
V _{IH}	HIGH Level Input Voltage	2			V
V _{IL}	LOW Level Input Voltage			0.8	V
I _{OH}	HIGH Level Output Current			-0.4	mA
I _{OL}	LOW Level Output Current			8	mA
f _{CLK}	Clock Frequency (Note 2)	0		25	MHz
	Clock Frequency (Note 3)				
t _W	Pulse Width of any Input (Note 4)	20			ns
t _{SU}	Data Setup Time (Note 4)	20			ns
t _H	Data Hold Time (Note 4)	0			ns
t _{EN}	Enable Time to Clock (Note 4)	40			ns
T _A	Free Air Operating Temperature	0		70	°C

Note 2: C_L = 15 pF, R_L = 2 kΩ, I_A = 25°C and V_{CC} = 5V.

Note 3: C_L = 50 pF, R_L = 2 kΩ, I_A = 25°C and V_{CC} = 5V.

Note 4: T_A = 25°C and V_{CC} = 5V.

DC Electrical Characteristics

Symbol	Parameter	Conditions	Min	Typ	Max	Units
				(Note 5)		
V _I	Input Clamp Voltage	V _{CC} = Min, I _I = -18 mA			-1.5	V
V _{OH}	HIGH Level Output Voltage	V _{CC} = Min, I _{OH} = Max	2.5	3.4		V
		V _{IL} = Max, V _{IH} = Min	2.7	3.4		
V _{OL}	LOW Level Output Voltage	V _{CC} = Min, I _{OL} = Max		0.25	0.4	V
		V _{IL} = Max, V _{IH} = Min		0.35	0.5	
		I _{OL} = 4 mA, V _{CC} = Min		0.25	0.4	
I _I	Input Current @ Max Input Voltage	V _{CC} = Max, V _I = 7V			0.1	mA
I _{IH}	HIGH Level Input Current	V _{CC} = Max, V _I = 2.7V			20	μA
I _{IL}	LOW Level Input Current	V _{CC} = Max, V _I = 0.4V			-0.4	mA
I _{OS}	Short Circuit Output Current	V _{CC} = Max	-20		-100	mA
		(Note 6)	-20		-100	
I _{CC}	Supply Current	V _{CC} = Max (Note 7)		19	34	mA

Note 5: All typicals are at V_{CC} = 5V, T_A = 25°C.

Note 6: Not more than one output should be shorted at a time, and the duration should not exceed one second.

Note 7: I_{CC} is measured with all outputs open, CLEAR and LOAD inputs grounded, and all other inputs at 4.5V.

AC Electrical Characteristics

Symbol	Parameter	From (Input) To (Output)	$R_L = 2\text{ k}\Omega$				Units
			$C_L = 15\text{ pF}$		$C_L = 50\text{ pF}$		
			Min	Max	Min	Max	
f_{MAX}	Maximum Clock Frequency		25		20		MHz
t_{PLH}	Propagation Delay Time LOW-to-HIGH Level Output	Count Up to Carry		26		30	ns
t_{PHL}	Propagation Delay Time HIGH-to-LOW Level Output	Count Up to Carry		24		36	ns
t_{PLH}	Propagation Delay Time LOW-to-HIGH Level Output	Count Down to Borrow		24		29	ns
t_{PHL}	Propagation Delay Time HIGH-to-LOW Level Output	Count Down to Borrow		24		32	ns
t_{PLH}	Propagation Delay Time LOW-to-HIGH Level Output	Either Count to Any Q		38		45	ns
t_{PHL}	Propagation Delay Time HIGH-to-LOW Level Output	Either Count to Any Q		47		54	ns
t_{PLH}	Propagation Delay Time LOW-to-HIGH Level Output	Load to Any Q		40		41	ns
t_{PHL}	Propagation Delay Time HIGH-to-LOW Level Output	Load to Any Q		40		47	ns
t_{PHL}	Propagation Delay Time HIGH-to-LOW Level Output	Clear to Any Q		35		44	ns

Physical Dimensions inches (millimeters) unless otherwise noted

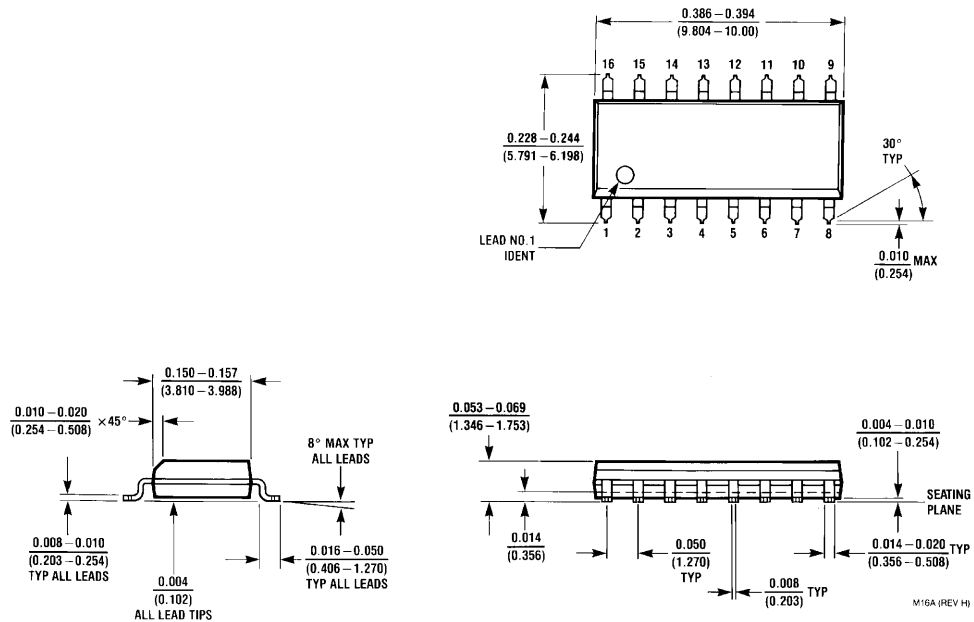

**16-Lead Small Outline Integrated Circuit (SOIC), JEDEC MS-012, 0150" Narrow Body
Package Number M16A**

Physical Dimensions inches (millimeters) unless otherwise noted (Continued)

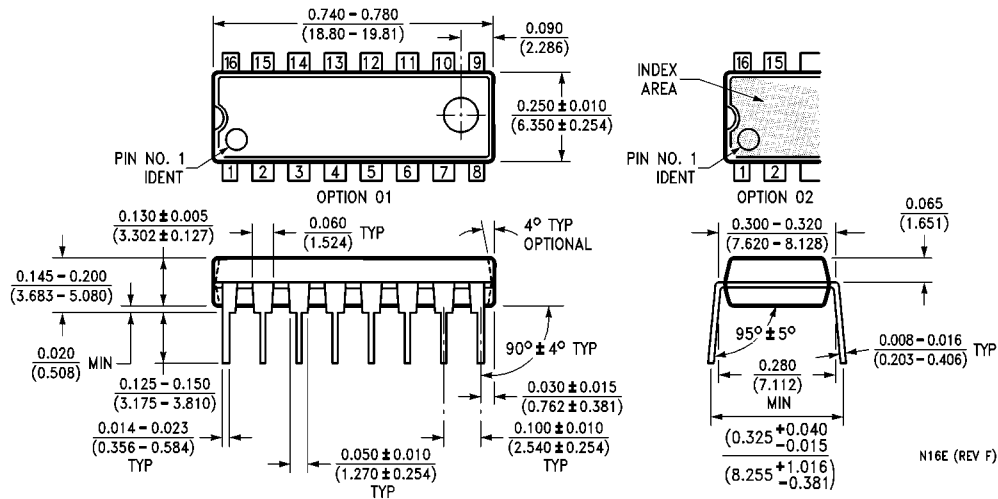

16-Lead Plastic Dual-In-Line Package (PDIP), JEDEC MS-001, 0.300" Wide Package Number N16E

Fairchild does not assume any responsibility for use of any circuitry described, no circuit patent licenses are implied and Fairchild reserves the right at any time without notice to change said circuitry and specifications.

LIFE SUPPORT POLICY

FAIRCHILD'S PRODUCTS ARE NOT AUTHORIZED FOR USE AS CRITICAL COMPONENTS IN LIFE SUPPORT DEVICES OR SYSTEMS WITHOUT THE EXPRESS WRITTEN APPROVAL OF THE PRESIDENT OF FAIRCHILD SEMICONDUCTOR CORPORATION. As used herein:

1. Life support devices or systems are devices or systems which, (a) are intended for surgical implant into the body, or (b) support or sustain life, and (c) whose failure to perform when properly used in accordance with instructions for use provided in the labeling, can be reasonably expected to result in a significant injury to the user.
2. A critical component in any component of a life support device or system whose failure to perform can be reasonably expected to cause the failure of the life support device or system, or to affect its safety or effectiveness.

www.fairchildsemi.com

This datasheet has been download from:

www.datasheetcatalog.com

Datasheets for electronics components.