

KBU8A ... KBU8M

Silicon-Bridge-Rectifiers Silizium-Brückengleichrichter

Version 2008-01-31

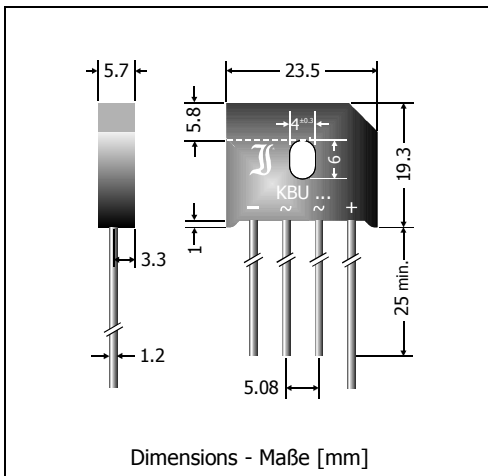

Nominal current Nennstrom	8 A
Alternating input voltage Eingangswchelsspannung	35...700 V
Plastic case Kunststoffgehäuse	23.5 x 5.7 x 19.3 [mm]
Weight approx. Gewicht ca.	7 g
Plastic material has UL classification 94V-0 Gehäusematerial UL94V-0 klassifiziert	
Standard packaging bulk Standard Lieferform lose im Karton	



Recognized Product – Underwriters Laboratories Inc.® File E175067
Anerkanntes Produkt – Underwriters Laboratories Inc.® Nr. E175067

Maximum ratings**Grenzwerte**

Type Typ	Max. alternating input voltage Max. Eingangswchelsspannung V_{VRMS} [V]	Repetitive peak reverse voltage Periodische Spitzensperspannung V_{RRM} [V] ¹⁾
KBU8A	35	50
KBU8B	70	100
KBU8D	140	200
KBU8G	280	400
KBU8J	420	600
KBU8K	560	800
KBU8M	700	1000

Repetitive peak forward current Periodischer Spitzenstrom	$f > 15$ Hz	I_{FRM}	50 A ²⁾
Peak forward surge current, 50/60 Hz half sine-wave Stoßstrom für eine 50/60 Hz Sinus-Halbwelle	$T_A = 25^\circ\text{C}$	I_{FSM}	270/300 A
Rating for fusing, $t < 10$ ms Grenzlastintegral, $t < 10$ ms	$T_A = 25^\circ\text{C}$	i^2t	375 A ² s
Operating junction temperature – Sperrschichttemperatur Storage temperature – Lagerungstemperatur		T_j T_s	-50...+150°C -50...+150°C
Admissible torque for mounting Zulässiges Anzugsdrehmoment		M3.5	9 ± 10% lb.in. 1 ± 10% Nm

1 Valid per diode – Gültig pro Diode

2 Valid, if leads are kept at ambient temperature $T_A = 50^\circ\text{C}$ at a distance of 5 mm from case
Gültig, wenn die Anschlussdrähte in 5 mm vom Gehäuse auf Umgebungstemperatur $T_A = 50^\circ\text{C}$ gehalten werden

Characteristics

Kennwerte

Max. rectified current without cooling fin Dauergrenzstrom ohne Kühlblech	$T_A = 50^\circ\text{C}$	R-load C-load	I_{FAV} I_{FAV}	$5.6\text{ A}^1)$ $4.5\text{ A}^1)$
Max. rectified current with cooling fin 300 cm ² Dauergrenzstrom mit Kühlblech 300 cm ²	$T_A = 50^\circ\text{C}$	R-load C-load	I_{FAV} I_{FAV}	8.0 A 6.4 A
Forward voltage – Durchlass-Spannung	$T_j = 25^\circ\text{C}$	$I_F = 8\text{ A}$	V_F	$< 1.0\text{ V}^2)$
Leakage current – Sperrstrom	$T_j = 25^\circ\text{C}$	$V_R = V_{RRM}$	I_R	$< 10\ \mu\text{A}$
Thermal resistance junction to case Wärmewiderstand Sperrschicht – Gehäuse			R_{thc}	$< 3.0\text{ K/W}$

Type Typ	Max. admissible load capacitor Max. zulässiger Ladekondensator C_L [μF]	Min. required protective resistor Min. erforderl. Schutzwiderstand R_t [Ω]
KBU8A	20000	0.2
KBU8B	10000	0.4
KBU8D	5000	0.8
KBU8G	2500	1.6
KBU8J	1500	2.4
KBU8K	1000	3.2
KBU8M	800	4.0

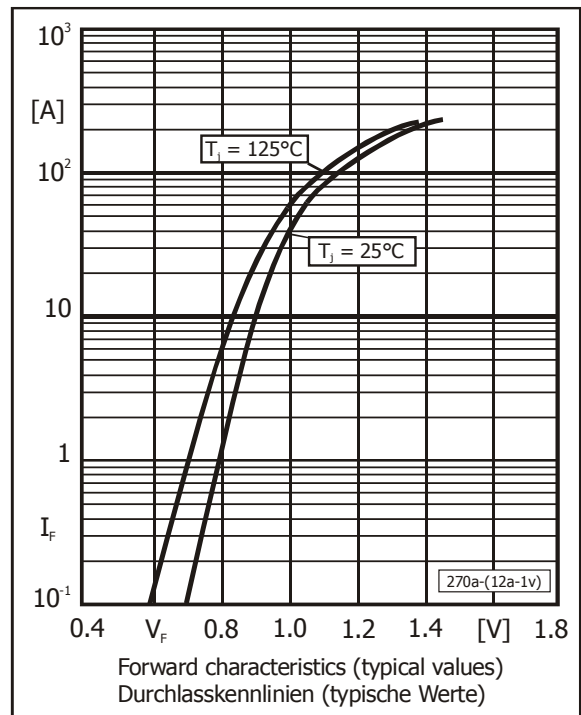
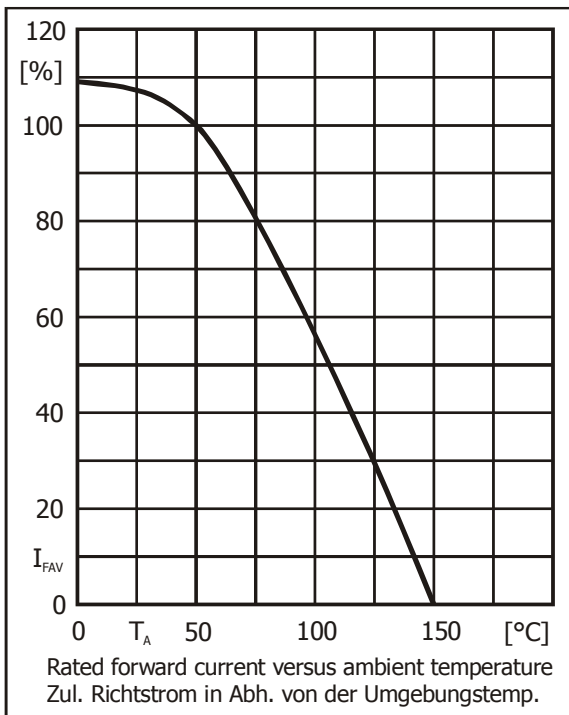

1 Valid, if leads are kept at ambient temperature $T_A = 50^\circ\text{C}$ at a distance of 5 mm from case
Gültig, wenn die Anschlussdrähte in 5 mm vom Gehäuse auf Umgebungstemperatur $T_A = 50^\circ\text{C}$ gehalten werden
2 Valid per diode – Gültig pro Diode