

CI51 Series 3.96mm(.156") Wire to Board Connector

CI

- With locking tab
- Mate with CI51, CI77 header
- Can be used CI51 crimp clip terminal
- Terminal accommodated AWG #18 ~ #24

Construction

- Insulator: Nylon 66 UL 94V-2 , Color Nature
- Terminal: Tin plated Brass or Phosphor Bronze

RoHS Compliant

RU :E159616

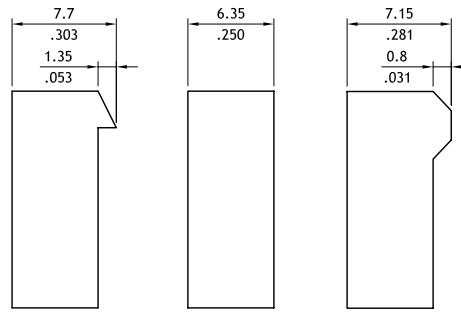
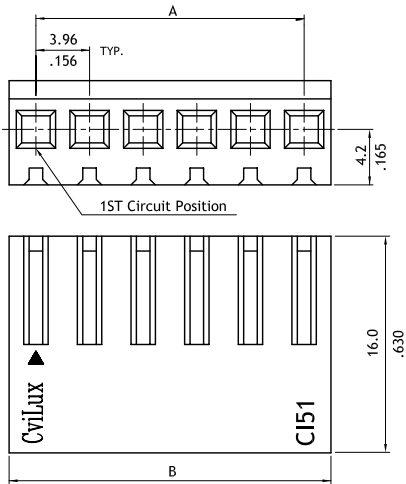
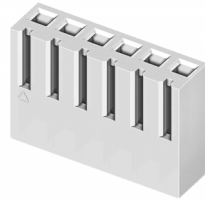

Circuits	Dimension	
	A	B
2	3.96(.156)	8.0(.315)
3	7.92(.312)	12.0(.472)
4	11.88(.468)	15.9(.626)
5	15.84(.624)	19.9(.783)
6	19.80(.780)	23.9(.941)
7	23.76(.935)	28.0(1.102)
8	27.72(1.091)	32.0(1.260)
9	31.68(1.247)	35.9(1.413)
10	35.64(1.403)	39.9(1.571)
11	39.60(1.559)	43.9(1.728)
12	43.56(1.715)	47.8(1.882)
13	47.52(1.871)	51.8(2.039)
14	51.48(2.027)	55.7(2.193)
15	55.44(2.183)	59.7(2.350)
16	59.40(2.339)	63.7(2.508)
17	63.36(2.494)	67.6(2.661)
18	67.32(2.650)	71.6(2.819)
19	71.28(2.806)	75.5(2.972)
20	75.24(2.962)	79.5(3.130)

P/N:CI51**S0000 P/N:CI51**S000R P/N:CI51**S00DR

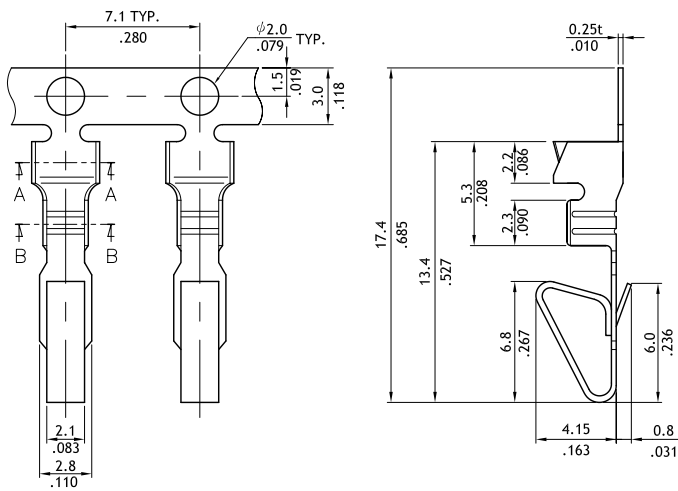

Part No.	Wire Range	Insulation	Thickness	Reel Q'ty
CI51T031*E0	AWG #18-#24	2.48 (.098) MAX.	0.25mm	5,000 PCS

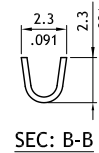
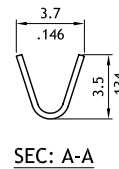

Ordering Code

1 CI51 **2** 20 **3** S **4** 0000

1 CI51 **2** T03 **3** 1 **4** B **5** E **6** 0

- 1** Series No.
- 2** No. of Circuits: 02 to 20
- 3** S= Connector housing
- 4** Other options:
0000= With locking Ramp(Standard)
000R= Without locking Ramp
00DR= Low force locking Ramp
*Special options Consult manufacturer

- 1** Series No.
- 2** Type: T03= AWG #18~#24
- 3** Plating : 1= Tin over Nickel plated
- 4** Material: B= Brass ; P=Phosphor Bronze
- 5** Plating method: E= Pre-tinned
- 6** Other options:
0= Standard

WIRE TO BOARD

