

THE GLOBAL EXPERT  
IN **SOLID STATE RELAY**  
TECHNOLOGY



■ Food Preparation Equipment



■ Plastic Molding



■ Lighting Control



**CST**  
CUSTOM SENSORS & TECHNOLOGIES

**crydom**<sup>®</sup>  
Dual Solid State Relays

# crydom®

**C**rydom has a distinguished record of providing advanced, high quality products with timely delivery and competitive pricing. Your success in today's fastpaced global markets hinges on working with suppliers who respond quickly and appropriately to your every need.

In addition to an extensive selection of catalog off-the-shelf items, Crydom offers custom-designed solid state relays. Fact is we specialize in satisfying the most demanding environmental and performance requirements our customers can devise. Give us your specs, and watch us exceed your expectations!

At Crydom's custom-built **100,000 square foot manufacturing facility**, virtually everything is accomplished in-house to assure complete control over delivery, production, and above all quality. With design, development, manufacturing and management personnel

under one roof, we're geared for fast response to your requirements.

In **Design Engineering**, we focus on pushing performance, reliability and quality standards ever higher. Working under a conservative design and rating philosophy, Crydom's seasoned engineering team makes extensive use of CAD to optimize design of mechanical parts.

As a result of these efforts, Crydom has acquired an impressive list of patents in solid state relay technology, while continuing to create new circuit and technology-related inventions as part of our ongoing R & D programs.

Once the design is solidified, **Production Engineering** is responsible for the engineering

control of the techniques used throughout manufacturing. This department works closely with our design engineering group, establishes assembly processes, and oversees a comprehensive on-premises machine shop which fabricates our assembly fixtures.

As the work progresses, **Material and Production Control** employ our advanced computer system, upgraded with our customized software to keep manufacturing operations humming. The computer system employs integral MRP and MSP capabilities to generate detailed scheduling and planning information.

**Ceramic Hybrid Manufacturing** also is performed in-house. Crydom manufactures all metallized ceramic substrates used in our relays — a major factor in product performance and reliability, including direct bond copper substrates.



[www.crydom.com](http://www.crydom.com)

**Quality Assurance** conducts ongoing product reliability verification tests, gathering precise data on the quality of our power semiconductor vendors and the silicon chips they provide. Additional tests are performed to meet specific customer burn-in requirements.

Crydom tests are exhaustive, including **100% verification** at final test. After units are completely assembled, they must pass a complete set of electrical tests, which are performed twice, once prior to encapsulation and then again afterward.

Because of our dedication to quality, Crydom was one of the first American companies to achieve full certification to the demanding standards of ISO 9001. In addition, most Crydom products are approved by UL, CSA, VDE, TUV and carry the CE Mark signifying conformance with the latest European directives. Certain panel mount and din rail mount relays carry UL 508A SCCR ratings.

Learn how an alliance with the world leader in solid state relays can pay off for you. For details, call your authorized Crydom distributor today.



## **DUAL SOLID STATE RELAYS**

### **Dual Output SSRs**

For decades Crydom has manufactured top quality Dual Solid State Relays in addition to its standard single and three phase SSR lines. All Crydom “D” and “H12” series Dual SSRs have two totally independent AC output relays in a single standard panel mount package making them ideal for a wide variety of applications including Heating, Lighting and Motion Control.

Each Dual SSR has two outputs controlled by two independent inputs. This allows engineers using multiple Solid State Relays in a panel to save space in many applications. Fast-on termination suitable for rated load currents to 40 amps/ 530 VAC per channel are standard. Terminations for the input controls are either square pins or fast-on connectors. Utilizing dual SCR’s for the AC switch output with internal snubber. Crydom Dual SSRs provide greater protection against false triggering. Model choices include zero voltage or random turn-on switching.

### **Evolution Dual SSRs**

Crydom has used innovation and technology to expand its line of Dual SSRs creating the **Evolution Dual** series. Evolving from Crydom’s successful “D” and “H12” series of Dual SSRs, the **Evolution Duals** offer an improved mechanical and thermal design providing higher capacity outputs and significantly increased power density. Screw termination suitable for rated load currents to 50 amps/ 600 VAC per channel is standard in either “SSR” or “Contactor” output termination configurations. Each AC output channel features high power SCRs with high surge ratings and is available with either zero voltage or random turn on.

The new generation of Dual SSRs with four different input termination options (pin, locking connector, detachable barriers w/screws, and direct wire) are available with three different input voltage ratings including a wide range (4 to 32 VDC) current regulated version.

The new two channel relays are available with an innovative optional clear IP20 touch safe cover allowing a clear view of the power lead terminations while providing touch safe operation. Crydom’s AC output **Evolution Dual Solid State Relays** also feature LED input status indicators for each channel.

Crydom Dual SSRs are UL and cUL recognized, TUV approved, RoHS compliant and CE certified.



## Evolution Dual Relays AC Output



25-50 Amp  
280/600 VAC

- 25A & 50A Output rating per channel @ 40°C
- 120/240 & 480VAC Operating voltage rating
- 4-15, 15-32 & 4-32VDC Control input options
- Four input termination options available
- Top-bottom or left-right output screw connections available
- Zero voltage or random turn-on available
- SCR output for heavy industrial loads
- Industry standard panel mount package
- IP20 Protective cover available
- Input status LED indicators for each channel
- CE & RoHS compliant, UL & cUL recognized

### OUTPUT SPECIFICATIONS ①

	CX2425XXXX	CX2450XXXX	CX4825XXXX	CX4850XXXX
Operating Voltage (47-63 Hz) [Vrms]	24-280	24-280	48-600	48-600
Load Current Range [Arms] ②	0.15-25	0.15-50	0.15-25	0.15-50
Maximum Surge Current (1 cycle) [Apk] @ 60 Hz	300	750	300	750
Maximum Surge Current (1 cycle) [Apk] @ 50 Hz	275	710	275	710
Transient Overvoltage [Vpk]	600	600	1200	1200
Maximum On-State Voltage Drop @ Rated Current [Vpk]	1.3	1.3	1.3	1.3
Thermal Resistance Junction to Case (RqJC) [°C/W]	0.65	0.33	0.65	0.33
Maximum I <sup>2</sup> t for Fusing (8.3 msec.) [A <sup>2</sup> sec]	370	2320	370	2320
Maximum I <sup>2</sup> t for Fusing (10 msec.) [A <sup>2</sup> sec]	380	2520	380	2520
Minimum Off-State dv/dt @ Max. Rated Voltage [V/μsec] ③	500	500	500	500
Off-state leakage [mA] (at max. line voltage & Ta = 25°C)	0.1	0.1	0.25	0.25
Maximum Turn-On Time ④	1/2 cycle	1/2 cycle	1/2 cycle	1/2 cycle
Maximum Turn-Off Time	1/2 cycle	1/2 cycle	1/2 cycle	1/2 cycle
Power Factor (Minimum) with Maximum Load	0.5	0.5	0.5	0.5

### INPUT SPECIFICATIONS ①

	CXXXDXXX	CXXXEXXX	CXXXWXXX
Control Voltage Range [VDC]	4-15	15-32	4-32
Minimum Turn-On Voltage [VDC]	4	15	4
Minimum Turn-Off Voltage [VDC]	1	1	1
Nominal Input Impedance [Ohms]	300	1500	See note 5
Typical Input Current [mA]	16 @ 5 VDC	18 @ 24 VDC	10 @ 12 VDC

### GENERAL SPECIFICATIONS

Dielectric Strength 50/60Hz Input/Output [Vrms]	4000
Dielectric Strength 50/60Hz Input/Output/Baseplate [Vrms]	2500
Insulation Resistance (Min.) @ 500 VDC [Ohms]	10 <sup>9</sup>
Maximum Capacitance Input/Output [pF]	10
Ambient Operating Temperature Range [°C]	-40 to 80
Ambient Storage Temperature Range [°C]	-40 to 125

### MECHANICAL SPECIFICATIONS

Weight (Typical)	0.25 lb (100 grs)
Encapsulation	Thermally Conductive Epoxy
Terminals	Screw Type Output: 8-32
Maximum Torque (Output Terminals)	20 in lbs (2.2 Nm)
Maximum Wire Size (Output Terminals)	AWG #8 with terminals. AWG #10 Stranded

- ① All parameters at 25°C and per channel unless otherwise specified.  
 ② Off-State dv/dt test method per EIA/NARM standard RS-443, paragraph 13.11.1  
 ③ Heat sinking required, see derating curves.  
 ④ Turn-On time for random turn-on (R) versions is 0.1 msec.  
 ⑤ Input circuit incorporates active current limitation.

### Wiring Diagrams

#### SSR Output Configuration "U" Option Top-Bottom Line/Load Connections

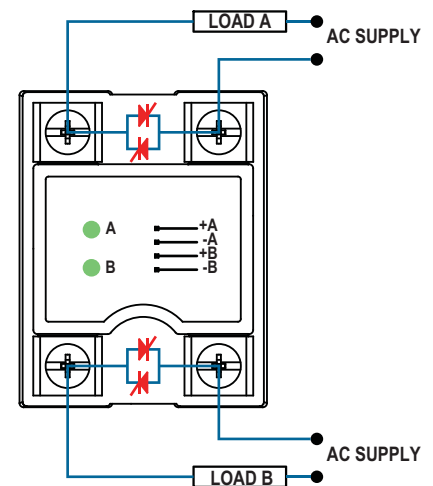

#### Contactor Output Configuration "V" Option Left-Right Line/Load Connections

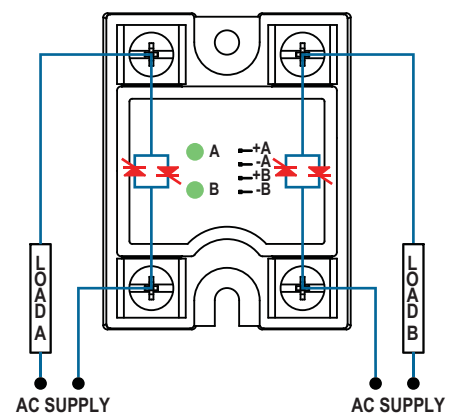

## Part Number Nomenclature

<p><b>Cover Option</b>  <b>C:</b> IP20  <b>D:</b> IP00 (No cover)</p>	<p><b>Output Current Rating per Channel</b>  <b>25:</b> 25 Amps rms  <b>50:</b> 50 Amps rms                  @ Ta= 40°C</p>	<p><b>Input Connector Options</b>                  1, 2, 3, or 4</p>	<p><b>Options</b>  <b>Blank:</b> Zero Turn On  <b>R:</b> Random Turn On  <b>H:</b> TP- 01 thermal pad installed on relay</p>
<p><b>C</b> <b>D</b> <b>24</b> <b>25</b> <b>D</b> <b>1</b> <b>V</b> <b>R</b></p>			
<p><b>Evolution Dual Series</b></p>	<p><b>Output Voltage @ 50/60 Hz</b>  <b>24:</b> 24-280 VAC  <b>48:</b> 48-600 VAC</p>	<p><b>Input Control</b>  <b>D:</b> 4-15 VDC  <b>E:</b> 15-32 VDC  <b>W:</b> 4-32 VDC</p>	<p><b>Output Terminal Orientation</b>  <b>U:</b> A channel on top/ B on bottom (SSR output configurations)  <b>V:</b> A channel on left/ B on right (Contactor output configurations)                  (See wiring diagrams)</p>

● Required for valid part number  
● For options only and not required for valid part number

## Derating Curves

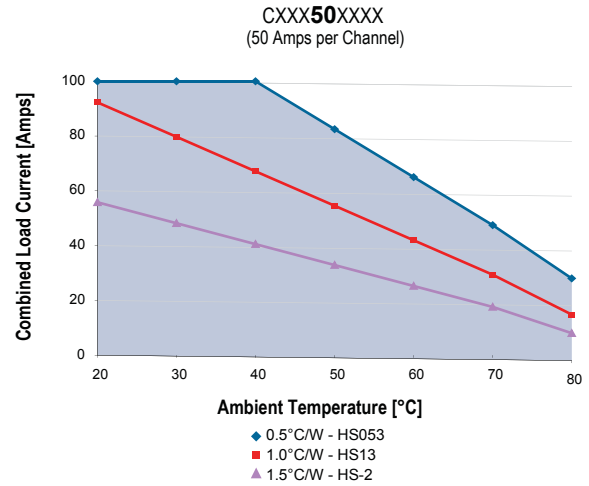
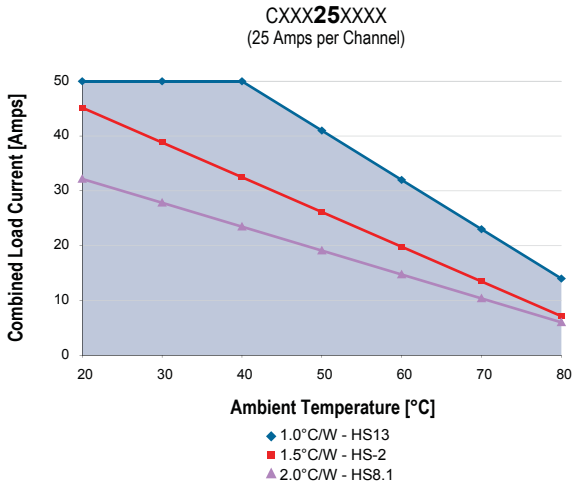





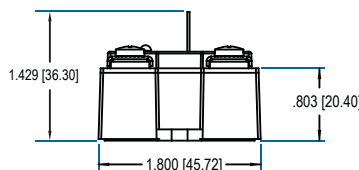
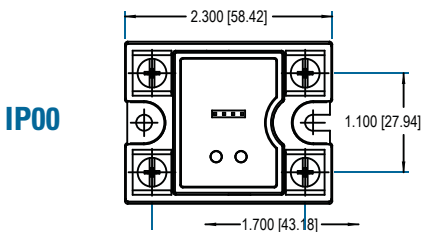
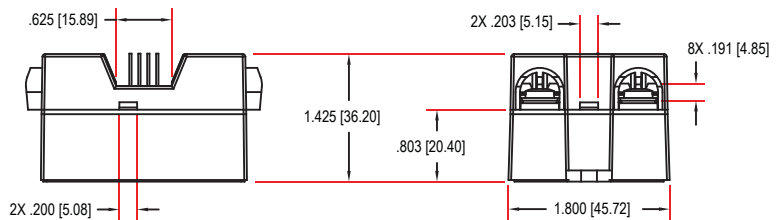
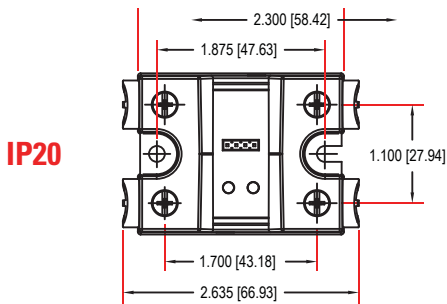

## Mechanical Dimensions

Tolerances: ± 0.02 in / 0.5 mm  
 All dimensions are in: inches [millimeters]

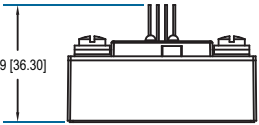
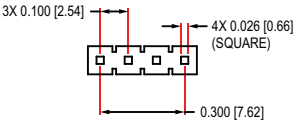

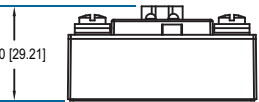
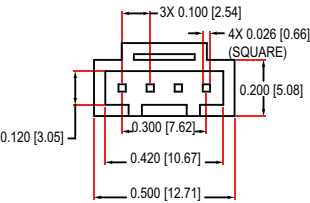
To view available Installation Sheet scan the QR code with your smartphone or visit [www.crydom.com](http://www.crydom.com)

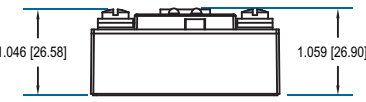
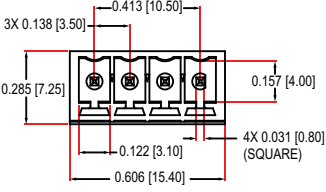
## Available Input Connector Options

	MECHANICAL DIMENSIONS (shown without IP20 cover)	INPUT CONNECTOR DIMENSIONS	SUGGESTED MATING CONNECTORS/PLUGS
 <p><b>Four Pin Standard</b></p>	 <p>1.429 [36.30]</p> <p>INPUT CONNECTOR OPTION 1</p>	 <p>3X 0.100 [2.54]      4X 0.026 [0.66] (SQUARE)</p> <p>0.300 [7.62]</p>	<p><b>Pin Connector</b> TYCO 3-640440-4</p> <p>Accepts wires: AWG #22</p>
 <p><b>Locking Connector</b></p>	 <p>1.150 [29.21]</p> <p>INPUT CONNECTOR OPTION 2</p>	 <p>3X 0.100 [2.54]      4X 0.026 [0.66] (SQUARE)</p> <p>0.120 [3.05]      0.200 [5.08]</p> <p>0.300 [7.62]      0.420 [10.67]</p> <p>0.500 [12.71]</p>	<p><b>Crimp Housing, Positive Latch</b> Molex 050579404</p> <p>Accepts wires: AWG #24, 0.2 mm<sup>2</sup></p>
 <p><b>Detachable Barriers w/Screws</b></p>	 <p>1.046 [26.58]      1.059 [26.90]</p> <p>INPUT CONNECTOR OPTION 3</p>	 <p>3X 0.138 [3.50]      0.413 [10.50]</p> <p>0.285 [7.25]      0.157 [4.00]</p> <p>0.122 [3.10]      4X 0.031 [0.80] (SQUARE)</p> <p>0.606 [15.40]</p>	<p><b>Vertical Plug, Top Wire entry</b> Molex 039500-0004 Phoenix 1840382 Dinkle EC350V-04P</p> <p><b>Vertical Plug, Rear Wire entry</b> Molex 39503-2004 Phoenix 1862878 Dinkle EC350RL-04P</p> <p><b>Vertical Plug, Front Wire entry</b> Molex 39503-3004 Phoenix 1863178 Dinkle EC350R-04P</p> <p><b>Vertical Spring Cage Plug, top Wire E</b> Phoenix 1939934 Dinkle 0221-2004</p> <p>All 4 options accept wires: AWG #16 to 24</p>
 <p><b>Direct Wire</b></p>	 <p>1.201 [30.50]</p> <p>INPUT CONNECTOR OPTION 4</p>	<p>N/A</p>	<p>Accepts wires: AWG #16 to 24</p>

### Accessories

- A large variety of **Heat Sinks** rated from .25 to 5.0 C/W specially engineered to match the heat dissipation requirements of Crydom SSRs.
- **Heat Transfer Pads** (Thermal Pads) for single, dual and 3 phase SSRs to maximize thermal conductivity.
- **Assemblies** of Crydom SSRs on Crydom heat sinks are also available.
- SSR mounting **Hardware Kits** (English and Metric threads).

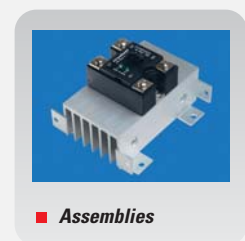

For more information about these and other accessories please ask your Crydom authorized distributor or visit [www.crydom.com/en/accessories](http://www.crydom.com/en/accessories)



## Dual Relays AC Output

25-40 Amp  
120/240/480 VAC

- 25A & 40A Output rating per channel
- 120/240 & 480VAC Operating voltage rating
- 4-15 & 15-32 VDC Control input options
- Internal output snubber standard
- SCR output for heavy industrial loads
- Industry standard panel mount package
- 0.25 inch Faston output connectors
- Zero voltage or random turn-on available
- CE & RoHS compliant, UL & cUL recognized & VDE approved\*

### OUTPUT SPECIFICATIONS<sup>Ⓞ</sup>

	D2425D D2425DE	D2440D D2440DE	H12D4825D H12D4825DE	H12D4840D H12D4840DE
Operating Voltage (47-63 Hz) [Vrms]	24-280	24-280	48-530	48-530
Transient Overvoltage [Vpk]	600	600	1200	1200
Maximum Off-State Leakage Current @ Rated Voltage [mA]	10	10	10	10
Minimum Off-State dv/dt @ Maximum Rated Voltage [V/μsec] <sup>Ⓜ</sup>	500	500	500	500
Maximum Load Current [Arms] <sup>Ⓝ</sup>	25	40	25	40
Minimum Load Current [Arms]	0.15	0.15	0.15	0.15
Maximum Surge Current (16.6ms) [Apk] @ 60 Hz	250	625	250	625
Maximum Surge Current (20.0ms) [Apk] @ 50 Hz	240	600	240	600
Maximum On-State Voltage Drop @ Rated Current [Vpk]	1.6	1.6	1.6	1.6
Thermal Resistance Junction to Case [Rjc] [°C/W]	1.02	0.63	1.02	0.63
Maximum I <sup>2</sup> t for Fusing (8.3 msec) [A <sup>2</sup> sec]	260	1620	260	1620
Maximum I <sup>2</sup> t for Fusing (10 msec) [A <sup>2</sup> sec]	285	1780	285	1780
Minimum Power Factor (with Maximum Load)	0.5	0.5	0.5	0.5

### INPUT SPECIFICATIONS<sup>Ⓞ</sup>

	D24XXD	H12D48XXD	DE-SUFFIX
Control Voltage Range [VDC]	4-15	4-15	15-32
Minimum Turn-On Voltage [VDC]	4.0	4.0	15.0
Minimum Turn-Off Voltage [VDC]	1.0	1.0	1.0
Typical Input Current @ 5 VDC (@ 24 VDC for E-Suffix) [mA]	13	13	15
Nominal Input Impedance [Ohm]	300	240	1500
Maximum Turn-On Time <sup>Ⓞ</sup>	1/2 cycle	1/2 cycle	1/2 cycle
Maximum Turn-Off Time	1/2 cycle	1/2 cycle	1/2 cycle

### GENERAL SPECIFICATIONS

Dielectric Strength 50/60 Hz Input/Output [Vrms]	4000
Dielectric Strength 50/60 Hz Input-Output/Baseplate [Vrms]	2500
Minimum Insulation Resistance (@ 500 V DC) [Ohm]	10 <sup>9</sup>
Maximum Capacitance, Input/Output [pF]	10
Ambient Operating Temperature Range [°C]	-40 to 80
Ambient Storage Temperature Range [°C]	-40 to 125
Weight (typical)	3.0 oz (86.5g)
Encapsulation	Thermally conductive Epoxy
Terminals (Output / Input)	0.25" Fastons / 0.025" Square Pins

\* D2425D & D2440D Models are also CSA approved.

Ⓞ All parameters at 25°C and per channel unless otherwise specified.

Ⓜ Off-State dv/dt test method per EIA/NARM standard RS-443, paragraph 13.11.1

Ⓝ Heat sinking required, see derating curves.

Ⓞ Turn-on time for random turn-on (-10) versions is 0.1msec.

### Part Number Nomenclature

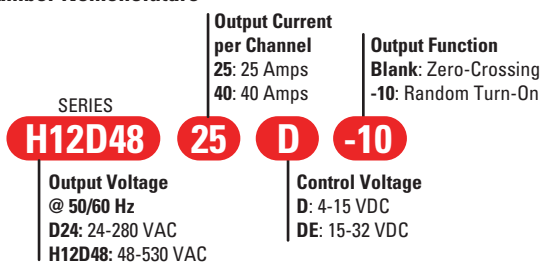

### Mechanical Dimensions

Tolerances: ± 0.02 in / 0.5 mm

All dimensions are in: inches [millimeters]

#### 120/240V Model

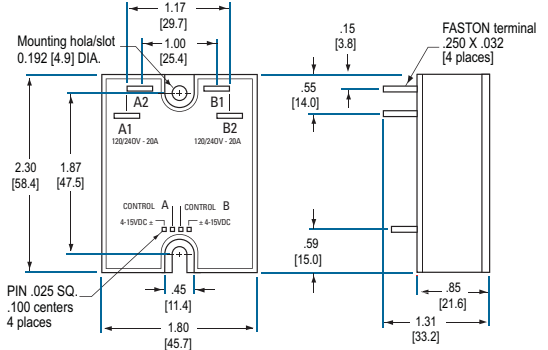

#### 480V Model

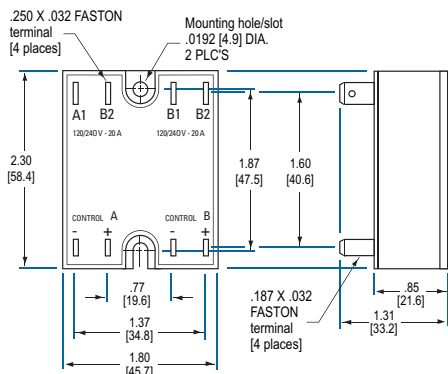

### Derating Curves

D2425XX, H12D4825XX  
(25 Amps per Channel)

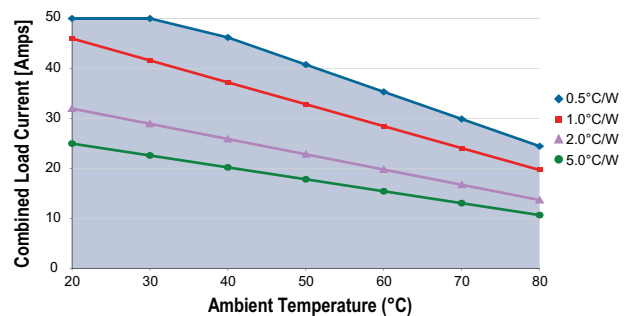

D2440XX, H12D4840XX  
(40 Amps per Channel)

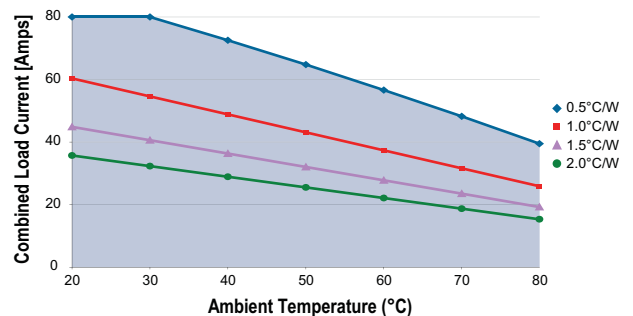

**crydom**<sup>®</sup>  
Across the Globe



**AMERICAS**

**USA & CANADA**

**Crydom Inc**  
2320 Paseo de las Americas,  
Suite 201  
San Diego CA 92154  
**Sales Support**  
Tel.: +1 (877) 502 5500  
Fax: +1 (619) 710 8540  
sales@crydom.com  
**Tech Support**  
Tel.: +1 (877) 702 7700  
support@crydom.com

**MEXICO**

**Automatismo Crouzet  
S.A. de C.V.**  
Calzada Zavaleta 2505 - C  
Col Sta Cruz Buenavista  
C.P. 72150 - Puebla  
MEXICO  
Tel. : +52 (222) 409 7000  
Fax : +52 (222) 409 7810  
01 800 087 6333  
sales-mx@crydom.com

**SOUTHERN AND  
CENTRAL AMERICAN  
COUNTRIES**

**CST Latinoamerica**  
Alameda Rio Negro, 1.084-cj.A31  
Centro Empresarial de Alphaville  
CEP: 06454-000  
Barueri - SP  
BRASIL  
Tel.: +55 (11) 4191 9797  
Fax: +55 (11) 4191 9136  
info@cst-latinoamerica.com

**EUROPE  
MIDDLE EAST  
AFRICA**

**UNITED KINGDOM**

**Crydom SSR Ltd**  
Arena Business Centre  
Holyrood, Close  
Poole, Dorset BH17 7FJ  
**Sales Support**  
Tel.: +44 (0) 1202 606030  
Fax: +44 (0) 1202 606035  
sales-europe@crydom.com  
**Tech Support**  
tech-europe@crydom.com

**AUSTRIA & SWITZERLAND**

Tel.: +44 (0) 1202 606030  
Fax: +44 (0) 1202 606035  
vertrieb@crydom.com

**GERMANY**

Tel.: +49 (0) 180 3000 506  
Fax: +49 (0) 180 3205 227  
vertrieb@crydom.com

**BELGIUM**

Tel.: +32 (0) 2 460 4413  
Fax: +32 (0) 2 461 2614  
sales-europe@crydom.com

**FRANCE**

**N°Azur 0 810 123 963**  
PREMIER APPEL LOCAL  
**N°Azur Fax 0 810 057 605**  
PREMIER APPEL LOCAL  
sales-europe@crydom.com

**ITALY**

Tel.: +39 (0) 2 665 99 260  
Fax: +39 (0) 2 665 99 268  
sales-europe@crydom.com

**THE NETHERLANDS**

Tel.: +31 (0) 71 582 0068  
Fax: +31 (0) 71 542 1648  
sales-europe@crydom.com

**SPAIN**

Tel.: +34 902 876 217  
Fax: +34 902 876 219  
sales-europe@crydom.com

**MIDDLE EAST,  
AFRICA AND OTHER  
EUROPEAN COUNTRIES**

Tel.: +44 (0) 1202 606030  
Fax: +44 (0) 1202 606035  
sales-europe@crydom.com

**ASIA  
PACIFIC**

**CHINA & HONG KONG**

**Custom Sensors &  
Technologies Asia  
(Shanghai) Ltd.**  
2 Floor, Innovation Building,  
No.1009, Yi Shan Road,  
Shanghai, 200233  
Tel.: +86 (21) 2401 7766  
Fax: +86 (21) 6249 0701  
sales-cn@crydom.com

**TAIWAN**

**Custom Sensors &  
Technologies**  
3F, No. 39, Ji-Hu Road  
Nei-Hu Dist.  
Taipei 114, Taiwan  
Tel.: +886 2 8751 6388  
Fax: +886 2 2657 8725  
taiwan@cstsensors.com

**SOUTH KOREA**

**Custom Sensors &  
Technologies**  
5F, Jeil Bldg.,  
94-46 Youngdeungpo-dong 7-ga  
Youngdeungpo-gu,  
Seoul, 150-037  
South Korea  
Tel.: +82 2 2629 8312  
Fax: +82 2 2629 8310  
korea@cstsensors.com

**INDIA**

**CST Sensors India Pvt Ltd**  
Unit 1301 and 1302 Prestige  
Meridian II  
30 M.G.Road,  
Bangalore - 560001  
INDIA  
Tel.: +91 (80) 4113 2204/05  
Fax: +91 (80) 4113 2206  
india@cstsensors.com

**OTHER ASIAN AND  
PACIFIC COUNTRIES**

**Custom Sensors &  
Technologies**  
3F, No. 39, Ji-Hu Road  
Nei-Hu Dist.  
Taipei 114, Taiwan  
Tel.: +886 2 8751 6388  
Fax: +886 2 2657 8725  
eap@cstsensors.com

CAT/CR/ED/EN

Distributed by :

© 2009 Crydom Inc., All Rights Reserved.

Specifications are subject to change without prior notice.  
Crydom and the Crydom logo are registered trademarks  
of Crydom Inc.