

5.0x7.0mm Surface Mount CMOS Clock Oscillator Series

CONNOR WINFIELD



Models CWX813 and CWX823 in Stock at Digi-Key

Description

The Connor-Winfield CWX8xx - series is a RoHS compliant 5x7.5mm Surface Mount, Fixed Frequency Crystal Controlled Oscillator (XO). Designed for use in applications requiring tight frequency stability and low jitter. The surface mount package is designed for high-density mounting and is optimum for mass production.



Features

Model CWX8xx - Series

5.0 x7.0mm Surface Mount Package
3.3V or 5.0V Operation
CMOS Output Logic
Frequency Stabilities Available:
+/-25ppm or +/-50ppm
Temperature Range: -20 to 70°C
Low Jitter <1pS RMS
Tri-State Enable/Disable
Tape and Reel Packaging ✓RoHS

2111 Comprehensive Drive
Aurora, Illinois 60505
Phone: 630-851-4722
Fax: 630-851-5040
www.conwin.com
US Headquarters:
630-851-4722
European Headquarters:
+353-61-472221

Absolute Maximum Rating

Parameter	Units	Minimum	Nominal	Maximum	Units	Note
Storage Temperature		-55	-	125	°C	
Supply Voltage (Vcc=3.3Vdc)	(Vcc)	-0.5	-	5.0	Vdc	
Supply Voltage (Vcc=5.0Vdc)	(Vcc)	-0.5	-	7.0	Vdc	
Input Voltage		-0.5	-	Vcc+0.5	Vdc	

Operating Specifications

Parameter	Units	Minimum	Nominal	Maximum	Units	Note
Frequency Range	(Fo)	1.0	-	156.25	MHz	
Total Frequency Tolerance						
Models CWX813-CWX815		-25	-	25	ppm	1
Models CWX823-CWX825		-50	-	50	ppm	1
Operating Temperature Range		-20	-	70	°C	
Supply Voltage	(Vcc)					
Models CWX813-CWX823		3.135	3.3	3.465	Vdc	
Models CWX815-CWX825		4.5	5.0	5.5	Vdc	
Supply Current	(Icc)					
Models CWX813-CWX823 (Vcc = 3.3Vdc)		-	-	30	mA	
Models CWX815-CWX825 (Vcc = 5.0Vdc)		-	-	45	mA	

Input Characteristics

Parameter	Units	Minimum	Nominal	Maximum	Units	Note
Enable Voltage	(High) (Vih)	2.2	-	-	Vdc	2
Disable Voltage	(Low) (Vil)	-	-	0.8	Vdc	2

Output Characteristics

Parameter	Units	Minimum	Nominal	Maximum	Units	Note
Load						
Models CWX813-CWX823 (LVCMOS)		-	15	-	pF	
Models CWX815-CWX825 (HCMOS)		-	-	50	pF	
Voltage (High)	(Voh)	Vcc-0.4	-	-	Vdc	
(Low)	(Vol)	-	-	0.4	Vdc	
Current (High)	(Ioh)	-8	-	-	mA	
(Low)	(Ioh)	-	-	8	mA	
Duty Cycle at 50% of Vcc		40	50	60	%	
Rise / Fall Time 10% to 90%		-	2	6	ns	
Start-Up Time		-	-	10	ms	
Period Jitter		-	3	5	ps RMS	
Phase Jitter (BW=12kHz to 20MHz)		-	0.5	1	ps RMS	
SSB Phase Noise at 10Hz offset		-	-60	-	dBc/Hz	
SSB Phase Noise at 100Hz offset		-	-90	-	dBc/Hz	
SSB Phase Noise at 1KHz offset		-	-125	-	dBc/Hz	
SSB Phase Noise at 10KHz offset		-	-140	-	dBc/Hz	
SSB Phase Noise at 100KHz offset		-	-145	-	dBc/Hz	

Package Characteristics

Package	Hermetically sealed ceramic package
Soldering Process	RoHS compliant, lead free. See solder profile on page 2.

Notes

- Inclusive of calibration @ 25°C, frequency vs. temperature stability, supply voltage change, load change, shock and vibration, 10 years aging.
- When the oscillator is disabled, the outputs are at high impedance. Output is enabled with no connection on pad 1.

Specifications subject to change without notice. All dimensions in inches. © Copyright 2008 The Connor-Winfield Corporation



Bulletin **Sm126**
Page **1 of 2**
Revision **01**
Date **13 May 2009**

Ordering Information

CWX	8	1	3	16.384M
Type: Clock Series 5x7mm	Temperature Range: 8 = -20 to 70° C	Frequency Stability: 1 = +/-25 ppm 2 = +/-50 ppm	Supply Voltage: 3 = 3.3Vdc. 5 = 5.0Vdc.	Output Frequency: Frequency Format -xxx.xM Min.* -xxx.xxxxxM Max.* *Amount of numbers after the decimal point. M = MHz

Example: CWX813-016.384M = LVCMOS Clock, -20 to 70°C, ±25ppm, 3.3V @ 16.384 MHz

Environmental Characteristics

Vibration:	Vibration per Mil Std 883E Method 2007.3 Test Condition A
Shock:	Mechanical Shock per Mil Std 883E Method 2002.4 Test Condition B.
Soldering:	SMD product suitable for Convection Reflow soldering. Peak temperature 260°C. Maximum time above 220°C, 60 seconds.
Solderability	Solderability per Mil Std 883E Method 2003

Pad Connections and Enable / Disable Function

Pad	Connection	Enable / Disable Function (Pad 1)	Output
1	Enable/Disable	High or Open	Enable
2	Ground	Low	Disable (High Impedance)
3	Output		
4	Vcc		

Package Outline

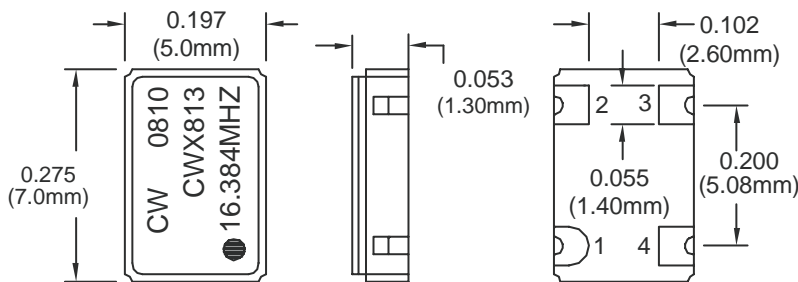

Dimensional Tolerance: ± .008" (±0.2mm)

Tape and Reel Dimensions

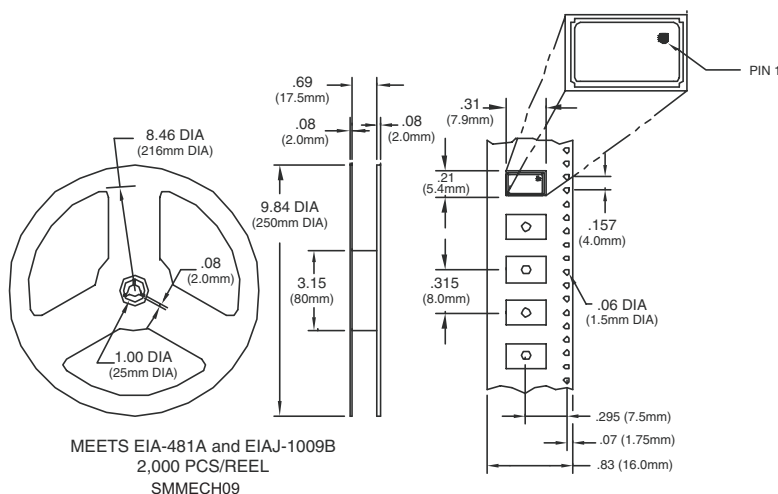

MEETS EIA-481A and EIAJ-1009B
2,000 PCS/REEL
SMMECH09

Test Circuit

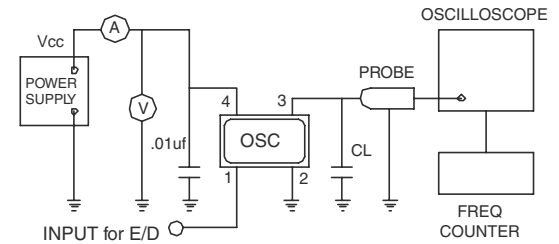

Output Waveform

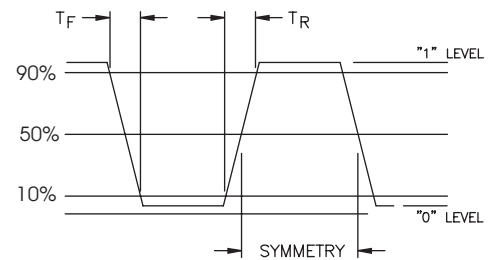

Suggested Pad Layout

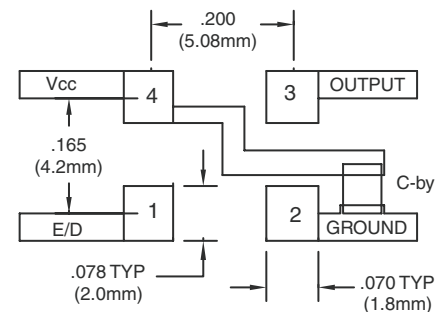

Bypass capacitor: C-by should be ceramic capacitor ≥ .01uf.

Solder Profile

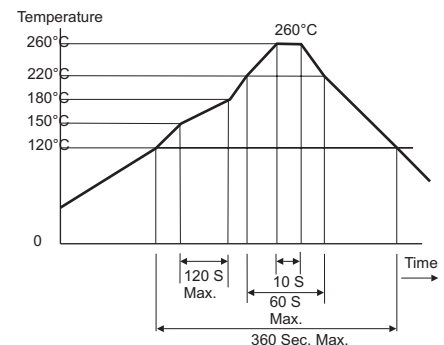

US Headquarters:
630-851-4722
European Headquarters:
+353-61-472221

Bulletin SM126
Page 2 of 2
Revision 01
Date 13 May 2009