



Common Mode Choke ~CMT1205B SERIES



RoHS Compliant

PART NUMBERING SYSTEM

<u>CMT</u>	<u>1205B</u>	—	<u>102N</u>	—	<u>LF</u>
TYPE	DIMENSIONS		IMPEDANCE		LEAD FREE

SHAPES AND DIMENSIONS

UNIT : mm

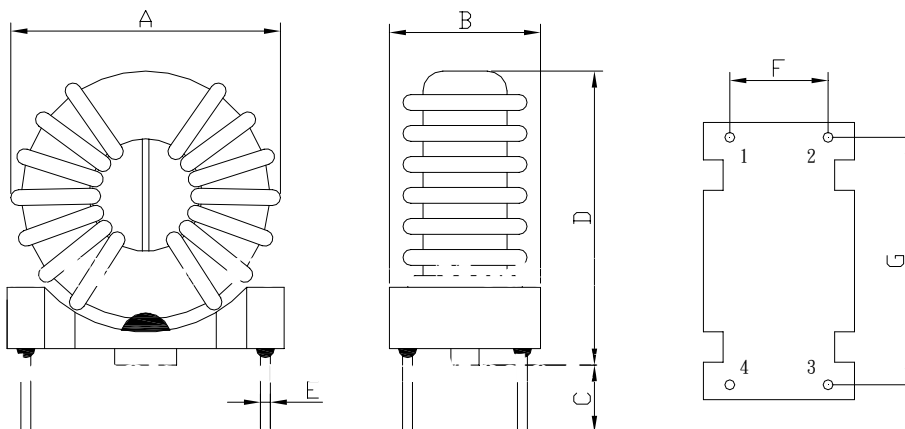

A=15.0 Max. B=7.5 Max. C=2.5±0.5 D=18.0 Max. E=0.7 Ref. F=4.5±0.5 G=10.0±0.5

SCHEMATIC DRAWING

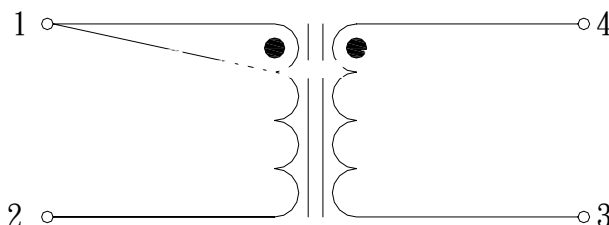



Common Mode Choke ~CMT1205B SERIES



RoHS Compliant

SPECIFICATION TABLE

PART NUMBER	INDUCTANCE (mH)	DCR (mΩ) (max)	IDC (A) (max)	NOMINAL VOLTAGE VAC	TEST FREQ. (f)
CMT1205B-102N-LF	1.0±30%	45	2.0	250	1KHz
CMT1205B-402N-LF	4.0±30%	140	1.5	250	1KHz
CMT1205B-502N-LF	5.0±30%	200	1.0	250	1KHz
CMT1205B-103N-LF	10.0±30%	350	0.7	250	1KHz
CMT1205B-203N-LF	20.0±30%	1000	0.5	250	1KHz
CMT1205B-393N-LF	39.0±30%	3000	0.3	250	1KHz

- Inductance is measured with a LCR meter 4284A or equivalent.
- Test voltage : 1500V, 50Hz , 5mA , 2sec.
- Operating temperature range -40°C to +125°C
- Electrical specifications at 25°C