

All Dimensions in mm.

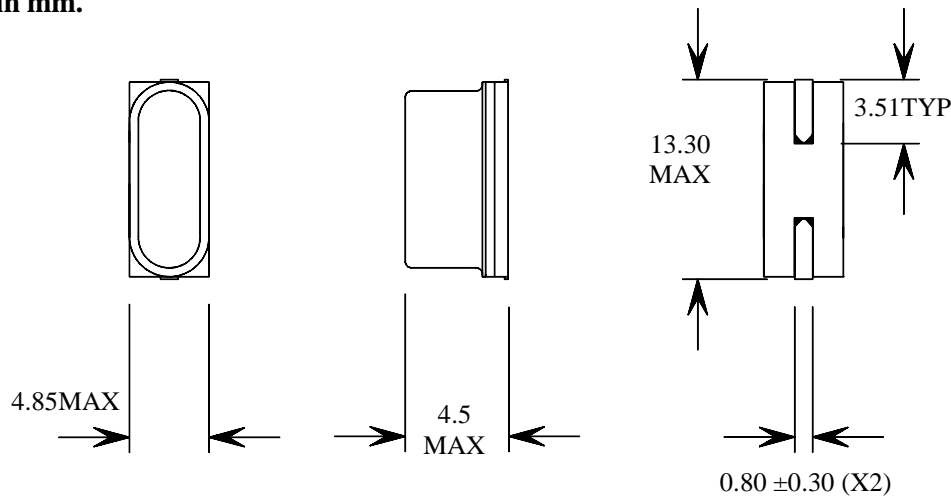

Marking Guide

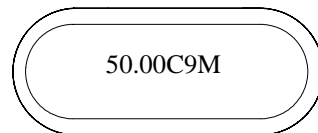

50.00 = 50.000MHz
 C = Caliber Electronics Inc.
 8M = Mfg. Date Code (Year / Month)

Electrical Specifications	
Frequency Range	2.500MHz to 125.000MHz
Frequency Tolerance/Stability	Other Combinations Available. Contact Factory for Custom Specifications.
“A” Option	±50/100ppm Max.
“B” Option	±30/50ppm Max.
“C” Option	±15/30ppm Max.
“D” Option	±15/25ppm Max.
“E” Option	±15/15ppm Max.
“F” Option	±10/25ppm Max.
“G” Option	±20/30ppm Max.
Operating Temperature Range	
“C” Option	0°C to 70°C
“E” Option	-20°C to 70°C
“F” Option	-40°C to 85°C (A, B, C option only)
Storage Temperature Range	-55°C to 125°C
Load Capacitance	
“S” Option	Series
“XX” Option	10pF to 32pF
Mode of Operation	
Fundamental “1” Option	2.500MHz to 40.000MHz
Third Overtone “3” Option	28.000MHz to 75.000MHz
Fifth Overtone “5” Option	60.000MHz to 125.000MHz
Drive Level	1 mWatt Maximum, 100 uWatts Correlation

Solder Reflow Guide

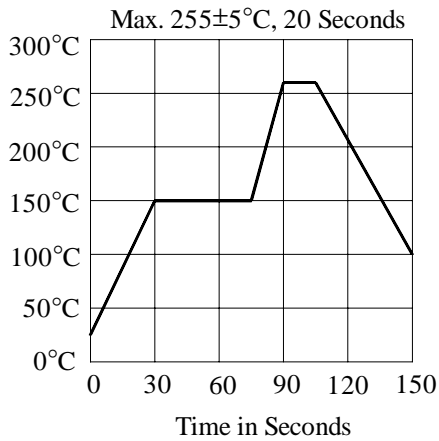

Suggested Solder Pad Layout

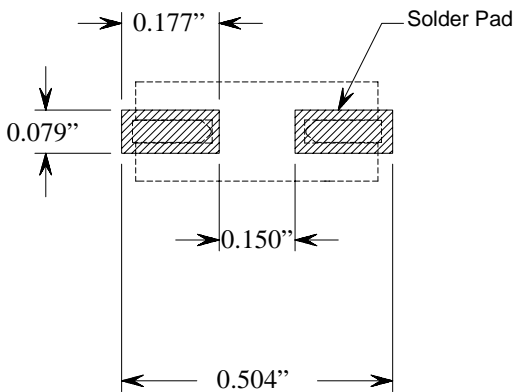

Part Numbering Guide

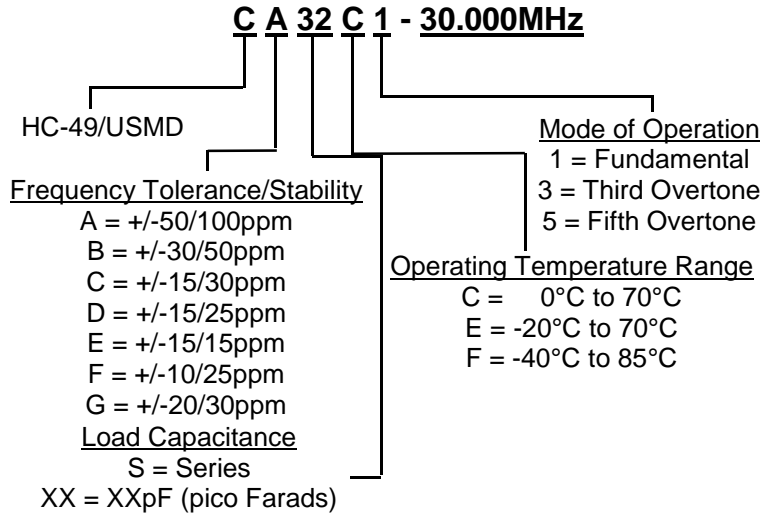

Theoretical Frequency vs. Temperature Curves of AT and BT Cut Crystals

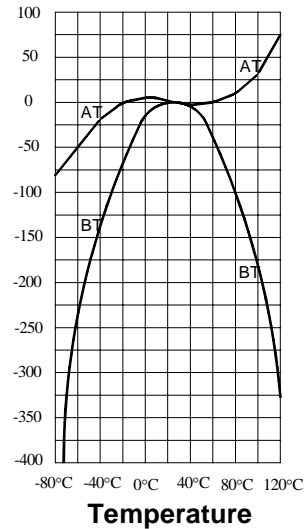

Equivalent Series Resistance Versus Frequency

Frequency in MHZ	Maximum ESR	Frequency in MHZ	Maximum ESR
2.5000 to 3.8000	150	8.0100 to 10.0000	60
3.8100 to 4.1000	120	10.0100 to 12.0000	50
4.1100 to 5.0000	100	12.0100 to 26.0000	40
5.0100 to 6.0000	80	28.0000 to 75.0000 Third Overtone	60
6.0100 to 8.0000	70	60.0000 to 125.000 Fifth Overtone	80

Environmental and Mechanical Specifications

- Shock: MIL-STD-883C, Method 2002, Condition B
- Solderability: MIL-STD-883C, Method 2003.3
- Vibration: MIL-STD-883C, Method 2007, Condition A
- Fine Leak: MIL-STD-883C, Method 1014.5, Condition A2, 5×10^{-8} ATM cc/sec
- Gross Leak: MIL-STD-883C, Method 1014.5, Condition C
- Resistance to Solvents: MIL-STD-202F, Method 215B