

*ROHS COMPLIANT

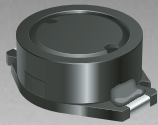

BOURNS®

Features

- Available in E12 series
- Unit height of 5.2 mm
- Current up to 4.5 A
- Lead free
- RoHS compliant*

Applications

- Input/output of DC/DC converters
- Power supplies for:
 - Portable communication equipment
 - Camcorders
 - LCD TVs
 - Car radios

SRR1005 Series - Shielded Power Inductors

Electrical Specifications

Bourns Part No.	Inductance 1kHz		Q Ref.	Test Frequency (MHz)	SRF Min. (MHz)	RDC (Ω)	I rms Max. (A)	I sat Typ. (A)
	(μH)	Tol. %						
SRR1005-1R0M	1.0	± 20	25	7.96M	120	0.017	4.50	8.00
SRR1005-1R5M	1.5	± 20	25	7.96M	100	0.020	3.60	7.00
SRR1005-2R2M	2.2	± 20	25	7.96M	90.0	0.027	3.10	6.10
SRR1005-3R0M	3.0	± 20	25	7.96M	80.0	0.030	2.90	5.00
SRR1005-4R7M	4.7	± 20	25	7.96M	50.0	0.040	2.50	3.80
SRR1005-7R0M	7.0	± 20	22	7.96M	32.0	0.055	2.20	3.20
SRR1005-100M	10	± 20	48	2.52M	30.0	0.065	2.00	3.00
SRR1005-120M	12	± 20	45	2.52M	25.0	0.080	1.80	2.30
SRR1005-150M	15	± 20	40	2.52M	20.0	0.085	1.70	2.10
SRR1005-180Y	18	± 15	35	2.52M	19.0	0.090	1.60	2.10
SRR1005-220Y	22	± 15	42	2.52M	18.0	0.100	1.40	1.90
SRR1005-270Y	27	± 15	40	2.52M	17.0	0.120	1.30	1.60
SRR1005-330Y	33	± 15	40	2.52M	15.0	0.160	1.20	1.56
SRR1005-390Y	39	± 15	40	2.52M	13.0	0.180	1.05	1.40
SRR1005-470Y	47	± 15	35	2.52M	12.0	0.190	1.00	1.30
SRR1005-560Y	56	± 15	35	2.52M	11.0	0.210	0.90	1.10
SRR1005-680Y	68	± 15	35	2.52M	9.0	0.340	0.82	1.10
SRR1005-820Y	82	± 15	35	2.52M	8.0	0.380	0.75	0.95
SRR1005-101K	100	± 10	35	0.796M	7.5	0.420	0.68	0.90
SRR1005-121K	120	± 10	30	0.796M	7.2	0.460	0.60	0.80
SRR1005-151K	150	± 10	28	0.796M	6.2	0.520	0.55	0.66
SRR1005-181K	180	± 10	28	0.796M	5.8	0.700	0.50	0.65
SRR1005-221K	220	± 10	30	0.796M	5.2	0.800	0.45	0.63
SRR1005-271K	270	± 10	30	0.796M	4.8	1.100	0.40	0.52
SRR1005-331K	330	± 10	30	0.796M	4.5	1.200	0.35	0.48
SRR1005-391K	390	± 10	25	0.796M	4.2	1.400	0.33	0.45
SRR1005-471K	470	± 15	40	0.796M	3.0	1.600	0.30	0.45
SRR1005-561K	560	± 10	40	0.796M	2.7	1.800	0.28	0.42
SRR1005-681K	680	± 10	37	0.796M	2.6	2.300	0.26	0.38
SRR1005-821K	820	± 10	37	0.796M	2.5	2.600	0.24	0.36
SRR1005-102K	1000	± 10	65	0.252M	2.0	3.200	0.22	0.32
SRR1005-122K	1200	± 10	58	0.252M	2.0	3.600	0.20	0.29
SRR1005-152K	1500	± 10	53	0.252M	1.6	5.200	0.17	0.24
SRR1005-182K	1800	± 10	65	0.252M	1.4	5.700	0.16	0.23
SRR1005-222K	2200	± 10	55	0.252M	1.4	6.500	0.14	0.21
SRR1005-272K	2700	± 10	55	0.252M	1.2	8.600	0.12	0.18
SRR1005-332K	3300	± 10	50	0.252M	1.2	10.00	0.10	0.17

General Specifications

Test Voltage 1 V
 Reflow Soldering....230 °C, 10 sec. max.
 Operating Temperature...-40 °C to +125 °C
 (Temperature rise included)
 Storage Temperature...-40 °C to +125 °C
 Resistance to Soldering Heat
230 °C for 10 sec.

Materials

CoreFerrite DR and RI core
 WireEnameled copper
 BaseLCP E4008
 TerminalCu/Ni/Sn
 Rated Current
Ind. drop 10 % typ. at Isat
 Temperature Rise
40 °C max. at rated Irms
 Packaging.....600 pcs. per reel

Product Dimensions

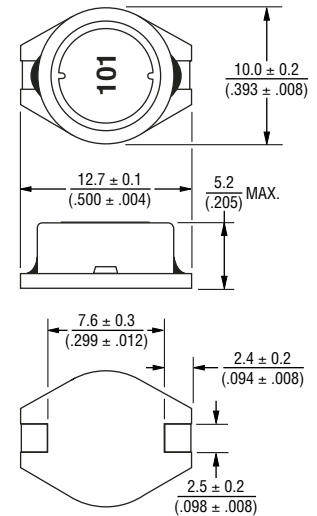

Recommended Layout

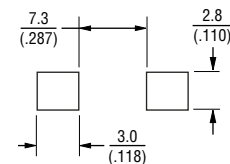

DIMENSIONS: $\frac{\text{MM}}{\text{(INCHES)}}$

*RoHS Directive 2002/95/EC Jan 27 2003 including Annex
 Specifications are subject to change without notice.
 Customers should verify actual device performance in their specific applications.

SRR1005 Series - Shielded Power Inductors

BOURNS®

Soldering Profile

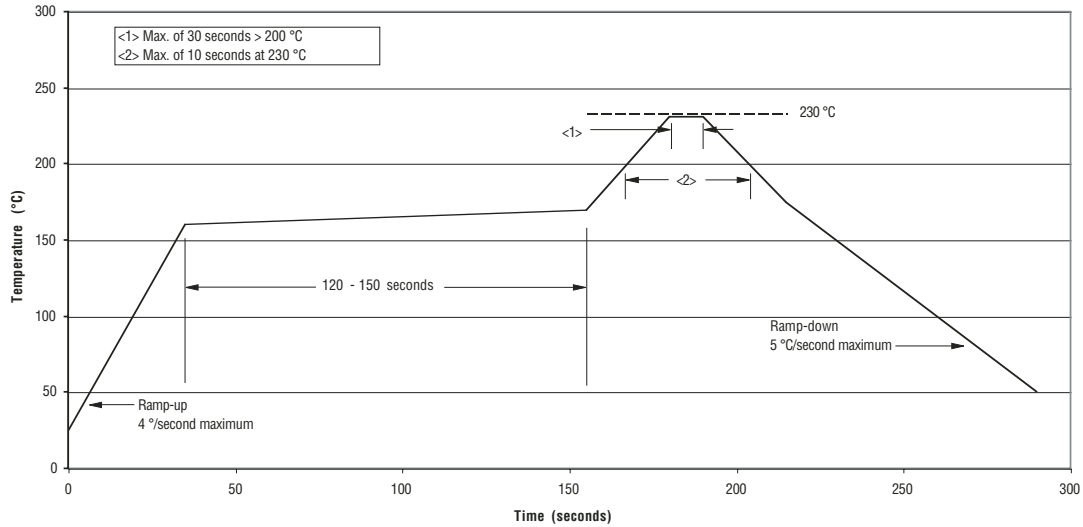

Packaging Specifications

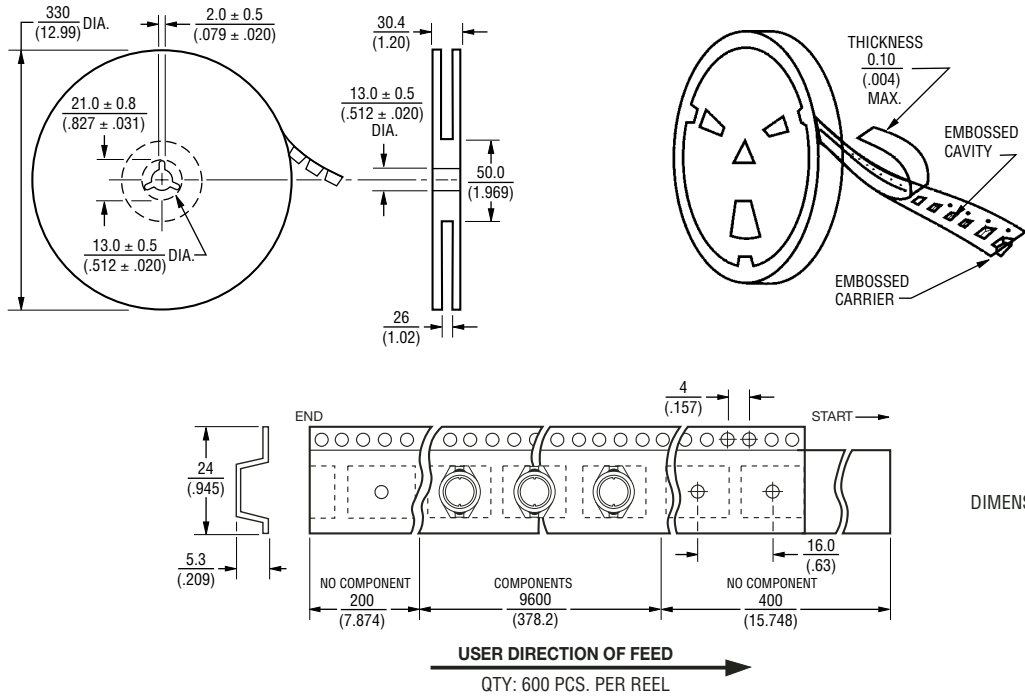

REV. 02/05

Specifications are subject to change without notice.
Customers should verify actual device performance in their specific applications.