

*RoHS COMPLIANT

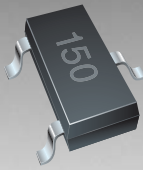

BOURNS®

Features

- RoHS Compliant*
- Low capacitance - 2.5 pF
- ESD protection
- Surge protection

Applications

- Personal Digital Assistants (PDAs)
- Mobile phones & accessories
- Memory card protection
- SIM card port protection
- Portable electronics

CDSOT23-SLVU2.8 – Surface Mount TVS Diode

General Information

The CDSOT23-SLVU2.8 device provides ESD, EFT and Surge protection for high speed data ports meeting IEC 61000-4-2 (ESD), IEC 61000-4-4 (EFT) and IEC 61000-4-5 (Surge) requirements. The Transient Voltage Suppressor Array offers a Working Peak Reverse Voltage of 2.8 V and Minimum Breakdown Voltage of 3 V.

The SOT23 packaged device will mount directly onto the industry standard SOT23 footprint. Bourns® Chip Diodes conform to JEDEC standards, are easy to handle with standard pick and place equipment and the flat configuration minimizes roll away.

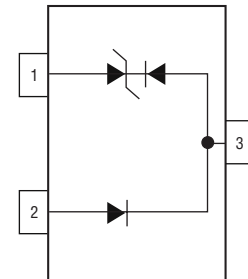

Electrical Characteristics (@ T_A = 25 °C Unless Otherwise Noted)

Parameter	Symbol	Value	Unit
Peak Pulse Power ($t_p = 8/20 \mu s$) ¹	P _{PK}	600	W
Peak Pulse Current ($t_p = 8/20 \mu s$)	I _{PPM}	30	A
Storage Temperature	T _{STG}	-55 to +150	°C
Operating Temperature	T _{OPR}	-55 to +150	°C
Minimum Breakdown Voltage @ 1 mA	V _{BR}	3.0	V
Minimum Snap Back Voltage @ 50 mA	V _{BR}	2.8	V
Maximum Working Peak Voltage	V _{WM}	2.8	V
Maximum Leakage Current @ V _{WM} (Pin 3 to Pin 1) or (Pin 2 to Pin 1)	I _D	1.0	μA
Maximum Clamping Voltage @ I _P = 2 A	V _C	5.5	V
Maximum Clamping Voltage @ I _P = 5 A (Pin 2 to in 1)	V _C	7.0 8.5	V
Maximum Clamping Voltage @ I _P = 30 A	V _C	21.0	V
Typical Junction Capacitance @ 0 V, 1 MHz (Pin 3 to Pin 1 & Pin 2) (Pin 2 to Pin 1 with Pin 3 NC)	C _D	20 2.5	pF
Maximum Junction Capacitance @ 0 V, 1 MHz	C _D	3	pF
Maximum Peak Reverse Voltage @ I = 10 μA	V _{RRM}	40	V
Maximum Reverse Leakage Current @ V _{WM}	I _{DR}	0.1	μA
Maximum Forward Voltage @ I _F = 1 A, 120 μS	V _F	2	V

Note:

1. See Peak Pulse Power vs. Pulse Time.

*RoHS Directive 2002/95/EC Jan 27 2003 including Annex.

Specifications are subject to change without notice.

Customers should verify actual device performance in their specific applications.

CDSOT23-SLVU2.8 – Surface Mount TVS Diode



Product Dimensions

This is a molded JEDEC SOT-23 package with 100 % Matte Sn plating on the lead frame. It weighs approximately 8 mg and has a flammability rating of UL 94V-0.

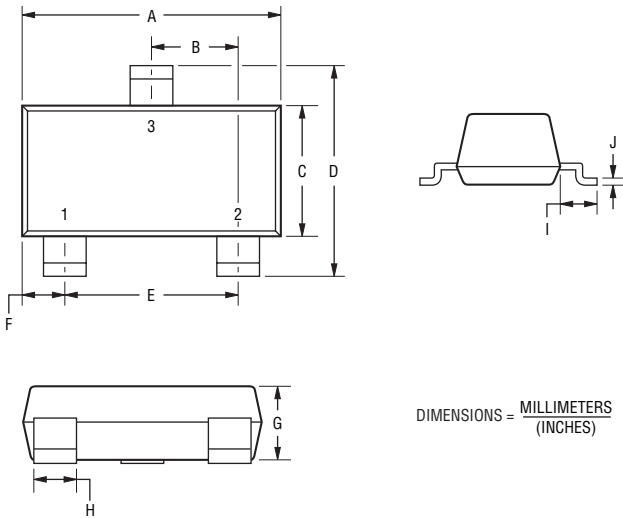

DIMENSIONS = $\frac{\text{MILLIMETERS}}{\text{(INCHES)}}$

Dimensions	
A	$\frac{2.80 - 3.04}{(0.1102 - 0.1197)}$
B	$\frac{0.89 - 1.02}{(0.0350 - 0.0401)}$
C	$\frac{1.20 - 1.40}{(0.0472 - 0.0551)}$
D	$\frac{2.10 - 2.50}{(0.0830 - 0.0984)}$
E	$\frac{1.78 - 2.04}{(0.0701 - 0.0807)}$
F	$\frac{0.45 - 0.60}{(0.0177 - 0.0236)}$
G	$\frac{0.89 - 1.11}{(0.035 - 0.044)}$
H	$\frac{0.34 - 0.50}{(0.0150 - 0.0200)}$
I	$\frac{0.45 - 0.60}{(0.0180 - 0.0236)}$
J	$\frac{0.085 - 0.177}{(0.0034 - 0.0070)}$

Recommended Footprint

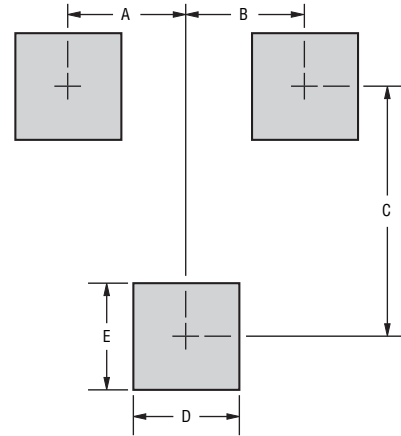

DIMENSIONS = $\frac{\text{MILLIMETERS}}{\text{(INCHES)}}$

Dimensions	
A	$\frac{0.95}{(0.037)}$
B	$\frac{0.95}{(0.037)}$
C	$\frac{2.00}{(0.079)}$
D	$\frac{0.85}{(0.033)}$
E	$\frac{0.85}{(0.033)}$

How To Order

CD S0T23 - SLVU 2.8

Common Code _____
 Chip Diode _____
 Package _____
 • S0T23 = S0T23 Package
 Model _____
 SLVU = Special Model
 Working Peak Reverse Voltage _____
 2.8 = 2.8 V_{RWM} (Volts)

Typical Part Marking

CDSOT23-SLVU2.8..... SLA

Performance Graphs

Peak Pulse Power vs Pulse Time

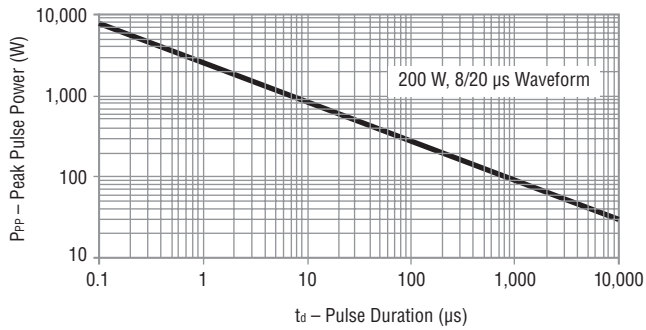

Pulse Waveform

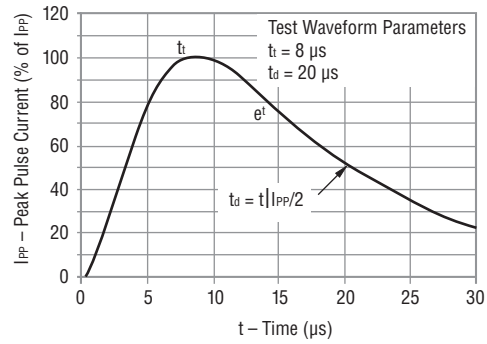

Overshoot & Clamping Voltage

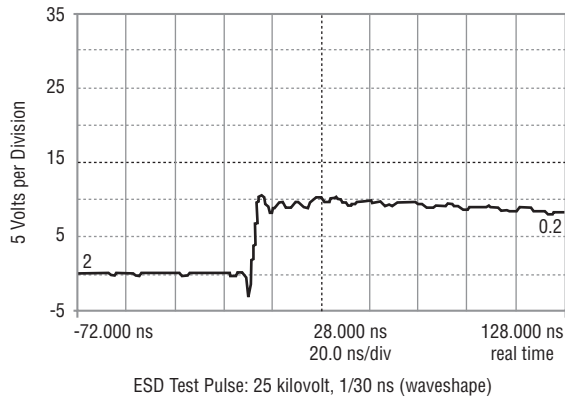

Power Derating Curve

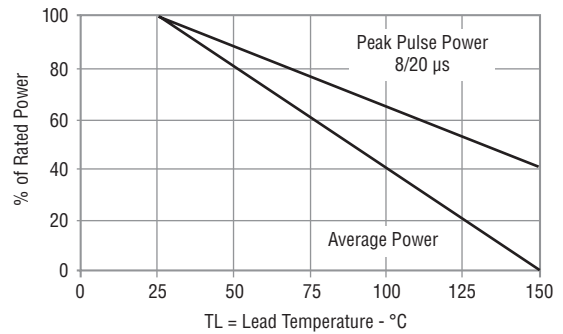

CDSOT23-SLVU2.8 – Surface Mount TVS Diode

BOURNS®

Packaging Information

The product is packaged in an 8 mm x 4 mm tape and reel format per EIA-481-A standard.

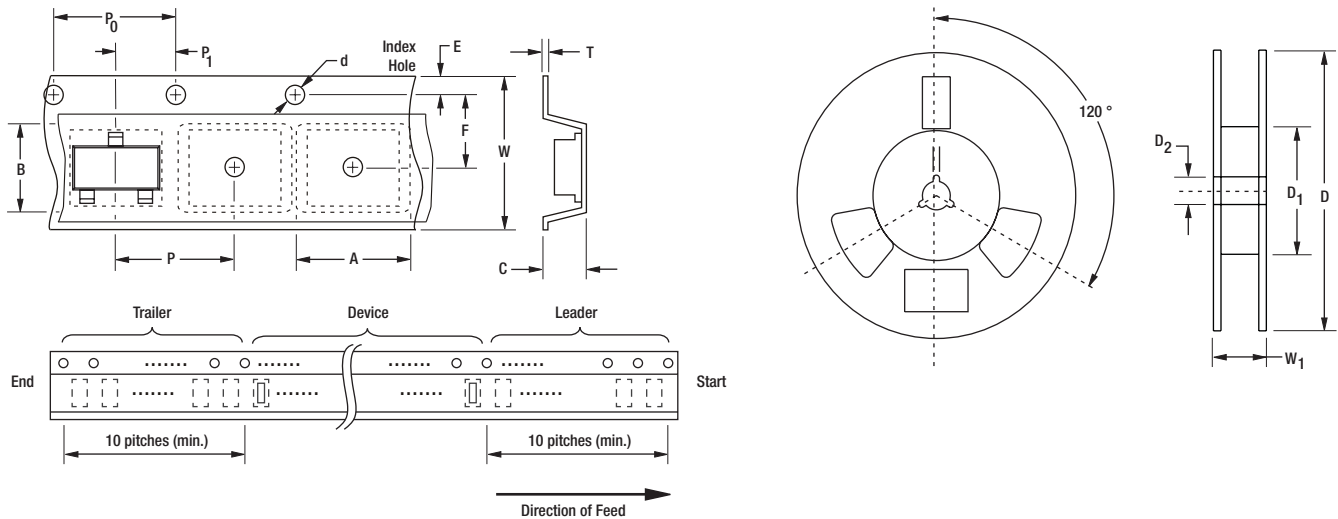

Item	Symbol	SOT23
Carrier Width	A	$\frac{2.25 \pm 0.10}{(0.088 - 0.004)}$
Carrier Length	B	$\frac{2.34 \pm 0.10}{(0.092 - 0.004)}$
Carrier Depth	C	$\frac{1.22 \pm 0.10}{(0.048 - 0.004)}$
Sprocket Hole	d	$\frac{1.55 \pm 0.05}{(0.061 - 0.002)}$
Reel Outside Diameter	D	$\frac{178}{(7.008)}$
Reel Inner Diameter	D ₁	$\frac{50.0}{(1.969)}$ Min.
Feed Hole Diameter	D ₂	$\frac{13.0 \pm 0.20}{(0.512 - 0.008)}$
Sprocket Hole Position	E	$\frac{1.75 \pm 0.10}{(0.069 - 0.004)}$
Punch Hole Position	F	$\frac{3.50 \pm 0.05}{(0.138 - 0.002)}$
Punch Hole Pitch	P	$\frac{4.00 \pm 0.10}{(0.157 - 0.004)}$
Sprocket Hole Pitch	P ₀	$\frac{4.00 \pm 0.10}{(0.157 - 0.004)}$
Embossment Center	P ₁	$\frac{2.00 \pm 0.05}{(0.079 - 0.002)}$
Overall Tape Thickness	T	$\frac{0.20 \pm 0.10}{(0.008 - 0.004)}$
Tape Width	W	$\frac{8.00 \pm 0.20}{(0.315 - 0.008)}$
Reel Width	W ₁	$\frac{14.4}{(0.567)}$ Max.
Quantity per Reel	—	3,000



Asia-Pacific:

Tel: +886-2 2562-4117 • Fax: +886-2 2562-4116

Europe:

Tel: +41-41 768 5555 • Fax: +41-41 768 5510

The Americas:

Tel: +1-951 781-5500 • Fax: +1-951 781-5700

www.bourns.com

REV. 04/10

Specifications are subject to change without notice.
Customers should verify actual device performance in their specific applications.