

GENERAL INFORMATION

AVX SR Series

Conformally Coated Radial Ledged MLC

Temperature Coefficients: C0G (NP0), X7R, Z5U

200, 100, 50 Volts (300V, 400V & 500V also available)

Case Material: Epoxy

Lead Material: Solderable

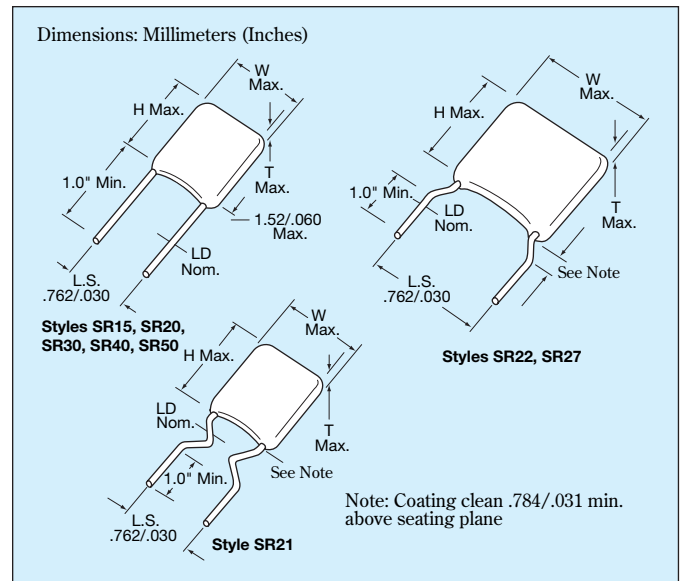

HOW TO ORDER

SR21	5	E	104	M	A	R
AVX Style	Voltage	Temperature Coefficient	Capacitance	Capacitance Tolerance	Failure Rate	Leads
SR15 SR20 SR21 SR22 SR27 SR30 SR40 SR50	5 = 50V 1 = 100V 2 = 200V 9 = 300V 8 = 400V 7 = 500V	A = C0G (NP0) C = X7R E = Z5U	First two digits are the significant figures of capacitance. Third digit indicates the additional number of zeros. For example, order 100,000 pF as 104. (For values below 10pF use "R" in place of decimal point, e.g., 1R4 = 1.4pF.)	COG (NP0): C = ±.25pF D = ±.5pF F = ±1% (>50pF only) G = ±2% (>25pF only) J = ±5% K = ±10%	X7R: J = ±5% K = ±10% M = ±20% Z5U: M = ±20% Z = +80% -20%	A = Not Applicable T = Trimmed Leads .230" ± .030" A = Long Leads 1.0" minimum (Other lead lengths are available, contact AVX) R = RoHS Long Lead 1.0" minimum

MARKING

FRONT

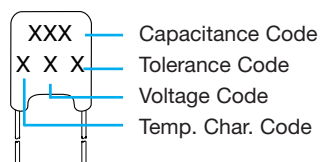

BACK

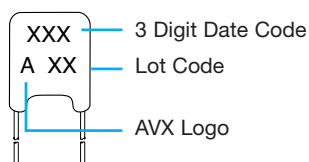

PACKAGING REQUIREMENTS

	Quantity per Bag
SR15, 20, 21, 22, 27, 30	1000 Pieces
SR40, 50	500 Pieces

Note: SR15, SR20, SR21, SR30, and SR40 available on tape and reel per EIA specifications RS-468. See Pages 29 and 30.

SIZE AND CAPACITANCE SPECIFICATIONS

EIA Characteristic		Dimensions: Millimeters (Inches)																					
AVX Style		SR15	SR20	SR21	SR22	SR27	SR30	SR40	SR50														
AVX "Insertable"		SR07	SR29	SR59	N/A	N/A	SR65	SR75	N/A														
Width (W)		3.81 (.150)	5.08 (.200)	5.08 (.200)	5.08 (.200)	6.604 (.260)	7.62 (.300)	10.16 (.400)	12.70 (.500)														
Height (H)		3.81 (.150)	5.08 (.200)	5.08 (.200)	5.08 (.200)	6.35 (.250)	7.62 (.300)	10.16 (.400)	12.70 (.500)														
Thickness (T)		2.54 (.100)	3.175 (.125)	3.175 (.125)	3.175 (.125)	4.06 (.160)	3.81 (.150)	3.81 (.150)	5.08 (.200)														
Lead Spacing (L.S.)		2.54 (.100)	2.54 (.100)	5.08 (.200)	6.35 (.250)	7.62 (.300)	5.08 (.200)	5.08 (.200)	10.16 (.400)														
Lead Diameter (L.D.)		.508 (.020)	.508 (.020)	.508 (.020)	.508 (.020)	.508 (.020)	.508 (.020)	.508 (.020)	.635 (.025)														
Cap. in.* Industry Preferred pF	Values in Blue	WVDC			WVDC			WVDC			WVDC			WVDC			WVDC						
		200	100	50	200	100	50	200	100	50	200	100	50	200	100	50	200	100	50	200	100	50	
1.0-9.9	SR151A1R0DAA																						
10	SR151A100KAA																						
15	SR.....A150KAA																						
22	SR.....A220KAA																						
33	SR.....A330KAA																						
39	SR.....A390KAA																						
47	SR.....A470KAA																						
68	SR.....A680KAA																						
100	SR151A101KAA																						
150	SR.....A151KAA																						
220	SR.....A221KAA																						
330	SR.....A331KAA																						
390	SR.....A391KAA																						
470	SR.....A471KAA																						
680	SR.....A681KAA																						
1000	SR211A102KAA																						
1500	SR.....A152KAA																						
2200	SR.....A222KAA																						
3900	SR.....A392KAA																						
4700	SR.....A472KAA																						
6800	SR.....A682KAA																						
8200	SR.....A822KAA																						
10,000	SR305A103KAA																						
15,000	SR.....A153KAA																						
22,000	SR.....A223KAA																						
33,000	SR.....A333KAA																						
39,000	SR.....A393KAA																						
47,000	SR.....A473KAA																						
68,000	SR.....A683KAA																						
100,000	SR.....A104KAA																						

For other styles, voltages, tolerances and lead lengths see Part No. Codes or contact factory.

*Other capacitance values available upon special request.

= Industry preferred values
 = SR20 only

NOTE: Capacitance Ranges available for SR12 same as SR15
 SR62 same as SR21
 SR64 same as SR30
 SR89 same as SR21

SIZE AND CAPACITANCE SPECIFICATIONS

EIA Characteristic

Dimensions: Millimeters (Inches)

AVX Style	SR15	SR20	SR21	SR22	SR27	SR30	SR40	SR50										
AVX "Insertable"	SR07	SR29	SR59	N/A	N/A	SR65	SR75	N/A										
Width (W)	3.81 (.150)	5.08 (.200)	5.08 (.200)	5.08 (.200)	6.604 (.260)	7.62 (.300)	10.16 (.400)	12.70 (.500)										
Height (H)	3.81 (.150)	5.08 (.200)	5.08 (.200)	5.08 (.200)	6.35 (.250)	7.62 (.300)	10.16 (.400)	12.70 (.500)										
Thickness (T)	2.54 (.100)	3.175 (.125)	3.175 (.125)	3.175 (.125)	4.06 (.160)	3.81 (.150)	3.81 (.150)	5.08 (.200)										
Lead Spacing (L.S.)	2.54 (.100)	2.54 (.100)	5.08 (.200)	6.35 (.250)	7.62 (.300)	5.08 (.200)	5.08 (.200)	10.16 (.400)										
Lead Diameter (L.D.)	.508 (.020)	.508 (.020)	.508 (.020)	.508 (.020)	.508 (.020)	.508 (.020)	.508 (.020)	.635 (.025)										
Cap. in.* pF	Industry Preferred Values in Blue	WVDC		WVDC		WVDC		WVDC		WVDC		WVDC		WVDC		WVDC		
		200	100	50	200	100	50	200	100	50	100	50	200	100	50	200	100	50
470	SR.....C471KAA																	
1000	SR155C102KAA																	
1500	SR.....C152KAA																	
2200	SR.....C222KAA																	
3300	SR.....C332KAA																	
4700	SR.....C472KAA																	
6800	SR.....C682KAA																	
10,000	SR215C103KAA																	
15,000	SR.....C153KAA																	
22,000	SR.....C223KAA																	
33,000	SR.....C333KAA																	
47,000	SR.....C473KAA																	
68,000	SR.....C683KAA																	
100,000	SR215C104KAA																	
150,000	SR.....C154KAA																	
220,000	SR215C224KAA																	
330,000	SR.....C334KAA																	
390,000	SR.....C394KAA																	
470,000	SR305C474KAA																	
1.0 µF	SR305C105KAA																	
2.2 µF	SR405C225KAA																	
2.7 µF	SR505C275KAA																	
4.7 µF	SR505C475KAA																	

For other styles, voltages, tolerances and lead lengths see Part No. Codes or contact factory.

*Other capacitance values available upon special request.

- = Industry preferred values
- = SR20 only
- = Extended range
- = Extended range, SR20 only
- = Extended range with 0.150" thickness maximum

NOTE: Capacitance Ranges available for SR12 same as SR15
 SR62 same as SR21
 SR64 same as SR30
 SR89 same as SR21

Z5U Dielectric

SIZE AND CAPACITANCE SPECIFICATIONS

EIA Characteristic

Dimensions: Millimeters (Inches)

AVX Style	SR15	SR20	SR21	SR22	SR27	SR30	SR40	SR50
AVX "Insertable"	SR07	SR29	SR59	N/A	N/A	SR65	SR75	N/A
Width (W)	3.81 (.150)	5.08 (.200)	5.08 (.200)	5.08 (.200)	6.604 (.260)	7.62 (.300)	10.16 (.400)	12.70 (.500)
Height (H)	3.81 (.150)	5.08 (.200)	5.08 (.200)	5.08 (.200)	6.35 (.250)	7.62 (.300)	10.16 (.400)	12.70 (.500)
Thickness (T)	2.54 (.100)	3.175 (.125)	3.175 (.125)	3.175 (.125)	4.06 (.160)	3.81 (.150)	3.81 (.150)	5.08 (.200)
Lead Spacing (L.S.)	2.54 (.100)	2.54 (.100)	5.08 (.200)	6.35 (.250)	7.62 (.300)	5.08 (.200)	5.08 (.200)	10.16 (.400)
Lead Diameter (L.D.)	.508 (.020)	.508 (.020)	.508 (.020)	.508 (.020)	.508 (.020)	.508 (.020)	.508 (.020)	.635 (.025)
Cap. in.* Industry Preferred Values in Blue	WVDC 100 50	WVDC 100 50	WVDC 100 50	WVDC 100 50	WVDC 100 50	WVDC 100 50	WVDC 100 50	WVDC 100 50
10,000 47,000 100,000	SR15E103ZAA SR.....E473ZAA SR215E104ZAA							
150,000 220,000 330,000	SR.....E154ZAA SR215E224ZAA SR215E334ZAA							
470,000 680,000	SR215E474ZAA SR.....E684ZAA							
1.0 µF 1.5 µF 2.2 µF	SR.....105ZAA SR30E155ZAA SR30E225ZAA							
3.3 µF 4.7 µF	SR30E335ZAA SR30E475ZAA							

For other styles, voltages, tolerances and lead lengths see Part No. Codes or contact factory.

*Other capacitance values available upon special request.

- = Industry preferred values
- = SR20 only

AVX 500 VOLT SKYCAPS**

STYLE*	MAXIMUM CAPACITANCE VALUE	
	COG (NP0)	X7R
SR29	900 pF	.015 µF
SR20	1800 pF	.033 µF
SR28 SR59	900 pF	.015 µF
SR13 SR21	1800 pF	.033 µF
SR30 SR61 SR65	7200 pF	.12 µF
SR40 SR75	.015 µF	.27 µF
SR22	1800 pF	.033 µF
SR27	1800 pF	.033 µF
SR76	.015 µF	.27 µF
SR50	.036 µF	.59 µF

*Consult pages 22 and 23 for style sizes.

**Voltage rating based on DWV of 150% of rated voltage.

Configurations by Lead Spacing

LEAD SPACING .100 ±.030				Dimensions: Inches (Millimeters)			
<p>AR07/SR07* (T=.100)</p>	<p>AR14/SR14 (T=.100)</p>	<p>AR15/SR15* (T=.100)</p>	<p>AR20/SR20* (T=.125)</p>	<p>AR29/SR29* (T=.125)</p>	<p>AR62/SR62* (T=.125)</p>	<p>SR62-LP* (T=.100)</p>	

LEAD SPACING .200 ±.030					Dimensions: Inches (Millimeters)									
<p>AR12/SR12* (T=.100)</p>	<p>SR13* (T=.125)</p>	<p>AR21/SR21* (T=.125)</p>	<p>SR21-85* (T=.125)</p>	<p>SR28* (T=.125)</p>	<p>AR30/SR30* (T=.150)</p>	<p>SR30-LP* (T=.150)</p>	<p>AR32/SR32* (T=.150)</p>	<p>AR40/SR40* (T=.150)</p>	<p>AR59/SR59* (T=.125)</p>	<p>SR61 (T=.150)</p>	<p>SR63* (T=.150)</p>	<p>SR64* (T=.150)</p>	<p>SR64-LP* (T=.150)</p>	<p>AR65/SR65* (T=.150)</p>
<p>AR30/SR30* (T=.150)</p>	<p>SR30-LP* (T=.150)</p>	<p>AR32/SR32* (T=.150)</p>	<p>AR40/SR40* (T=.150)</p>	<p>AR59/SR59* (T=.125)</p>	<p>SR61 (T=.150)</p>	<p>SR63* (T=.150)</p>	<p>SR64* (T=.150)</p>	<p>SR64-LP* (T=.150)</p>	<p>AR65/SR65* (T=.150)</p>					
<p>SR61 (T=.150)</p>	<p>SR63* (T=.150)</p>	<p>SR64* (T=.150)</p>	<p>SR64-LP* (T=.150)</p>	<p>AR65/SR65* (T=.150)</p>										

SkyCap®/AR Series

Configuration by Lead Spacing

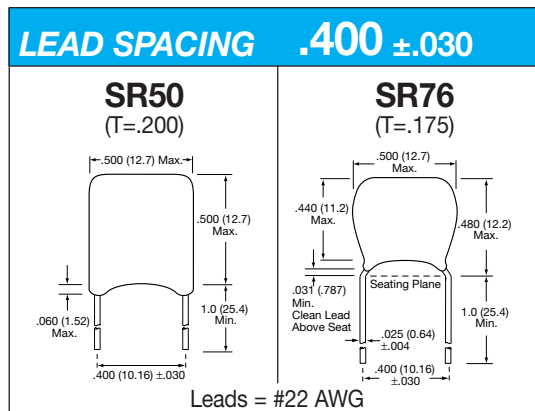
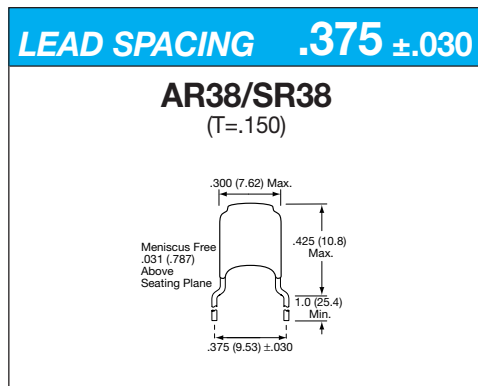
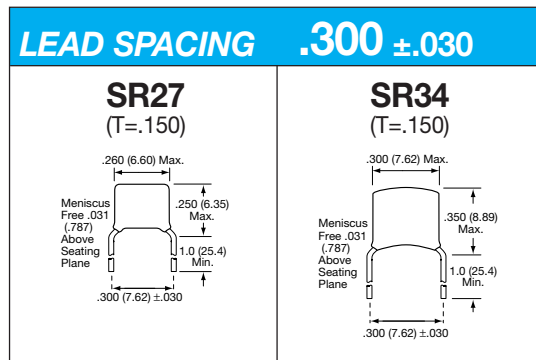
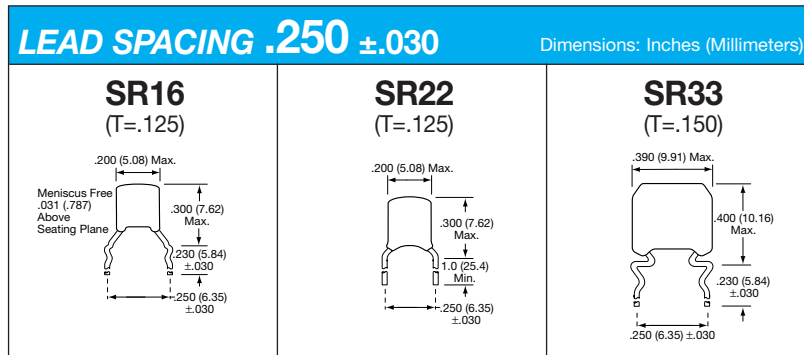
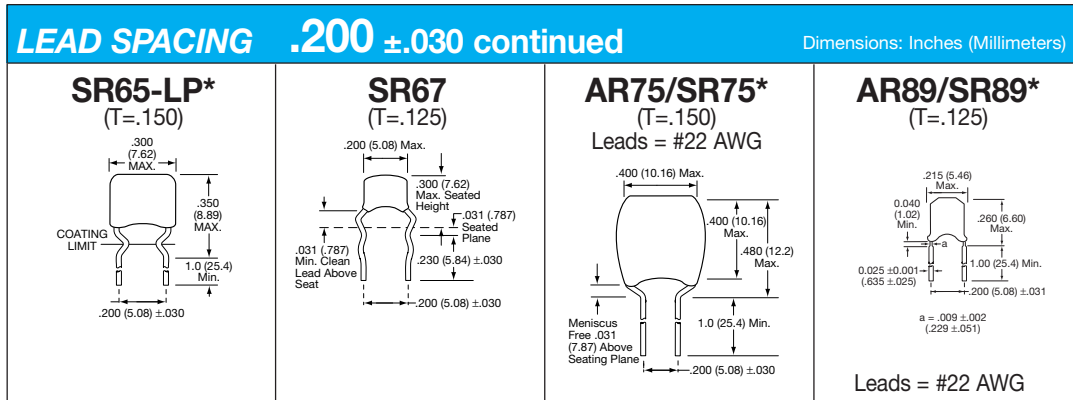

- NOTES:**
1. All leads are #24 AWG unless otherwise noted.
 2. Available in tape and reel packaging(*).
 3. Other styles are also available, contact factory.
 4. (T = XXX) under type designation is maximum thickness in inches.



Radial Leads/Packaging

Tape and Reel



GENERAL INFORMATION

1. Standard reel diameter is 355 millimeters (14 inches) maximum.
2. Reeling standard (#1 or #2) should be specified when ordering.

HOW TO ORDER

To specify tape and reel packaging, add TR1, TR2 or TRX to the end of the AVX 12 digit part number.

Examples:

SR215C104KAATR1
 SR305E105MAATR2
 SR215C103JAATR3

THE INSERTABLES

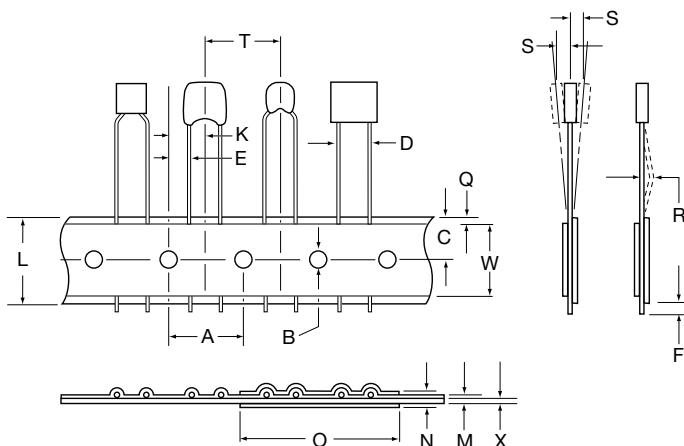
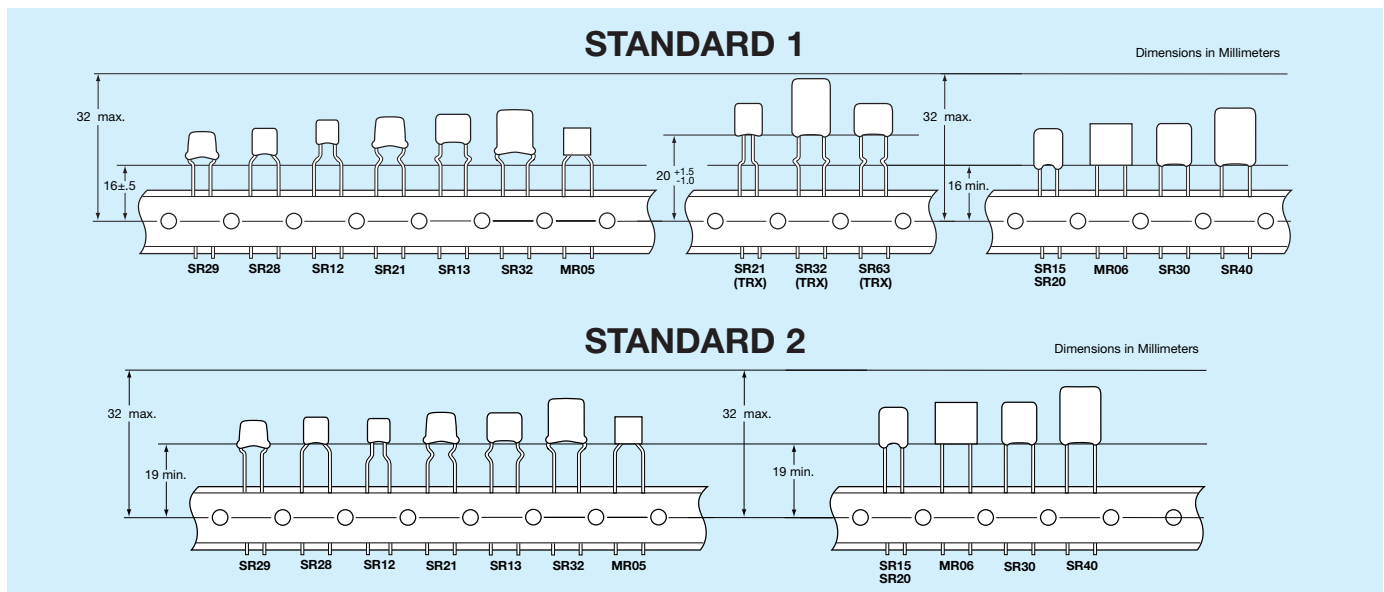
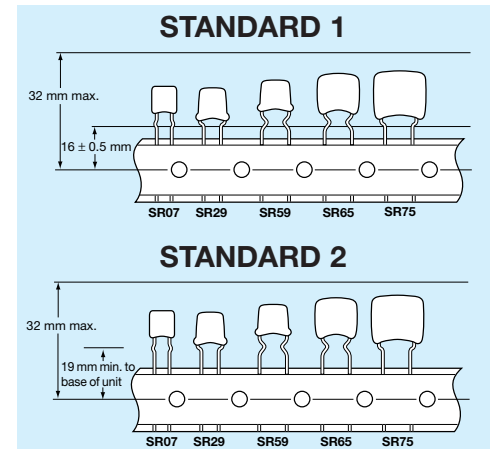

DESCRIPTION

DIMENSIONS (MM)

A. Feed Hole Pitch	12.70 ± .20
B. Feed Hole Diameter	3.99 ± .20
C. Feed Hole Location	9.02 ± .51
D. Component Lead Spacing	5.00 ^{+0.79} _{-.20} or 2.54 ^{+0.79} _{-.20}
E. Component Lead Location	3.81 ± .51 or 5.00 ± .51 for 2.54 lead spacing 2.00 maximum
F. Component Lead Protrusion (edge of carrier to cut end of lead)	2.00 maximum
K. Component Body Location	6.35 ± .41
L. Carrier Tape Width	18.01 ^{+1.02} _{-.51}
M. Carrier Tape Assembly Thickness	.71 ± .20
N. Carrier Tape Spliced Thickness	1.42 maximum
O. Carrier Tape Spliced Length	50.80 - 88.90
Q. Adhesive Tape Border	3.00 maximum
R. Component Bent Leads (either direction)	.79 maximum
S. Component Misalignment	.99 maximum
T. Component Pitch	12.70 ± .99
W. Adhesive Tape Width	5.00 minimum
X. Carrier Tape Thickness	.51 ± .10
Y. Cumulative Pitch over 20 Pitches	254 ± 2.00



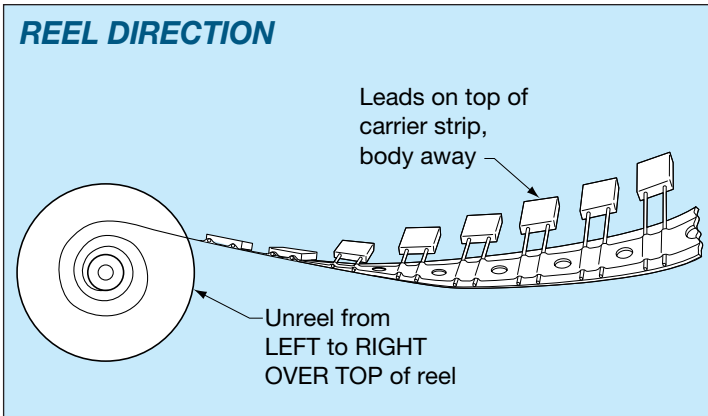

QUANTITY PER REEL SR/AR	
PART	PCS
SR15, 07, 12	3500
SR20, 21, 23, 28 13, 29, 59, 62, 89	3000
SR30, 32, 40, 63, 64 65, 75	2000
MR05, 06	2500

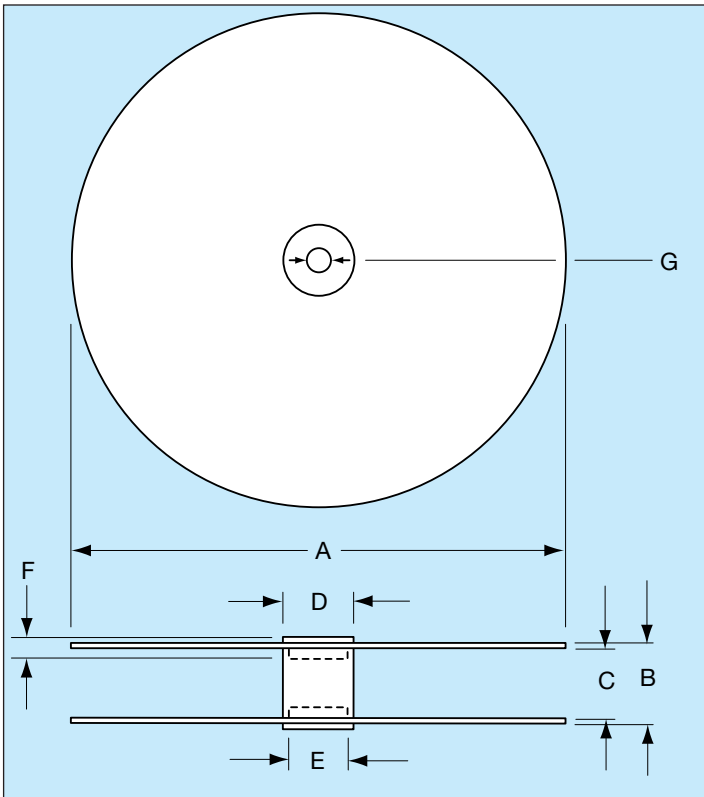

DESCRIPTION	DIMENSIONS (MM)
A - Reel Diameter	304.80 - 355
B - Reel Outside Width	50.80 maximum
C - Reel Inside Width	38.10 - 46.02
D - Core Diameter (O.D.)	102.01 maximum
E - Hub Recess Diameter	86.36 maximum
F - Hub Recess Depth	9.50 minimum
G - Arbor Hole Diameter	25.40 - 30.48

CONVERSION TABLE									
MM	IN	MM	IN	MM	IN	MM	IN	MM	IN
.10	.004	1.52	.060	5.00	.197	9.91	.390	32.00	1.260
.20	.007	2.00	.079	5.08	.200	10.03	.395	38.10	1.500
.38	.015	2.54	.100	6.22	.245	10.16	.400	46.02	1.812
.41	.016	3.00	.118	6.35	.250	11.68	.460	50.80	2.000
.51	.020	3.18	.125	6.60	.260	12.50	.492	86.36	3.400
.71	.028	3.48	.137	6.99	.275	12.70	.500	88.90	3.500
.79	.031	3.81	.150	7.62	.300	16.00	.630	102.01	4.016
.99	.039	3.99	.157	8.89	.350	18.01	.709	254.00	10.000
1.02	.040	4.45	.175	9.02	.355	25.40	1.000	304.80	12.000
1.42	.056	4.98	.196	9.50	.374	30.48	1.200	355.00	14.000