

Features

- ARM7TDMI® ARM® Thumb® Processor Core
 - High Performance 32-bit RISC
 - High-density 16-bit Instruction set (Thumb)
 - Leader in MIPS/Watt
 - Embedded ICE (In Circuit Emulation)
- 16 Kbytes Internal SRAM
- Fully Programmable External Bus Interface (EBI)
 - Maximum External Address Space of 6 Mbytes, Up to Four Chip Select Lines
- 8-level Priority, Vectored Interrupt Controller
 - Three External Interrupts Including One Fast Interrupt Line
- Ten Channel Peripheral Data Controller (PDC)
- 57 Programmable I/O Lines
- Four 16-bit General Purpose Timers (GPT)
 - Three Configurable Modes: Counter, PWM, Capture
 - Four External Clock Inputs, Three Multi-purpose I/O Pins per Timer
- Four 16-bit Simple Timers (ST)
- Four Channel 16-bit Pulse Width Modulation (PWM)
- Four CAN Controllers 2.0A and 2.0B Full CAN
 - One with 32 Buffers, Three with 16 Buffers
- Two USARTs
 - Support for J1587 and LIN Protocols
- One Master/Slave SPI Interface
 - 8 to 16-bit Programmable Data Length
 - Four External Serial Peripheral Chip Selects
- Two 8-channel 10-bit Analog to Digital Converters (ADC)
- Two 16-bit Capture Modules (CAPT)
- Programmable Watch Timer (WT)
- Programmable Watchdog (WD)
- Power Management Controller (PMC)
 - 32 kHz Oscillator, Main Oscillator and PLL
- IEEE 1149.1 JTAG Boundary-scan on all Digital Pins
- Fully Static Operation: 0 Hz to 30 MHz at VDDCORE=3.3V, 85°C
- 3.0V to 5.5V Operating Voltage Range
- 3.0V to 3.6V Core, Memory and Analog Voltage Range
- -40° to +85°C Operating Temperature Range
- Available in a 176-lead LQFP Package

Description

The AT91SAM7A2 is based on the ARM7TDMI embedded processor. This processor has a high-performance 32-bit RISC architecture with a high-density 16-bit instruction set and very low power consumption.

In addition, a large number of internally banked registers result in very fast exception handling, making the device ideal for real-time control applications.

The AT91SAM7A2 has a direct connection to off-chip memory, including Flash, through the fully programmable External Bus Interface.

An 8-level priority vectored Interrupt Controller in conjunction with the Peripheral Data Controller significantly improves the real time performance of the device. The device is manufactured using high-density CMOS technology.

By combining the ARM7TDMI processor with an on-chip SRAM, and a wide range of peripheral functions, including USART, SPI, CAN Controllers, Timer Counter and Analog-to-Digital Converters, on a monolithic chip, the AT91SAM7A2 is a powerful device that provides a flexible, cost-effective solution to many compute-intensive embedded control applications in the automotive and industrial world.



AT91 ARM® Thumb®- based Microcontrollers

AT91SAM7A2

Summary

6021BS-ATARM-06-Jul-04



PRELIMINARY

Block Diagram

Figure 1. Block Diagram

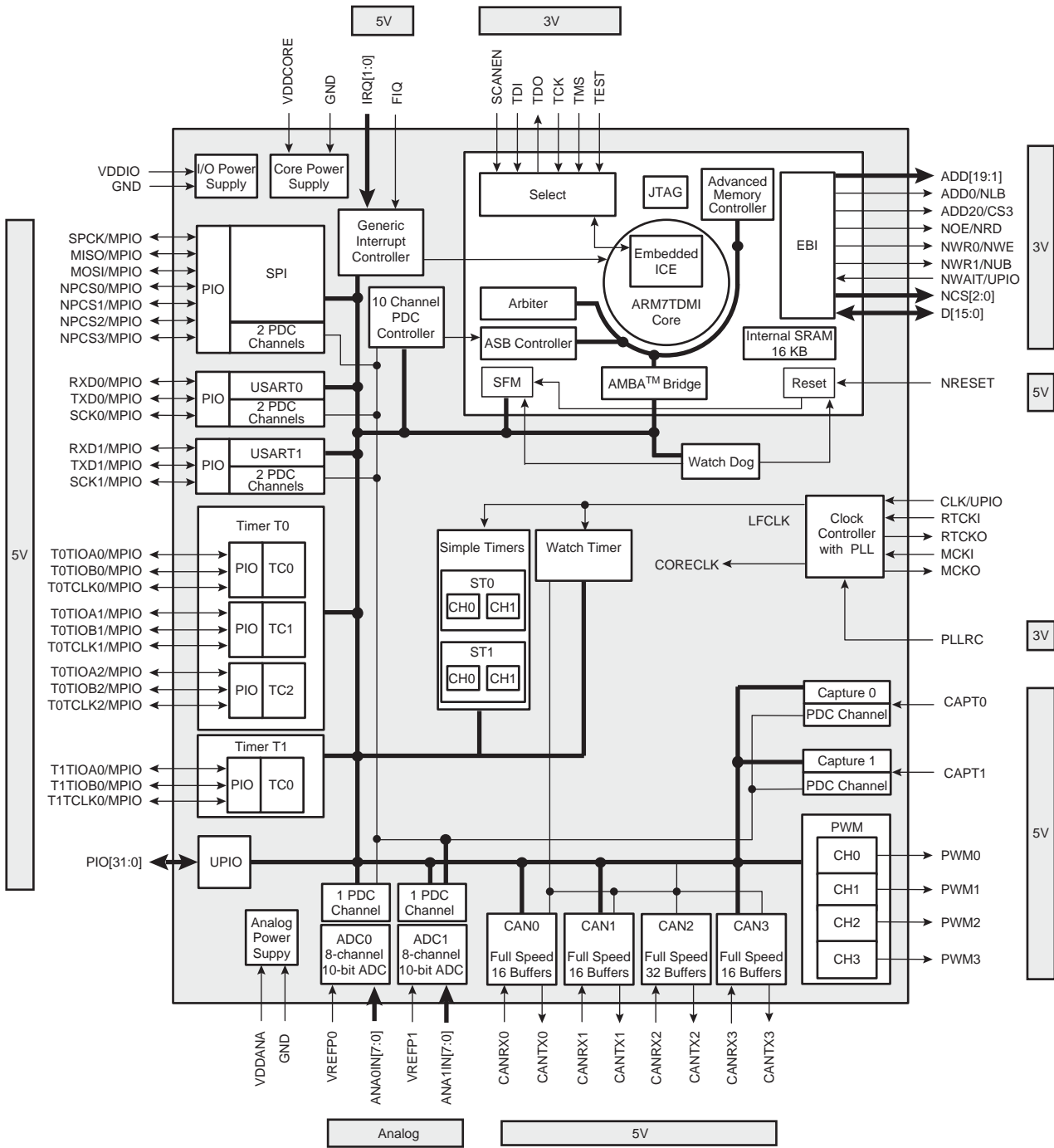

Pin Configuration

Table 1. Pinout

Pin	Name	Pin	Name	Pin	Name	Pin	Name
1	VDDIO	45	GND	89	VDDIO	133	NOE/NRD
2	IRQ0	46	VDDIO	90	VDDANA	134	NCS0
3	IRQ1	47	UPIO5	91	VREFP0	135	ADD1
4	FIQ	48	UPIO6	92	ANA0IN0	136	D9
5	SCK0/MPIO	49	GND	93	ANA0IN1	137	D2
6	TXD0/MPIO	50	VDDIO	94	ANA0IN2	138	VDDCORE
7	RXD0/MPIO	51	UPIO7	95	ANA0IN3	139	D10
8	SCK1/MPIO	52	UPIO 8	96	ANA0IN4	140	D3
9	TXD1/MPIO	53	UPIO 9	97	ANA0IN5	141	D11
10	RXD1/MPIO	54	UPIO 10	98	ANA0IN6	142	D4
11	VDDCORE	55	UPIO 11	99	GND	143	D12
12	CANTX3	56	UPIO 12	100	VDDANA	144	D5
13	CANRX3	57	UPIO 13	101	ANA0IN7	145	D13
14	CAPT0	58	UPIO 14	102	VREFP1	146	D6
15	CAPT1	59	UPIO 15	103	ANA1IN0	147	D14
16	SPCK/MPIO	60	UPIO 16	104	ANA1IN1	148	D7
17	MISO/MPIO	61	UPIO 17	105	ANA1IN2	149	D15
18	MOSI/MPIO	62	UPIO 18	106	ANA1IN3	150	GND
19	NPCS0/MPIO	63	GND	107	ANA1IN4	151	ADD0/NLB
20	VDDIO	64	VDDIO	108	ANA1IN5	152	ADD17
21	GND	65	UPIO19	109	ANA1IN6	153	ADD16
22	NPCS1/MPIO	66	UPIO20	110	ANA1IN7	154	ADD15
23	NPCS2/MPIO	67	UPIO21	111	GND	55	ADD14
24	NPCS3/MPIO	68	UPIO22	112	VDDCORE	156	ADD13
25	T0TIOA0/MPIO	69	UPIO23	113	RTCKI	157	ADD12
26	T0TIOB0/MPIO	70	UPIO24	114	RTCKO	158	ADD11
27	T0TCLK0/MPIO	71	UPIO25	115	GND	159	ADD10
28	T0TIOA1/MPIO	72	UPIO26	116	VDDCORE	160	ADD9
29	T0TIOB1/MPIO	73	UPIO27	117	SCANEN	161	ADD20/CS3
30	T0TCLK1/MPIO	74	UPIO28	118	TEST	162	VDDCORE
31	T0TIOA2/MPIO	75	UPIO29	119	TMS	163	NWR0/NWE
32	T0TIOB2/MPIO	76	UPIO30/NWAIT	120	TDO	164	NCS2
33	VDDIO	77	UPIO31/CORECLK	121	TDI	165	NCS1
34	GND	78	CANTX0	122	TCK	166	ADD19
35	T0TCLK2/MPIO	79	CANRX0	123	GND	167	ADD18
36	T1TIOA0/MPIO	80	CANTX1	124	PLLRC	168	ADD8
37	T1TIOB0/MPIO	81	CANRX1	125	VDDCORE	169	ADD7
38	T1TCLK0/MPIO	82	CANTX2	126	MCKI	170	ADD6
39	NRESET	83	CANRX2	127	MCKO	171	ADD2
40	UPIO0	84	PWM0	128	GND	172	ADD3
41	UPIO1	85	PWM1	129	NWR1/NUB	173	ADD4
42	UPIO2	86	PWM2	130	D8	174	ADD5
43	UPIO3	87	PWM3	131	D1	175	GND
44	UPIO4	88	GND	132	D0	176	GND

Figure 2. Pin Configuration

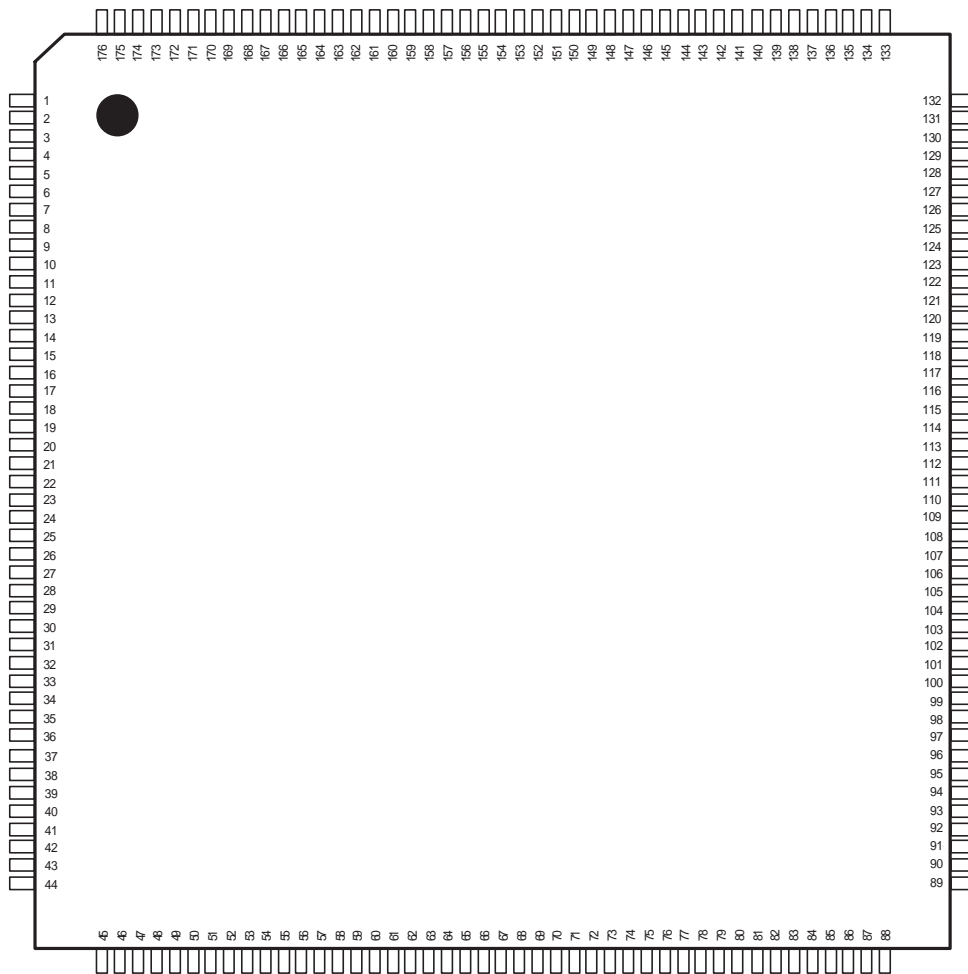

Signal Description

Table 2. Signal Description

Module	Name	Function	Type	Active Level	Comments	
EBI	ADD[19:1]	External address bus	O	(Z) ⁽¹⁾	The EBI is tri-stated when NRESET is at a logical low level. Internal pull-downs on data bus bits	
	ADD0/NLB	External address line line/ Lower byte enable	O	L (Z)		
	ADD20/CS3	External address line/ Chip select	O	H (Z)		
	D[15:0]	External data bus	I/O	(Z)		
	NOE	Output enable	O	L (Z)		
	NWR0/NWE	Write enable	O	L (Z)		
	NCS[2:0]	Chip select lines	O	L (Z)		
	NWR1/NUB	Upper byte enable	O	L (Z)		
	NWAIT	External Wait	I	L		Disable at reset, multiplexed with UPIO30
	CORECLK	Core CLock	O			Disable at reset, multiplexed with UPIO31
GIC	IRQ[1:0]	External interrupt lines	I			
	FIQ	Fast interrupt line	I			
Power-on Reset	NRESET	Hardware reset input	I	L	Schmitt input with internal filter	
Master Clock	MCKI	Master clock input	I		Connected to external crystal (4 to 6 Mhz)	
	MCKO	Master clock output	O			
	PLLRC	PLL RC network input	I			
32.768 kHz clock	RTCKI	32.768 KHz clock input	I		Connected to external 32.768 Khz crystal	
	RTCKO	32.768 KHz clock output	O			
PIO	UPIO[31:0]	General purpose I/O	I/O	(Z)		
USART0	SCK0/MPIO	USART0 clock line	I/O	(Z)	Multiplexed with general purpose I/O	
	RXD0/MPIO	USART0 receive line	I/O	(Z)	Multiplexed with general purpose I/O	
	TXD0/MPIO	USART0 transmit line	I/O	(Z)	Multiplexed with general purpose I/O	
USART1	SCK1/MPIO	USART1 clock line	I/O	(Z)	Multiplexed with general purpose I/O	
	RXD1/MPIO	USART1 receive line	I/O	(Z)	Multiplexed with general purpose I/O	
	TXD1/MPIO	USART1 transmit line	I/O	(Z)	Multiplexed with general purpose I/O	
Capture0	CAPT0	Capture input	I			
Capture1	CAPT1	Capture input	I			
PWM	PWM[3:0]	Pulse Width Modulation output	O	(L)		
Timer T0	T0TIOA[2:0]/MPIO	Capture/waveform I/O	I/O	(Z)	Multiplexed with a general purpose I/O	
	T0TIOB[2:0]/MPIO	Trigger/waveform I/O	I/O	(Z)	Multiplexed with a general purpose I/O	
	T0TIOCLK[2:0]/MPIO	External clock/trigger/input IO	I/O	(Z)	Multiplexed with a general purpose I/O	

Table 2. Signal Description (Continued)

Module	Name	Function	Type	Active Level	Comments
Timer T1	T1TIOA/MPIO	Capture/waveform I/O	I/O	(Z)	Multiplexed with a general purpose I/O
	T1TIOB/MPIO	Trigger/waveform I/O	I/O	(Z)	Multiplexed with a general purpose I/O
	T0TIOCLK/MPIO	External clock/trigger/input	I/O	(Z)	Multiplexed with a general purpose I/O
ADC0	ANA0IN[7:0]	Analog input	I		
	VREFP0	Positive voltage reference	I		
ADC1	ANA1IN[7:0]	Analog input	I		
	VREFP1	Positive voltage reference	I		
SPI	SPCK/MPIO	SPI clock line	I/O	(Z)	Multiplexed with a general purpose I/O
	MISO/MPIO	SPI master in slave out	I/O	(Z)	Multiplexed with a general purpose I/O
	MOSI/MPIO	SPI master out slave in	I/O	(Z)	Multiplexed with a general purpose I/O
	NPCS[3:1]/MPIO	SPI chip select	I/O	(Z)	Multiplexed with a general purpose I/O
	NPCS0/NSS/MPIO	SPI chip select (slave input)	I/O	(Z)	Multiplexed with a general purpose I/O
CAN0	CANRX0	CAN0 receive line	I	L	
	CANTX0	CAN0 transmit line	O	L (H)	
CAN1	CANRX1	CAN1 receive line	I	L	
	CANTX1	CAN1 transmit line	O	L (H)	
CAN2	CANRX2	CAN2 receive line	I	L	
	CANTX2	CAN2 transmit line	O	L (H)	
CAN3	CANRX3	CAN3 receive line	I	L	
	CANTX3	CAN3 transmit line	O	L (H)	
JTAG	SCANEN	Scan enable	I	H	Internal pull-down (connected GND or leave unconnected)
	TDI	Test Data In	I		Schmitt trigger, internal pull-up
	TDO	Test Data Out	O		
	TMS	Test Mode Select	I		Schmitt trigger, internal pull-up
	TCK	Test Clock	I		Schmitt trigger, internal pull-up
	TEST	Factory Test	I	H	Internal pull-down (connected GND or leave unconnected)
Power Supplies	VDDCORE	Core Power Supply	-		3.3V
	VDDANA	Analog Power Supply	-		3.3V
	VDDIO	I/O Lines Power Supply	-		3.3V to 5V
	GND	Ground	-		

Note: 1. Values in brackets are the values at reset (H = High, L = Low, Z = High impedance state).

Architectural Overview

The AT91SAM7A2 architecture consists of two main buses, the Advanced System Bus (ASB) and the Advanced Peripheral Bus (APB). The ASB is designed for maximum performance. It interfaces the processor with the on-chip 32-bit memories and the external memories and devices by means of the External Bus Interface (EBI). The APB is designed for access to on-chip peripherals and is optimized for low power consumption. The AMBA™ Bridge provides an interface between the ASB and the APB.

The AT91SAM7A2 peripherals are designed to be programmed with a minimum number of instructions. Each peripheral has a 16 Kbyte address space allocated in the upper 1 Mbytes of the 4 Gbyte address space. Except for the interrupt controller, the peripheral base address is the lowest address of its memory space. The peripheral register set is composed of control, mode, data, status and interrupt registers. To maximize the efficiency of bit manipulation, frequently written registers are mapped into three memory locations. The first address is used to set the individual register bits, the second resets the bits and the third address reads the value stored in the register. A bit can be set or reset by writing a one to the corresponding position at the appropriate address. Writing a zero has no effect. Individual bits can thus be modified without having to use costly read-modify-write and complex bit manipulation instructions.

The ARM7TDMI processor operates in little-endian mode in the AT91SAM7A2 microcontroller. The processor's internal architecture and the ARM and Thumb instruction sets are described in the ARM7TDMI Datasheet.

AMC: Advanced Memory Controller

The AT91SAM7A2 embeds 16 Kbytes of internal SRAM. The internal memory is directly connected to the 32-bit data bus and is single-cycle accessible. This provides maximum performance of 27 MIPS @ 30 MHz by using the ARM® instruction set of the processor, minimizing system power consumption and improving on the performance of separate memory solutions.

EBI: External Bus Interface

The EBI generates the signals which control the accesses to the external memories or peripheral devices. The EBI is fully programmable and can address up to 6 Mbytes. It has four chip selects and a 21-bit address bus, the upper bit of which is multiplexed with a chip select. Separate read and write control signals allow for direct memory and peripheral interfacing. The EBI supports different access protocols allowing single clock cycle memory accesses. The main features are:

- External Memory Mapping
- Up to Four Chip Select Lines
- Byte Write or Byte Select Lines
- 8-bit or 16-bit Data Bus
- External Wait
- Remap of Boot Memory
- Two Different Read Protocols
- Programmable Wait State Generation

GIC: Generic Interrupt Controller

The AT91SAM7A2 has an 8-level priority, individually maskable, vectored interrupt controller. This feature substantially reduces the software and real time overhead in handling internal and external interrupts. The interrupt controller is connected to the nFIQ (fast interrupt request) and the nIRQ (standard interrupt request) inputs of the ARM7TDMI™ processor. The processor's nFIQ line can only be asserted by the external fast interrupt request input: FIQ. The nIRQ line can be asserted by the interrupts generated by the on-chip peripherals and the external interrupt request lines: IRQ0 to IRQ1. An 8-level priority encoder allows the customer to define the priority between the different nIRQ interrupt sources. Internal sources are programmed to

be level sensitive or edge triggered. External sources can be programmed to be positive or negative edge triggered or high or low level sensitive.

PIO: Parallel I/O Controller

The AT91SAM7A2 has 57 configurable I/O lines. 32 pins (United PIO) on the AT91SAM7A2 are dedicated as general purpose I/O pins (UPIO0 to UPIO31). Other I/O lines are multiplexed with an external signal of a peripheral to optimize the use of available package pins. The United-PIO is controlled by a dedicated module. The others pins are configure in each module.

PDC: Peripheral Data Controller

An on-chip, 10-channel Peripheral Data Controller (PDC) transfers data between the on-chip peripherals and the on and off-chip memories without processor intervention. One PDC channel is connected to the receiving channel and one to the transmitting channel of each USART and of the SPI. A single PDC channel is connected to each ADC and each Capture.

Most importantly, the PDC removes the processor interrupt handling over-head and significantly reduces the number of clock cycles required for a data transfer. It can transfer up to 64 Kbytes without reprogramming the starting address. As a result, the performance of the micro-controller is increased and the power consumption reduced.

USART: Universal Synchronous Asynchronous Receiver Transmitter

The AT91SAM7A2 provides two identical, full-duplex, universal synchronous asynchronous receiver transmitter which are connected to the Peripheral Data Controller. The main features are:

- Programmable Baud Rate Generator
- Parity, Framing and Overrun Error Detection
- Line Break Generation and Detection
- Automatic Echo, Local & Remote Loopback Modes
- Multi-drop Mode: Address Detection and Generation
- Interrupt Generation
- Two Dedicated Peripheral Data Controller Channels
- 5-, 6-, 7-, 8- and 9-bit Character Length
- Idle Flag for J1587 Protocol.
- Smart Card Transmission Error Feature
- Support LIN 1.2 Protocol with H/W Layer

SPI: Serial Peripheral Interface

The AT91SAM7A2 features an SPI that provides communication with external devices in master or slave mode. The SPI has four external chip selects that can be connected to up to 15 devices. The data length is programmable from 8- to 16-bit.

As for the USART, a two-channel PDC is used to move data directly between memory and the SPI without CPU intervention for maximum real-time processing throughput.

CAN: Controller Area Network

The AT91SAM7A2 provides four CANs (2.0A and 2.0B). These are based upon serial communications protocol which efficiently supports distributed real-time control with a very high level of security (one with 32 mailboxes and the others with 16 mailboxes).

The main features are:

- Prioritization of Messages
- Multi-master
- System Wide Data Consistency
- Error Detection and Error Signaling
- Automatic Retransmission Of Corrupted Messages

- Automatic Reply After Receive a Remote Frame
- Time Stamp on Each Transfer
- Multicast Reception with Time Synchronization
- Continuous Reception Mode

GPT: General Purpose Timer

The AT91SAM7A2 features four General Purpose Timers. Each timer can be independently programmed to perform a wide range of functions including frequency measurement, event counting, interval measurement, pulse generation, delay timing and pulse width modulation.

Each General Purpose Timer has one external clock input, five internal clock inputs, and three multi-purpose input/output signals which can be configured by the user. Each timer drives an internal interrupt signal which can be programmed to generate processor interrupts via the AIC (Advanced Interrupt Controller).

Three General Purpose Timers are grouped in the same block. This block has two global registers which act upon all three GPTs. The Block Control Register allows the three timers to be started simultaneously with the same instruction. The Block Mode Register defines the external clock inputs for each timer, allowing them to be chained.

ST: Simple Timer

Simple Timers provide basic functions for timing calculation. Each channel of this timer has a specific prescaler and a 16-bit counter. The prescaler defines the clock frequency of the channel counter. The 16-bit counter starts down-counting when a value different than zero is loaded. An interrupt is generated when the counter is null.

CAPT: Capture Module

The capture module is a frame analyzer. It stores the period of time between two edges of a signal in a register. This period is described as a number of counter cycles. The capture allows data transfers with the PDC.

PWM: Pulse Width Modulation

The AT91SAM7A2 includes four PWM channels. Each channel can generate pulses. The frequency and the duty cycle of each channel can be configured.

WT: Watch Timer

The watch timer provides a seconds counter and an alarm function. The alarm register has a resolution of 30.5 μ s. This allows a 32-bit register to have sufficient range to cater for a 24 or 36 hour period.

WD: Watch Dog

The AT91SAM7A2 has an internal watchdog which can be used to prevent system lock-up if the software becomes trapped in a deadlock.

SFM: Special Function Module

The AT91SAM7A2 provides registers which implement the following special functions.

- Chip Identification
- RESET Status

ADC: Analog to Digital Converter

The two identical 8-channel 10-bit Analog-to-Digital Converters (ADC) are based on a Successive Approximation Register (SAR) approach. Each ADC has 8 analog input pins, ANA0IN0 to ANA0IN7 and ANA1IN0 to ANA1IN7, and provides an interrupt signal to the AIC. Both ADCs share the analog power supply pins V_{DDA} and GND_A, and the input reference voltage pin V_{REFP} . Each channel can be enabled or disabled independently, and has its own data register. The ADC can be configured to automatically enter Sleep Mode after a conversion sequence, and can be triggered by the software. The ADC allows a data transfer with the PDC.

PMC: Power Management Controller

The AT91SAM7A2 Power Management Controller allows optimization of power consumption. The PMC enables/disables the clock inputs of the PDC and ARM core. Moreover, the main oscillator, the PLL and the analog peripherals can be put in standby mode allowing minimum power consumption to be obtained. The PMC provides the following operating modes:

- Normal: the clock generator provides clock to chip.
- Wait Mode: the ARM core clock is deactivated.
- Slow Mode: the clock generator is deactivated, the system is clocked at 32.768 kHz.

Each peripheral clock can be independently stopped or started directly in the peripheral to further reduce power consumption in Normal, Wait and Slow Modes.

ICE Debug Mode

ARM Standard Embedded In Circuit Emulation is supported via the ICE port. It is connected to a host computer via an external ICE Interface. In ICE Debug Mode the ARM core responds with a non-JTAG chip ID which identifies the core to the ICE system. This is not JTAG IEEE 1149.1 compliant.

Ordering Information

Table 3. Ordering Information

Ordering Code	Package	Temperature Operating Range
AT91SAM7A2-AI	TQFP 176	Industrial (-40°C to +85°C)

Packaging Information

Package Drawing

Figure 3. 176-lead LQFP Package Drawing

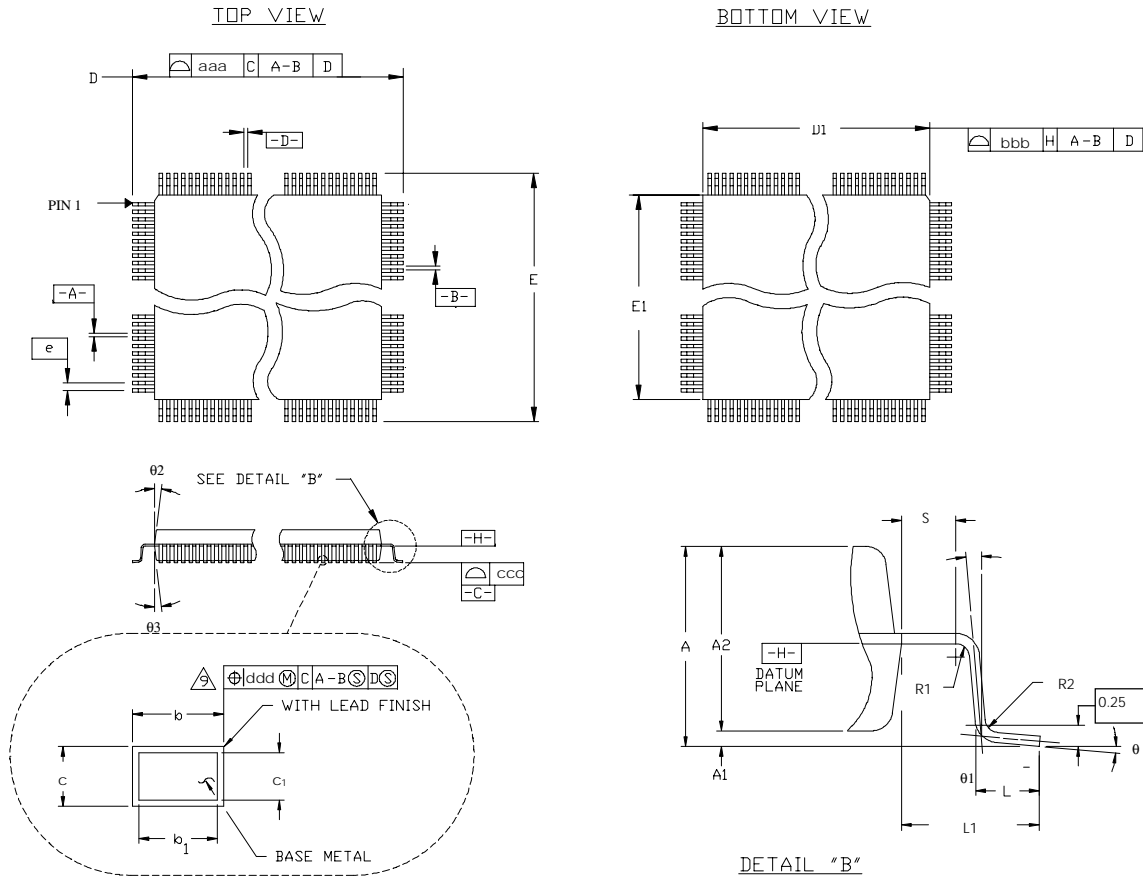

Table 4. Package Dimensions (mm)

Symbol	Min	Nom	Max
c	0.09		0.20
c1	0.09		0.16
L	0.45	0.6	0.75
L1	1.00 REF		
R2	0.08		0.2
R1	0.08		
S	0.2		
q	0°	3.5°	7°
θ1	0°		
θ2	11°	12°	13°
θ3	11°	12°	13°
A			1.6
A1	0.05		0.15
A2	1.35	1.4	1.45
Tolerances of Form and Position			
aaa		0.2	
bbb		0.2	

Table 5. Lead Count Dimensions (mm)

Pin Count	D/E BSC	D1/E1 BSC	b			b1			e BSC	ccc	ddd
			Min	Nom	Max	Min	Nom	Max			
176	26.0	24.0	0.17	0.20	0.27	0.17	0.20	0.23	0.50	0.10	0.08

Table 6. Device and 176-lead LQFP Package Maximum Weight

1900	mg
------	----

Soldering Profile

Table 7 gives the recommended soldering profile from J-STD-20.

Table 7. Soldering Profile

	Convection or IR/Convection	VPR
Average Ramp-up Rate (183°C to Peak)	3°C/sec. max.	10°C/sec.
Preheat Temperature 125°C ±25°C	120 sec. max	
Temperature Maintained Above 183°C	60 sec. to 150 sec.	
Time within 5°C of Actual Peak Temperature	10 sec. to 20 sec.	60 sec.
Peak Temperature Range	220 +5/-0°C or 235 +5/-0°C	215 to 219°C or 235 +5/-0°C
Ramp-down Rate	6°C/sec.	10°C/sec.
Time 25°C to Peak Temperature	6 min. max	

Small packages may be subject to higher temperatures if they are reflowed in boards with larger components. In this case, small packages may have to withstand temperatures of up to 235°C, not 220°C (IR reflow).

Recommended package reflow conditions depend on package thickness and volume. See Table 8 below.

Table 8. Recommended Package Reflow Conditions ^(1, 2, 3)

Parameter	Temperature
Convection	220 +5/-0°C
VPR	215 to 219°C
IR/Convection	220 +5/-0°C

Notes: 1. The packages are qualified by Atmel by using IR reflow conditions, not convection or VPR.
 2. By default, the package level 1 is qualified at 220°C (unless 235°C is stipulated).
 3. The body temperature is the most important parameter but other profile parameters such as total exposure time to hot temperature or heating rate may also influence component reliability.

A maximum of three reflow passes is allowed per component.

Document Details

Title AT91SAM7A2 - Summary

Literature Number 6021S

Revision History

Version AS **Publication Date:** 30-Mar-04

Version BS **Publication Date:** 06-Jul-04

Revisions Since Previous Version

Page: all Status changed to Preliminary

Page: 2 Block Diagram modified



Atmel Corporation

2325 Orchard Parkway
San Jose, CA 95131, USA
Tel: 1(408) 441-0311
Fax: 1(408) 487-2600

Regional Headquarters

Europe

Atmel Sarl
Route des Arsenaux 41
Case Postale 80
CH-1705 Fribourg
Switzerland
Tel: (41) 26-426-5555
Fax: (41) 26-426-5500

Asia

Room 1219
Chinachem Golden Plaza
77 Mody Road Tsimshatsui
East Kowloon
Hong Kong
Tel: (852) 2721-9778
Fax: (852) 2722-1369

Japan

9F, Tonetsu Shinkawa Bldg.
1-24-8 Shinkawa
Chuo-ku, Tokyo 104-0033
Japan
Tel: (81) 3-3523-3551
Fax: (81) 3-3523-7581

Atmel Operations

Memory

2325 Orchard Parkway
San Jose, CA 95131, USA
Tel: 1(408) 441-0311
Fax: 1(408) 436-4314

Microcontrollers

2325 Orchard Parkway
San Jose, CA 95131, USA
Tel: 1(408) 441-0311
Fax: 1(408) 436-4314

La Chantrerie
BP 70602
44306 Nantes Cedex 3, France
Tel: (33) 2-40-18-18-18
Fax: (33) 2-40-18-19-60

ASIC/ASSP/Smart Cards

Zone Industrielle
13106 Rousset Cedex, France
Tel: (33) 4-42-53-60-00
Fax: (33) 4-42-53-60-01

1150 East Cheyenne Mtn. Blvd.
Colorado Springs, CO 80906, USA
Tel: 1(719) 576-3300
Fax: 1(719) 540-1759

Scottish Enterprise Technology Park
Maxwell Building
East Kilbride G75 0QR, Scotland
Tel: (44) 1355-803-000
Fax: (44) 1355-242-743

RF/Automotive

Theresienstrasse 2
Postfach 3535
74025 Heilbronn, Germany
Tel: (49) 71-31-67-0
Fax: (49) 71-31-67-2340

1150 East Cheyenne Mtn. Blvd.
Colorado Springs, CO 80906, USA
Tel: 1(719) 576-3300
Fax: 1(719) 540-1759

**Biometrics/Imaging/Hi-Rel MPU/
High Speed Converters/RF Datacom**

Avenue de Rochepleine
BP 123
38521 Saint-Egreve Cedex, France
Tel: (33) 4-76-58-30-00
Fax: (33) 4-76-58-34-80



Literature Requests
www.atmel.com/literature

Disclaimer: Atmel Corporation makes no warranty for the use of its products, other than those expressly contained in the Company's standard warranty which is detailed in Atmel's Terms and Conditions located on the Company's web site. The Company assumes no responsibility for any errors which may appear in this document, reserves the right to change devices or specifications detailed herein at any time without notice, and does not make any commitment to update the information contained herein. No licenses to patents or other intellectual property of Atmel are granted by the Company in connection with the sale of Atmel products, expressly or by implication. Atmel's products are not authorized for use as critical components in life support devices or systems.

© Atmel Corporation 2004. All rights reserved. Atmel® and combinations thereof, are the registered trademarks of Atmel Corporation or its subsidiaries. ARM®, ARM7TDMI®, ARM®Thumb® and ARM Powered® are the registered trademarks and AMBA™ is the trademark of ARM Ltd. Other terms and product names may be the trademarks of others.