

1			2			3			4			5			6			7			8		
REVISIONS																							
ISS	ZONE	DESCRIPTION\PER REQUEST\DATE																					

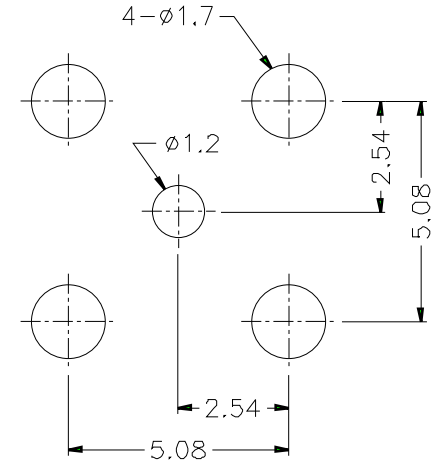
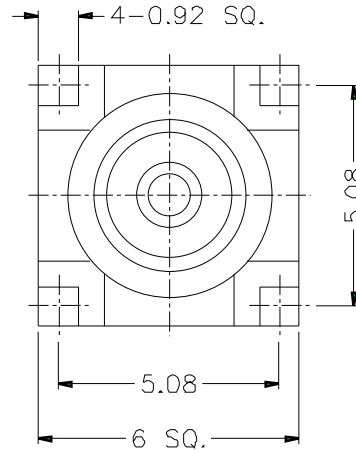
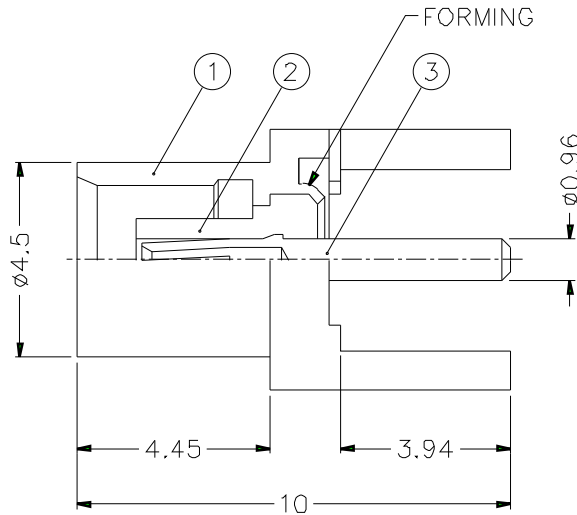

PCB MOUNTING HOLES

NOTES: FINISH (PLATING THICKNESS IN MICRO-INCHES)

1. BRASS PER QQ-B-626
2. GOLD PL. 3 MIN. THICK OVER NICKEL PL. 100 MIN. THICK OVER COPPER STRIKE
3. BERYLLIUM COPPER PER QQ-C-530
4. GOLD PL. 30 MIN. THICK OVER NICKEL PL. 100 MIN. THICK OVER COPPER STRIKE
5. TEFLON MIL-P-19468

DIMENSIONS ARE IN MILLIMETERS			
UNLESS OTHERWISE SPECIFIED TOLERANCES			
0.5-6	=	±0.2	
6-30	=	±0.4	
30-120	=	±0.6	
120-315	=	±1	
315-1000	=	±1.6	
1000-2000	=	±2.4	

PART NO.	MCX6251B1-3GT30G-50		
APPROVED	DATE	10-11-01'	
CHECKED	DATE	10-11-01'	
DRAWN	DATE	10-11-01'	

Amphenol	
TITLE	MCX P.C. BOARD RECEPT. JACK
DRAWING NO.	KJ-MCX6251B1-3GT30G-50
ITEM NO.	

3	CONTACT PIN	NOTE 3	NOTE 4	1	MCX6251B1-3-B
2	INSULATOR	NOTE 5	NATURAL	1	MXC6251B1-2T-50-B
1	BODY	NOTE 1	NOTE 2	1	MCX6251B1-1-B
NO.	DESCRIPTION	MATERIAL	FINISH	Q'TY	DRAWING NO.

SCALE	6/1	ISSUE	A	FILE NO	
-------	-----	-------	---	---------	--

1 2 3 4 5 6 7 8