



5V/3.3V 512K × 8 CMOS SRAM

Features

- AS7C4096 (5V version)
- AS7C34096 (3.3V version)
- Industrial and commercial temperature
- Organization: 524,288 words × 8 bits
- Center power and ground pins
- High speed
  - 10/12/15/20 ns address access time
  - 5/6/7/8 ns output enable access time
- Low power consumption: ACTIVE
  - 1375 mW (AS7C4096) / max @ 12 ns
  - 468 mW (AS7C34096) / max @ 12 ns

- Low power consumption: STANDBY
  - 110 mW (AS7C4096) / max CMOS
  - 72 mW (AS7C34096) / max CMOS
- Equal access and cycle times
- Easy memory expansion with  $\overline{CE}$ ,  $\overline{OE}$  inputs
- TTL-compatible, three-state I/O
- JEDEC standard packages
  - 400 mil 36-pin SOJ
  - 44-pin TSOP 2
- ESD protection  $\geq 2000$  volts
- Latch-up current  $\geq 200$  mA

Logic block diagram

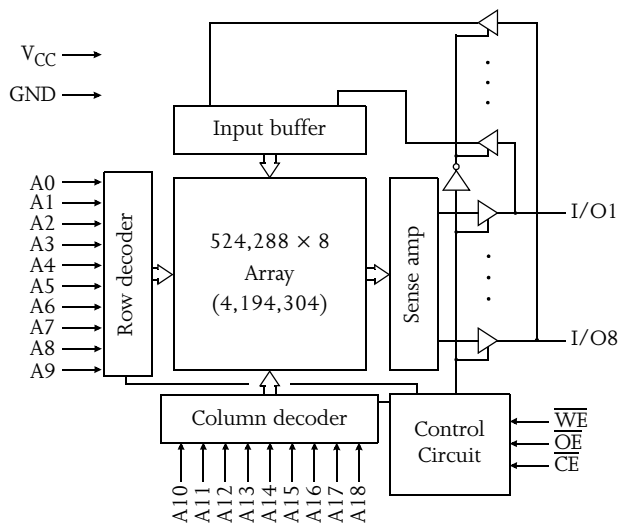

Pin arrangements

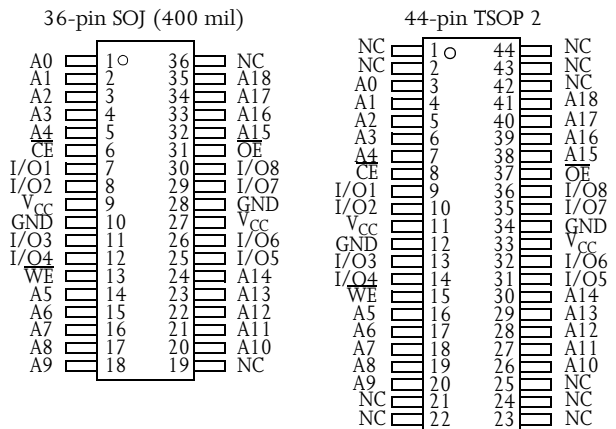

48-CSP/BGA Package

	1	2	3	4	5	6
A	A <sub>0</sub>	A <sub>1</sub>	NC	A <sub>3</sub>	A <sub>6</sub>	A <sub>8</sub>
B	I/O <sub>5</sub>	A <sub>2</sub>	$\overline{WE}$	A <sub>4</sub>	A <sub>7</sub>	I/O <sub>1</sub>
C	I/O <sub>6</sub>	NC	NC	A <sub>5</sub>	NC	I/O <sub>2</sub>
D	V <sub>SS</sub>	NC	NC	NC	NC	V <sub>CC</sub>
E	V <sub>CC</sub>	NC	NC	NC	NC	V <sub>SS</sub>
F	I/O <sub>7</sub>	NC	A <sub>18</sub>	A <sub>17</sub>	NC	I/O <sub>3</sub>
G	I/O <sub>8</sub>	$\overline{OE}$	$\overline{CS}$	A <sub>16</sub>	A <sub>15</sub>	I/O <sub>4</sub>
H	A <sub>9</sub>	A <sub>10</sub>	A <sub>11</sub>	A <sub>12</sub>	A <sub>13</sub>	A <sub>14</sub>

Selection guide

		-10	-12	-15	-20	Unit
Maximum address access time		10	12	15	20	ns
Maximum outputenable access time		5	6	7	9	ns
Maximum operating current	AS7C4096	-	250	220	180	mA
	AS7C34096	160	130	110	100	mA
Maximum CMOS standby current	AS7C4096	-	20	20	20	mA
	AS7C34096	20	20	20	20	mA



## Functional description

The AS7C4096 and AS7C34096 are high-performance CMOS 4,194,304-bit Static Random Access Memory (SRAM) devices organized as 524,288 words  $\times$  8 bits. They are designed for memory applications where fast data access, low power, and simple interfacing are desired.

Equal address access and cycle times ( $t_{AA}$ ,  $t_{RC}$ ,  $t_{WC}$ ) of 10/12/15/20 ns with output enable access times ( $t_{OE}$ ) of 5/6/7/8 ns are ideal for high-performance applications. The chip enable input  $\overline{CE}$  permits easy memory expansion with multiple-bank memory systems.

When  $\overline{CE}$  is high the device enters standby mode. The AS7C4096 is guaranteed not to exceed 110 mW power consumption in CMOS standby mode.

A write cycle is accomplished by asserting write enable ( $\overline{WE}$ ) and chip enable ( $\overline{CE}$ ). Data on the input pins I/O1–I/O8 is written on the rising edge of  $\overline{WE}$  (write cycle 1) or  $\overline{CE}$  (write cycle 2). To avoid bus contention, external devices should drive I/O pins only after outputs have been disabled with output enable ( $\overline{OE}$ ) or write enable ( $\overline{WE}$ ).

A read cycle is accomplished by asserting output enable ( $\overline{OE}$ ) and chip enable ( $\overline{CE}$ ), with write enable ( $\overline{WE}$ ) high. The chip drives I/O pins with the data word referenced by the input address. When either chip enable or output enable is inactive, or write enable is active, output drivers stay in high-impedance mode.

All chip inputs and outputs are TTL-compatible, and operation is from a single supply voltage. Both devices are available in the industry standard 400-mil 36-pin SOJ and 44-pin TSOP 2 packages.

## Absolute maximum ratings

Parameter	Device	Symbol	Min	Max	Unit
Voltage on $V_{CC}$ relative to GND	AS7C4096	$V_{t1}$	-1	+7.0	V
	AS7C34096	$V_{t1}$	-0.5	+5.0	V
Voltage on any pin relative to GND		$V_{t2}$	-0.5	$V_{CC} + 0.5$	V
Power dissipation		$P_D$	-	1.0	W
Storage temperature (plastic)		$T_{stg}$	-65	+150	$^{\circ}C$
Temperature with $V_{CC}$ applied		$T_{bias}$	-55	+125	$^{\circ}C$
DC current unto output (low)		$I_{OUT}$	-	20	mA

NOTE: Stresses greater than those listed under *Absolute Maximum Ratings* may cause permanent damage to the device. This is a stress rating only and functional operation of the device at these or any other conditions outside those indicated in the operational sections of this specification is not implied. Exposure to absolute maximum rating conditions for extended periods may affect reliability.

## Truth table

CE	WE	OE	Data	Mode
H	X	X	High Z	Standby ( $I_{SB}$ , $I_{SB1}$ )
L	H	H	High Z	Output disable ( $I_{CC}$ )
L	H	L	$D_{OUT}$	Read ( $I_{CC}$ )
L	L	X	$D_{IN}$	Write ( $I_{CC}$ )

Key: X = Don't care, L = Low, H = High



### Recommended operating condition

Parameter		Device	Symbol	Min	Nominal	Max	Unit
Supply voltage		AS7C4096	$V_{CC}(12/15/20)$	4.5	5.0	5.5	V
		AS7C34096	$V_{CC}(-10)$	3.15	3.30	3.6	V
		AS7C34096	$V_{CC}(12/15/20)$	3.0	3.3	3.6	V
Input voltage		AS7C4096	$V_{IH}$	2.2	–	$V_{CC} + 0.5$	V
		AS7C34096	$V_{IH}$	2.0	–	$V_{CC} + 0.5$	V
			$V_{IL}$	$-0.5^{\dagger}$	–	0.8	V
Ambient operating temperature	commercial		$T_A$	0	–	70	°C
	industrial		$T_A$	-40	–	85	°C

<sup>†</sup>  $V_{IL}$  min = -3.0V for pulse width less than  $t_{RC}/2$ .

### DC operating characteristics (over the operating range)<sup>1</sup>

Parameter	Symbol	Test conditions	Device	-10		-12		-15		-20		Unit
				Min	Max	Min	Max	Min	Max	Min	Max	
Input leakage current	$ I_{LI} $	$V_{CC} = \text{Max}, V_{IN} = \text{GND to } V_{CC}$		–	1	–	1	–	1	–	1	μA
Output leakage current	$ I_{LO} $	$V_{CC} = \text{Max}, \overline{CE} = V_{IH}$ $V_{OUT} = \text{GND to } V_{CC}$		–	1	–	1	–	1	–	1	μA
Operating power supply current	$I_{CC}$	$V_{CC} = \text{Max}, \overline{CE} < V_{IL}$ $f = f_{\text{Max}}, I_{OUT} = 0\text{mA}$	AS7C4096	–	–	–	250	–	220	–	180	mA
			AS7C34096	–	160	–	130	–	110	–	100	
Standby power supply current	$I_{SB}$	$V_{CC} = \text{Max}, \overline{CE} = V_{IH}$ $f = f_{\text{Max}}, I_{OUT} = 0\text{mA}$	AS7C4096	–	–	–	60	–	60	–	60	mA
			AS7C34096	–	60	–	60	–	60	–	60	
	$I_{SB1}$	$V_{CC} = \text{Max},$ $\overline{CE} \geq V_{CC} - 0.2\text{V}, V_{IN} \leq 0.2\text{V}$ or $V_{IN} \geq V_{CC} - 0.2\text{V}, f = 0$	AS7C4096	–	–	–	20	–	20	–	20	mA
			AS7C34096	–	20	–	20	–	20	–	20	
Output voltage	$V_{OL}$	$I_{OL} = 8 \text{ mA}, V_{CC} = \text{Min}$		–	0.4	–	0.4	–	0.4	–	0.4	V
	$V_{OH}$	$I_{OH} = -4 \text{ mA}, V_{CC} = \text{Min}$		2.4	–	2.4	–	2.4	–	2.4	–	V

### Capacitance ( $f = 1\text{MHz}, T_a = 25^\circ \text{C}, V_{CC} = \text{NOMINAL}$ )<sup>2</sup>

Parameter	Symbol	Signals	Test conditions	Max	Unit
Input capacitance	$C_{IN}$	A, $\overline{CE}$ , $\overline{WE}$ , $\overline{OE}$	$V_{IN} = 0\text{V}$	5	pF
I/O capacitance	$C_{I/O}$	I/O	$V_{IN} = V_{OUT} = 0\text{V}$	7	pF



Read cycle (over the operating range)<sup>3,9</sup>

Parameter	Symbol	-10		-12		-15		-20		Unit	Notes
		Min	Max	Min	Max	Min	Max	Min	Max		
Read cycle time	$t_{RC}$	10	–	12	–	15	–	20	–	ns	
Address access time	$t_{AA}$	–	10	–	12	–	15	–	20	ns	3
Chip enable ( $\overline{CE}$ ) access time	$t_{ACE}$	–	10	–	12	–	15	–	20	ns	3
Output enable ( $\overline{OE}$ ) access time	$t_{OE}$	–	5	–	6	–	7	–	8	ns	
Output hold from address change	$t_{OH}$	3	–	3	–	3	–	3	–	ns	5
$\overline{CE}$ Low to output in low Z	$t_{CLZ}$	3	–	3	–	0	–	0	–	ns	4, 5
$\overline{CE}$ High to output in high Z	$t_{CHZ}$	–	5	–	6	–	7	–	9	ns	4, 5
$\overline{OE}$ Low to output in low Z	$t_{OLZ}$	0	–	0	–	0	–	0	–	ns	4, 5
$\overline{OE}$ High to output in high Z	$t_{OHZ}$	–	5	–	6	–	7	–	9	ns	4, 5
Power up time	$t_{PU}$	0	–	0	–	0	–	0	–	ns	4, 5
Power down time	$t_{PD}$	–	10	–	12	–	15	–	20	ns	4, 5

Key to switching waveforms



Read waveform 1 (address controlled)<sup>3,6,7,9</sup>

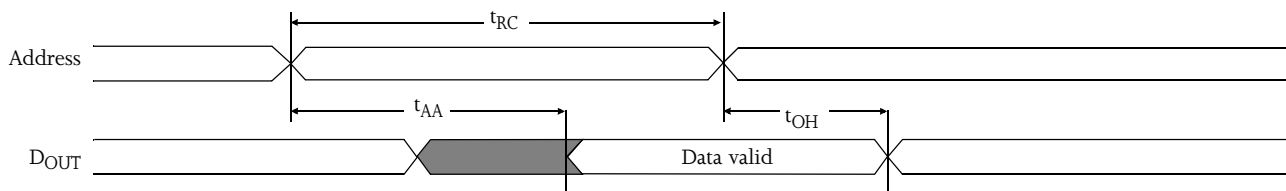

Read waveform 2 ( $\overline{CE}$ ,  $\overline{OE}$  controlled)<sup>3,6,8,9</sup>

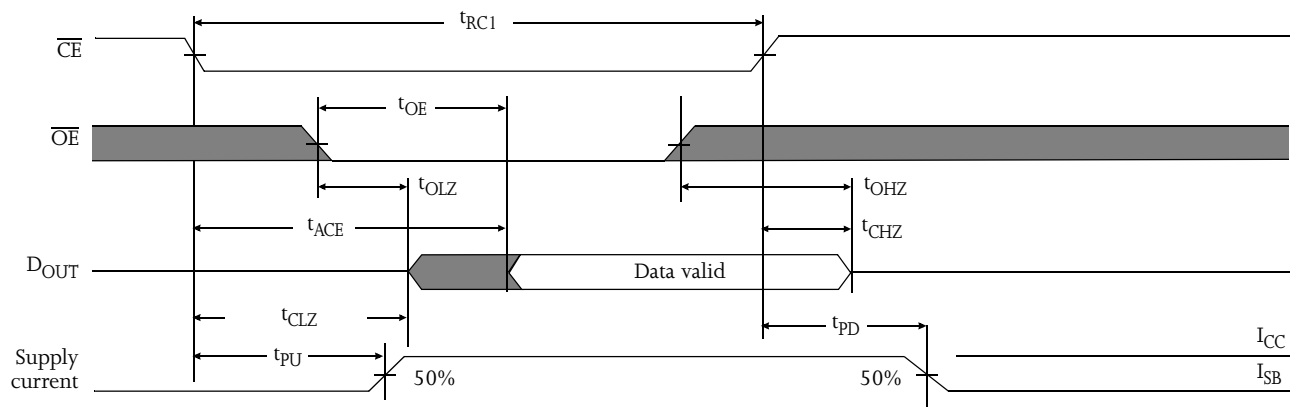



Write cycle (over the operating range)<sup>11</sup>

Parameter	Symbol	-10		-12		-15		-20		Unit	Notes
		Min	Max	Min	Max	Min	Max	Min	Max		
Write cycle time	$t_{WC}$	10	–	12	–	15	–	20	–	ns	
Chip enable ( $\overline{CE}$ ) to write end	$t_{CW}$	7	–	8	–	10	–	12	–	ns	
Address setup to write end	$t_{AW}$	7	–	8	–	10	–	12	–	ns	
Address setup time	$t_{AS}$	0	–	0	–	0	–	0	–	ns	
Write pulse width ( $\overline{OE} = \text{high}$ )	$t_{WP1}$	7	–	8	–	10	–	12	–	ns	
Write pulse width ( $\overline{OE} = \text{low}$ )	$t_{WP2}$	10	–	12	–	15	–	20	–	ns	
Address hold from end of write	$t_{AH}$	0	–	0	–	0	–	0	–	ns	
Write recovery time	$t_{WR}$	0	–	0	–	0	–	0	–	ns	
Data valid to write end	$t_{DW}$	5	–	6	–	7	–	9	–	ns	
Data hold time	$t_{DH}$	0	–	0	–	0	–	0	–	ns	4, 5
Write enable to output in high Z	$t_{WZ}$	0	5	0	6	0	7	0	9	ns	4, 5
Output active from write end	$t_{OW}$	3	–	3	–	3	–	3	–	ns	4, 5

Write waveform 1 ( $\overline{WE}$  controlled)<sup>10,11</sup>

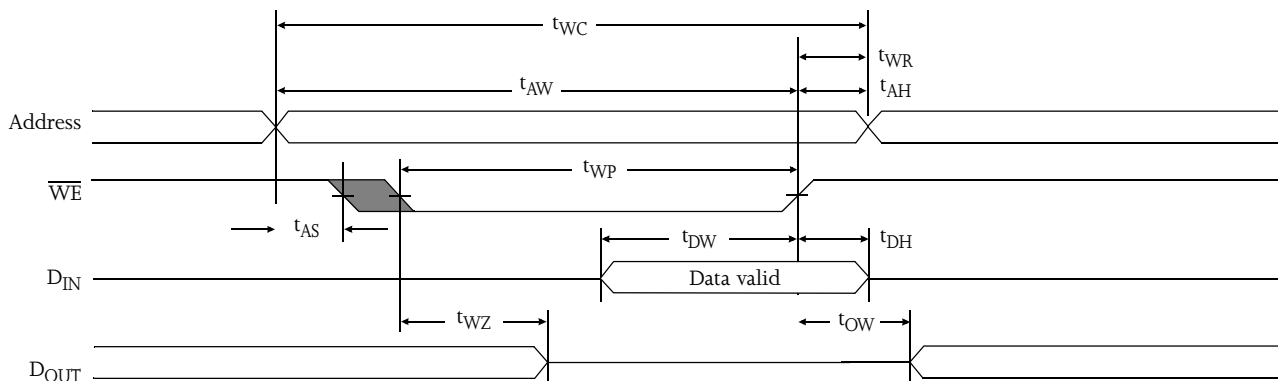

Write waveform 2 ( $\overline{CE}$  controlled)<sup>10,11</sup>

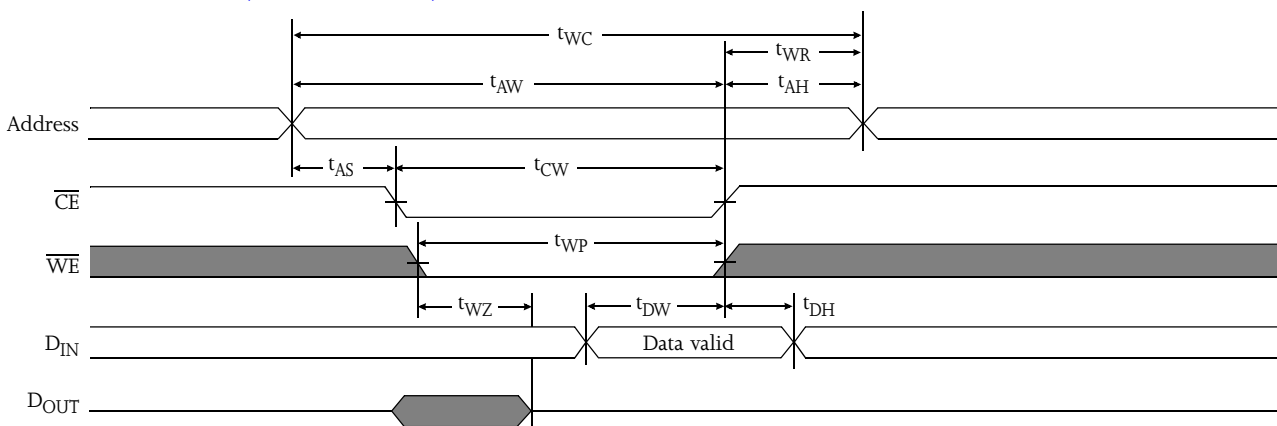



## AC test conditions

- Output load: see Figure B or Figure C.
- Input pulse level: GND to 3.0V. See Figures A, B, and C.
- Input rise and fall times: 2 ns. See Figure A.
- Input and output timing reference levels: 1.5V.

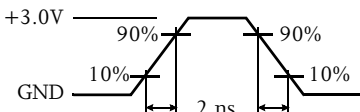

Figure A: Input pulse

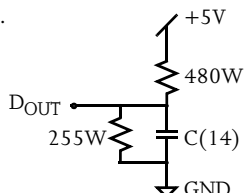

Figure B: 5V Output load

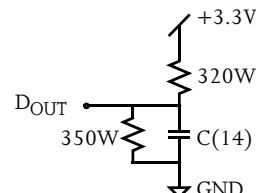
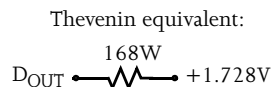

Figure C: 3.3V Output load

## Notes

- 1 During  $V_{CC}$  power-up, a pull-up resistor to  $V_{CC}$  on  $\overline{CE}$  is required to meet  $I_{SB}$  specification.
- 2 This parameter is sampled, but not 100% tested.
- 3 For test conditions, see AC Test Conditions.
- 4  $t_{CLZ}$  and  $t_{CHZ}$  are specified with  $C_L = 5\text{pF}$  as in Figure C. Transition is measured  $\pm 500\text{ mV}$  from steady-state voltage.
- 5 This parameter is guaranteed, but not tested.
- 6  $\overline{WE}$  is HIGH for read cycle.
- 7  $\overline{CE}$  and  $\overline{OE}$  are LOW for read cycle.
- 8 Address valid prior to or coincident with  $\overline{CE}$  transition Low.
- 9 All read cycle timings are referenced from the last valid address to the first transitioning address.
- 10  $\overline{CE}$  or  $\overline{WE}$  must be HIGH during address transitions. Either  $\overline{CE}$  or  $\overline{WE}$  asserting high terminates a write cycle.
- 11 All write cycle timings are referenced from the last valid address to the first transitioning address.
- 12 Not applicable.
- 13  $C = 30\text{pF}$ , except at high Z and low Z parameters, where  $C = 5\text{pF}$ .



Typical DC and AC characteristics 12

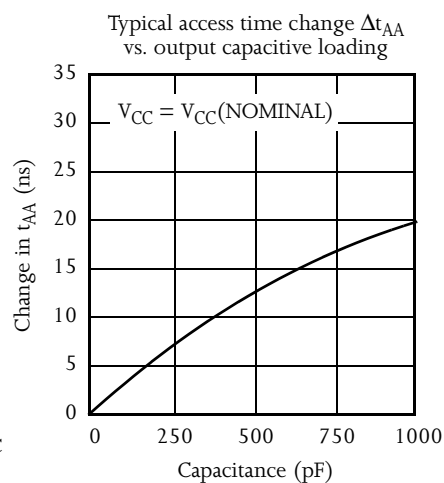
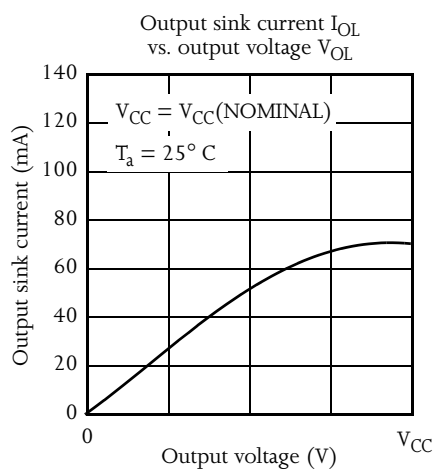
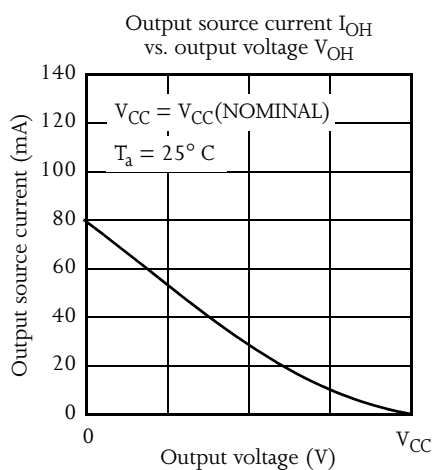
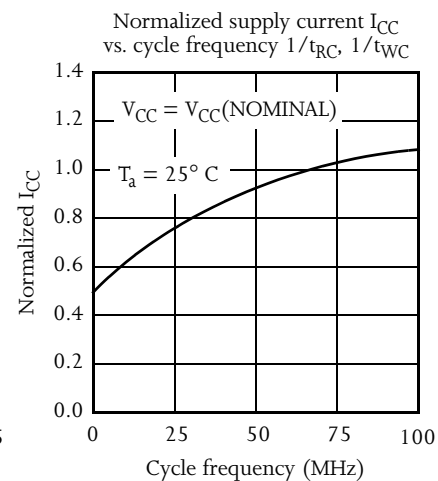
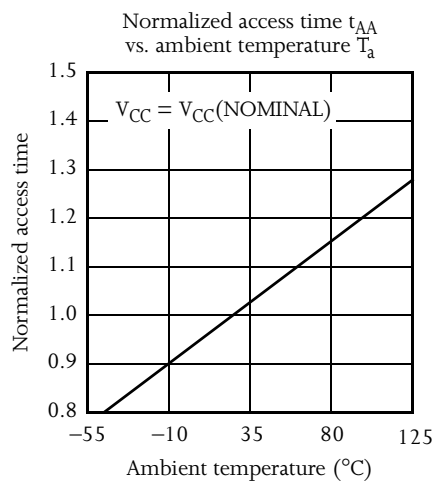
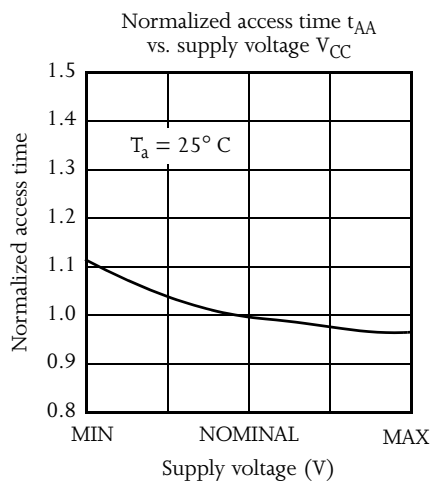
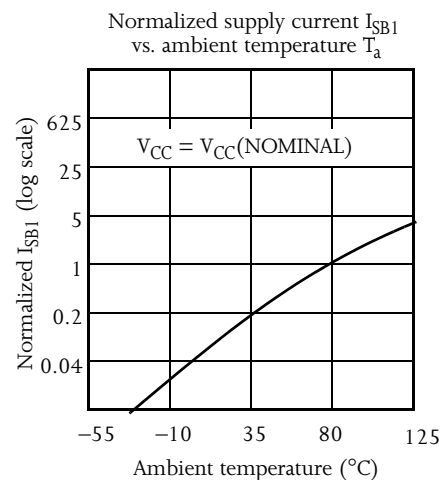
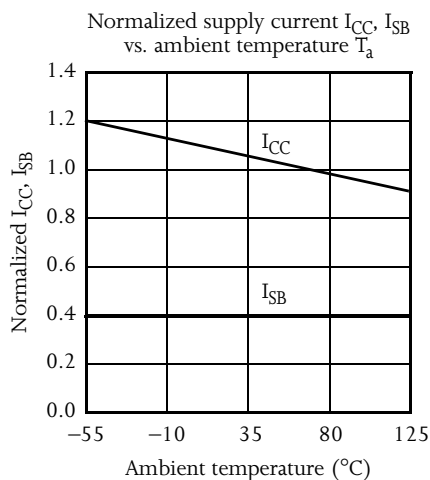
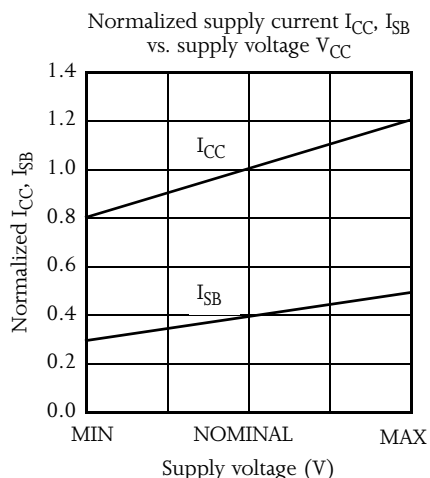



Package dimensions

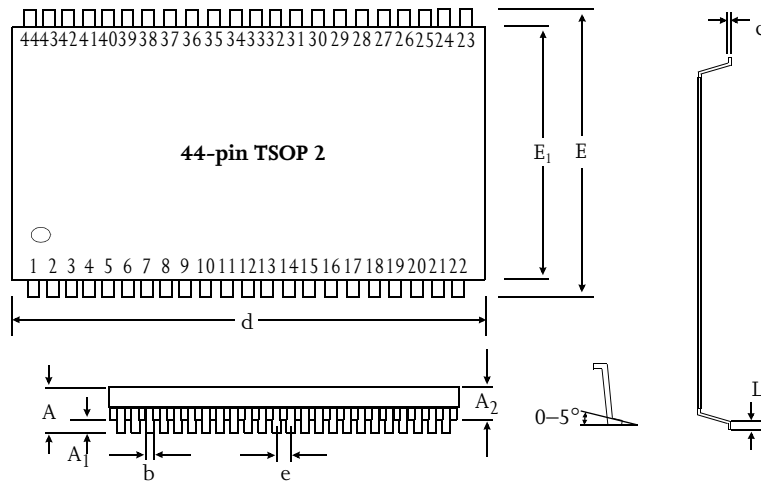

	44-pin TSOP 2	
	Min (mm)	Max (mm)
A		1.2
A <sub>1</sub>	0.05	0.15
A <sub>2</sub>	0.95	1.05
b	0.30	0.45
c	0.15 (typical)	
d	18.28	18.54
E <sub>1</sub>	10.03	10.16
E	11.56	11.96
e	0.80 (typical)	
L	0.40	0.60

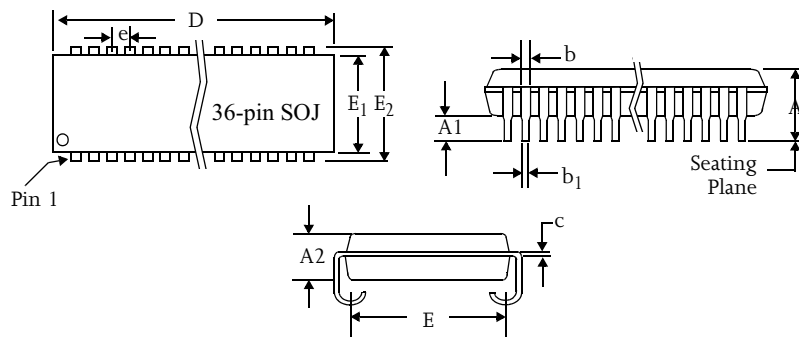

	36-pin SOJ 400	
	Min (mils)	Max (mils)
A	.128	0.148
A <sub>1</sub>	0.027	-
A <sub>2</sub>	0.102 NOM	
b	0.015	0.020
b <sub>1</sub>	0.026	0.032
c	0.007	0.013
D	.920	.930
e	0.045	0.055
E	0.400 NOM	
E	0.435	0.445



48-ball FBGA

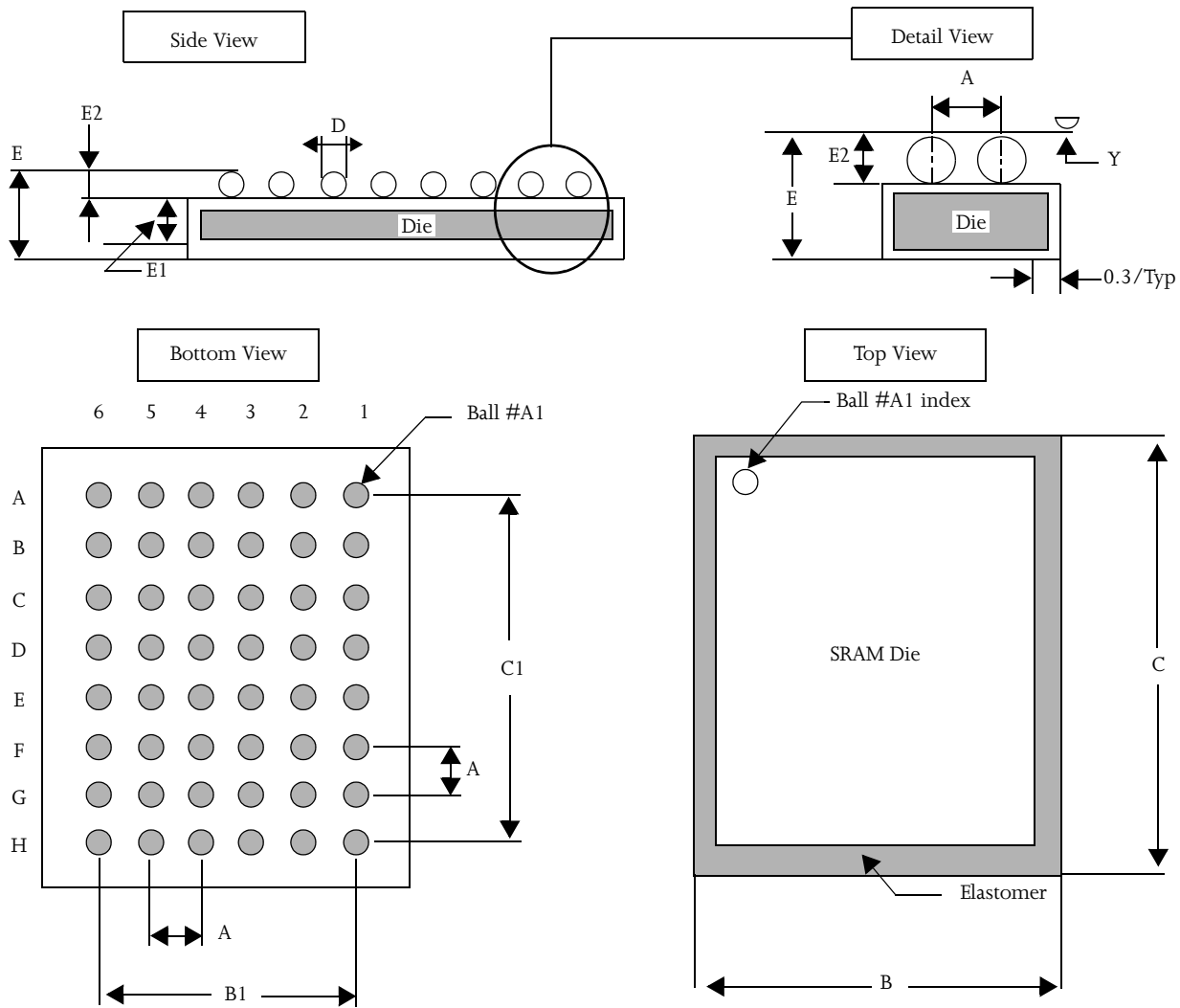

Notes

1. Bump counts: 48 (8 row × 6 column).
2. Pitch: (x,y) = 0.75 mm × 0.75 mm (typ).
3. Units: millimeters.
4. All tolerance are ±0.050 unless otherwise specified.
5. Typ: typical.
6. Y is coplanarity: 0.08 (max).

48-ball FBGA			
	Minimum	Typical	Maximum
A	—	0.75	—
B	6.90	7.00	7.10
B1	—	3.75	—
C	10.90	11.00	11.10
C1	—	5.25	—
D	0.30	0.35	0.40
E	—	—	1.20
E1	—	0.68	—
E2	0.22	0.25	0.27
Y	—	—	0.08



## Ordering codes

Package	Version	10 ns	12 ns	15 ns	20 ns
SOJ	5V commercial	NA	AS7C4096-12JC	AS7C4096-15JC	AS7C4096-20JC
	5V industrial	NA	AS7C4096-12JI	AS7C4096-15JI	AS7C4096-20JI
	3.3V commercial	AS7C34096-10JC	AS7C34096-12JC	AS7C34096-15JC	AS7C34096-20JC
	3.3V industrial	NA	AS7C34096-12JI	AS7C34096-15JI	AS7C34096-20JI
TSOP 2	5V commercial	NA	AS7C4096-12TC	AS7C4096-15TC	AS7C4096-20TC
	5V industrial	NA	AS7C4096-12TI	AS7C4096-15TI	AS7C4096-20TI
	3.3V commercial	AS7C34096-10TC	AS7C34096-12TC	AS7C34096-15TC	AS7C34096-20TC
	3.3V industrial	NA	AS7C34096-12TI	AS7C34096-15TI	AS7C34096-20TI
BGA	5V commercial	NA	AS7C4096-12BC	AS7C4096-15BC	AS7C4096-20BC
	5V industrial	NA	AS7C4096-12BI	AS7C4096-15BI	AS7C4096-20BI
	3.3V commercial	AS7C34096-10BC	AS7C34096-12BC	AS7C34096-15BC	AS7C34096-20BC
	3.3V industrial	NA	AS7C34096-12BI	AS7C34096-15BI	AS7C34096-20BI

## Part numbering system

AS7C	X	4096	-XX	J, T, B	X
SRAM prefix	Voltage: Blank = 5V CMOS 3 = 3.3V CMOS	Device number	Access time	Package: J: 400-mil SOJ T: TSOP 2 B: BGA	Temperature ranges: C: Commercial, 0° C to 70° C I: Industrial, -40° C to 85° C