

Typical Fault Protected IGBT Gate Drive Circuit

The HCPL-316J is an easy-to-use, intelligent gate driver which makes IGBT V_{CE} fault protection compact, affordable, and easy-to-implement. Features such as

user configurable inputs, integrated V_{CE} detection, under voltage lockout (UVLO), “soft” IGBT turn-off and isolated fault feedback provide maximum design flexibility and circuit protection.

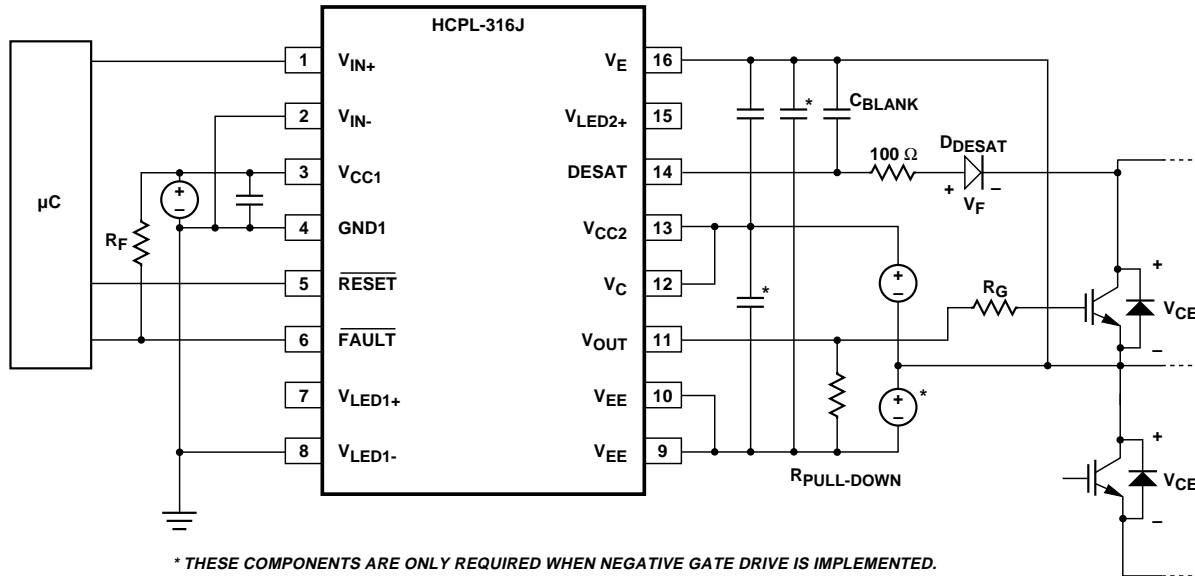

Figure 1. Typical desaturation protected gate drive circuit, noninverting.

Description of Operation during Fault Condition

1. DESAT terminal monitors the IGBT V_{CE} voltage through D_{DESAT} .
2. When the voltage on the DESAT terminal exceeds 7 volts, the IGBT gate voltage (V_{OUT}) is slowly lowered.
3. \overline{FAULT} output goes low, notifying the microcontroller of the fault condition.
4. Microcontroller takes appropriate action.

Output Control

The outputs (V_{OUT} and \overline{FAULT}) of the HCPL-316J are controlled by the combination of V_{IN} , UVLO and a detected IGBT Desat condition. As indicated in the below table, the HCPL-316J can

be configured as inverting or non-inverting using the V_{IN+} or V_{IN-} inputs respectively. When an inverting configuration is desired, V_{IN+} must be held high and V_{IN-} toggled. When a non-inverting configuration is desired, V_{IN-} must be held low and V_{IN+} toggled. Once UVLO is not active ($V_{CC2} - V_E > V_{UVLO}$), V_{OUT} is allowed to go high, and

the DESAT (pin 14) detection feature of the HCPL-316J will be the primary source of IGBT protection. UVLO is needed to ensure DESAT is functional. Once $V_{UVLO+} > 11.6$ V, DESAT will remain functional until $V_{UVLO-} < 12.4$ V. Thus, the DESAT detection and UVLO features of the HCPL-316J work in conjunction to ensure constant IGBT protection.

V_{IN+}	V_{IN-}	UVLO ($V_{CC2} - V_E$)	Desat Condition Detected on Pin 14	Pin 6 (\overline{FAULT}) Output	V_{OUT}
X	X	Active	X	X	Low
X	X	X	Yes	Low	Low
Low	X	X	X	X	Low
X	High	X	X	X	Low
High	Low	Not Active	No	High	High

Product Overview Description

The HCPL-316J is a highly integrated power control device that incorporates all the necessary components for a complete, isolated IGBT gate drive circuit with fault protection and feedback into one SO-16 package. TTL input logic levels allow direct interface with a microcontroller, and an optically isolated power output stage drives IGBTs with power ratings of up to 150 A and 1200 V. A high speed internal optical link minimizes the propagation delays between the microcontroller and the IGBT while allowing the two systems to operate at very large common mode voltage differences that are common in industrial motor drives and other power switching applications. An output IC provides local

protection for the IGBT to prevent damage during overcurrents, and a second optical link provides a fully isolated fault status feedback signal for the microcontroller. A built in “watchdog” circuit monitors the power stage supply voltage to prevent IGBT caused by insufficient gate drive voltages. This integrated IGBT gate driver is designed to increase the performance and reliability of a motor drive without the cost, size, and complexity of a discrete design.

Two light emitting diodes and two integrated circuits housed in the same SO-16 package provide the input control circuitry, the output power stage, and two optical channels. The input Buffer IC is designed on a bipolar process, while the

output Detector IC is designed manufactured on a high voltage BiCMOS/Power DMOS process. The forward optical signal path, as indicated by LED1, transmits the gate control signal. The return optical signal path, as indicated by LED2, transmits the fault status feedback signal. Both optical channels are completely controlled by the input and output ICs respectively, making the internal isolation boundary transparent to the microcontroller.

Under normal operation, the input gate control signal directly controls the IGBT gate through the isolated output detector IC. LED2 remains off and a fault latch in the input buffer IC is disabled. When an IGBT fault is detected, the output detector IC immediately begins a “soft” shutdown sequence, reducing the IGBT current to zero in a controlled manner to avoid potential IGBT damage from inductive overvoltages. Simultaneously, this fault status is transmitted back to the input buffer IC via LED2, where the fault latch disables the gate control input and the active low fault output alerts the microcontroller.

During power-up, the Under Voltage Lockout (UVLO) feature prevents the application of insufficient gate voltage to the IGBT, by forcing the HCPL-316J’s output low. Once the output is in the high state, the DESAT (V_{CE}) detection feature of the HCPL-316J provides IGBT protection. Thus, UVLO and DESAT work in conjunction to provide constant IGBT protection.

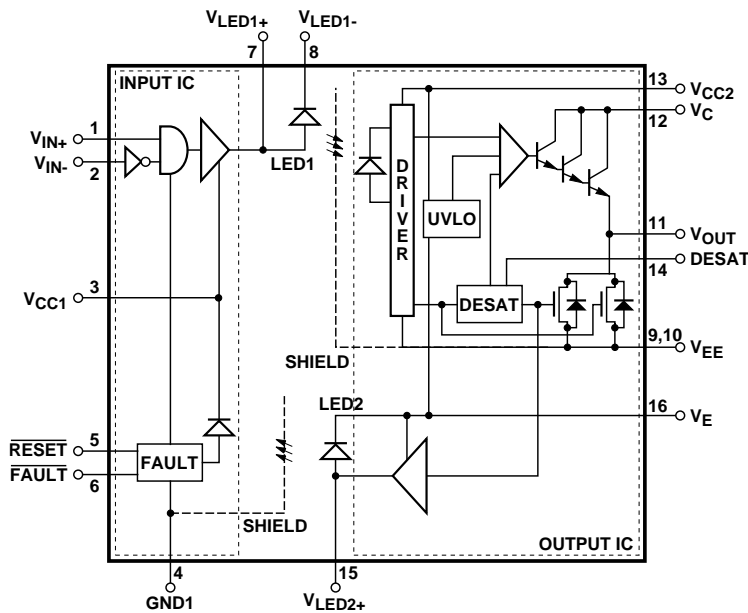

Package Pin Out

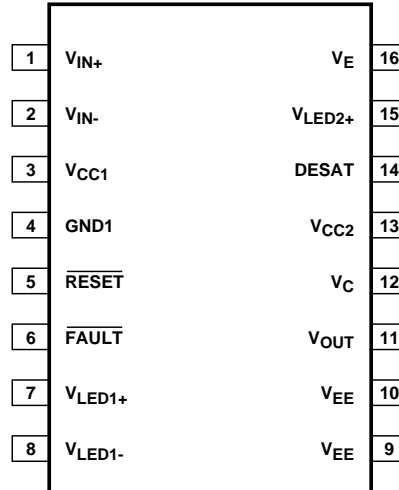

Pin Descriptions

Symbol	Description	Symbol	Description
V _{IN+}	Noninverting gate drive voltage output (V _{OUT}) control input.	V _E	Common (IGBT emitter) output supply voltage.
V _{IN-}	Inverting gate drive voltage output (V _{OUT}) control input.	V _{LED2+}	LED 2 anode. This pin must be left unconnected for guaranteed data sheet performance. (For optical coupling testing only.)
V _{CC1}	Positive input supply voltage. (4.5 V to 5.5 V)	DESAT	Desaturation voltage input. When the voltage on DESAT exceeds an internal reference voltage of 7 V while the IGBT is on, FAULT output is changed from a high impedance state to a logic low state within 5 μs. See Note 25.
GND1	Input Ground.	V _{CC2}	Positive output supply voltage.
RESET	FAULT reset input. A logic low input for at least 0.1 μs, asynchronously resets FAULT output high and enables V _{IN} . Synchronous control of RESET relative to V _{IN} is required. RESET is not affected by UVLO. Asserting RESET while V _{OUT} is high does not affect V _{OUT} .	V _C	Collector of output pull-up triple-darlington transistor. It is connected to V _{CC2} directly or through a resistor to limit output turn-on current.
FAULT	Fault output. FAULT changes from a high impedance state to a logic low output within 5 μs of the voltage on the DESAT pin exceeding an internal reference voltage of 7 V. FAULT output remains low until RESET is brought low. FAULT output is an open collector which allows the FAULT outputs from all HCPL-316Js in a circuit to be connected together in a "wired OR" forming a single fault bus for interfacing directly to the micro-controller.	V _{OUT}	Gate drive voltage output.
V _{LED1+}	LED 1 anode. This pin must be left unconnected for guaranteed data sheet performance. (For optical coupling testing only.)	V _{EE}	Output supply voltage.
V _{LED1-}	LED 1 cathode. This pin must be connected to ground.		

Ordering Information

Specify Part Number followed by Option Number (if desired).

Example:

HCPL-316J#XXXX

- No Option = 16-Lead, Surface Mt. package, 45 per tube.
- 500 = Tape and Reel Packaging Option, 850 per reel.
- XXXE = Lead Free Option.

Remarks: The notation “#” is used for existing products, while (new) products launched since 15th July 2001 and lead free option will use “-”

Option data sheets available. Contact Agilent sales representative, authorized distributor, or visit our WEB site at <http://www.agilent.com/view/optocouplers>.

Package Outline Drawings

16-Lead Surface Mount

Dimensions in inches
(millimeters)

Notes:

Initial and continued variation in the color of the HCPL-316J's white mold compound is normal and does not affect device performance or reliability.

Floating Lead
Protrusion is 0.25 mm
(10 mils) max.

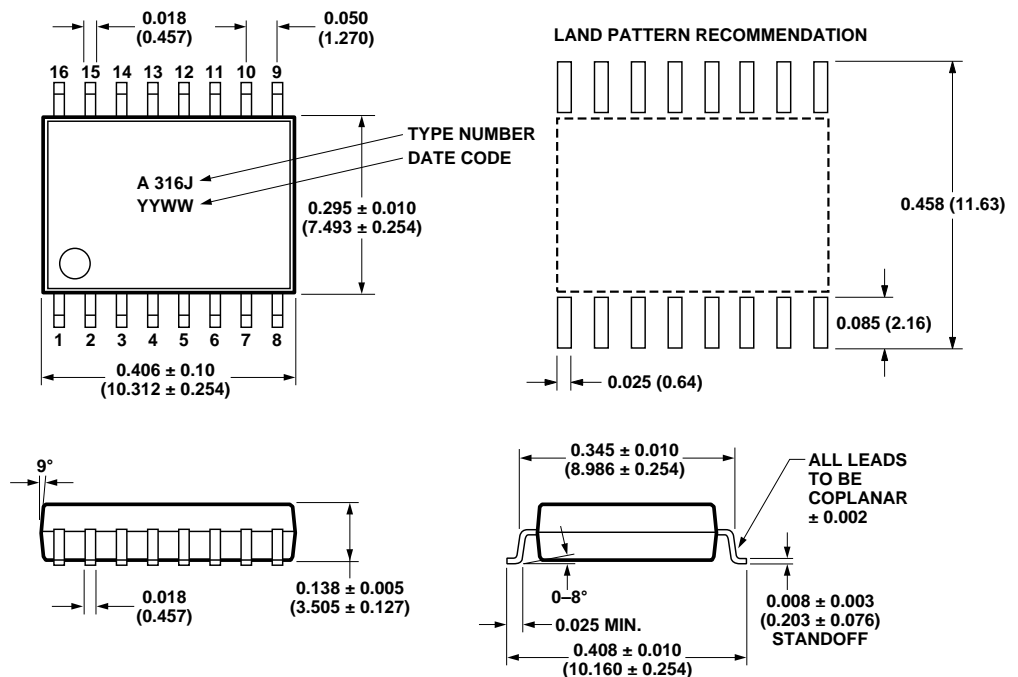

Package Characteristics

All specifications and figures are at the nominal (typical) operating conditions of $V_{CC1} = 5\text{ V}$, $V_{CC2} - V_{EE} = 30\text{ V}$, $V_E - V_{EE} = 0\text{ V}$, and $T_A = +25^\circ\text{C}$.

Parameter	Symbol	Min.	Typ.	Max.	Units	Test Conditions	Note
Input-Output Momentary Withstand Voltage	V_{ISO}	3750			V_{rms}	RH < 50%, t = 1 min., $T_A = 25^\circ\text{C}$	1, 2, 3
Resistance (Input-Output)	R_{I-O}		$>10^9$		Ω	$V_{I-O} = 500\text{ Vdc}$	3
Capacitance (Input-Output)	C_{I-O}		1.3		pF	f = 1 MHz	
Output IC-to-Pins 9 & 10 Thermal Resistance	θ_{09-10}		30		$^\circ\text{C/W}$	$T_A = 100^\circ\text{C}$	
Input IC-to-Pin 4 Thermal Resistance	θ_{I4}		60				

Solder Reflow Thermal Profile

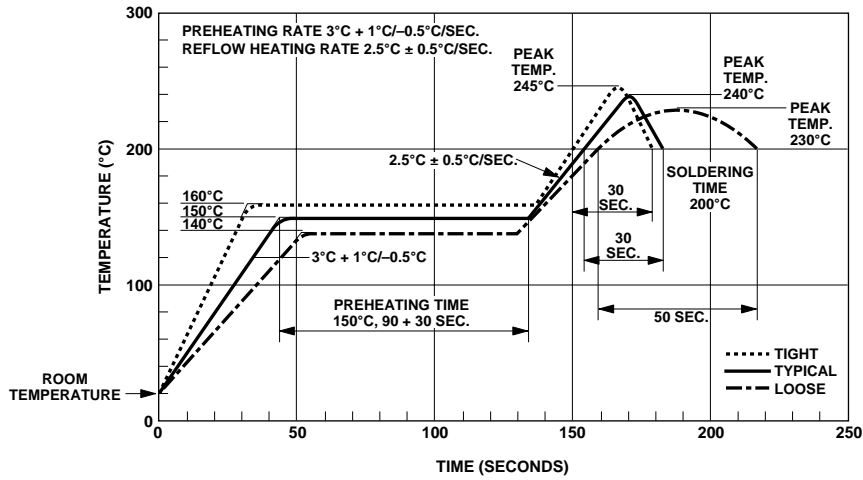

Recommended Pb-Free IR Profile

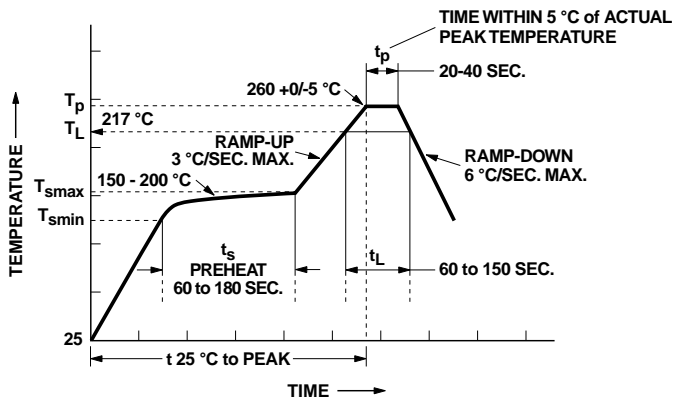

NOTES:
 THE TIME FROM 25°C TO PEAK TEMPERATURE = 8 MINUTES MAX.
 $T_{smax} = 200^{\circ}\text{C}$, $T_{smin} = 150^{\circ}\text{C}$

Regulatory Information

The HCPL-316J has been approved by the following organizations:

IEC/EN/DIN EN 60747-5-2

Approved under:
IEC 60747-5-2:1997 + A1:2002
EN 60747-5-2:2001 + A1:2002
DIN EN 60747-5-2 (VDE 0884 Teil 2):2003-01.

UL

Recognized under UL 1577, component recognition program, File E55361.

CSA

Approved under CSA Component Acceptance Notice #5, File CA 88324.

IEC/EN/DIN EN 60747-5-2 Insulation Characteristics*

Description	Symbol	Characteristic	Unit
Installation classification per DIN VDE 0110/1.89, Table 1 for rated mains voltage ≤ 150 Vrms for rated mains voltage ≤ 300 Vrms for rated mains voltage ≤ 600 Vrms		I - IV I - III I - II	
Climatic Classification		55/100/21	
Pollution Degree (DIN VDE 0110/1.89)		2	
Maximum Working Insulation Voltage	V_{IORM}	891	V_{PEAK}
Input to Output Test Voltage, Method b** $V_{IORM} \times 1.875 = V_{PR}$, 100% Production Test with $t_m = 1$ sec, Partial Discharge < 5 pC	V_{PR}	1670	V_{PEAK}
Input to Output Test Voltage, Method a** $V_{IORM} \times 1.5 = V_{PR}$, Type and Sample Test, $t_m = 60$ sec, Partial Discharge < 5 pC	V_{PR}	1336	V_{PEAK}
Highest Allowable Overvoltage** (Transient Overvoltage $t_{ini} = 10$ sec)	V_{IOTM}	6000	V_{PEAK}
Safety-limiting values – maximum values allowed in the event of a failure, also see Figure 2.			
Case Temperature	T_S	175	$^{\circ}C$
Input Power	$P_{S, INPUT}$	400	mW
Output Power	$P_{S, OUTPUT}$	1200	mW
Insulation Resistance at T_S , $V_{IO} = 500$ V	R_S	$>10^9$	Ω

*Isolation characteristics are guaranteed only within the safety maximum ratings which must be ensured by protective circuits in application. Surface mount classification is class A in accordance with CECC00802.

**Refer to the optocoupler section of the Isolation and Control Components Designer's Catalog, under Product Safety Regulations section IEC/EN/DIN EN 60747-5-2, for a detailed description of Method a and Method b partial discharge test profiles.

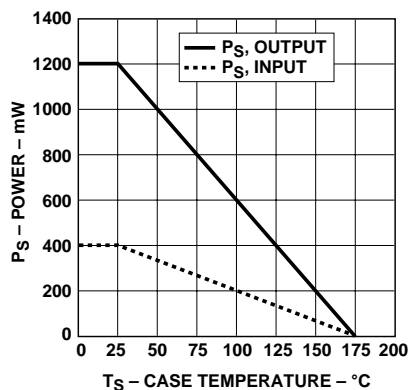

Figure 2. Dependence of safety limiting values on temperature.

Insulation and Safety Related Specifications

Parameter	Symbol	Value	Units	Conditions
Minimum External Air Gap (Clearance)	L(101)	8.3	mm	Measured from input terminals to output terminals, shortest distance through air.
Minimum External Tracking (Creepage)	L(102)	8.3	mm	Measured from input terminals to output terminals, shortest distance path along body.
Minimum Internal Plastic Gap (Internal Clearance)		0.5	mm	Through insulation distance conductor to conductor, usually the straight line distance thickness between the emitter and detector.
Tracking Resistance (Comparative Tracking Index)	CTI	>175	Volts	DIN IEC 112/VDE 0303 Part 1
Isolation Group		IIIa		Material Group (DIN VDE 0110, 1/89, Table 1)

Absolute Maximum Ratings

Parameter	Symbol	Min.	Max.	Units	Note	
Storage Temperature	T_s	-55	125	°C		
Operating Temperature	T_A	-40	100			
Output IC Junction Temperature	T_J		125		4	
Peak Output Current	$ I_{o(peak)} $		2.5	A	5	
Fault Output Current	I_{FAULT}		8.0	mA		
Positive Input Supply Voltage	V_{CC1}	-0.5	5.5	Volts		
Input Pin Voltages	V_{IN+} , V_{IN-} and V_{RESET}	-0.5	V_{CC1}			
Total Output Supply Voltage	$(V_{CC2} - V_{EE})$	-0.5	35			
Negative Output Supply Voltage	$(V_E - V_{EE})$	-0.5	15		6	
Positive Output Supply Voltage	$(V_{CC2} - V_E)$	-0.5	$35 - (V_E - V_{EE})$			
Gate Drive Output Voltage	$V_{o(peak)}$	-0.5	V_{CC2}			
Collector Voltage	V_C	$V_{EE} + 5 V$	V_{CC2}			
DESAT Voltage	V_{DESAT}	V_E	$V_E + 10$			
Output IC Power Dissipation	P_O		600		mW	4
Input IC Power Dissipation	P_I		150			
Solder Reflow Temperature Profile	See Package Outline Drawings section					

Recommended Operating Conditions

Parameter	Symbol	Min.	Max.	Units	Note
Operating Temperature	T_A	-40	+100	°C	
Input Supply Voltage	V_{CC1}	4.5	5.5	Volts	28
Total Output Supply Voltage	$(V_{CC2} - V_{EE})$	15	30		9
Negative Output Supply Voltage	$(V_E - V_{EE})$	0	15		6
Positive Output Supply Voltage	$(V_{CC2} - V_E)$	15	$30 - (V_E - V_{EE})$		
Collector Voltage	V_C	$V_{EE} + 6$	V_{CC2}		

Electrical Specifications (DC)

Unless otherwise noted, all typical values at $T_A = 25^\circ\text{C}$, $V_{CC1} = 5\text{ V}$, and $V_{CC2} - V_{EE} = 30\text{ V}$, $V_E - V_{EE} = 0\text{ V}$; all Minimum/Maximum specifications are at Recommended Operating Conditions.

Parameter	Symbol	Min.	Typ.	Max.	Units	Test Conditions	Fig.	Note
Logic Low Input Voltages	$V_{IN+L}, V_{IN-L}, V_{RESETL}$			0.8	V			
Logic High Input Voltages	$V_{IN+H}, V_{IN-H}, V_{RESETH}$	2.0						
Logic Low Input Currents	$I_{IN+L}, I_{IN-L}, I_{RESETL}$	-0.5	-0.4		mA	$V_{IN} = 0.4\text{ V}$		
$\overline{\text{FAULT}}$ Logic Low Output Current	$I_{\overline{\text{FAULTL}}}$	5.0	12			$V_{\overline{\text{FAULT}}} = 0.4\text{ V}$	30	
$\overline{\text{FAULT}}$ Logic High Output Current	$I_{\overline{\text{FAULTH}}}$	-40			μA	$V_{\overline{\text{FAULT}}} = V_{CC1}$	31	
High Level Output Current	I_{OH}	-0.5 -2.0	-1.5		A	$V_{OUT} = V_{CC2} - 4\text{ V}$ $V_{OUT} = V_{CC2} - 15\text{ V}$	3, 8, 32	7 5
Low Level Output Current	I_{OL}	0.5 2.0	2.3			$V_{OUT} = V_{EE} + 2.5\text{ V}$ $V_{OUT} = V_{EE} + 15\text{ V}$	4, 9, 33	7 5
Low Level Output Current During Fault Condition	I_{OLF}	90	160	230	mA	$V_{OUT} - V_{EE} = 14\text{ V}$	5, 34	8
High Level Output Voltage	V_{OH}	$V_C - 3.5$ $V_C - 2.9$	$V_C - 2.5$ $V_C - 2.0$	$V_C - 1.5$ $V_C - 1.2$ V_C	V	$I_{OUT} = -100\text{ mA}$ $I_{OUT} = -650\text{ }\mu\text{A}$ $I_{OUT} = 0$	6, 8, 35	9, 10, 11
Low Level Output Voltage	V_{OL}		0.17	0.5		$I_{OUT} = 100\text{ mA}$	7, 9, 36	26
High Level Input Supply Current	I_{CC1H}		17	22	mA	$V_{IN+} = V_{CC1} = 5.5\text{ V}, V_{IN-} = 0\text{ V}$	10, 37 38	
Low Level Input Supply Current	I_{CC1L}		6	11		$V_{IN+} = V_{IN-} = 0\text{ V}, V_{CC1} = 5.5\text{ V}$		
Output Supply Current	I_{CC2}		2.5	5		V_{OUT} open	11, 12, 39, 40	11
Low Level Collector Current	I_{CL}		0.3	1.0		$I_{OUT} = 0$	15, 59	27
High Level Collector Current	I_{CH}		0.3 1.8	1.3 3.0		$I_{OUT} = 0$ $I_{OUT} = -650\text{ }\mu\text{A}$	15, 58 15, 57	27
V_E Low Level Supply Current	I_{EL}	-0.7	-0.4	0			14, 61	
V_E High Level Supply Current	I_{EH}	-0.5	-0.14	0			14, 40	25
Blanking Capacitor Charging Current	I_{CHG}	-0.13 -0.18	-0.25	-0.33		$V_{DESAT} = 0 - 6\text{ V}$ $V_{DESAT} = 0 - 6\text{ V}, T_A = 25^\circ\text{C} - 100^\circ\text{C}$	13, 41	11, 12
Blanking Capacitor Discharge Current	I_{DSCHG}	10	50			$V_{DESAT} = 7\text{ V}$	42	
UVLO Threshold	V_{UVLO+} V_{UVLO-}	11.6	12.3 11.1	13.5 12.4	V	$V_{OUT} > 5\text{ V}$ $V_{OUT} < 5\text{ V}$	43	9, 11, 13 9, 11, 14
UVLO Hysteresis	$(V_{UVLO+} - V_{UVLO-})$	0.4	1.2					
DESAT Threshold	V_{DESAT}	6.5	7.0	7.5		$V_{CC2} - V_E > V_{UVLO-}$	16, 44	11

Switching Specifications (AC)

Unless otherwise noted, all typical values at $T_A = 25^\circ\text{C}$, $V_{CC1} = 5\text{ V}$, and $V_{CC2} - V_{EE} = 30\text{ V}$, $V_E - V_{EE} = 0\text{ V}$; all Minimum/Maximum specifications are at Recommended Operating Conditions.

Parameter	Symbol	Min.	Typ.	Max.	Units	Test Conditions	Fig.	Note			
V_{IN} to High Level Output Propagation Delay Time	t_{PLH}	0.10	0.30	0.50	μs	$R_g = 10\ \Omega$ $C_g = 10\ \text{nF}$, $f = 10\ \text{kHz}$, Duty Cycle = 50%	17,18,19, 20,21,22, 45,54,55	15			
V_{IN} to Low Level Output Propagation Delay Time	t_{PHL}	0.10	0.32	0.50							
Pulse Width Distortion	PWD	-0.30	0.02	0.30							16,17
Propagation Delay Difference Between Any Two Parts	$(t_{PHL} - t_{PLH})$ PDD	-0.35		0.35							17,18
10% to 90% Rise Time	t_r		0.1							45	
90% to 10% Fall Time	t_f		0.1								
DESAT Sense to 90% V_{OUT} Delay	$t_{DESAT(90\%)}$		0.3	0.5		$R_g = 10\ \Omega$, $C_g = 10\ \text{nF}$	23,56	19			
DESAT Sense to 10% V_{OUT} Delay	$t_{DESAT(10\%)}$		2.0	3.0		$V_{CC2} - V_{EE} = 30\text{ V}$	24,28, 46,56				
DESAT Sense to Low Level $\overline{\text{FAULT}}$ Signal Delay	$t_{DESAT(\overline{\text{FAULT}})}$		1.8	5			25,47, 56	20			
DESAT Sense to DESAT Low Propagation Delay	$t_{DESAT(\text{LOW})}$		0.25				56	21			
$\overline{\text{RESET}}$ to High Level $\overline{\text{FAULT}}$ Signal Delay	$t_{\overline{\text{RESET}}(\overline{\text{FAULT}})}$	3	7	20			26,27, 56	22			
$\overline{\text{RESET}}$ Signal Pulse Width	$PW_{\overline{\text{RESET}}}$	0.1									
UVLO to V_{OUT} High Delay	$t_{UVLO\ \text{ON}}$		4.0			$V_{CC2} = 1.0\ \text{ms}$ ramp	49	13			
UVLO to V_{OUT} Low Delay	$t_{UVLO\ \text{OFF}}$		6.0		14						
Output High Level Common Mode Transient Immunity	$ CM_H $	15	30		$\text{kV}/\mu\text{s}$	$T_A = 25^\circ\text{C}$, $V_{CM} = 1500\text{ V}$, $V_{CC2} = 30\text{ V}$	50,51, 52,53	23			
Output Low Level Common Mode Transient Immunity	$ CM_L $	15	30					$T_A = 25^\circ\text{C}$, $V_{CM} = 1500\text{ V}$, $V_{CC2} = 30\text{ V}$	24		

Notes:

1. In accordance with UL1577, each optocoupler is proof tested by applying an insulation test voltage ≥ 4500 Vrms for 1 second (leakage detection current limit, $I_{L0} \leq 5 \mu\text{A}$). This test is performed before the 100% production test for partial discharge (method b) shown in IEC/EN/DIN EN 60747-5-2 Insulation Characteristic Table, if applicable.
2. The Input-Output Momentary Withstand Voltage is a dielectric voltage rating that should not be interpreted as an input-output continuous voltage rating. For the continuous voltage rating refer to your equipment level safety specification or IEC/EN/DIN EN 60747-5-2 Insulation Characteristics Table.
3. Device considered a two terminal device: pins 1 - 8 shorted together and pins 9 - 16 shorted together.
4. In order to achieve the absolute maximum power dissipation specified, pins 4, 9, and 10 require ground plane connections and may require airflow. See the Thermal Model section in the application notes at the end of this data sheet for details on how to estimate junction temperature and power dissipation. In most cases the absolute maximum output IC junction temperature is the limiting factor. The actual power dissipation achievable will depend on the application environment (PCB Layout, air flow, part placement, etc.). See the Recommended PCB Layout section in the application notes for layout considerations. Output IC power dissipation is derated linearly at 10 mW/°C above 90°C. Input IC power dissipation does not require derating.
5. Maximum pulse width = 10 μs , maximum duty cycle = 0.2%. This value is intended to allow for component tolerances for designs with I_O peak minimum = 2.0 A. See Applications section for additional details on I_{OH} peak. Derate linearly from 3.0 A at +25°C to 2.5 A at +100°C. This compensates for increased I_{OPEAK} due to changes in V_{OL} over temperature.
6. This supply is optional. Required only when negative gate drive is implemented.
7. Maximum pulse width = 50 μs , maximum duty cycle = 0.5%.
8. See the Slow IGBT Gate Discharge During Fault Condition section in the applications notes at the end of this data sheet for further details.
9. 15 V is the recommended minimum operating positive supply voltage ($V_{CC2} - V_E$) to ensure adequate margin in excess of the maximum V_{UVLO+} threshold of 13.5 V. For High Level Output Voltage testing, V_{OH} is measured with a dc load current. When driving capacitive loads, V_{OH} will approach V_{CC} as I_{OH} approaches zero units.
10. Maximum pulse width = 1.0 ms, maximum duty cycle = 20%.
11. Once V_{OUT} of the HCPL-316J is allowed to go high ($V_{CC2} - V_E > V_{UVLO}$), the DESAT detection feature of the HCPL-316J will be the primary source of IGBT protection. UVLO is needed to ensure DESAT is functional. Once $V_{UVLO+} > 11.6$ V, DESAT will remain functional until $V_{UVLO-} < 12.4$ V. Thus, the DESAT detection and UVLO features of the HCPL-316J work in conjunction to ensure constant IGBT protection.
12. See the Blanking Time Control section in the applications notes at the end of this data sheet for further details.
13. This is the "increasing" (i.e. turn-on or "positive going" direction) of $V_{CC2} - V_E$.
14. This is the "decreasing" (i.e. turn-off or "negative going" direction) of $V_{CC2} - V_E$.
15. This load condition approximates the gate load of a 1200 V/75A IGBT.
16. Pulse Width Distortion (PWD) is defined as $|t_{PHL} - t_{PLH}|$ for any given unit.
17. As measured from V_{IN+} , V_{IN-} to V_{OUT} .
18. The difference between t_{PHL} and t_{PLH} between any two HCPL-316J parts under the same test conditions.
19. Supply Voltage Dependent.
20. This is the amount of time from when the DESAT threshold is exceeded, until the FAULT output goes low.
21. This is the amount of time the DESAT threshold must be exceeded before V_{OUT} begins to go low, and the FAULT output to go low.
22. This is the amount of time from when $\overline{\text{RESET}}$ is asserted low, until $\overline{\text{FAULT}}$ output goes high. The minimum specification of 3 μs is the guaranteed minimum FAULT signal pulse width when the HCPL-316J is configured for Auto-Reset. See the Auto-Reset section in the applications notes at the end of this data sheet for further details.
23. Common mode transient immunity in the high state is the maximum tolerable dV_{CM}/dt of the common mode pulse, V_{CM} , to assure that the output will remain in the high state (i.e., $V_O > 15$ V or $\overline{\text{FAULT}} > 2$ V). A 100 pF and a 3K Ω pull-up resistor is needed in fault detection mode.
24. Common mode transient immunity in the low state is the maximum tolerable dV_{CM}/dt of the common mode pulse, V_{CM} , to assure that the output will remain in a low state (i.e., $V_O < 1.0$ V or $\overline{\text{FAULT}} < 0.8$ V).
25. Does not include LED2 current during fault or blanking capacitor discharge current.
26. To clamp the output voltage at $V_{CC} - 3 V_{BE}$, a pull-down resistor between the output and V_{EE} is recommended to sink a static current of 650 μA while the output is high. See the Output Pull-Down Resistor section in the application notes at the end of this data sheet if an output pull-down resistor is not used.
27. The recommended output pull-down resistor between V_{OUT} and V_{EE} does not contribute any output current when $V_{OUT} = V_{EE}$.
28. In most applications V_{CC1} will be powered up first (before V_{CC2}) and powered down last (after V_{CC2}). This is desirable for maintaining control of the IGBT gate. In applications where V_{CC2} is powered up first, it is important to ensure that V_{in+} remains low until V_{CC1} reaches the proper operating voltage (minimum 4.5 V) to avoid any momentary instability at the output during V_{CC1} ramp-up or ramp-down.

Performance Plots

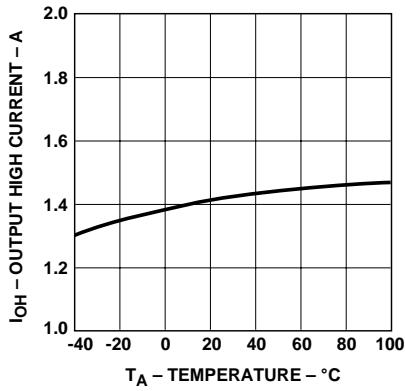

Figure 3. I_{OH} vs. temperature.

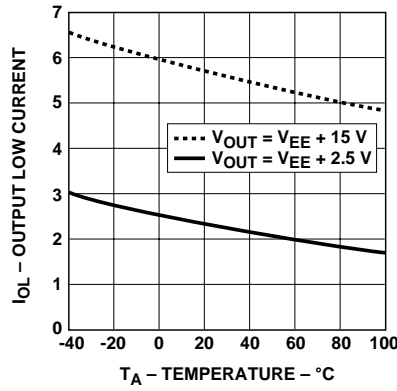

Figure 4. I_{OL} vs. temperature.

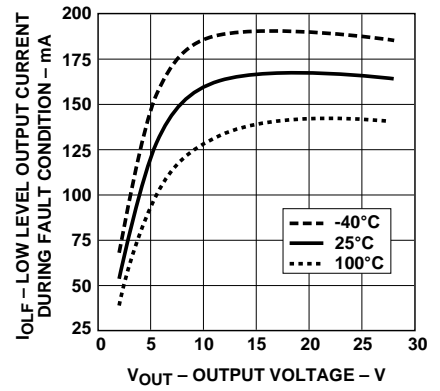

Figure 5. I_{OLF} vs. V_{OUT} .

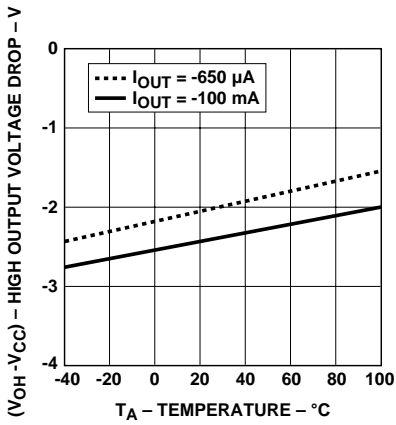

Figure 6. V_{OH} vs. temperature.

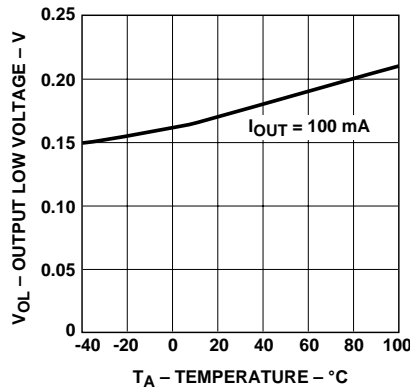

Figure 7. V_{OL} vs. temperature.

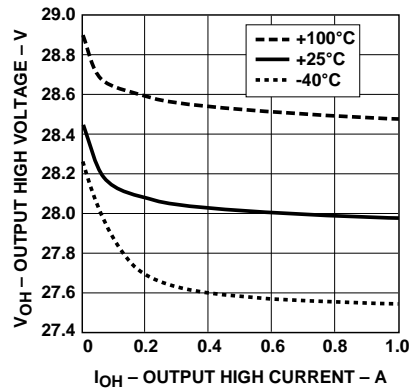

Figure 8. V_{OH} vs. I_{OH} .

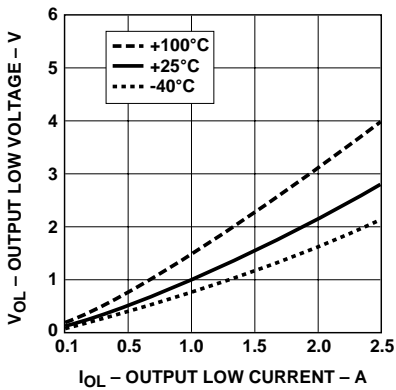

Figure 9. V_{OL} vs. I_{OL} .

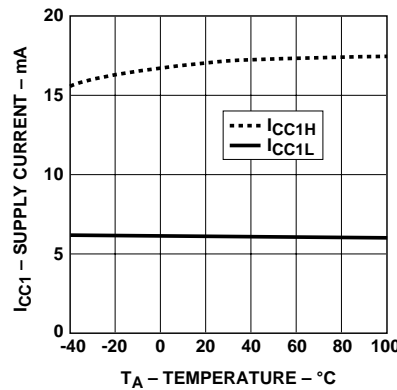

Figure 10. I_{CC1} vs. temperature.

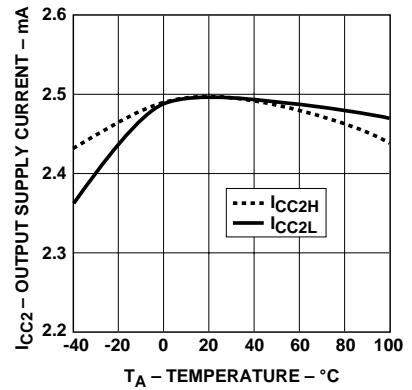

Figure 11. I_{CC2} vs. temperature.

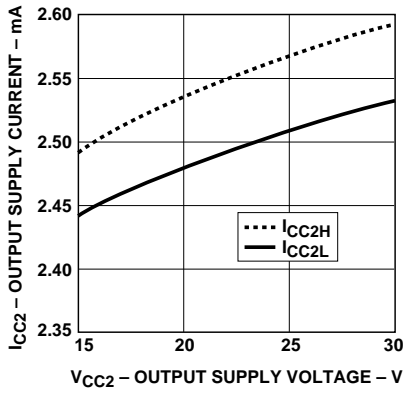

Figure 12. I_{CC2} vs. V_{CC2}.

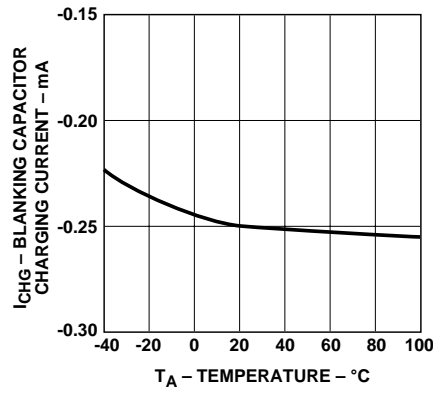

Figure 13. I_{CHG} vs. temperature.

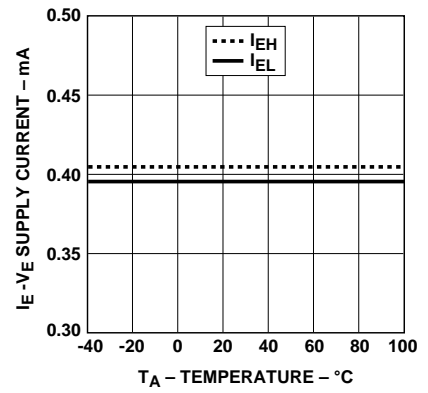

Figure 14. I_E vs. temperature.

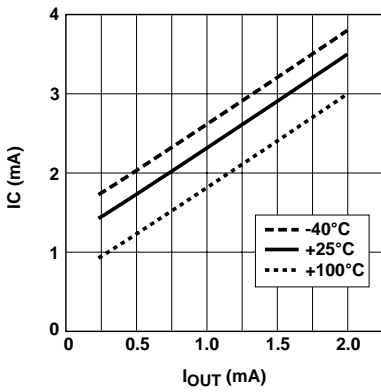

Figure 15. I_C vs. I_{OUT}.

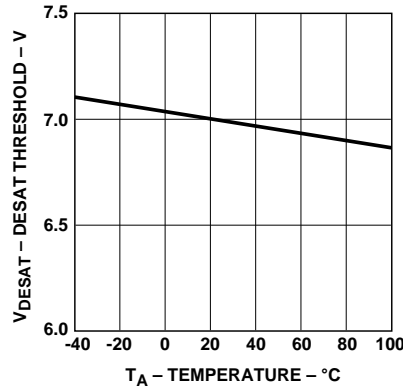

Figure 16. DESAT threshold vs. temperature.

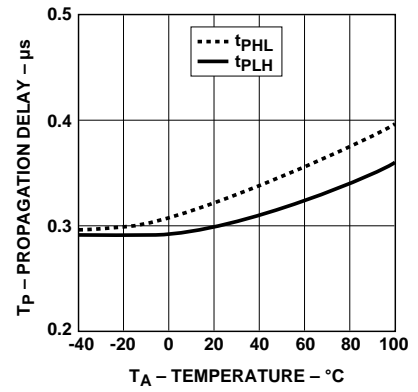

Figure 17. Propagation delay vs. temperature.

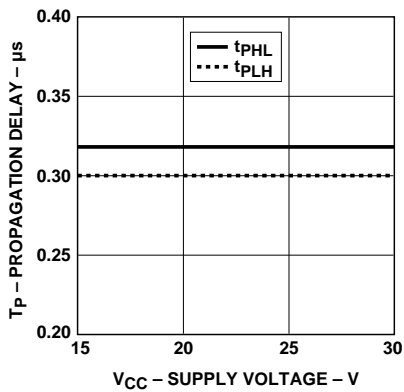

Figure 18. Propagation delay vs. supply voltage.

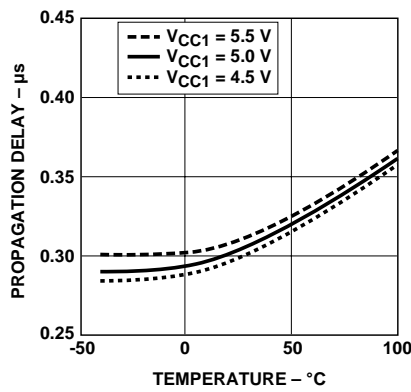

Figure 19. V_{IN} to high propagation delay vs. temperature.

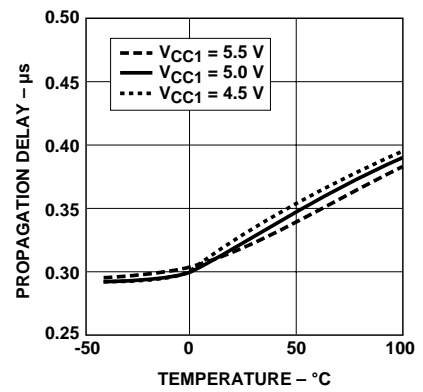

Figure 20. V_{IN} to low propagation delay vs. temperature.

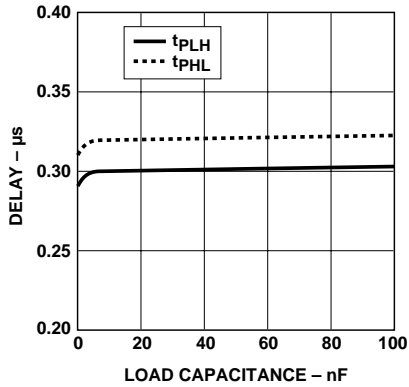

Figure 21. Propagation delay vs. load capacitance.

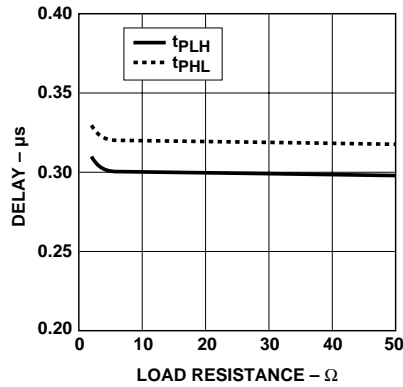

Figure 22. Propagation delay vs. load resistance.

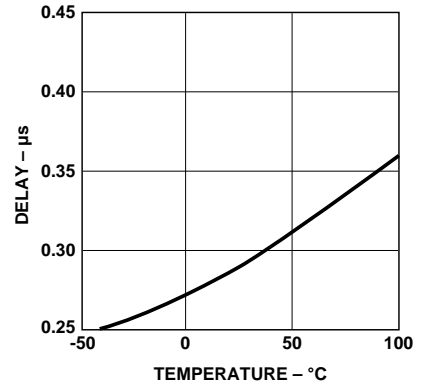

Figure 23. DESAT sense to 90% V_{out} delay vs. temperature.

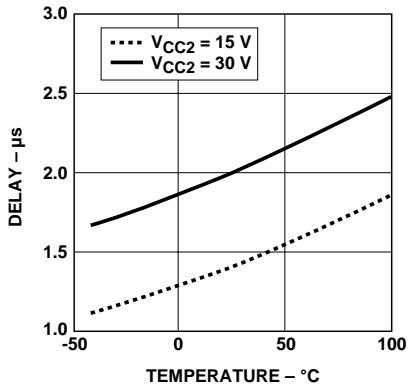

Figure 24. DESAT sense to 10% V_{out} delay vs. temperature.

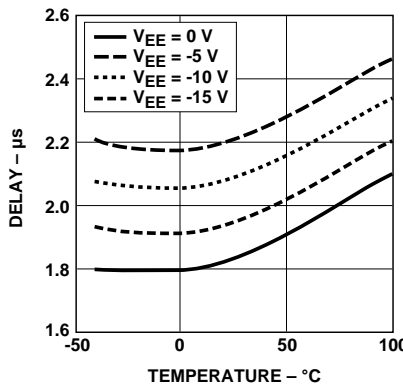

Figure 25. DESAT sense to low level fault signal delay vs. temperature.

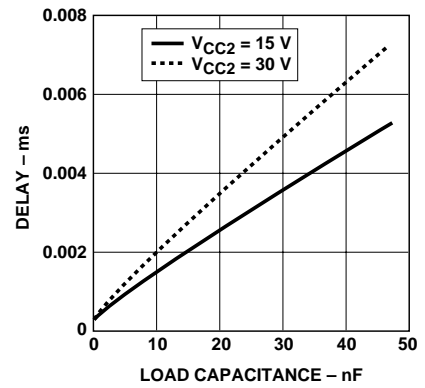

Figure 26. DESAT sense to 10% V_{out} delay vs. load capacitance.

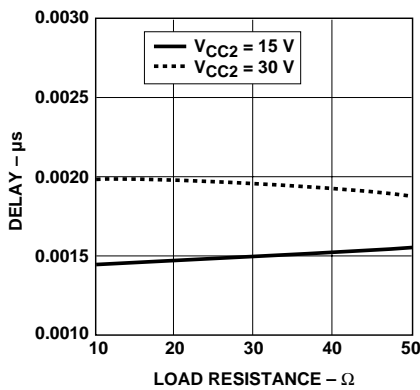

Figure 27. DESAT sense to 10% V_{out} delay vs. load resistance.

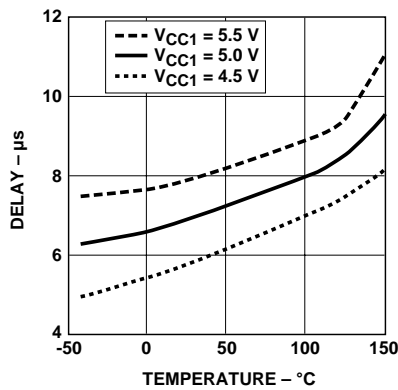

Figure 28. RESET to high level fault signal delay vs. temperature.

Test Circuit Diagrams

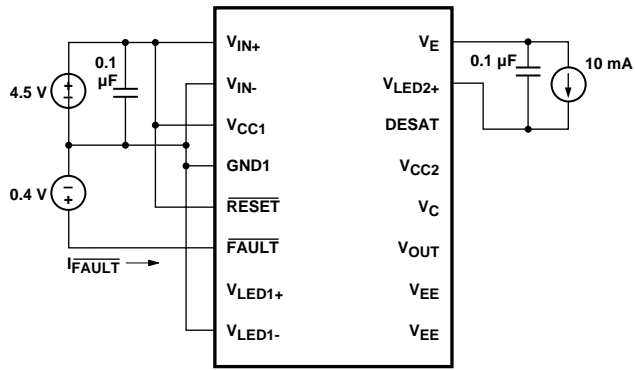

Figure 30. $I_{\overline{\text{FAULTL}}}$ test circuit.

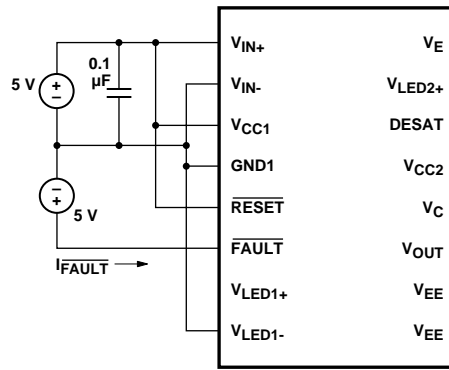

Figure 31. $I_{\overline{\text{FAULTH}}}$ test circuit.

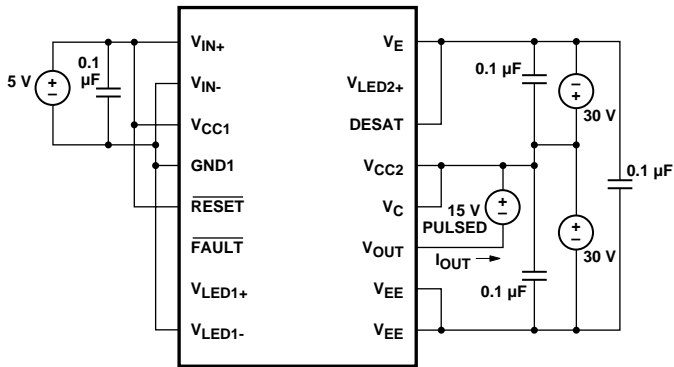

Figure 32. I_{OH} pulsed test circuit.

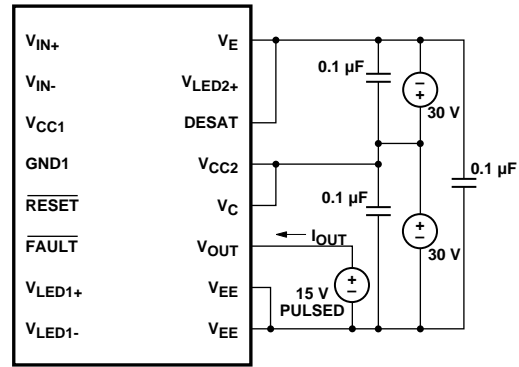

Figure 33. I_{OL} pulsed test circuit.

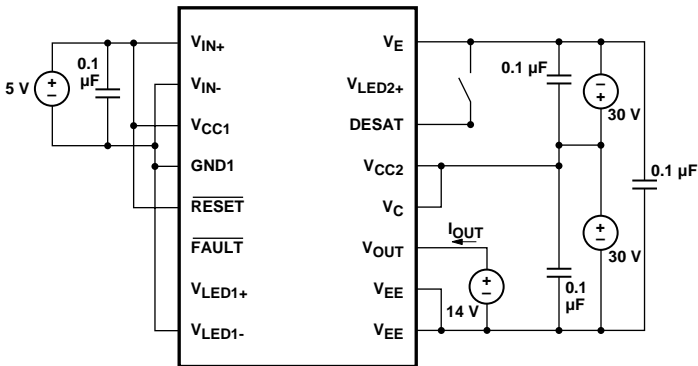

Figure 34. I_{OLF} test circuit.

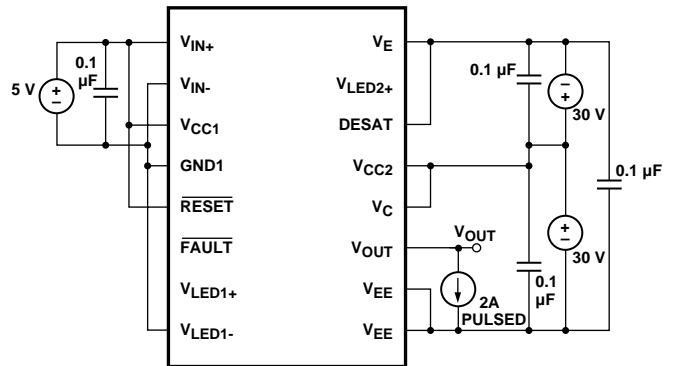

Figure 35. V_{OH} pulsed test circuit.

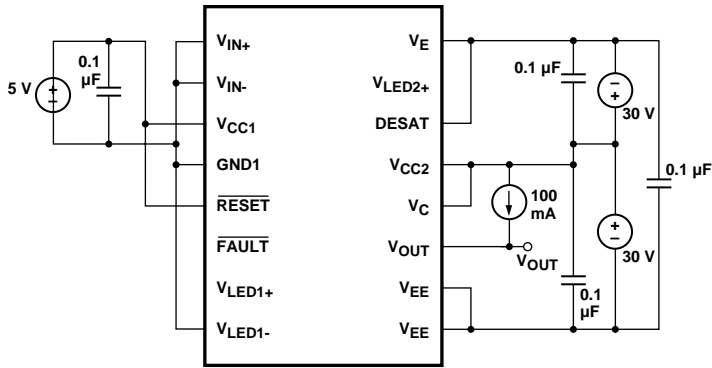

Figure 36. V_{OL} test circuit.

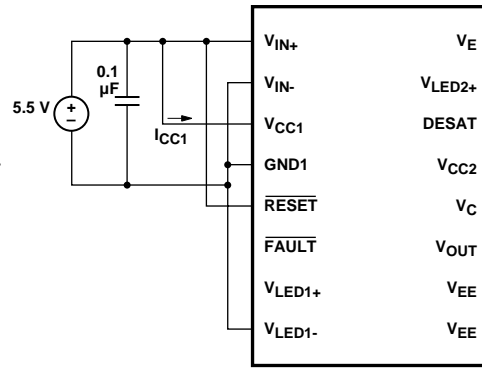

Figure 37. I_{CC1H} test circuit.

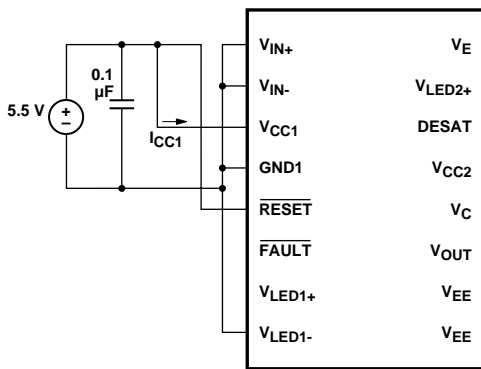

Figure 38. I_{CC1L} test circuit.

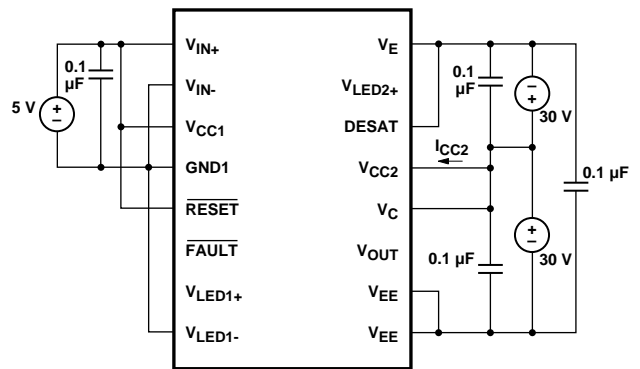

Figure 39. I_{CC2H} test circuit.

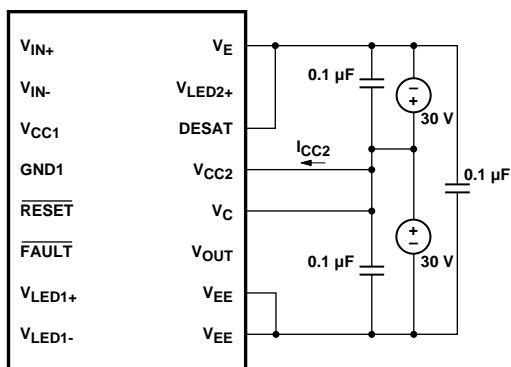

Figure 40. I_{CC2L} test circuit.

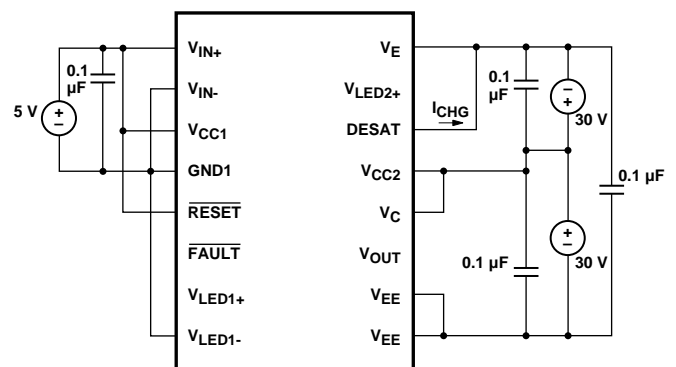

Figure 41. I_{CHG} pulsed test circuit.

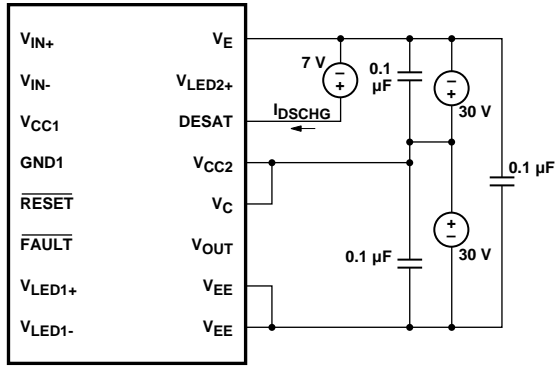

Figure 42. I_{DSCHG} test circuit.

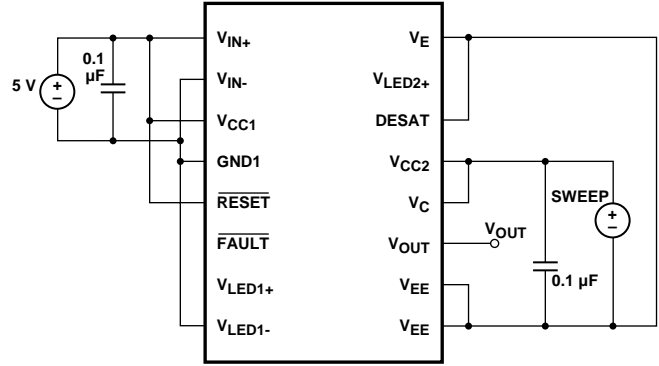

Figure 43. UVLO threshold test circuit.

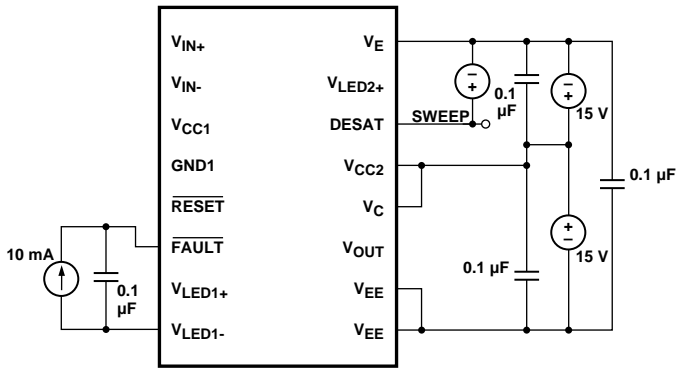

Figure 44. DESAT threshold test circuit.

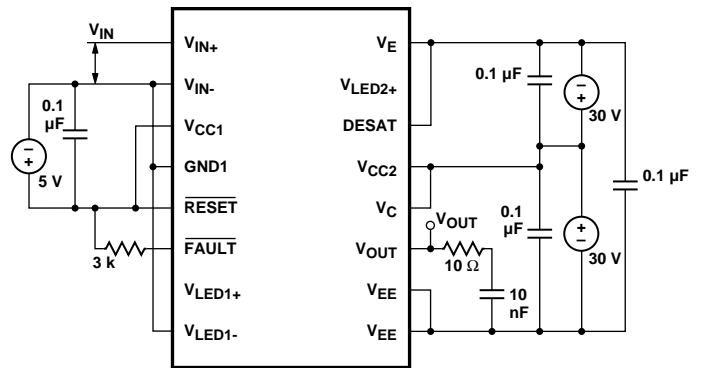

Figure 45. t_{PLH} , t_{PHL} , t_r , t_f test circuit.

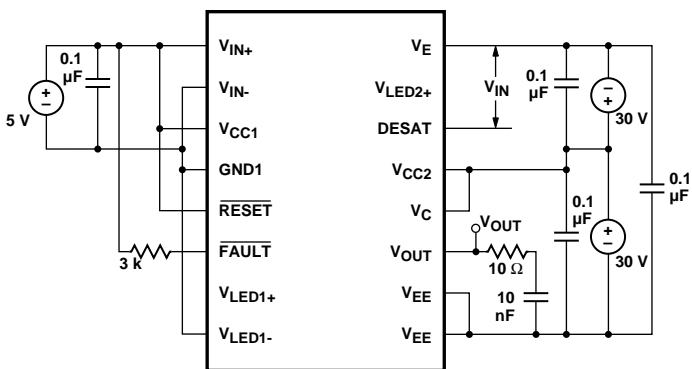

Figure 46. $t_{DESAT(10\%)}$ test circuit.

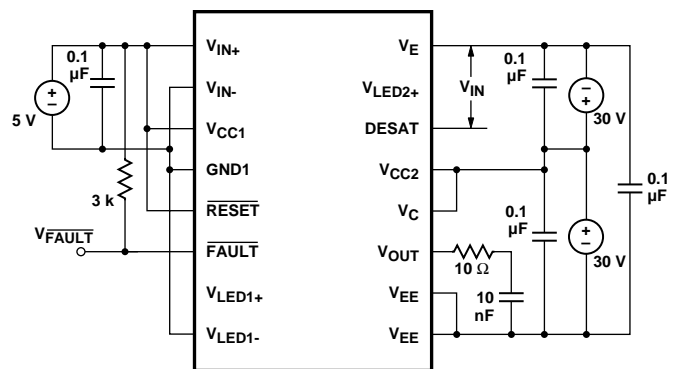

Figure 47. $t_{DESAT(\overline{FAULT})}$ test circuit.

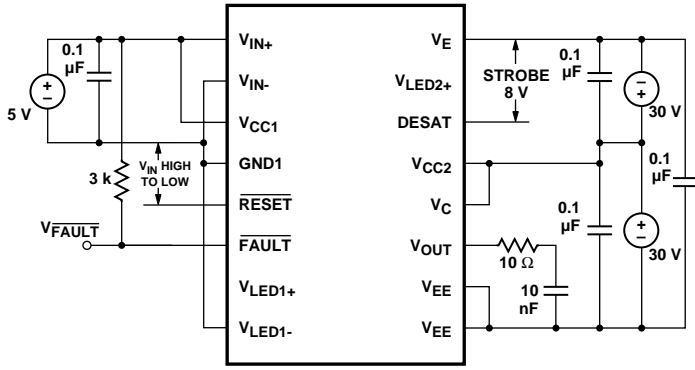

Figure 48. $t_{\text{RESET(FAULT)}}$ test circuit.

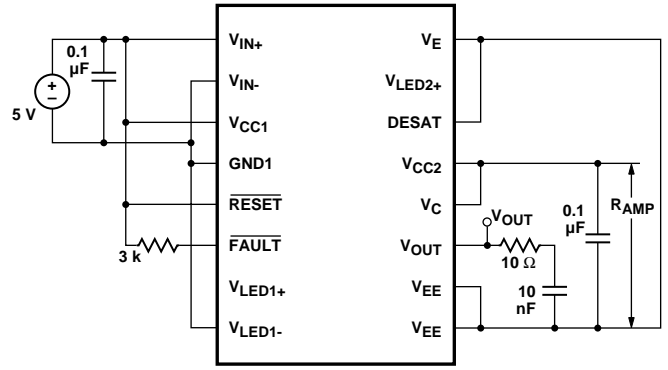

Figure 49. UVLO delay test circuit.

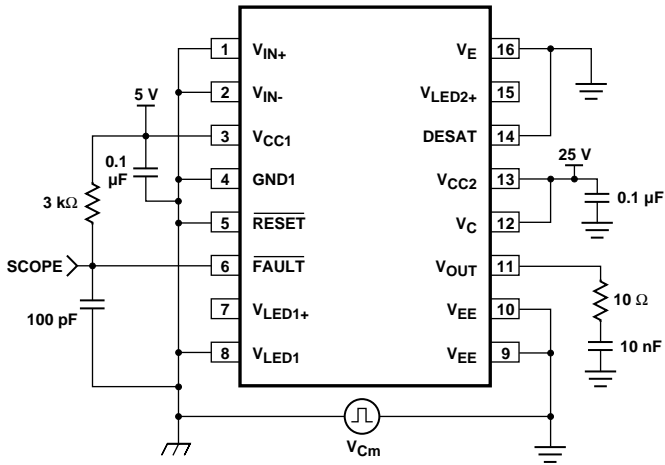

Figure 50. CMR test circuit, LED2 off.

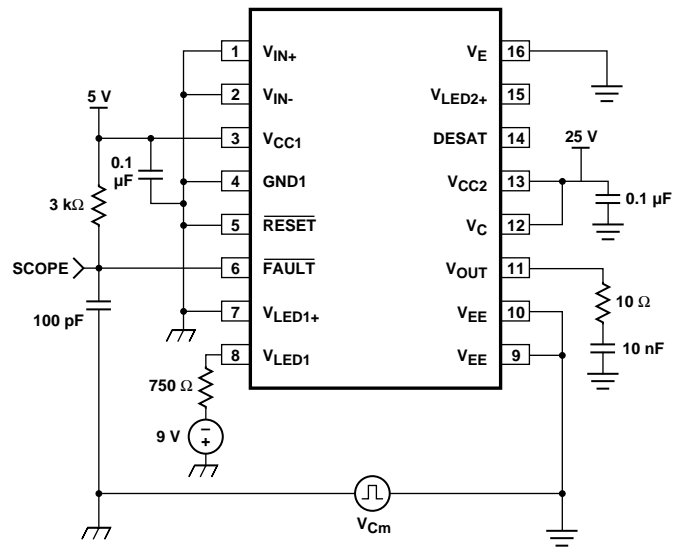

Figure 51. CMR test circuit, LED2 on.

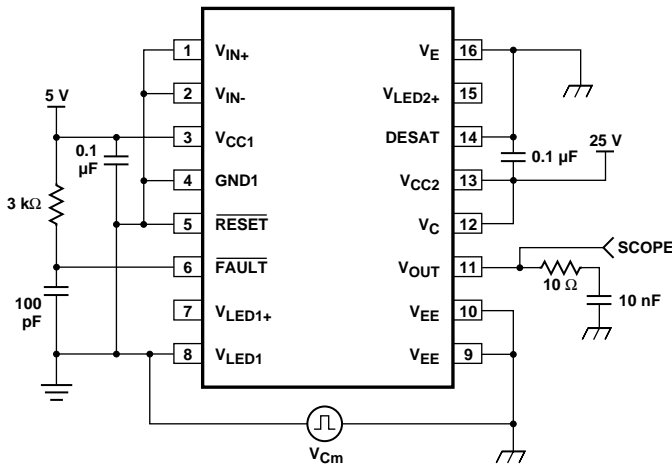

Figure 52. CMR test circuit, LED1 off.

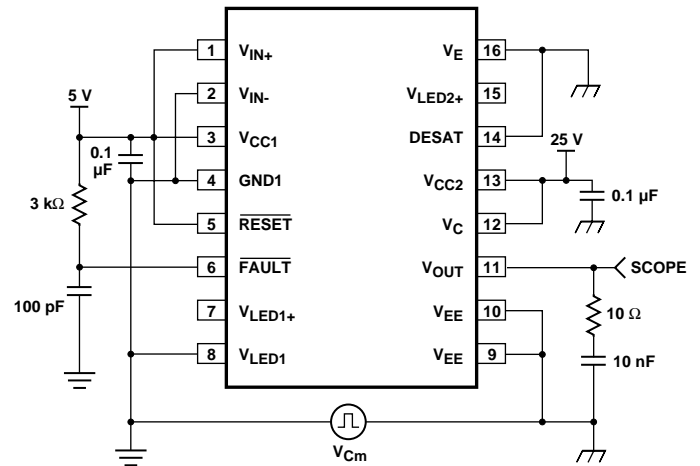

Figure 53. CMR test circuit, LED1 on.

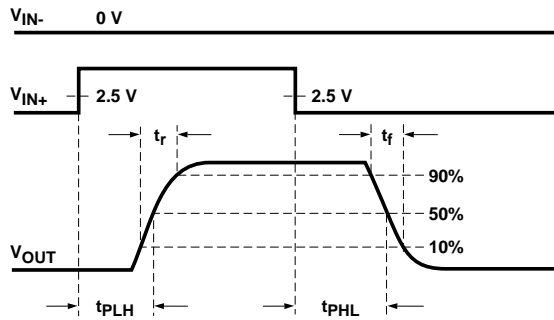

Figure 54. V_{OUT} propagation delay waveforms, noninverting configuration.

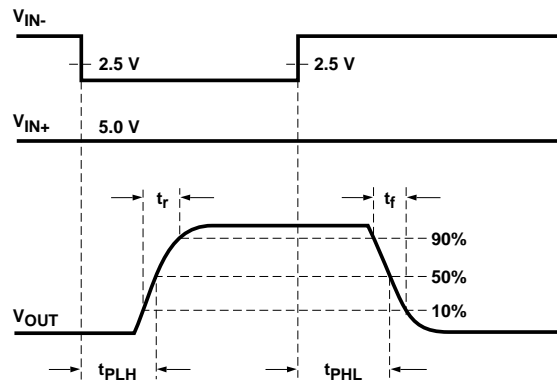

Figure 55. V_{OUT} propagation delay waveforms, inverting configuration.

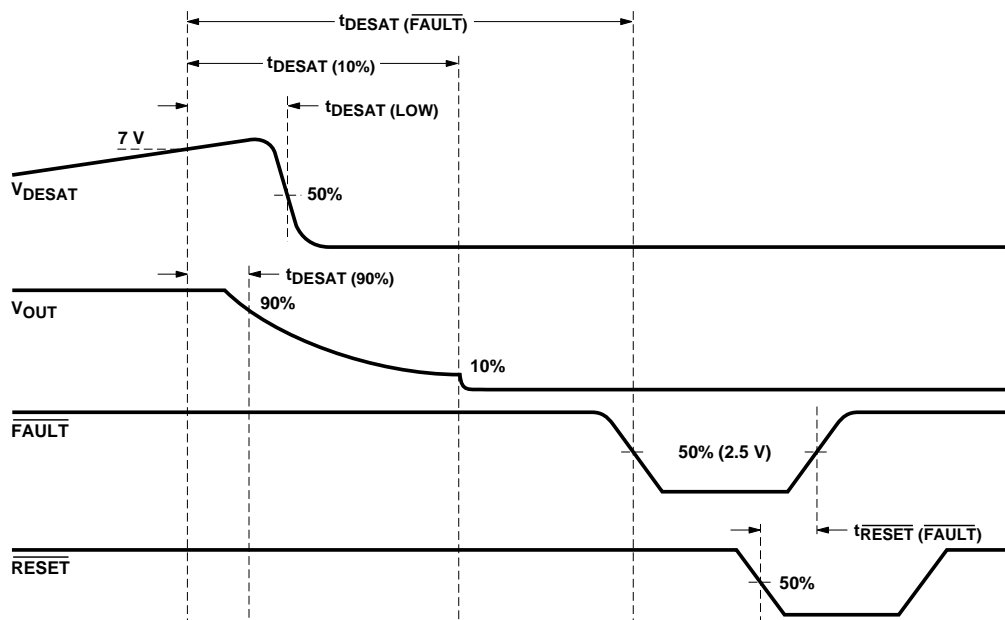

Figure 56. Desat, V_{OUT} , fault, reset delay waveforms.

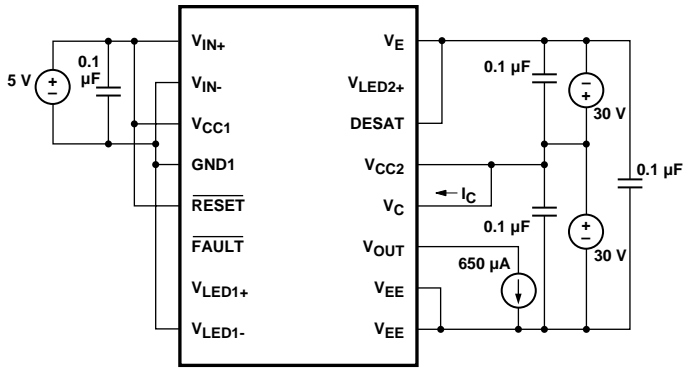

Figure 57. I_{CH} test circuit.

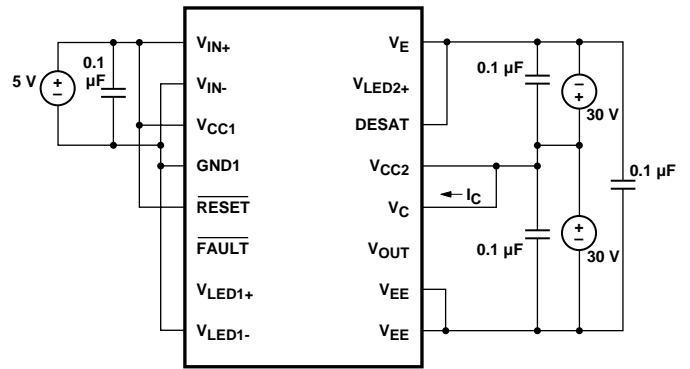

Figure 58. I_{CH} test circuit.

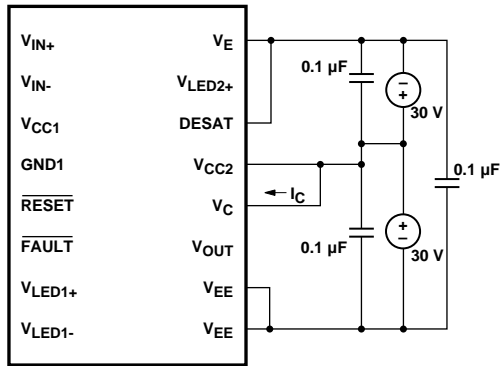

Figure 59. I_{CL} test circuit.

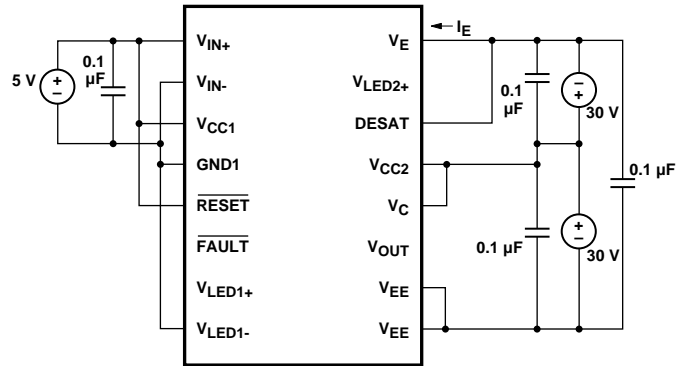

Figure 60. I_{EH} test circuit.

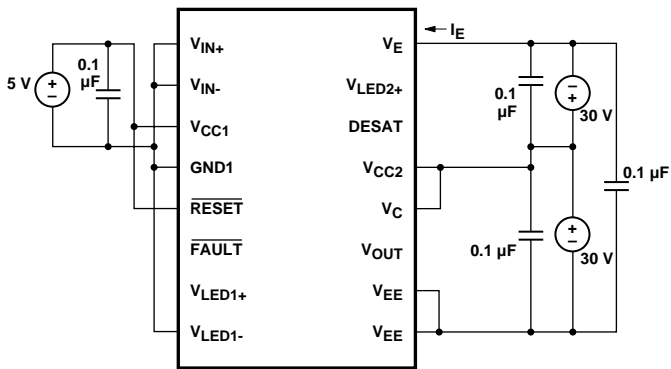

Figure 61. I_{EL} test circuit.

Typical Application/Operation Introduction to Fault Detection and Protection

The power stage of a typical three phase inverter is susceptible to several types of failures, most of which are potentially destructive to the power IGBTs. These failure modes can be grouped into four basic categories: phase and/or rail supply short circuits due to user misconnect or bad wiring, control signal failures due to noise or computational errors, overload conditions induced by the load, and component failures in the gate drive circuitry. Under any of these fault conditions, the current through the IGBTs can increase rapidly, causing excessive power dissipation and heating. The IGBTs become damaged when the current load approaches the saturation current of the device, and the collector to emitter voltage rises above the saturation voltage level. The drastically increased power dissipation very quickly overheats the power device and destroys it. To prevent damage to the drive, fault protection must be implemented to reduce or turn-off the overcurrents during a fault condition.

A circuit providing fast local fault detection and shutdown is an ideal solution, but the number of required components, board space consumed, cost, and complexity have until now limited its use to high performance drives. The features which this circuit must have are high speed, low cost, low resolution, low power dissipation, and small size.

Applications InformationThe HCPL-316J satisfies these criteria by combining a high speed, high output current driver, high voltage optical isolation between the input and output, local IGBT desaturation detection and shut down, and an optically isolated fault status feedback signal into a single 16-pin surface mount package.

The fault detection method, which is adopted in the HCPL-316J, is to monitor the saturation (collector) voltage of the IGBT and to trigger a local fault shutdown sequence if the collector voltage exceeds a predetermined threshold. A small gate discharge device slowly reduces the high short circuit IGBT current to prevent damaging voltage spikes. Before the dissipated energy can reach destructive levels, the IGBT is shut off. During the off state of the IGBT, the fault detect circuitry is simply disabled to prevent false 'fault' signals.

The alternative protection scheme of measuring IGBT current to prevent desaturation is effective if the short circuit capability of the power device is known, but this method will fail if the gate drive voltage decreases enough to only partially turn on the IGBT. By directly measuring the collector voltage, the HCPL-316J limits the power dissipation in the IGBT even with insufficient gate drive voltage. Another more subtle advantage of the desaturation detection method is that power dissipation in the IGBT is monitored, while the current sense method relies on a

preset current threshold to predict the safe limit of operation. Therefore, an overly-conservative overcurrent threshold is not needed to protect the IGBT.

Recommended Application Circuit

The HCPL-316J has both inverting and non-inverting gate control inputs, an active low reset input, and an open collector fault output suitable for wired 'OR' applications. The recommended application circuit shown in Figure 62 illustrates a typical gate drive implementation using the HCPL-316J.

The four supply bypass capacitors (0.1 μ F) provide the large transient currents necessary during a switching transition. Because of the transient nature of the charging currents, a low current (5 mA) power supply suffices. The desat diode and 100 pF capacitor are the necessary external components for the fault detection circuitry. The gate resistor (10 Ω) serves to limit gate charge current and indirectly control the IGBT collector voltage rise and fall times. The open collector fault output has a passive 3.3 k Ω pull-up resistor and a 330 pF filtering capacitor. A 47 k Ω pulldown resistor on V_{OUT} provides a more predictable high level output voltage (V_{OH}). In this application, the IGBT gate driver will shut down when a fault is detected and will not resume switching until the microcontroller applies a reset signal.

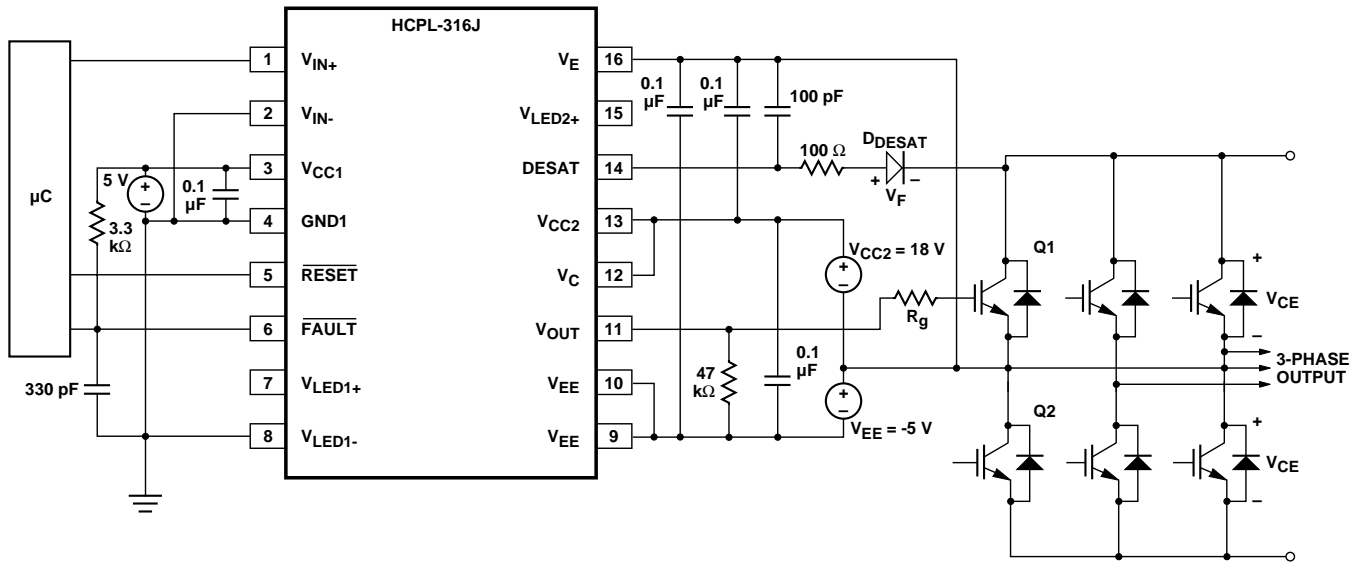

Figure 62. Recommended application circuit.

Description of Operation/Timing

Figure 63 below illustrates input and output waveforms under the conditions of normal operation, a desat fault condition, and normal reset behavior.

Normal Operation

During normal operation, V_{OUT} of the HCPL-316J is controlled by either V_{IN+} or V_{IN-} , with the IGBT collector-to-emitter voltage being monitored through D_{DESAT} . The \overline{FAULT} output is

high and the \overline{RESET} input should be held high. See Figure 63.

Fault Condition

When the voltage on the DESAT pin exceeds 7 V while the IGBT is on, V_{OUT} is slowly brought low in order to “softly” turn-off the IGBT and prevent large di/dt induced voltages. Also activated is an internal feedback channel which brings the \overline{FAULT} output low for the purpose of notifying

the micro-controller of the fault condition. See Figure 63.

Reset

The \overline{FAULT} output remains low until \overline{RESET} is brought low. See Figure 63. While asserting the \overline{RESET} pin (LOW), the input pins must be asserted for an output low state (V_{IN+} is LOW or V_{IN-} is HIGH). This may be accomplished either by software control (i.e. of the microcontroller) or hardware control (see Figures 73 and 74).

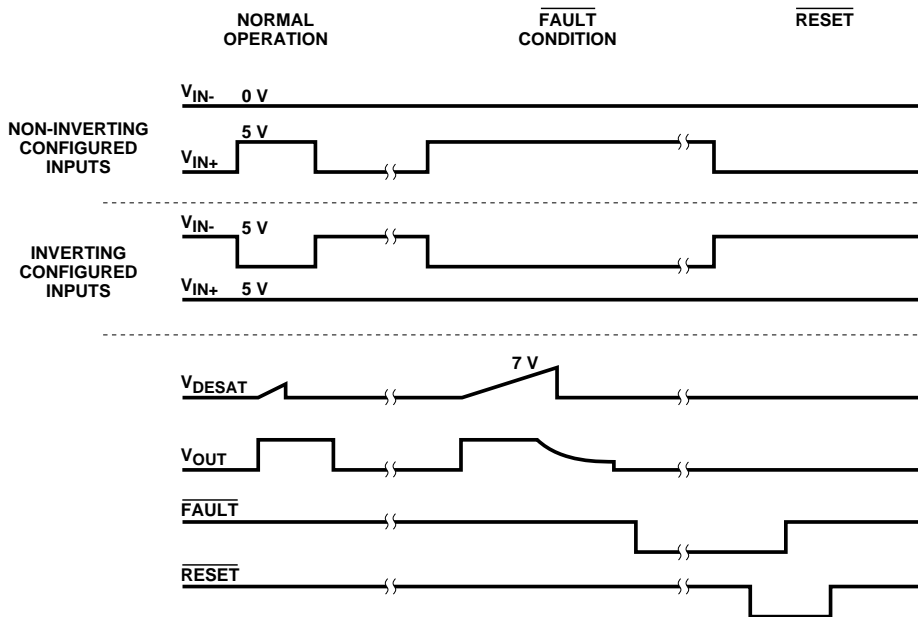

Figure 63. Timing diagram.

Slow IGBT Gate Discharge During Fault Condition

When a desaturation fault is detected, a weak pull-down device in the HCPL-316J output drive stage will turn on to 'softly' turn off the IGBT. This device slowly discharges the IGBT gate to prevent fast changes in drain current that could cause damaging voltage spikes due to lead and wire inductance. During the slow turn off, the large output pull-down device remains off until the output voltage falls below $V_{EE} + 2$ Volts, at which time the large pull down device clamps the IGBT gate to V_{EE} .

DESAT Fault Detection Blanking Time

The DESAT fault detection circuitry must remain disabled for a short time period following the turn-on of the IGBT to allow the collector voltage to fall below the DESAT threshold. This time period, called the DESAT blanking time, is controlled by the internal DESAT charge current, the DESAT voltage threshold, and the external DESAT capacitor. The nominal blanking time is calculated in terms of external capacitance (C_{BLANK}), \overline{FAULT} threshold

voltage (V_{DESAT}), and DESAT charge current (I_{CHG}) as $t_{BLANK} = C_{BLANK} \times V_{DESAT} / I_{CHG}$. The nominal blanking time with the recommended 100 pF capacitor is $100 \text{ pF} \times 7 \text{ V} / 250 \text{ } \mu\text{A} = 2.8 \text{ } \mu\text{sec}$. The capacitance value can be scaled slightly to adjust the blanking time, though a value smaller than 100 pF is not recommended. This nominal blanking time also represents the longest time it will take for the HCPL-316J to respond to a DESAT fault condition. If the IGBT is turned on while the collector and emitter are shorted to the supply rails (switching into a short), the soft shut-down sequence will begin after approximately 3 μsec . If the IGBT collector and emitter are shorted to the supply rails *after the IGBT is already on*, the response time will be much quicker due to the parasitic parallel capacitance of the DESAT diode. The recommended 100 pF capacitor should provide adequate blanking as well as fault response times for most applications.

Under Voltage Lockout

The HCPL-316J Under Voltage Lockout (UVLO) feature is designed to prevent the

application of insufficient gate voltage to the IGBT by forcing the HCPL-316J output low during power-up. IGBTs typically require gate voltages of 15 V to achieve their rated $V_{CE(ON)}$ voltage. At gate voltages below 13 V typically, their on-voltage increases dramatically, especially at higher currents. At very low gate voltages (below 10 V), the IGBT may operate in the linear region and quickly overheat. The UVLO function causes the output to be clamped whenever insufficient operating supply (V_{CC2}) is applied. Once V_{CC2} exceeds V_{UVLO+} (the positive-going UVLO threshold), the UVLO clamp is released to allow the device output to turn on in response to input signals. As V_{CC2} is increased from 0 V (at some level *below* V_{UVLO+}), first the DESAT protection circuitry becomes active. As V_{CC2} is further increased (above V_{UVLO+}), the UVLO clamp is released. Before the time the UVLO clamp is released, the DESAT protection is already active. Therefore, the UVLO and DESAT FAULT DETECTION features work together to provide seamless protection regardless of supply voltage (V_{CC2}).

Behavioral Circuit Schematic

The functional behavior of the HCPL-316J is represented by the logic diagram in Figure 64 which fully describes the interaction and sequence of internal and external signals in the HCPL-316J.

Input IC

In the normal switching mode, no output fault has been detected, and the low state of the fault latch allows the input signals to control the signal LED. The fault output is in the open-collector state, and the state of the Reset pin does not affect the control of the IGBT gate. When a fault is detected, the FAULT output and signal

input are both latched. The fault output changes to an active low state, and the signal LED is forced off (output LOW). The latched condition will persist until the Reset pin is pulled low.

Output IC

Three internal signals control the state of the driver output: the state of the signal LED, as well as the UVLO and Fault signals. If no fault on the IGBT collector is detected, and the supply voltage is above the UVLO threshold, the LED signal will control the driver output state. The driver stage logic includes an interlock to ensure that the pull-up and pull-down devices in the output stage are

never on at the same time. If an undervoltage condition is detected, the output will be actively pulled low by the 50x DMOS device, regardless of the LED state. If an IGBT desaturation fault is detected while the signal LED is on, the Fault signal will latch in the high state. The triple darlington AND the 50x DMOS device are disabled, and a smaller 1x DMOS pull-down device is activated to slowly discharge the IGBT gate. When the output drops below two volts, the 50x DMOS device again turns on, clamping the IGBT gate firmly to Vee. The Fault signal remains latched in the high state until the signal LED turns off.

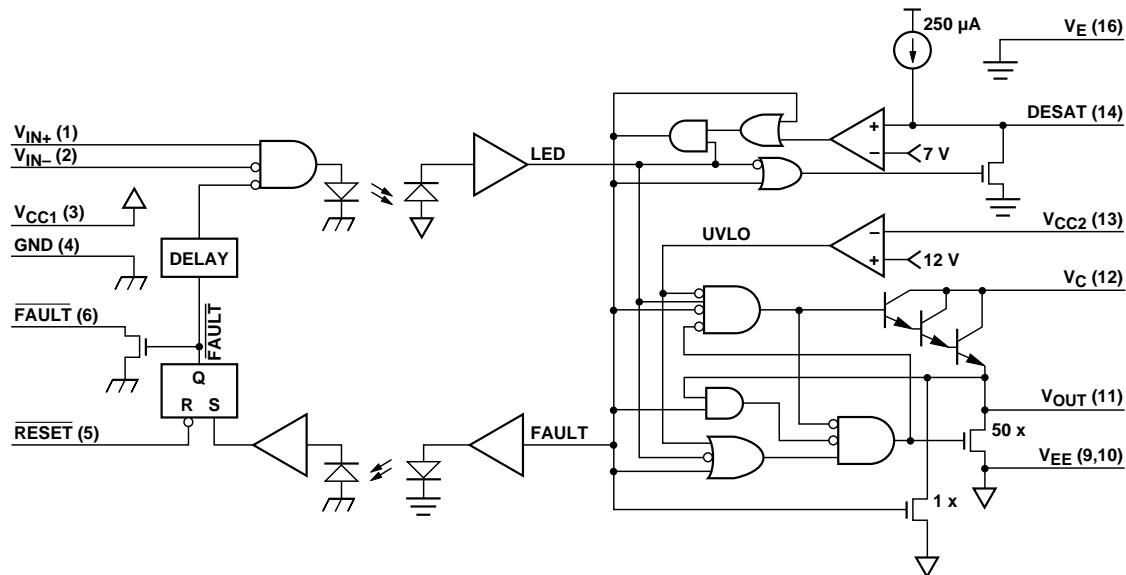

Figure 64. Behavioral circuit schematic.

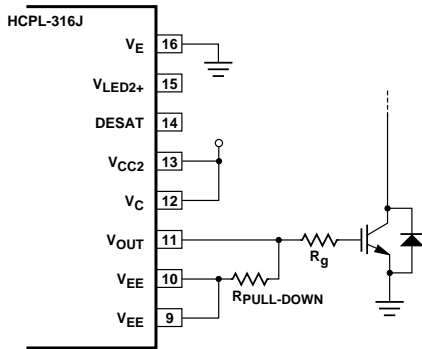

Figure 65. Output pull-down resistor.

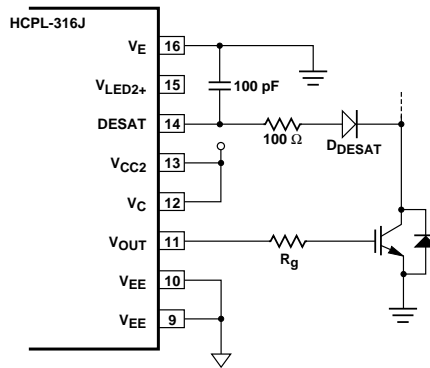

Figure 66. DESAT pin protection.

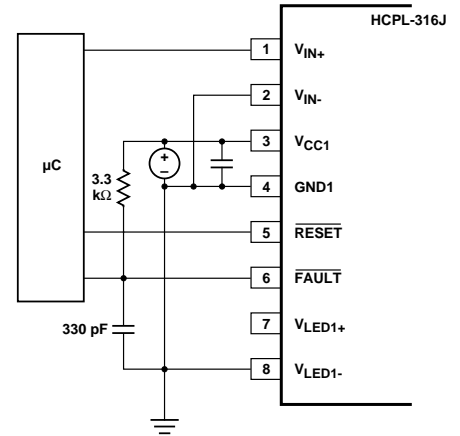

Figure 67. FAULT pin CMR protection.

Other Recommended Components

The application circuit in Figure 62 includes an output pull-down resistor, a DESAT pin protection resistor, a FAULT pin capacitor (330 pF), and a FAULT pin pull-up resistor.

Output Pull-Down Resistor

During the output high transition, the output voltage rapidly rises to within 3 diode drops of V_{CC2} . If the output current then drops to zero due to a capacitive load, the output voltage will slowly rise from roughly $V_{CC2}-3(V_{BE})$ to V_{CC2} within a period of several microseconds. To limit the output voltage to $V_{CC2}-3(V_{BE})$, a pull-down resistor between the output and V_{EE} is recommended to sink a static current of several 650 μA while the output is high. Pull-down resistor values are dependent on the amount of positive supply and can be adjusted according to the formula, $R_{pull-down} = [V_{CC2}-3 * (V_{BE})] / 650 \mu A$.

DESAT Pin Protection

The freewheeling of flyback diodes connected across the IGBTs can have large instantaneous forward voltage transients which greatly exceed the nominal forward voltage of the diode. This may result in a large negative voltage spike on the DESAT pin which will draw substantial current out of the IC if protection is not used. To limit this current to levels that will not damage the IC, a 100 ohm resistor should be inserted in series with the DESAT diode. The added resistance will not alter the DESAT threshold or the DESAT blanking time.

Capacitor on FAULT Pin for High CMR

Rapid common mode transients can affect the fault pin voltage while the fault output is in the high state. A 330 pF capacitor (Fig. 66) should be connected between the fault pin and ground to achieve adequate CMOS noise margins at the specified CMR value of 15 kV/ μs .

The added capacitance does not increase the fault output delay when a desaturation condition is detected.

Pull-up Resistor on FAULT Pin

The FAULT pin is an open-collector output and therefore requires a pull-up resistor to provide a high-level signal.

Driving with Standard CMOS/TTL for High CMR

Capacitive coupling from the isolated high voltage circuitry to the input referred circuitry is the primary CMR limitation. This coupling must be accounted for to achieve high CMR performance. The input pins V_{IN+} and V_{IN-} must have active drive signals to prevent unwanted switching of the output under extreme common mode transient conditions. Input drive circuits that use pull-up or pull-down resistors, such as open collector configurations, should be avoided. Standard CMOS or TTL drive circuits are recommended.

User-Configuration of the HCPL-316J Input Side

The V_{IN+} , V_{IN-} , \overline{FAULT} and \overline{RESET} input pins make a wide variety of gate control and fault configurations possible, depending on the motor drive requirements. The HCPL-316J has both inverting and non-inverting gate control inputs, an open collector fault output suitable for wired 'OR' applications and an active low reset input.

Driving Input of HCPL-316J in Non-Inverting/Inverting Mode

The Gate Drive Voltage Output of the HCPL-316J can be configured as inverting or non-inverting using the V_{IN-} and V_{IN+} inputs. As shown in Figure 68, when a non-inverting

configuration is desired, V_{IN-} is held low by connecting it to GND1 and V_{IN+} is toggled. As shown in Figure 69, when an inverting configuration is desired, V_{IN+} is held high by connecting it to V_{CC1} and V_{IN-} is toggled.

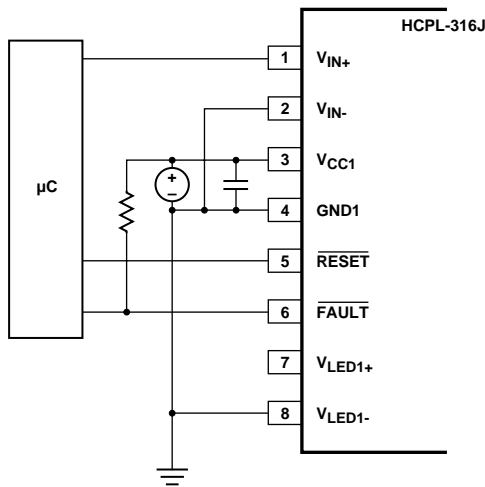

Figure 68. Typical input configuration, noninverting.

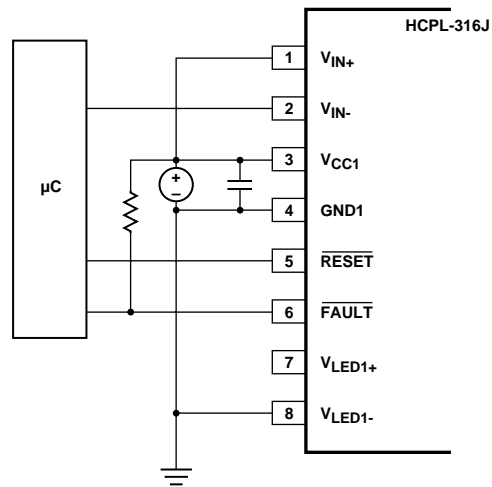

Figure 69. Typical Input Configuration, Inverting.

Local Shutdown, Local Reset

As shown in Figure 70, the fault output of each HCPL-316J gate driver is polled separately, and the individual reset lines are asserted low independently to reset the motor controller after a fault condition.

Global-Shutdown, Global Reset

As shown in Figure 71, when configured for inverting operation, the HCPL-316J can be configured to shutdown automatically in the event of a fault condition by tying the $\overline{\text{FAULT}}$ output to $V_{\text{IN}+}$. For high reliability drives, the open collector $\overline{\text{FAULT}}$ outputs of each HCPL-316J can be wire 'OR'ed together on a common fault bus, forming a single fault bus for interfacing directly to the microcontroller. When any of the six gate drivers detects a fault, the fault output signal will disable all six HCPL-316J gate drivers simultaneously and thereby provide protection against further catastrophic failures.

Auto-Reset

As shown in Figure 72, when the inverting $V_{\text{IN}-}$ input is connected to ground (non-inverting configuration), the HCPL-316J can be configured to reset automatically by connecting $\overline{\text{RESET}}$ to $V_{\text{IN}+}$. In this case, the gate control signal is applied to the non-inverting input as well as the reset input to reset the fault latch every switching cycle. During normal operation of the IGBT, asserting the reset input low has no effect. Following a fault condition, the gate driver remains in the latched fault state until the gate control signal changes to the 'gate low' state and resets the fault latch. If the gate control signal is a

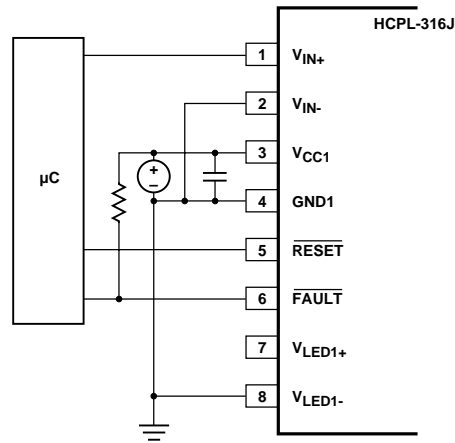

Figure 70. Local shutdown, local reset configuration.

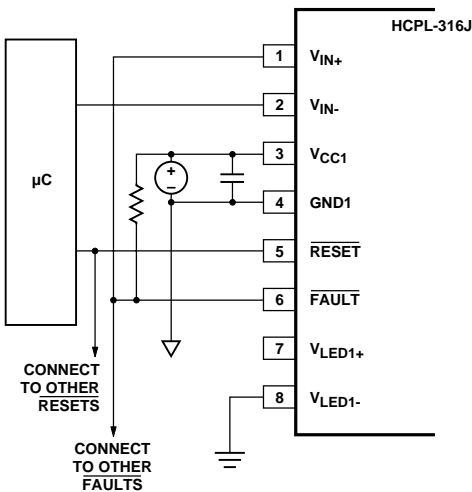

Figure 71. Global-shutdown, global reset configuration.

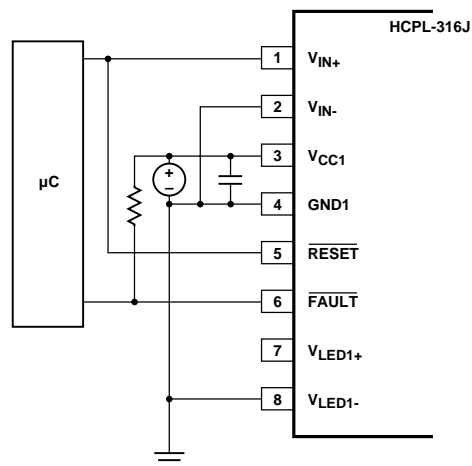

Figure 72. Auto-reset configuration.

continuous PWM signal, the fault latch will always be reset by the next time the input signal goes high. This configuration protects the IGBT on a cycle-by-cycle basis and automatically resets before the next 'on' cycle. The fault outputs can be wire 'OR'ed together to alert the microcontroller, but this signal would not be used for control purposes in this (Auto-Reset) configuration. When the HCPL-316J is configured for Auto-Reset, the guaranteed minimum $\overline{\text{FAULT}}$ signal pulse width is 3 μs .

Resetting Following a Fault Condition

To resume normal switching operation following a fault condition ($\overline{\text{FAULT}}$ output low), the $\overline{\text{RESET}}$ pin must first be asserted low in order to release the internal fault latch and reset the $\overline{\text{FAULT}}$ output (high). Prior to asserting the $\overline{\text{RESET}}$ pin low, the input (V_{IN}) switching signals must be configured for an output (V_{OL}) low state. This can be handled directly by the microcontroller or by hardwiring to synchronize the $\overline{\text{RESET}}$ signal with the appropriate input signal. Figure 73a shows how to connect the $\overline{\text{RESET}}$ to the $V_{\text{IN}+}$ signal for safe automatic reset in the noninverting input configuration. Figure 73b shows how to configure the $V_{\text{IN}+}/\overline{\text{RESET}}$ signals so that a $\overline{\text{RESET}}$ signal from the microcontroller causes the input to be in the "output-off" state. Similarly, Figures 73c and 73d show automatic $\overline{\text{RESET}}$ and microcontroller $\overline{\text{RESET}}$ safe configurations for the inverting input configuration.

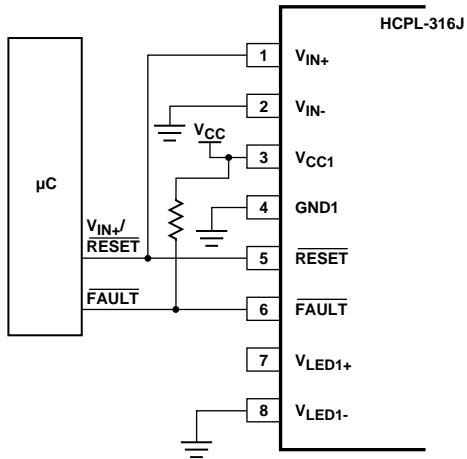

Figure 73a. Safe hardware reset for noninverting input configuration (automatically resets for every V_{IN+} input).

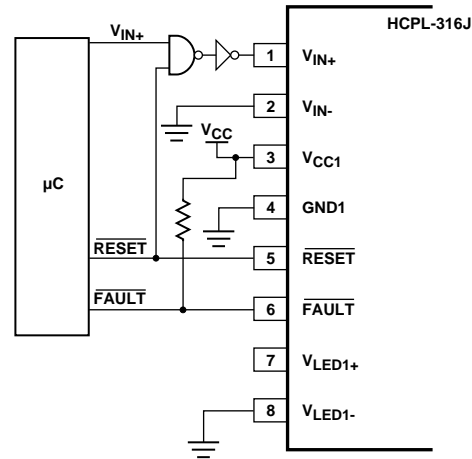

Figure 73b. Safe hardware reset for noninverting input configuration.

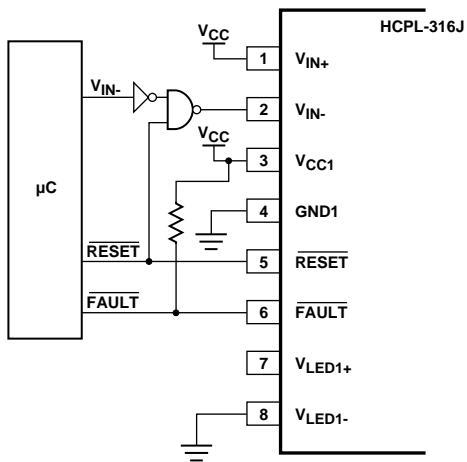

Figure 73c. Safe hardware reset for inverting input configuration.

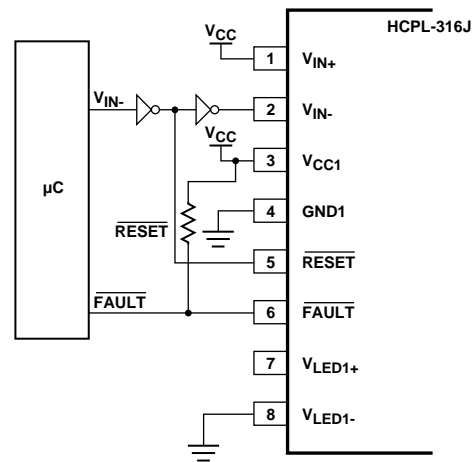

Figure 73d. Safe hardware reset for inverting input configuration (automatically resets for every V_{IN-} input).

User-Configuration of the HCPL-316J Output Side

R_G and Optional Resistor R_C :

The value of the gate resistor R_G (along with V_{CC2} and V_{EE}) determines the maximum amount of gate-charging/discharging current ($I_{ON,PEAK}$ and $I_{OFF,PEAK}$) and thus should be carefully chosen to match the size of the IGBT being driven. Often it is desirable to have the peak gate charge current be somewhat less than the peak

discharge current ($I_{ON,PEAK} < I_{OFF,PEAK}$). For this condition, an optional resistor (R_C) can be used along with R_G to independently determine $I_{ON,PEAK}$ and $I_{OFF,PEAK}$ without using a steering diode. As an example, refer to Figure 74. Assuming that R_G is already determined and that the design $I_{OH,PEAK} = 0.5 \text{ A}$, the value of R_C can be estimated in the following way:

$$\begin{aligned}
 R_C + R_G &= \frac{[V_{CC2} - V_{OH} - (V_{EE})]}{I_{OH,PEAK}} \\
 &= \frac{[4 \text{ V} - (-5 \text{ V})]}{0.5 \text{ A}} \\
 &= 18 \Omega \\
 \Rightarrow R_C &= 8 \Omega
 \end{aligned}$$

See “Power and Layout Considerations” section for more information on calculating value of R_G .

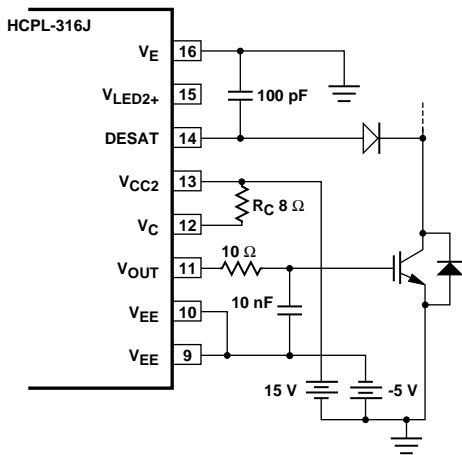

Figure 74. Use of R_C to further limit $I_{ON,PEAK}$.

Higher Output Current Using an External Current Buffer:

To increase the IGBT gate drive current, a non-inverting current buffer (such as the npn/pnp buffer shown in Figure 75) may be used. Inverting types are not compatible with the desaturation fault protection circuitry and should be avoided. To preserve the slow IGBT turn-off feature during a fault condition, a 10 nF capacitor should be connected from the buffer input to V_{EE} and a 10 W resistor inserted between the output and the common npn/pnp base. The MJD44H11/MJD45H11 pair is appropriate for currents up to 8A maximum. The D44VH10/ D45VH10 pair is appropriate for currents up to 15 A maximum.

DESAT Diode and DESAT Threshold

The DESAT diode's function is to conduct forward current, allowing

sensing of the IGBT's saturated collector-to-emitter voltage, V_{CESAT} , (when the IGBT is "on") and to block high voltages (when the IGBT is "off"). During the short period of time when the IGBT is switching, there is commonly a very high dV_{CE}/dt voltage ramp rate across the IGBT's collector-to-emitter. This results in $I_{CHARGE} (= C_{D-DESAT} \times dV_{CE}/dt)$ charging current which will charge the blanking capacitor, C_{BLANK} . In order to minimize this charging current and avoid false DESAT triggering, it is best to use fast response diodes. Listed in the below table are fast-recovery diodes that are suitable for use as a DESAT diode (D_{DESAT}). In the recommended application circuit shown in Figure 62, the voltage on pin 14 (DESAT) is $V_{DESAT} = V_F + V_{CE}$, (where V_F is the forward ON voltage of D_{DESAT} and V_{CE} is the IGBT collector-to-emitter voltage). The value of V_{CE} which triggers DESAT to signal a FAULT condition, is nominally $7V - V_F$. If desired, this DESAT threshold voltage can be decreased by using multiple DESAT diodes in series. If n is the number of DESAT diodes then the nominal threshold value becomes $V_{CE,FAULT(TH)} = 7V - n \times V_F$. In the case of using two diodes instead of one, diodes with half of the total required maximum reverse-voltage rating may be chosen.

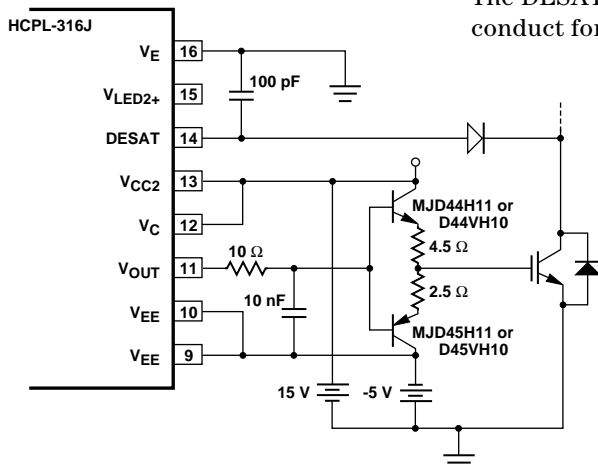

Figure 75. Current buffer for increased drive current.

Part Number	Manufacturer	t_{rr} (ns)	Max. Reverse Voltage Rating, V_{RRM} (Volts)	Package Type
MUR1100E	Motorola	75	1000	59-04 (axial leaded)
MURS160T3	Motorola	75	600	Case 403A (surface mount)
UF4007	General Semi.	75	1000	DO-204AL (axial leaded)
BYM26E	Philips	75	1000	SOD64 (axial leaded)
BYV26E	Philips	75	1000	SOD57 (axial leaded)
BYV99	Philips	75	600	SOD87 (surface mount)

Power/Layout Considerations Operating Within the Maximum Allowable Power Ratings (Adjusting Value of R_G):

When choosing the value of R_G , it

is important to confirm that the power dissipation of the HCPL-316J is within the maximum allowable power rating.

The steps for doing this are:

1. Calculate the minimum desired R_G ;
2. Calculate total power dissipation in the part referring to Figure 77.

(Average switching energy supplied to HCPL-316J per cycle vs. R_G plot);

- Compare the input and output power dissipation calculated in step #2 to the maximum recommended dissipation for the HCPL-316J. (If the maximum recommended level has been exceeded, it may be necessary to raise the value of R_G to lower the switching power and repeat step #2.)

As an example, the total input and output power dissipation can be calculated given the following conditions:

- $I_{ON, MAX} \sim 2.0 \text{ A}$
- $V_{CC2} = 18 \text{ V}$
- $V_{EE} = -5 \text{ V}$
- $f_{CARRIER} = 15 \text{ kHz}$

Step 1: Calculate R_G minimum from I_{OL} peak specification:

To find the peak charging I_{OL} assume that the gate is initially charged the steady-state value of V_{EE} . Therefore apply the following relationship:

$$R_G = \frac{[V_{OH@650 \mu A} - (V_{OL} + V_{EE})]}{I_{OL, PEAK}}$$

$$= \frac{[V_{CC2} - 1 - (V_{OL} + V_{EE})]}{I_{OL, PEAK}}$$

$$= \frac{18 \text{ V} - 1 \text{ V} - (1.5 \text{ V} + (-5 \text{ V}))}{2.0 \text{ A}}$$

$$= 10.25 \text{ W}$$

$$\approx 10.5 \text{ W (for a 1% resistor)}$$

(Note from Figure 76 that the real value of I_{OL} may vary from the value calculated from the simple model shown.)

Step 2: Calculate total power dissipation in the HCPL-316J:

The HCPL-316J total power dissipation (P_T) is equal to the sum of the input-side power (P_I)

and output-side power (P_O):

$$P_T = P_I + P_O$$

$$P_I = I_{CC1} * V_{CC1}$$

$$P_O = P_{O(BIAS)} + P_{O, SWTICH}$$

$$= I_{CC2} * (V_{CC2} - V_{EE}) + E_{SWTICH} * f_{SWTICH}$$

where,

$P_{O(BIAS)}$ = steady-state power dissipation in the HCPL-316J due to biasing the device.

$P_{O(SWTICH)}$ = transient power dissipation in the HCPL-316J due to charging and discharging power device gate.

E_{SWTICH} = Average Energy dissipated in HCPL-316J due to switching of the power device over one switching cycle ($\mu\text{J}/\text{cycle}$).

f_{SWTICH} = average carrier signal frequency.

For $R_G = 10.5$, the value read from Figure 77 is $E_{SWTICH} = 6.05 \mu\text{J}$. Assume a worst-case average $I_{CC1} = 16.5 \text{ mA}$ (which is given by the average of I_{CC1H} and I_{CC1L}). Similarly the average $I_{CC2} = 5.5 \text{ mA}$.

$$P_I = 16.5 \text{ mA} * 5.5 \text{ V} = 90.8 \text{ mW}$$

$$P_O = P_{O(BIAS)} + P_{O, SWTICH}$$

$$= 5.5 \text{ mA} * (18 \text{ V} - (-5 \text{ V})) + 6.051 \mu\text{J} * 15 \text{ kHz}$$

$$= 126.5 \text{ mW} + 90.8 \text{ mW}$$

$$= 217.3 \text{ mW}$$

Step 3: Compare the calculated power dissipation with the absolute maximum values for the HCPL-316J:

For the example,

$$P_I = 90.8 \text{ mW} < 150 \text{ mW (abs. max.)} \Rightarrow \text{OK}$$

$$P_O = 217.3 \text{ mW} < 400 \text{ mW (abs. max.)} \Rightarrow \text{OK}$$

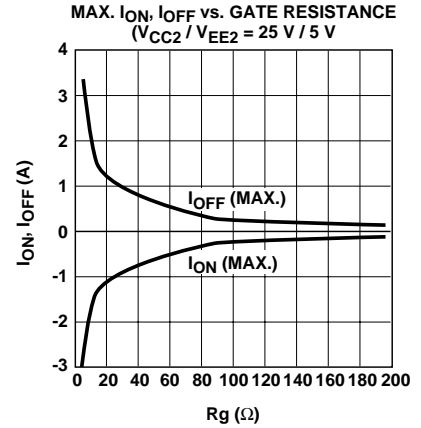

Figure 76. Typical peak I_{ON} and I_{OFF} currents vs. R_g (for HCPL-316J output driving an IGBT rated at 600 V/100 A).

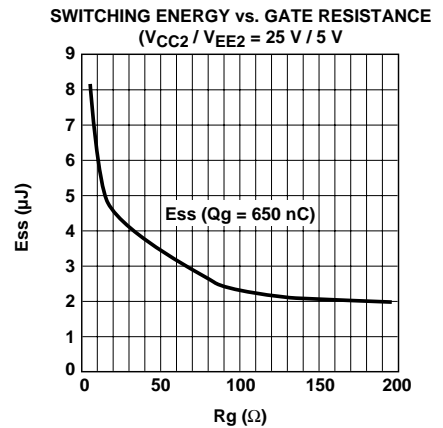

Figure 77. Switching energy plot for calculating average P_{switch} (for HCPL-316J output driving an IGBT rated at 600 V/100 A).

Therefore, the power dissipation absolute maximum rating has not been exceeded for the example.

Please refer to the following **Thermal Model** section for an explanation on how to calculate the maximum junction temperature of the HCPL-316J for a given PC board layout configuration.

Thermal Model

The HCPL-316J is designed to dissipate the majority of the heat through pins 4 for the input IC and pins 9 and 10 for the output IC. (There are two V_{EE} pins on the output side, pins 9 and 10, for this purpose.) Heat flow through other pins or through the package directly into ambient are considered negligible and not modeled here.

In order to achieve the power dissipation specified in the absolute maximum specification, it is imperative that pins 4, 9, and 10 have ground planes connected to them. As long as the maximum power specification is not exceeded, the only other limitation to the amount of power one can dissipate is the absolute maximum junction temperature specification of 125°C. The junction temperatures can be calculated with the following equations:

$$T_{ji} = P_i (\theta_{i4} + \theta_{4A}) + T_A$$

$$T_{jo} = P_o (\theta_{o9,10} + \theta_{9,10A}) + T_A$$

where P_i = power into input IC and P_o = power into output IC.

Since θ_{4A} and $\theta_{9,10A}$ are dependent on PCB layout and airflow, their exact number may not be available. Therefore, a more accurate method of calculating the junction temperature is with the following equations:

$$T_{ji} = P_i \theta_{i4} + T_{P4}$$

$$T_{jo} = P_o \theta_{o9,10} + T_{P9,10}$$

These equations, however, require that the pin 4 and pins 9, 10 temperatures be measured with a thermal couple on the pin at the HCPL-316J package edge.

From the earlier power dissipation calculation example:

P_i = 90.8 mW, P_o = 314 mW, T_A = 100°C, and assuming the thermal model shown in Figure 77 below.

$$T_{ji} = (90.8 \text{ mW})(60^\circ\text{C/W} + 50^\circ\text{C/W}) + 100^\circ\text{C} = 110^\circ\text{C}$$

$$T_{jo} = (240 \text{ mW})(30^\circ\text{C/W} + 50^\circ\text{C/W}) + 100^\circ\text{C} = 119^\circ\text{C}$$

both of which are within the absolute maximum specification of 125°C.

If we, however, assume a worst case PCB layout and no air flow where the estimated θ_{4A} and $\theta_{9,10A}$ are 100°C/W. Then the junction temperatures become

$$T_{ji} = (90.8 \text{ mW})(60^\circ\text{C/W} + 100^\circ\text{C/W}) + 100^\circ\text{C} = 115^\circ\text{C}$$

$$T_{jo} = (240 \text{ mW})(30^\circ\text{C/W} + 100^\circ\text{C/W}) + 100^\circ\text{C} = 131^\circ\text{C}$$

The output IC junction temperature exceeds the absolute maximum specification of 125°C. In this case, PCB layout and airflow will need to be designed so that the junction temperature of the output IC does not exceed 125°C.

If the calculated junction temperatures for the thermal model in Figure 78 is higher than 125°C, the pin temperature for pins 9 and 10 should be measured (at the package edge) under worst case operating environment for a more accurate estimate of the junction temperatures.

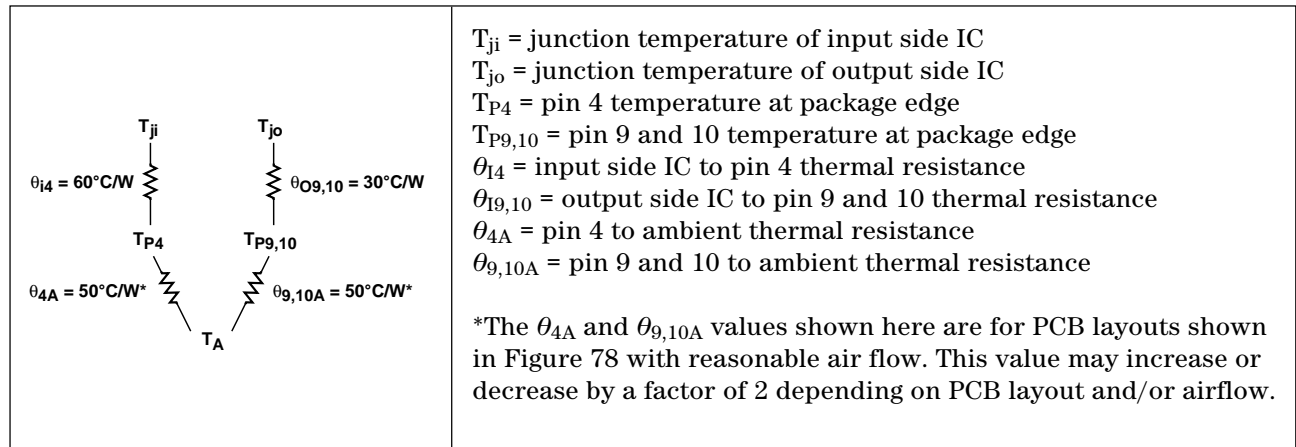

Figure 78. HCPL-316J thermal model.

Printed Circuit Board Layout Considerations

Adequate spacing should always be maintained between the high voltage isolated circuitry and any input referenced circuitry. Care must be taken to provide the same minimum spacing between two adjacent high-side isolated regions of the printed circuit board. Insufficient spacing will reduce the effective isolation and increase parasitic coupling that will degrade CMR performance.

The placement and routing of supply bypass capacitors

requires special attention. During switching transients, the majority of the gate charge is supplied by the bypass capacitors. Maintaining short bypass capacitor trace lengths will ensure low supply ripple and clean switching waveforms.

Ground Plane connections are necessary for pin 4 (GND1) and pins 9 and 10 (V_{EE}) in order to achieve maximum power dissipation as the HCPL-316J is designed to dissipate the majority of heat generated through these pins. Actual power dissipation will depend

on the application environment (PCB layout, air flow, part placement, etc.) See the Thermal Model section for details on how to estimate junction temperature.

The layout examples below have good supply bypassing and thermal properties, exhibit small PCB footprints, and have easily connected signal and supply lines. The four examples cover single sided and double sided component placement, as well as minimal and improved performance circuits.

Minimum Components placed on two sides

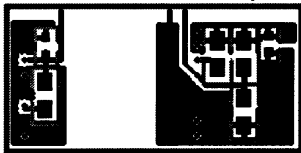
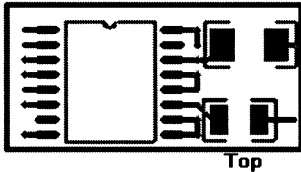

Total Area= 0.39 sq. in.

Maximum Components placed on two sides

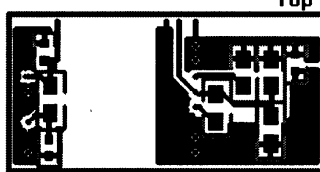
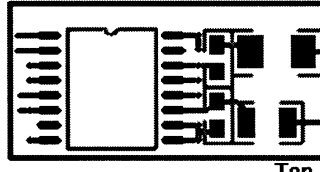

Total Area= 0.46 sq. in.

Minimum Components placed on one side

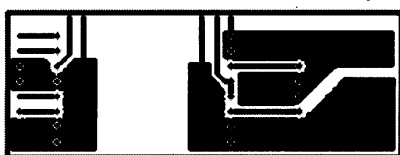
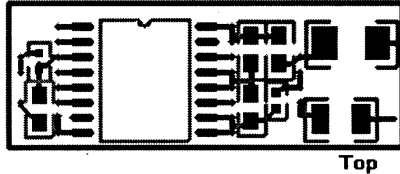

Total Area= 0.54 sq. in.

Maximum Components placed on one side

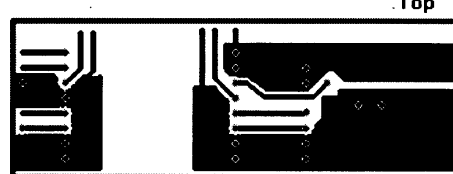
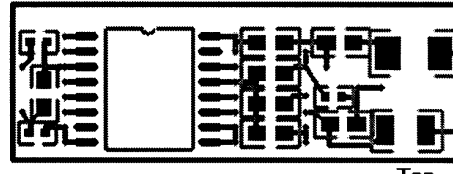

Total Area= 0.61 sq. in.

Figure 79. Recommended layout(s).

System Considerations

Propagation Delay Difference (PDD)

The HCPL-316J includes a Propagation Delay Difference (PDD) specification intended to help designers minimize “dead time” in their power inverter designs. Dead time is the time period during which both the high and low side power transistors (Q1 and Q2 in Figure 62) are off. Any overlap in Q1 and Q2 conduction will result in large currents flowing through the power devices between the high and low voltage motor rails, a potentially catastrophic condition that must be prevented.

To minimize dead time in a given design, the turn-on of the HCPL-316J driving Q2 should be delayed (relative to the turn-off of the HCPL-316J driving Q1) so that under worst-case

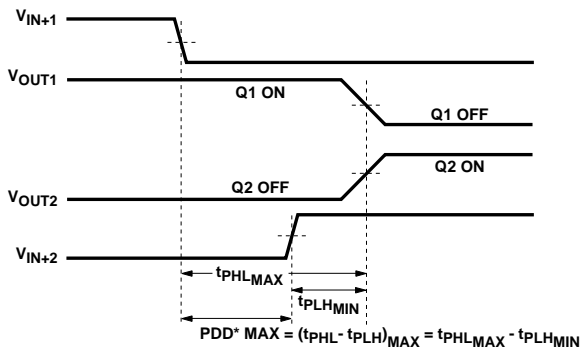

*PDD = PROPAGATION DELAY
NOTE: FOR PDD CALCULATIONS THE PROPAGATION DELAYS ARE TAKEN AT THE SAME TEMPERATURE AND TEST CONDITIONS.

Figure 80. Minimum LED Skew for Zero Dead Time.

conditions, transistor Q1 has just turned off when transistor Q2 turns on, as shown in Figure 80. The amount of delay necessary to achieve this condition is equal to the maximum value of the propagation delay difference specification, PDD_{MAX} , which is specified to be 400 ns over the operating temperature range of -40°C to 100°C .

Delaying the HCPL-316J turn-on signals by the maximum propagation delay difference ensures that the minimum dead time is zero, but it does not tell a designer what the maximum dead time will be. The maximum

dead time is equivalent to the difference between the maximum and minimum propagation delay difference specifications as shown in Figure 81. The maximum dead time for the HCPL-316J is 800 ns ($= 400\text{ ns} - (-400\text{ ns})$) over an operating temperature range of -40°C to 100°C .

Note that the propagation delays used to calculate PDD and dead time are taken at equal temperatures and test conditions since the optocouplers under consideration are typically mounted in close proximity to each other and are switching identical IGBTs.

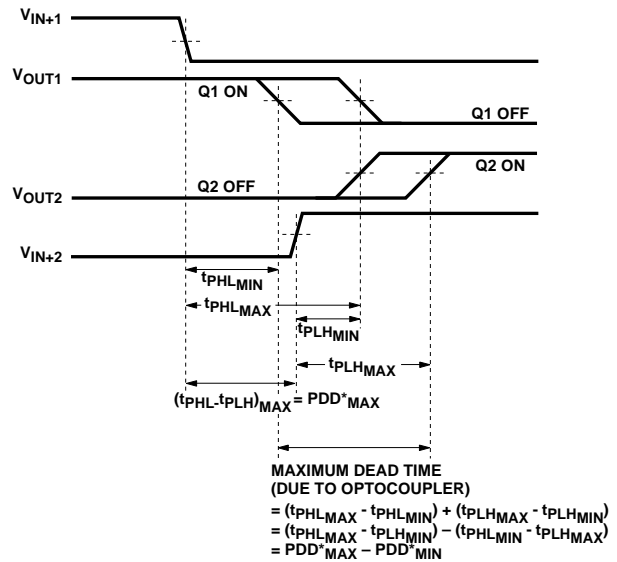

*PDD = PROPAGATION DELAY DIFFERENCE
NOTE: FOR DEAD TIME AND PDD CALCULATIONS ALL PROPAGATION DELAYS ARE TAKEN AT THE SAME TEMPERATURE AND TEST CONDITIONS.

Figure 81. Waveforms for Dead Time Calculation.

www.agilent.com/semiconductors

For product information and a complete list of distributors, please go to our web site.

For technical assistance call:

Americas/Canada: +1 (800) 235-0312 or
(916) 788-6763

Europe: +49 (0) 6441 92460

China: 10800 650 0017

Hong Kong: (+65) 6756 2394

India, Australia, New Zealand: (+65) 6755 1939

Japan: (+81 3) 3335-8152(Domestic/International), or 0120-61-1280(Domestic Only)

Korea: (+65) 6755 1989

Singapore, Malaysia, Vietnam, Thailand,
Philippines, Indonesia: (+65) 6755 2044

Taiwan: (+65) 6755 1843

Data subject to change.

Copyright © 2005 Agilent Technologies, Inc.

Obsoletes 5989-2143EN

May 3, 2005

5989-2945EN



Agilent Technologies