



# Winstar Display Co., LTD

## 華凌光電股份有限公司



住址: 407 台中市中清路 163 號  
No.163 Chung Ching RD.,  
Taichune, Taiwan, R.O.C

WEB: <http://www.winstar.com.tw>  
E-mail: sales@winstar.com.tw  
Tel:886-4-24262208 Fax : 886-4-24262207

### SPECIFICATION

**CUSTOMER :** \_\_\_\_\_

**MODULE NO.:**           WO12864C2-TFH#          

<p><b>APPROVED BY:</b> ( FOR CUSTOMER USE ONLY )</p>	<p><b>PCB VERSION:    DATA:</b></p>
--	-------------------------------------

SALES BY	APPROVED BY	CHECKED BY	PREPARED BY

VERSION	DATE	REVISED PAGE NO.	SUMMARY
0	2009/2/11		First issue

MODLE NO :

**RECORDS OF REVISION**

**DOC. FIRST ISSUE**

VERSION	DATE	REVISED PAGE NO.	<b>SUMMARY</b>
0	2009/2/11		First issue

# Contents

1. Module Classification Information
2. Precautions in use of LCD Modules
3. General Specification
4. Absolute Maximum Ratings
5. Electrical Characteristics
6. Optical Characteristics
7. Interface Pin Function
8. Contour Drawing & Block Diagram
9. Timing Characteristics
10. Display Command
11. Reliability
12. Backlight Information
13. Inspection specification
14. Material List of Components for RoHs

# 1.Module Classification Information

W O   12864   C2— T F H   #  
 ① ②            ③            ④            ⑤ ⑥ ⑦            ⑧

- ① Brand : WINSTAR DISPLAY CORPORATION
- ② Display Type : H→Character Type, G→Graphic Type O→COG Type
- ③ Display Font : 128 x 64 dots
- ④ Model serials no.
- ⑤ Backlight Type :      N→Without backlight              T→LED, White  
                                   B→EL, Blue green                    A→LED, Amber  
                                   D→EL, Green                            R→LED, Red  
                                   W→EL, White                            O→LED, Orange  
                                   F→CCFL, White                        G→LED, Green  
                                   Y→LED, Yellow Green                P→LED, Blue
- ⑥ LCD Mode :            B→TN Positive, Gray                T→FSTN Negative  
                                   N→TN Negative,  
                                   G→STN Positive, Gray  
                                   Y→STN Positive, Yellow Green  
                                   M→STN Negative, Blue  
                                   F→FSTN Positive
- ⑦ LCD Polarize            A→Reflective, N.T, 6:00            H→Transflective, W.T,6:00  
   Type/ Temperature    D→Reflective, N.T, 12:00            K→Transflective, W.T,12:00  
   range/ View            G→Reflective, W. T, 6:00            C→Transmissive, N.T,6:00  
   direction                J→Reflective, W. T, 12:00            F→Transmissive, N.T,12:00  
                                   B→Transflective, N.T,6:00            I→Transmissive, W. T, 6:00  
                                   E→Transflective, N.T.12:00        L→Transmissive, W.T,12:00
- ⑧ Special Code            #:Fit in with the ROHS Directions and regulations

## 2. Precautions in use of LCD Modules

- (1) Avoid applying excessive shocks to the module or making any alterations or modifications to it.
- (2) Don't make extra holes on the printed circuit board, modify its shape or change the components of LCD module.
- (3) Don't disassemble the LCM.
- (4) Don't operate it above the absolute maximum rating.
- (5) Don't drop, bend or twist LCM.
- (6) Soldering: only to the I/O terminals.
- (7) Storage: please storage in anti-static electricity container and clean environment.
- (8). Winstar have the right to change the passive components
- (9). Winstar have the right to change the PCB Rev.

## 3. General Specification

<b>Item</b>	<b>Dimension</b>	<b>Unit</b>
Number of Characters	128 x 64 dots	—
Module dimension	55.2x 39.8 x 6.5(MAX)	mm
View area	45.2 x 27.0	mm
Active area	40.92 x 24.28	mm
Dot size	0.28 x 0.34	mm
Dot pitch	0.32 x 0.38	mm
LCD type	FSTN Positive Transflective (In LCD production, It will occur slightly color difference. We can only guarantee the same color in the same batch.)	
Duty	1/64 , 1/9 Bias	
View direction	6 o'clock	
Backlight Type	LED White	

## 4. Absolute Maximum Ratings

Item	Symbol	Min	Typ	Max	Unit
Operating Temperature	$T_{OP}$	-20	—	+70	°C
Storage Temperature	$T_{ST}$	-30	—	+80	°C
Input Voltage	$V_I$	-0.3	—	$V_{DD}+0.3$	V
Supply Voltage For Logic	$V_{DD}-V_{SS}$	-0.3		5.0	V
LCD Driver Supply Voltage	$V_{OUT}$	4		13	V

## 5. Electrical Characteristics

Item	Symbol	Condition	Min	Typ	Max	Unit
Supply Voltage For Logic	$V_{DD}-V_{SS}$	—	2.7	3.0	3.3	V
Supply Voltage For LCM	$V_{DD}-V_5$	$T_a=-20^{\circ}C$	9.1	9.3	9.5	V
		$T_a=25^{\circ}C$	8.8	9.0	9.2	V
		$T_a=70^{\circ}C$	8.6	8.8	9.0	V
Input High Volt.	$V_{IH}$	—	$0.8 V_{DD}$	—	$V_{DD}$	V
Input Low Volt.	$V_{IL}$	—	$V_{SS}$	—	$0.2 V_{DD}$	V
Output High Volt.	$V_{OH}$	—	$0.8 V_{DD}$	—	$V_{DD}$	V
Output Low Volt.	$V_{OL}$	—	$V_{SS}$	—	$0.2V_{DD}$	V
Supply Current(No include LED Backlight)	$I_{DD}$	$V_{DD}=3.0V$		0.49	1	mA

# 6. Optical Characteristics

Item	Symbol	Condition	Min	Typ	Max	Unit
View Angle	(V) $\theta$	$CR \geq 2$	30	—	60	deg
	(H) $\varphi$	$CR \geq 2$	-45	—	45	deg
Contrast Ratio	CR	—	—	5	—	—
Response Time	T rise	—	—	230	330	ms
	T fall	—	—	170	270	ms

### Definition of Operation Voltage (Vop)

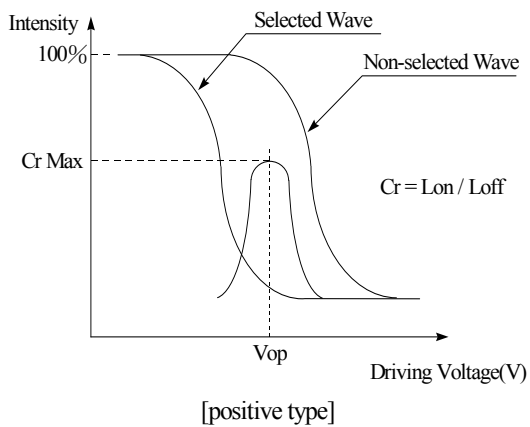

### Definition of Response Time (Tr, Tf)

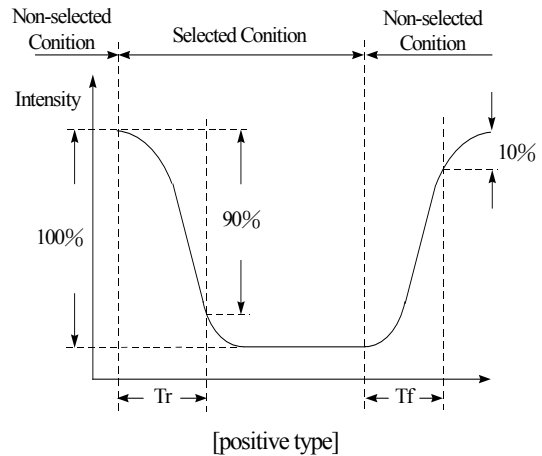

### Conditions :

Operating Voltage : Vop

Frame Frequency : 64 HZ

Viewing Angle( $\theta$  ,  $\varphi$ ) :  $0^\circ$  ,  $0^\circ$

Driving Waveform : 1/N duty , 1/a bias

### Definition of viewing angle( $CR \geq 2$ )

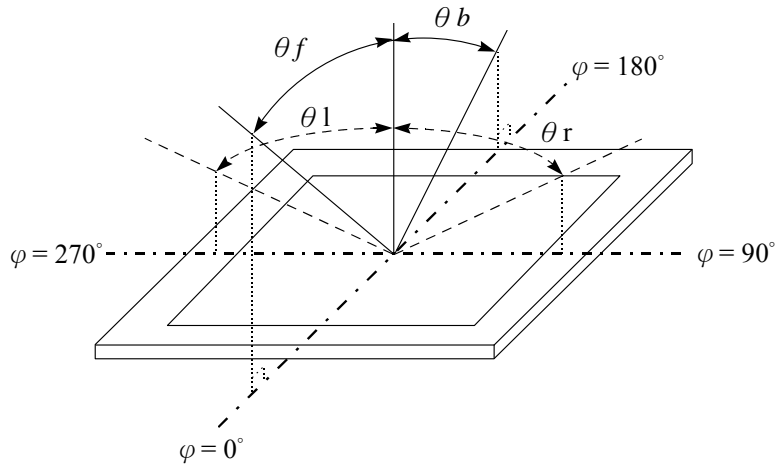

## 7. Interface Pin Function

Pin No.	Symbol	Level	Description															
1	IRS		<p>This terminal selects the resistors for the V5 voltage level adjustment.</p> <p>IRS = "H": Use the internal resistors.</p> <p>IRS = "L": Do not use the internal resistors.</p> <p>The V5 voltage level is regulated by an external resistive voltage divider attached to the VR terminal. This pin is enabled only when the master operation mode is selected. It is fixed to either "H" or "L" when the slave operation mode is selected.</p>															
2	/HPM		<p>This is the power control terminal for the power supply circuit for liquid crystal drive.</p> <p>HPM="H": Normal mode</p> <p>HPM="L": High power mode</p>															
3	P/S		<p>This is the parallel data input/serial data input switch terminal.</p> <p>P/S = "H": Parallel data input.</p> <p>P/S = "L": Serial data input.</p> <p>The following applies depending on the PS status:</p> <table border="1" style="margin-left: 20px;"> <thead> <tr> <th>P/S</th> <th>Data/Command</th> <th>Data</th> <th>Read/Write</th> <th>Serial Clock</th> </tr> </thead> <tbody> <tr> <td>"H"</td> <td>A0</td> <td>DB0 ~ DB7</td> <td>/RD, /WR</td> <td>X</td> </tr> <tr> <td>"L"</td> <td>A0</td> <td>SI (DB7)</td> <td>Write only</td> <td>SCL (DB6)</td> </tr> </tbody> </table> <p>When P/S = "L", DB0 to DB5 fixed "H".</p> <p>/RD (EP) and /WR (RWP) are fixed to either "H" or "L".</p> <p>With serial data input, It is impossible read data from RAM .</p>	P/S	Data/Command	Data	Read/Write	Serial Clock	"H"	A0	DB0 ~ DB7	/RD, /WR	X	"L"	A0	SI (DB7)	Write only	SCL (DB6)
P/S	Data/Command	Data	Read/Write	Serial Clock														
"H"	A0	DB0 ~ DB7	/RD, /WR	X														
"L"	A0	SI (DB7)	Write only	SCL (DB6)														
4	C86		<p>This is the MPU interface switch terminal.</p> <p>C86 = "H": 6800 Series MPU interface.</p> <p>C86 = "L": 8080 MPU interface.</p>															
5	VR		<p>Output voltage regulator terminal. Provides the voltage between VDD and V5 through a resistive voltage divider.</p> <p>These are only enabled when the V5 voltage regulator internal resistors are not used (IRS = "L"). These cannot be used when the V5 voltage regulator internal resistors are used (IRS = "H").</p>															

6	V5		A multi-level power supply for the liquid crystal drive. The voltage applied is determined by the liquid crystal cell, and is changed through the use of a resistive voltage divider or through changing the impedance using an op. amp. Voltage levels are determined based on VDD, and must maintain the relative magnitudes shown below. $VDD (= V0) \geq V1 \geq V2 \geq V3 \geq V4 \geq V5$
7	V4		
8	V3		
9	V2		
10	V1		
11	VRS		This is the internal-input VREG power supply for the lcd power supply
12	CAP4-		DC/DC voltage converter. Connect a capacitor between this terminal and C2+
13	C2+		DC/DC voltage converter. Connect a capacitor between this terminal and C2-
14	CAP2-		DC/DC voltage converter. Connect a capacitor between this terminal and C2+
15	CAP1-		DC/DC voltage converter. Connect a capacitor between this terminal and C1+
16	CAP1+		DC/DC voltage converter. Connect a capacitor between this terminal and C1-
17	CAP3-		DC/DC voltage converter. Connect a capacitor between this terminal and C1+
18	CAP5-		DC/DC voltage converter. Connect a capacitor between this terminal and C1+
19	VOUT		DC/DC voltage converter. Connect a capacitor between this terminal and VSS
20	Vss		Power Supply (VSS=0)
21	VDD		Power Supply (VDD=3.0)
22	DB7		This is an 8-bit bi-directional data bus that connects to an 8-bit or 16-bit standard MPU data bus. When the serial interface is selected (PS = "L"), DB7 serves as the serial data input terminal (SI) and DB6 serves as the serial clock input terminal (SCL). At the same time, DB5 - 0 are set to high impedance. When the chip select is inactive, DB0 to DB7 are set to high impedance.
23	DB6		
24	DB5		
25	DB4		
26	DB3		
27	DB2		
28	DB1		
29	DB0		
30	/RD(E)		When connected to an 8080 MPU, this is LOW active. This pin is connected to the RD signal of the 8080 MPU, and the ST7565S series data bus is in an output status when this signal is "L". When connected to a 6800 Series MPU, this is active HIGH. This is the 6800 Serier MPU enable clock input terminal.

31	/WR(RW)	<p>When connected to an 8080 MPU, this is LOW active. This pin is connected to the RD signal of the 8080 MPU, and the ST7565S series data bus is in an output status when this signal is "L".</p> <p>When connected to a 6800 Series MPU, this is active HIGH. This is the 6800 Serier MPU enable clock input terminal.</p>
32	A0	<p>This is connect to the least significant bit of the normal MPU address bus, and it determines whether the data bits are data or a command.</p> <p>A0 = "H": Indicates that DB0 to DB7 are display data.</p> <p>A0 = "L": Indicates that DB0 to DB7 are control data.</p>
33	/RES	<p>/RES is set to "L", the settings are initialized.</p> <p>The /RES signal level performs the reset operation.</p>
34	/CS1	<p>This is the chip select signal. When /CS1 = "L", then the chip select becomes active, and data/command I/O is enabled.</p>

# 8. Contour Drawing & Block Diagram

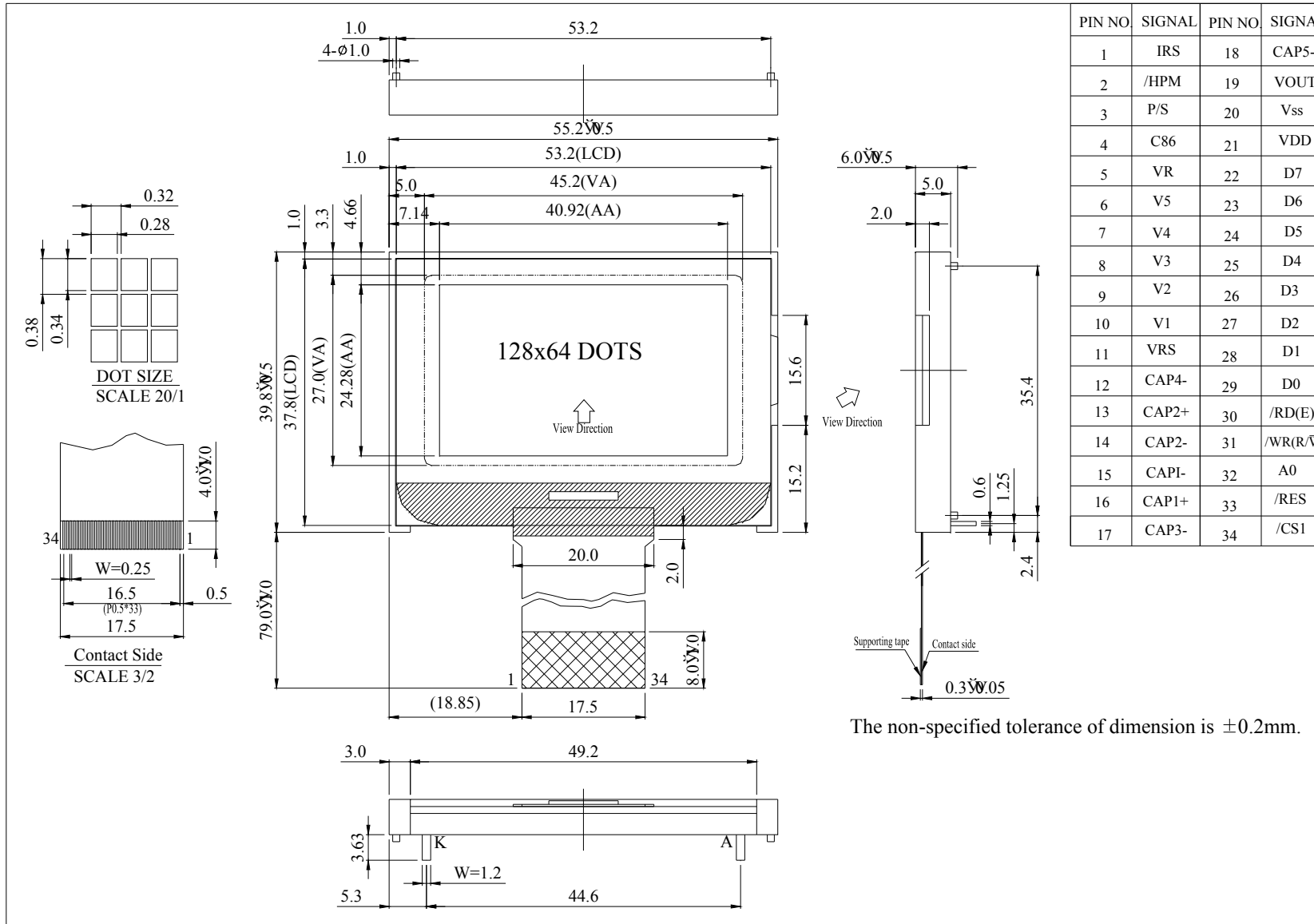

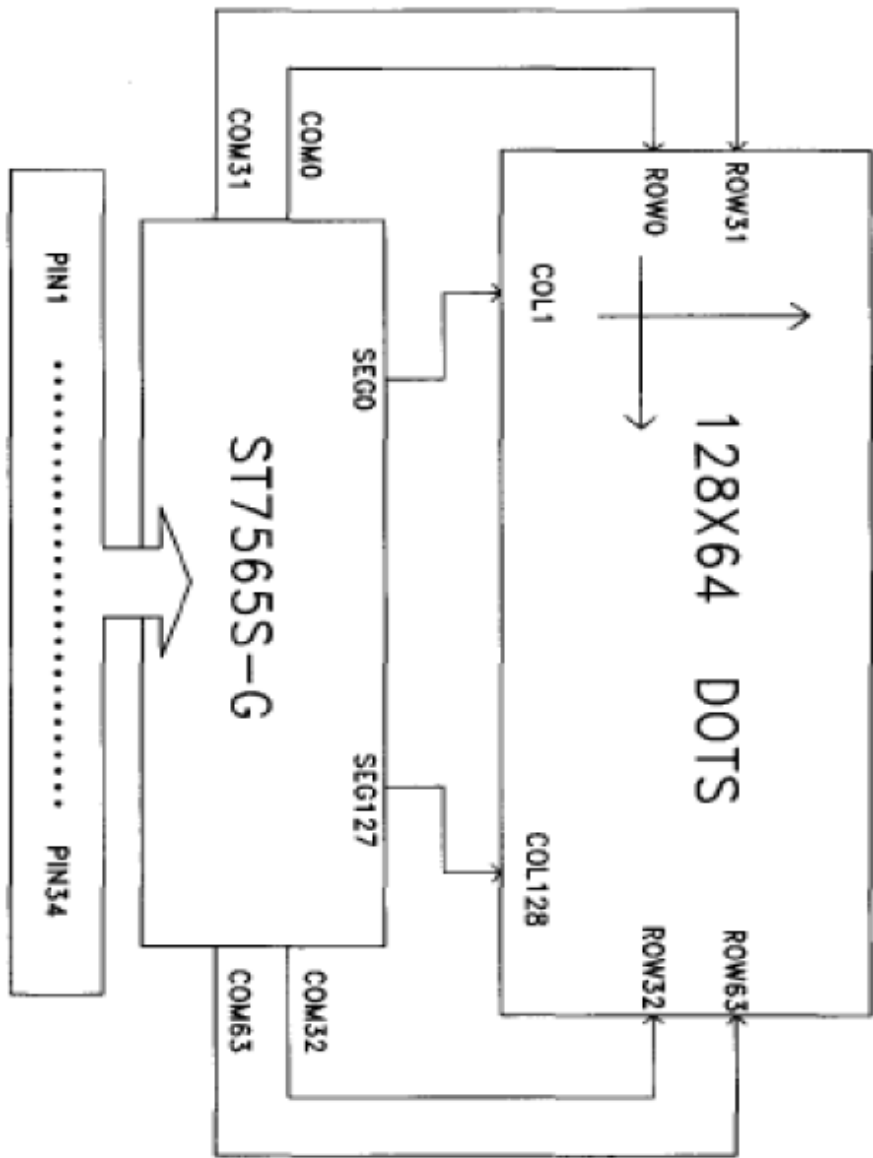

PIN NO.	SIGNAL	PIN NO.	SIGNAL
1	IRS	18	CAP5-
2	/HPM	19	VOUT
3	P/S	20	Vss
4	C86	21	VDD
5	VR	22	D7
6	V5	23	D6
7	V4	24	D5
8	V3	25	D4
9	V2	26	D3
10	V1	27	D2
11	VRS	28	D1
12	CAP4-	29	D0
13	CAP2+	30	/RD(E)
14	CAP2-	31	/WR(R/W)
15	CAP1-	32	A0
16	CAP1+	33	/RES
17	CAP3-	34	/CS1

## 9. Timing Characteristics

FOR 6800Series MPU

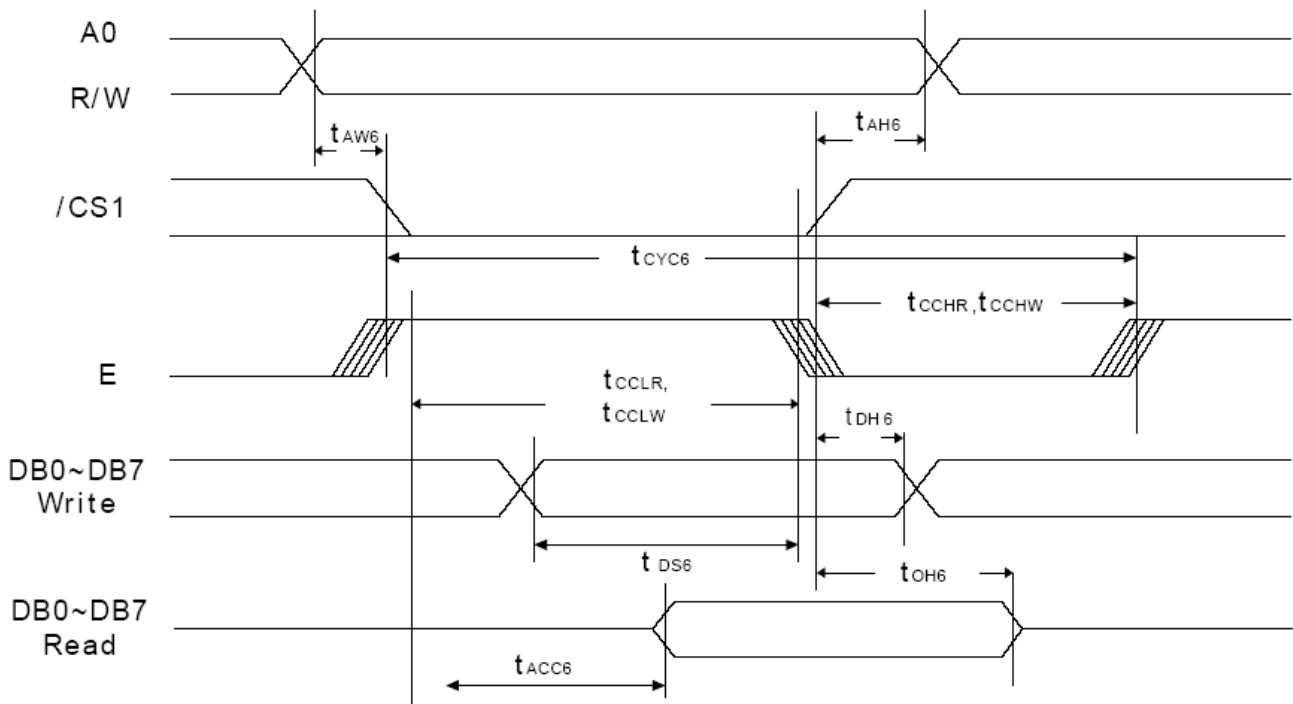

(  $V_{DD} = 3.3V$  ,  $T_a = 25^\circ$  )

Item	Signal	Symbol	Condition	Rating		Units
				Min	Max	
Address hold time	A0	$t_{AH8}$	-	0	-	ns
Address setup time		$t_{AW8}$	-	0	-	
System cycle time		$t_{CYC8}$	-	240	-	
Control L pulse width (/WR)	/WR	$t_{CCLW}$	-	80	-	
Control H pulse width (/WR)		$t_{CCHW}$	-	80	-	
Control L pulse width (/RD)	/RD	$t_{CCLR}$	-	80	-	
Control H pulse width (/RD)		$t_{CCHR}$	-	140	-	
WRITE Data setup time	DB0 to DB7	$t_{DS8}$	-	40	-	
WRITE Address hold time		$t_{DH8}$	-	0	-	
READ access time		$t_{ACC8}$	$C_L = 100pF$	-	70	
READ Output disable time		$t_{OH8}$	$C_L = 100pF$	5	50	

(  $V_{DD} = 2.7v$  ,  $T_a = 25^\circ$  )

Item	Signal	Symbol	Condition	Rating		Units
				Min	Max	
Address hold time	A0	$t_{AH8}$	-	0	-	ns
Address setup time		$t_{AW8}$	-	0	-	
System cycle time		$t_{CYC8}$	-	400	-	
Control L pulse width (/WR)	/WR	$t_{CCLW}$	-	220	-	
Control H pulse width (/WR)		$t_{CCHW}$	-	180	-	
Control L pulse width (/RD)	/RD	$t_{CCLR}$	-	220	-	
Control H pulse width (/RD)		$t_{CCHR}$	-	180	-	
WRITE Data setup time	DB0 to DB7	$t_{DS8}$	-	40	-	
WRITE Address hold time		$t_{DH8}$	-	0	-	
READ access time		$t_{ACC8}$	$C_L = 100pF$	-	140	
READ Output disable time		$t_{OH8}$	$C_L = 100pF$	10	100	

FOR 8080 Series MPU

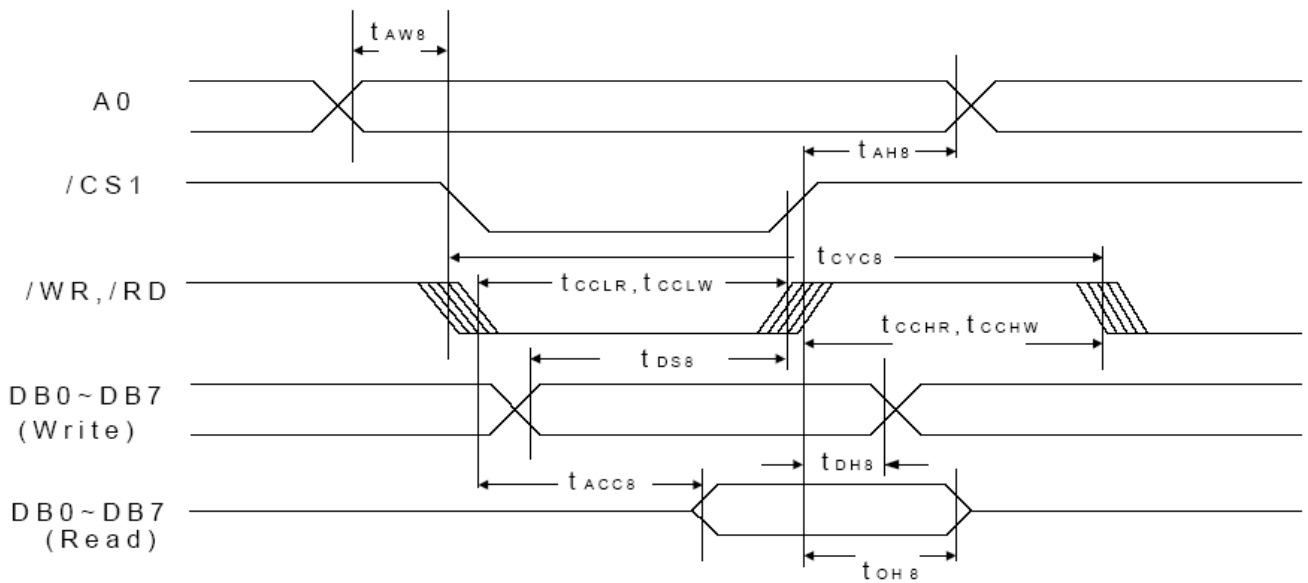

(  $V_{DD} = 3.3v$  ,  $T_a = 25^\circ$  )

Item	Signal	Symbol	Condition	Rating		Units
				Min	Max	
Address hold time	A0	$t_{AH8}$	-	0	-	ns
Address setup time		$t_{AW8}$	-	0	-	
System cycle time		$t_{CYC8}$	-	240	-	
Control L pulse width (/WR)	/WR	$t_{CCLW}$	-	80	-	
Control H pulse width (/WR)		$t_{CCHW}$	-	80	-	
Control L pulse width (/RD)	/RD	$t_{CCLR}$	-	140	-	
Control H pulse width (/RD)		$t_{CCHR}$	-	80	-	
WRITE Data setup time	DB0 to DB7	$t_{DS8}$	-	40	-	
WRITE Address hold time		$t_{DH8}$	-	0	-	
READ access time		$t_{ACC8}$	$C_L=100pF$	-	70	
READ Output disable time		$t_{OH8}$	$C_L=100pF$	5	50	

(  $V_{DD} = 2.7v$  ,  $T_a = 25^\circ$  )

Item	Signal	Symbol	Condition	Rating		Units
				Min	Max	
Address hold time	A0	$t_{AH8}$	-	0	-	ns
Address setup time		$t_{AW8}$	-	0	-	
System cycle time		$t_{CYC8}$	-	400	-	
Control L pulse width (/WR)	/WR	$t_{CCLW}$	-	220	-	
Control H pulse width (/WR)		$t_{CCHW}$	-	180	-	
Control L pulse width (/RD)	/RD	$t_{CCLR}$	-	220	-	
Control H pulse width (/RD)		$t_{CCHR}$	-	180	-	
WRITE Data setup time	DB0 to DB7	$t_{DS8}$	-	40	-	
WRITE Address hold time		$t_{DH8}$	-	0	-	
READ access time		$t_{ACC8}$	$C_L=100pF$	-	140	
READ Output disable time		$t_{OH8}$	$C_L=100pF$	10	100	

Serial Interface

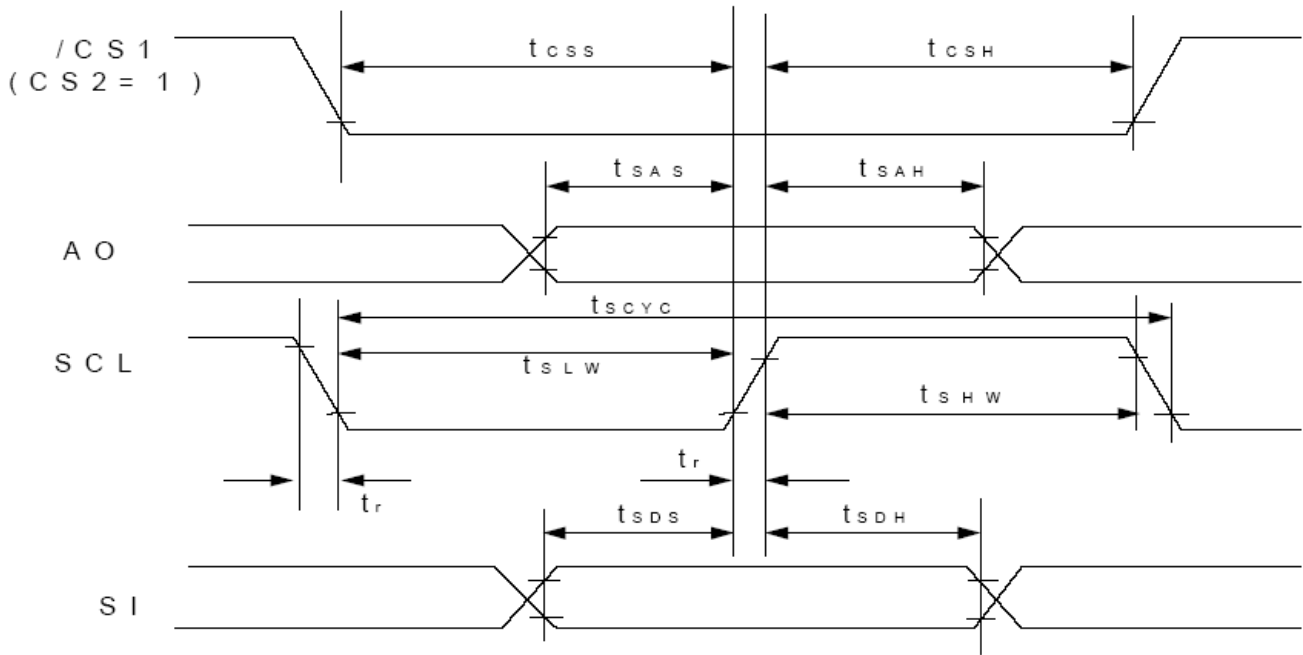

(  $V_{DD} = 3.3v$  ,  $T_a = 25^\circ$  )

Item	Signal	Symbol	Condition	Rating		Units
				Min	Max	
Serial Clock Period	SCL	$t_{scyc}$		50	-	ns
SCL "H" pulse width		$t_{shw}$		25	-	
SCL "L" pulse width		$t_{slw}$		25	-	
Address setup time	A0	$t_{sas}$		20	-	
Address hold time		$t_{sah}$		10	-	
Data setup time	SI	$t_{lds}$		20	-	
Data hold time		$t_{ldh}$		10	-	
CS-SCL time	CS	$t_{css}$		20		
CS-SCL time		$t_{ssh}$		40		

(  $V_{DD} = 2.7V$  ,  $T_a = 25^\circ$  )

Item	Signal	Symbol	Condition	Rating		Units
				Min	Max	
Serial Clock Period	SCL	tSCYC		100	-	ns
SCL "H" pulse width		tSHW		50	-	
SCL "L" pulse width		tSLW		50	-	
Address setup time	A0	tsAS		30	-	
Address hold time		tsAH		20	-	
Data setup time	SI	tsDS		30	-	
Data hold time		tsDH		20	-	
CS-SCL time	CS	tcSS		30		
CS-SCL time		tSSh		60		

### Reset Timing

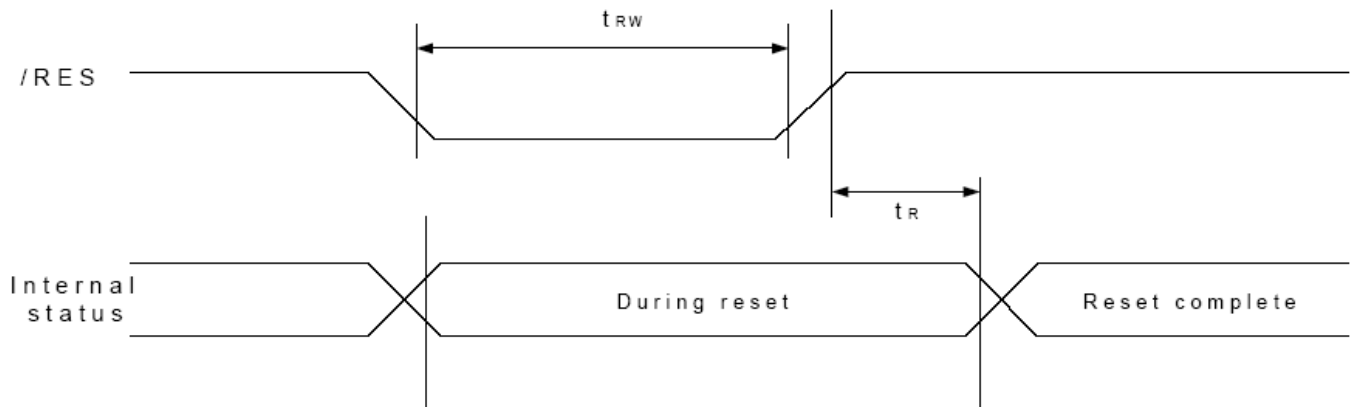

( $V_{DD} = 3.3V$ ,  $T_a = -40$  to  $85^\circ C$ )

Item	Signal	Symbol	Condition	Rating			Units
				Min	Typ	Max	
Reset time	-	$t_R$		-	-	0.5	$\mu s$
Reset "L" pulse width	RES	$t_{RW}$		0.5	-	-	$\mu s$

( $V_{DD} = 2.7V$ ,  $T_a = -40$  to  $85^\circ C$ )

Item	Signal	Symbol	Condition	Rating			Units
				Min	Typ	Max	
Reset time	-	$t_R$		-	-	1	$\mu s$
Reset "L" pulse width	RES	$t_{RW}$		1	-	-	$\mu s$

## 10. Display Command

Command	Command Code											Function
	A0	$\overline{RD}$ (E)	$\overline{WR}$ (R/W)	D7	D6	D5	D4	D3	D2	D2	D0	
(1) Display ON/OFF	0	1	0	1	0	1	0	1	1	1	0	LCD display ON/OFF 0:OFF, 1:ON
(2) Display start line set	0	1	0	0	1	Display start address					1	Sets the display RAM display start line address
(3) Page address set	0	1	0	1	0	1	1	Page address				Sets the display RAM page address
(4) Column address set upper bit	0	1	0	0	0	0	1	Most significant column address				Sets the most significant 4 bits of the display RAM column address.
Column address set lower bit	0	1	0	0	0	0	0	Least significant column address				Sets the least significant 4 bits of the display RAM column address.
(5) Status read	0	0	1	Status				0	0	0	0	Reads the status data
(6) Display data write	1	1	0	Write data							Writes to the display RAM	
(7) Display data read	1	0	1	Read data							Reads from the display RAM	
(8) ADC select	0	1	0	1	0	1	0	0	0	0	0	Sets the display RAM address SEG output correspondence 0: normal, 1: reverse
(9) Display normal/ reverse	0	1	0	1	0	1	0	0	1	1	0	Sets the LCD display RAM normal/reverse 0: normal, 1: reverse
(10) Display all points ON/OFF	0	1	0	1	0	1	0	0	1	0	0	Display all points 0: normal display, 1: all points ON
(11) LCD bias set	0	1	0	1	0	1	0	0	0	1	0	Sets the LCD drive voltage bias ratio 0: 1/9, 1:1/7
(12) Read/modify/write	0	1	0	1	1	1	0	0	0	0	0	Column address increment At write: +1 At read: 0
(13) End	0	1	0	1	1	1	0	1	1	1	0	Clear read/modify/write

(14) Reset	0	1	0	1	1	1	0	0	0	1	0	Internal reset	
(15) Common output mode select	0	1	0	1	1	0	0	0	*	*	*	Select COM output scan direction 0: normal direction, 1: reverse direction	
							1						
(16) Power control set	0	1	0	0	0	1	0	1	Operating mode				Select internal power supply operating mode
(17) V5 voltage regulator internal resistor ratio set	0	1	0	0	0	1	0	0	Resistor ratio				Select internal resistor ratio (Rb/Ra) mode
(18) Electronic volume mode set	0	1	0	1	0	0	0	0	0	0	1		
Electronic volume register set	0	1	0	*	*	Electronic volume value						Set the V5 output voltage electronic volume register.	
(19) Static indicator ON/OFF	0	1	0	1	0	1	0	1	1	0	0	0: OFF 1: ON	
											1		
Static indicator register set	1	0	1	*	*	*	*	*	*	*	Mode	Set the flashing mode	
(20) Power saver											Display OFF and display all points ON compound command		
(21) NOP	0	1	0	1	1	1	0	0	0	1	1	Command for non-operation	
(22) Test	0	1	0	1	1	1	1	*	*	*	*	Command for IC test. Do not use this command	

(Note) \*: disabled data

# 11. Reliability

## Content of Reliability Test (wide temperature, -20°C~70°C)

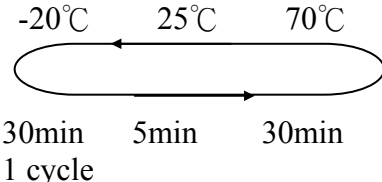
Environmental Test			
Test Item	Content of Test	Test Condition	Note
High Temperature storage	Endurance test applying the high storage temperature for a long time.	80°C 200hrs	2
Low Temperature storage	Endurance test applying the high storage temperature for a long time.	-30°C 200hrs	1,2
High Temperature Operation	Endurance test applying the electric stress (Voltage & Current) and the thermal stress to the element for a long time.	70°C 200hrs	—
Low Temperature Operation	Endurance test applying the electric stress under low temperature for a long time.	-20°C 200hrs	1
High Temperature/ Humidity Operation	The module should be allowed to stand at 60 °C, 90%RH max For 96hrs under no-load condition excluding the polarizer, Then taking it out and drying it at normal temperature.	60°C, 90%RH 96hrs	1,2
Thermal shock resistance	The sample should be allowed stand the following 10 cycles of operation  30min    5min    30min 1 cycle	-20°C/70°C 10 cycles	—
Vibration test	Endurance test applying the vibration during transportation and using.	Total fixed amplitude : 1.5mm Vibration Frequency : 10~55Hz One cycle 60 seconds to 3 directions of X,Y,Z for Each 15 minutes	3
Static electricity test	Endurance test applying the electric stress to the terminal.	VS=800V, RS=1.5kΩ CS=100pF 1 time	—

**Note1: No dew condensation to be observed.**

**Note2: The function test shall be conducted after 4 hours storage at the normal Temperature and humidity after remove from the test chamber.**

**Note3: Vibration test will be conducted to the product itself without putting it in a container.**

## 12.Backlight Information

### Specification

PARAMETER	SYMBOL	MIN	TYP	MAX	UNIT	TEST CONDITION
Supply Current	I <sub>LED</sub>	43.2	48	75	mA	V=3.5V
Supply Voltage	V	3.4	3.5	3.6	V	
Reverse Voltage	V <sub>R</sub>	—	—	5	V	—
Luminous Intensity	I <sub>V</sub>	456.2	570	—	CD/M <sup>2</sup>	I <sub>LED</sub> =48mA
LED Life Time	—	—	50K	—	Hr.	I <sub>LED</sub> ≤ 48mA
Color	White					

**Note:** The LED of B/L is drive by current only ; driving voltage is only for reference  
To make driving current in safety area (waste current between minimum and maximum).

**Note1 :**50K hours is only an estimate for reference.

# 13. Inspection specification

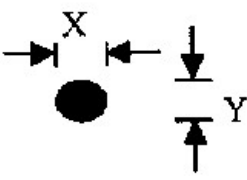
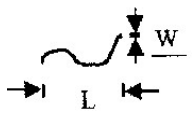
NO	Item	Criterion	AQL												
01	Electrical Testing	1.1 Missing vertical, horizontal segment, segment contrast defect. 1.2 Missing character , dot or icon. 1.3 Display malfunction. 1.4 No function or no display. 1.5 Current consumption exceeds product specifications. 1.6 LCD viewing angle defect. 1.7 Mixed product types. 1.8 Contrast defect.	0.65												
02	Black or white spots on LCD (display only)	2.1 White and black spots on display $\leq 0.25\text{mm}$ , no more than three white or black spots present. 2.2 Densely spaced: No more than two spots or lines within 3mm	2.5												
03	LCD black spots, white spots, contamination (non-display)	3.1 Round type : As following drawing $\Phi = (x + y) / 2$  <table border="1" data-bbox="874 1048 1353 1294"> <thead> <tr> <th>SIZE</th> <th>Acceptable Q TY</th> </tr> </thead> <tbody> <tr> <td><math>\Phi \leq 0.10</math></td> <td>Accept no dense</td> </tr> <tr> <td><math>0.10 &lt; \Phi \leq 0.20</math></td> <td>2</td> </tr> <tr> <td><math>0.20 &lt; \Phi \leq 0.25</math></td> <td>1</td> </tr> <tr> <td><math>0.25 &lt; \Phi</math></td> <td>0</td> </tr> </tbody> </table>	SIZE	Acceptable Q TY	$\Phi \leq 0.10$	Accept no dense	$0.10 < \Phi \leq 0.20$	2	$0.20 < \Phi \leq 0.25$	1	$0.25 < \Phi$	0	2.5		
		SIZE	Acceptable Q TY												
$\Phi \leq 0.10$	Accept no dense														
$0.10 < \Phi \leq 0.20$	2														
$0.20 < \Phi \leq 0.25$	1														
$0.25 < \Phi$	0														
3.2 Line type : (As following drawing)  <table border="1" data-bbox="710 1400 1353 1646"> <thead> <tr> <th>Length</th> <th>Width</th> <th>Acceptable Q TY</th> </tr> </thead> <tbody> <tr> <td>---</td> <td><math>W \leq 0.02</math></td> <td>Accept no dense</td> </tr> <tr> <td><math>L \leq 3.0</math></td> <td><math>0.02 &lt; W \leq 0.03</math></td> <td rowspan="2">2</td> </tr> <tr> <td><math>L \leq 2.5</math></td> <td><math>0.03 &lt; W \leq 0.05</math></td> </tr> <tr> <td>---</td> <td><math>0.05 &lt; W</math></td> <td>As round type</td> </tr> </tbody> </table>	Length	Width	Acceptable Q TY	---	$W \leq 0.02$	Accept no dense	$L \leq 3.0$	$0.02 < W \leq 0.03$	2	$L \leq 2.5$	$0.03 < W \leq 0.05$	---	$0.05 < W$	As round type	2.5
Length	Width	Acceptable Q TY													
---	$W \leq 0.02$	Accept no dense													
$L \leq 3.0$	$0.02 < W \leq 0.03$	2													
$L \leq 2.5$	$0.03 < W \leq 0.05$														
---	$0.05 < W$	As round type													
04	Polarizer bubbles	If bubbles are visible, judge using black spot specifications, not easy to find, must check in specify direction. <table border="1" data-bbox="842 1702 1353 1993"> <thead> <tr> <th>Size <math>\Phi</math></th> <th>Acceptable Q TY</th> </tr> </thead> <tbody> <tr> <td><math>\Phi \leq 0.20</math></td> <td>Accept no dense</td> </tr> <tr> <td><math>0.20 &lt; \Phi \leq 0.50</math></td> <td>3</td> </tr> <tr> <td><math>0.50 &lt; \Phi \leq 1.00</math></td> <td>2</td> </tr> <tr> <td><math>1.00 &lt; \Phi</math></td> <td>0</td> </tr> <tr> <td>Total Q TY</td> <td>3</td> </tr> </tbody> </table>	Size $\Phi$	Acceptable Q TY	$\Phi \leq 0.20$	Accept no dense	$0.20 < \Phi \leq 0.50$	3	$0.50 < \Phi \leq 1.00$	2	$1.00 < \Phi$	0	Total Q TY	3	2.5
Size $\Phi$	Acceptable Q TY														
$\Phi \leq 0.20$	Accept no dense														
$0.20 < \Phi \leq 0.50$	3														
$0.50 < \Phi \leq 1.00$	2														
$1.00 < \Phi$	0														
Total Q TY	3														

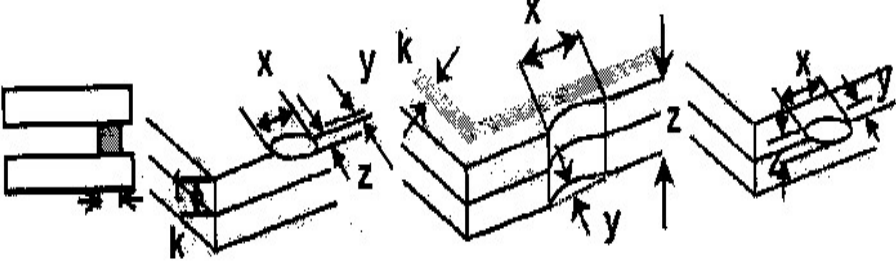
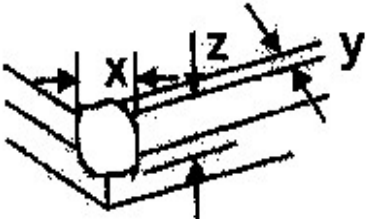
NO	Item	Criterion	AQL																		
05	Scratches	Follow NO.3 LCD black spots, white spots, contamination																			
06	Chipped glass	<p>Symbols Define:  x: Chip length      y: Chip width      z: Chip thickness  k: Seal width      t: Glass thickness      a: LCD side length  L: Electrode pad length:</p> <p>6.1 General glass chip :  6.1.1 Chip on panel surface and crack between panels:</p>  <table border="1" data-bbox="422 945 1316 1137"> <thead> <tr> <th>z: Chip thickness</th> <th>y: Chip width</th> <th>x: Chip length</th> </tr> </thead> <tbody> <tr> <td><math>Z \leq 1/2t</math></td> <td>Not over viewing area</td> <td><math>x \leq 1/8a</math></td> </tr> <tr> <td><math>1/2t &lt; z \leq 2t</math></td> <td>Not exceed 1/3k</td> <td><math>x \leq 1/8a</math></td> </tr> </tbody> </table> <p>⊙If there are 2 or more chips, x is total length of each chip.</p> <p>6.1.2 Corner crack:</p>  <table border="1" data-bbox="422 1534 1316 1727"> <thead> <tr> <th>z: Chip thickness</th> <th>y: Chip width</th> <th>x: Chip length</th> </tr> </thead> <tbody> <tr> <td><math>Z \leq 1/2t</math></td> <td>Not over viewing area</td> <td><math>x \leq 1/8a</math></td> </tr> <tr> <td><math>1/2t &lt; z \leq 2t</math></td> <td>Not exceed 1/3k</td> <td><math>x \leq 1/8a</math></td> </tr> </tbody> </table> <p>⊙If there are 2 or more chips, x is the total length of each chip.</p>	z: Chip thickness	y: Chip width	x: Chip length	$Z \leq 1/2t$	Not over viewing area	$x \leq 1/8a$	$1/2t < z \leq 2t$	Not exceed 1/3k	$x \leq 1/8a$	z: Chip thickness	y: Chip width	x: Chip length	$Z \leq 1/2t$	Not over viewing area	$x \leq 1/8a$	$1/2t < z \leq 2t$	Not exceed 1/3k	$x \leq 1/8a$	2.5
z: Chip thickness	y: Chip width	x: Chip length																			
$Z \leq 1/2t$	Not over viewing area	$x \leq 1/8a$																			
$1/2t < z \leq 2t$	Not exceed 1/3k	$x \leq 1/8a$																			
z: Chip thickness	y: Chip width	x: Chip length																			
$Z \leq 1/2t$	Not over viewing area	$x \leq 1/8a$																			
$1/2t < z \leq 2t$	Not exceed 1/3k	$x \leq 1/8a$																			

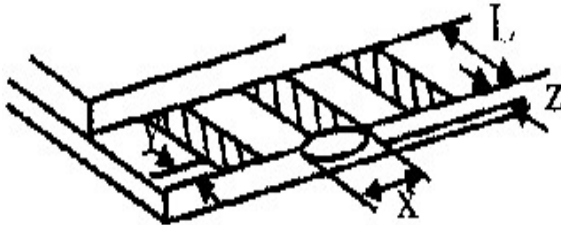
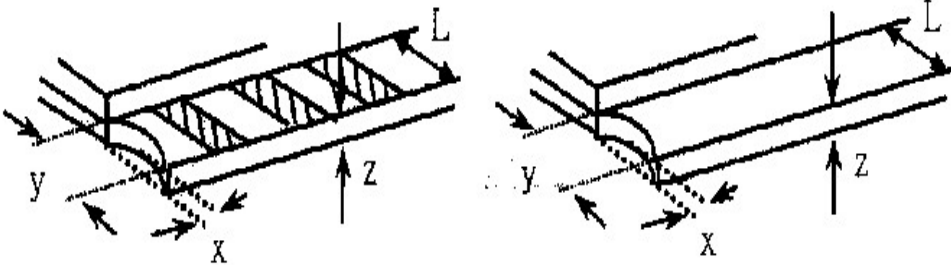
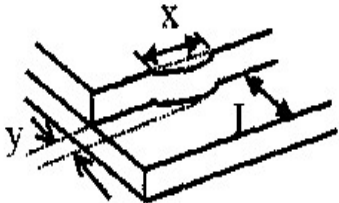
NO	Item	Criterion	AQL																
06	Glass crack	<p>Symbols :</p> <p>x: Chip length      y: Chip width      z: Chip thickness  k: Seal width      t: Glass thickness      a: LCD side length  L: Electrode pad length</p> <p>6.2 Protrusion over terminal :</p> <p>6.2.1 Chip on electrode pad :</p>  <table border="1" data-bbox="352 703 1265 790"> <tr> <td>y: Chip width</td> <td>x: Chip length</td> <td>z: Chip thickness</td> </tr> <tr> <td><math>y \leq 0.5\text{mm}</math></td> <td><math>x \leq 1/8a</math></td> <td><math>0 &lt; z \leq t</math></td> </tr> </table> <p>6.2.2 Non-conductive portion:</p>  <table border="1" data-bbox="426 1122 1265 1209"> <tr> <td>y: Chip width</td> <td>x: Chip length</td> <td>z: Chip thickness</td> </tr> <tr> <td><math>y \leq L</math></td> <td><math>x \leq 1/8a</math></td> <td><math>0 &lt; z \leq t</math></td> </tr> </table> <p>⊙ If the chipped area touches the ITO terminal, over 2/3 of the ITO must remain and be inspected according to electrode terminal specifications.  ⊙ If the product will be heat sealed by the customer, the alignment mark not be damaged.</p> <p>6.2.3 Substrate protuberance and internal crack.</p>  <table border="1" data-bbox="762 1435 1270 1518"> <tr> <td>y: width</td> <td>x: length</td> </tr> <tr> <td><math>y \leq 1/3L</math></td> <td><math>x \leq a</math></td> </tr> </table>	y: Chip width	x: Chip length	z: Chip thickness	$y \leq 0.5\text{mm}$	$x \leq 1/8a$	$0 < z \leq t$	y: Chip width	x: Chip length	z: Chip thickness	$y \leq L$	$x \leq 1/8a$	$0 < z \leq t$	y: width	x: length	$y \leq 1/3L$	$x \leq a$	2.5
y: Chip width	x: Chip length	z: Chip thickness																	
$y \leq 0.5\text{mm}$	$x \leq 1/8a$	$0 < z \leq t$																	
y: Chip width	x: Chip length	z: Chip thickness																	
$y \leq L$	$x \leq 1/8a$	$0 < z \leq t$																	
y: width	x: length																		
$y \leq 1/3L$	$x \leq a$																		

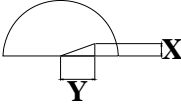
NO	Item	Criterion	AQL
07	Cracked glass	The LCD with extensive crack is not acceptable.	2.5
08	Backlight elements	8.1 Illumination source flickers when lit. 8.2 Spots or scratched that appear when lit must be judged. Using LCD spot, lines and contamination standards. 8.3 Backlight doesn't light or color wrong.	0.65 2.5 0.65
09	Bezel	9.1 Bezel may not have rust, be deformed or have fingerprints, stains or other contamination. 9.2 Bezel must comply with job specifications.	2.5 0.65
10	PCB 、 COB	10.1 COB seal may not have pinholes larger than 0.2mm or contamination. 10.2 COB seal surface may not have pinholes through to the IC. 10.3 The height of the COB should not exceed the height indicated in the assembly diagram. 10.4 There may not be more than 2mm of sealant outside the seal area on the PCB. And there should be no more than three places. 10.5 No oxidation or contamination PCB terminals. 10.6 Parts on PCB must be the same as on the production characteristic chart. There should be no wrong parts, missing parts or excess parts. 10.7 The jumper on the PCB should conform to the product characteristic chart. 10.8 If solder gets on bezel tab pads, LED pad, zebra pad or screw hold pad, make sure it is smoothed down. 10.9 The Scraping testing standard for Copper Coating of PCB  <b><math>X * Y \leq 2\text{mm}^2</math></b>	2.5 2.5 0.65 2.5 2.5 0.65 2.5 2.5
11	Soldering	11.1 No un-melted solder paste may be present on the PCB. 11.2 No cold solder joints, missing solder connections, oxidation or icicle. 11.3 No residue or solder balls on PCB. 11.4 No short circuits in components on PCB.	2.5 2.5 2.5 0.65

NO	Item	Criterion	AQL
12	General appearance	12.1 No oxidation, contamination, curves or, bends on interface Pin (OLB) of TCP.	2.5
		12.2 No cracks on interface pin (OLB) of TCP.	0.65
		12.3 No contamination, solder residue or solder balls on product.	2.5
		12.4 The IC on the TCP may not be damaged, circuits.	2.5
		12.5 The uppermost edge of the protective strip on the interface pin must be present or look as if it cause the interface pin to sever.	2.5
		12.6 The residual rosin or tin oil of soldering (component or chip component) is not burned into brown or black color.	2.5
		12.7 Sealant on top of the ITO circuit has not hardened.	0.65
		12.8 Pin type must match type in specification sheet.	0.65
		12.9 LCD pin loose or missing pins.	0.65
		12.10 Product packaging must the same as specified on packaging specification sheet.	0.65
		12.11 Product dimension and structure must conform to product specification sheet.	

# 14. Material List of Components for RoHs

1. WINSTAR Display Co., Ltd hereby declares that all of or part of products (with the mark “#”in code), including, but not limited to, the LCM, accessories or packages, manufactured and/or delivered to your company (including your subsidiaries and affiliated company) directly or indirectly by our company (including our subsidiaries or affiliated companies) do not intentionally contain any of the substances listed in all applicable EU directives and regulations, including the following substances.

Exhibit A : The Harmful Material List

Material	(Cd)	(Pb)	(Hg)	(Cr6+)	PBBs	PBDEs
Limited Value	100 ppm	1000 ppm	1000 ppm	1000 ppm	1000 ppm	1000 ppm
Above limited value is set up according to RoHS.						

2.Process for RoHS requirement :

(1) Use the Sn/Ag/Cu soldering surface ; the surface of Pb-free solder is rougher than we used before.

(2) Heat-resistance temp. :

Reflow : 250□,30 seconds Max. ;

Connector soldering wave or hand soldering : 320□, 10 seconds max.

(3) Temp. curve of reflow, max. Temp. : 235±5□ ;

Recommended customer’s soldering temp. of connector : 280□, 3 seconds.



**1、Panel Specification :**

- 1. Panel Type :  Pass  NG , \_\_\_\_\_
- 2. View Direction :  Pass  NG , \_\_\_\_\_
- 3. Numbers of Dots :  Pass  NG , \_\_\_\_\_
- 4. View Area :  Pass  NG , \_\_\_\_\_
- 5. Active Area :  Pass  NG , \_\_\_\_\_
- 6. Operating Temperature :  Pass  NG , \_\_\_\_\_
- 7. Storage Temperature :  Pass  NG , \_\_\_\_\_
- 8. Others : \_\_\_\_\_

**2、Mechanical Specification :**

- 1. PCB Size :  Pass  NG , \_\_\_\_\_
- 2. Frame Size :  Pass  NG , \_\_\_\_\_
- 3. Material of Frame :  Pass  NG , \_\_\_\_\_
- 4. Connector Position :  Pass  NG , \_\_\_\_\_
- 5. Fix Hole Position : A  Pass  NG , \_\_\_\_\_
- 6. Backlight Position :  Pass  NG , \_\_\_\_\_
- 7. Thickness of PCB :  Pass  NG , \_\_\_\_\_
- 8. Height of Frame to PCB :  Pass  NG , \_\_\_\_\_
- 9. Height of Module :  Pass  NG , \_\_\_\_\_
- 10. Others :  Pass  NG , \_\_\_\_\_

**3、Relative Hole Size :**

- 1. Pitch of Connector :  Pass  NG , \_\_\_\_\_
- 2. Hole size of Connector :  Pass  NG , \_\_\_\_\_
- 3. Mounting Hole size :  Pass  NG , \_\_\_\_\_
- 4. Mounting Hole Type :  Pass  NG , \_\_\_\_\_
- 5. Others :  Pass  NG , \_\_\_\_\_

**4、Backlight Specification :**

- 1. B/L Type :  Pass  NG , \_\_\_\_\_
- 2. B/L Color :  Pass  NG , \_\_\_\_\_
- 3. B/L Driving Voltage (Reference for LED Type) :  Pass  NG , \_\_\_\_\_
- 4. B/L Driving Current :  Pass  NG , \_\_\_\_\_
- 5. Brightness of B/L :  Pass  NG , \_\_\_\_\_
- 6. B/L Solder Method :  Pass  NG , \_\_\_\_\_
- 7. Others :  Pass  NG , \_\_\_\_\_

>> **Go to page 2** <<



Module Number : \_\_\_\_\_

5、Electronic Characteristics of Module :

- 1. Input Voltage :  Pass  NG , \_\_\_\_\_
- 2. Supply Current :  Pass  NG , \_\_\_\_\_
- 3. Driving Voltage for LCD :  Pass  NG , \_\_\_\_\_
- 4. Contrast for LCD :  Pass  NG , \_\_\_\_\_
- 5. B/L Driving Method :  Pass  NG , \_\_\_\_\_
- 6. Negative Voltage Output :  Pass  NG , \_\_\_\_\_
- 7. Interface Function :  Pass  NG , \_\_\_\_\_
- 8. LCD Uniformity :  Pass  NG , \_\_\_\_\_
- 9. ESD test :  Pass  NG , \_\_\_\_\_
- 10. Others :  Pass  NG , \_\_\_\_\_

6、Summary :

Sales signature : \_\_\_\_\_

Customer Signature : \_\_\_\_\_

Date :    /    /