



Winstar Display Co., LTD

華凌光電股份有限公司

WEB: <http://www.winstar.com.tw>

E-mail: winstar@winstar.com.tw



SPECIFICATION

CUSTOMER : _____

MODULE NO.: WF70QTIFGDBCZ#

<p style="text-align: center;">APPROVED BY:</p> <p>(FOR CUSTOMER USE ONLY)</p>	<p>PCB VERSION: _____</p> <p>DATA: _____</p>
---	--

SALES BY	APPROVED BY	CHECKED BY	PREPARED BY
			葉虹蘭
ISSUED DATE: 2016/11/01			

RECORDS OF REVISION

DOC. FIRST ISSUE

VERSION	DATE	REVISED PAGE NO.	SUMMARY
0	2015/06/03		First issue
A	2016/01/21		Modify Static electricity test
B	2016/05/19		Modify touchpanel.
C	2016/08/10		Modify Vibration test.
D	2016/10/05		Modify Summary
E	2016/11/01		Add Aspect Ratio
			Modify Touch Panel Information.

Contents

- 1.Module Classification Information
- 2.Summary
- 3.General Specification
- 4.Absolute Maximum Ratings
- 5.Electrical Characteristics
- 6.DC Characteristics
- 7.Interface Timing Characteristics
- 8.Optical Characteristics
- 9.Interface
- 10.Block Diagram
- 11.Reliability
- 12.Touch Panel Information
- 13.Contour Drawing
- 14.Initial Code For Reference

1.Module Classification Information

W F 70 Q T I F G D B C Z #
 ① ② ③ ④ ⑤ ⑥ ⑦ ⑧ ⑨ ⑩ ⑪ ⑫ ⑬

①	Brand : WINSTAR DISPLAY CORPORATION						
②	Display Type : F→TFT Type, J→Custom TFT						
③	Display Size : 7.0" TFT						
④	Model serials no.						
⑤	Backlight Type :	F→CCFL, White S→LED, High Light White			T→LED, White		
⑥	LCD Polarize Type/ Temperature range/ Gray Scale Inversion Direction	C→Transmissive, N. T, 6:00 ; I→Transmissive, W. T, 6:00 F→Transmissive, N.T,12:00 ; L→Transmissive, W.T,12:00 N→Transmissive, Super W.T, 6:00 Q→Transmissive, Super W.T, 12:00 X→Transmissive, W.T, VA TFT V→Transmissive, Super W.T, VA TFT R→Transmissive, Super W.T, O-TFT Z→Transmissive, W.T, O-TFT A→Transmissive, N.T, IPS TFT Y→Transmissive, W.T, IPS TFT					
⑦	A : TFT LCD B : TFT+FR+CONTROL BOARD C : TFT+FR+A/D BOARD D : TFT+FR+A/D BOARD+CONTROL BOARD E : TFT+FR+POWER BOARD F : TFT+CONTROL BOARD			G : TFT+FR H : TFT+D/V BOARD I : TFT+FR+D/V BOARD J : TFT+POWER BD			
⑧	Resolution:						
	A: 128160	B:320234	C:320240	D:480234	E:480272	F: 640480	G: 800480
	H:1024600	I:320480	J:240320	K:800600	L:240400	M :1024768	P :1280800
	S:480128	T:800320					
⑨	D: Digital L : LVDS						
⑩	Interface : N : without control board A : 8Bit B : 16Bit						
⑪	TS : N : Without TS T : resistive touch panel C : capacitive touch panel (G-F-F) G : capacitive touch panel(G-G)						
⑫	Version						
⑬	Special Code	#:Fit in with ROHS directive regulations					

2.Summary

TFT 7.0" is a TN transmissive type color active matrix TFT liquid crystal display that use amorphous silicon TFT as switching devices. This module is composed of a TFT_LCD module, It is usually designed for industrial application and this module follows RoHs.

3.General Specifications

Item	Dimension	Unit
Size	7.0	inch
Dot Matrix	800 x RGB x 480(TFT)	dots
Module dimension	165.0(W) x 100.0(H) x 13.46(D)	mm
Active area	154.08 x 85.92	mm
Dot pitch	0.0642 x 0.179	mm
LCD type	TFT, Normally White, Transmissive	
View Direction	12 o'clock	
Gray Scale Inversion Direction	6 o'clock	
Aspect Ratio	16:9	
Backlight Type	LED,Normally White	
Controller IC	SSD1963	
Interface	Digital 8080 family MPU	
CTP FW Version	10	
With /Without TP	With CTP	
Surface	Glare	

*Color tone slight changed by temperature and driving voltage.

4. Absolute Maximum Ratings

Item	Symbol	Min	Typ	Max	Unit
Operating Temperature	TOP	-20	—	+70	°C
Storage Temperature	TST	-30	—	+80	°C

Note: Device is subject to be damaged permanently if stresses beyond those absolute maximum ratings listed above

1. Temp. $\leq 60^{\circ}\text{C}$, 85% RH MAX. Temp. $> 60^{\circ}\text{C}$, Absolute humidity shall be less than 85% RH at 60°C

5. Electrical Characteristics

5.1. Operating conditions: (CON2.Pin1=GND, Pin2=VDD)

Item	Symbol	Condition	Min	Typ	Max	Unit	Remark
Supply Voltage For LCM	VDD	—	3.0	3.1	3.3	V	—
Supply Current For LCM	IDD	—	—	310	460	mA	Note1

Note 1 : This value is test for VDD=3.3V , Ta=25°C only

5.2. Backlight driving conditions (CON2.Pin33,34=VLED-, Pin35,36=VLED+)

Parameter	Symbol	Min.	Typ.	Max.	Unit	Remark
Operation Current For LED Driver	VLED=5V	400	—	600	mA	Note 1,2
Power Consumption	VLED=5V	2000	—	3000	mW	Note 1,2
Supply Voltage For LED Driver	VLED+	—	5	—	V	—
LED Life Time	—	20,000	—	—	Hr	Note 2,3,4

Note 1 : Base on VLED= 5V for the back light driver IC specification

Note 2 : Ta = 25 °C

Note 3 : Brightness to be decreased to 50% of the initial value

Note 4 : The single LED lamp case

6.DC CHARATERISTICS

Parameter	Symbol	Rating			Unit	Condition
		Min	Typ	Max		
Low level input voltage	V_{IL}	0	-	0.3VDD	V	
High level input voltage	V_{IH}	0.7VDD	-	VDD	V	

7. Interface timing

7.1. 8080 Mode

The 8080 mode MCU interface consist of CS#, D/C#, RD#, WR#, Data Bus. This interface use WR# to define a write cycle and RD# for read cycle. If the WR# goes low when the CS# signal is low, the data or command will be latched into the system at the rising edge of WR#. Similarly, the read cycle will start when RD# goes low and end at the rising edge of RD#.

7.2. 8080 Mode Write Cycle

Symbol	Parameter	Min	Typ	Max	Unit
fMCLK	System Clock Frequency	1	-	110	MHz
tMCLK	System Clock Period	1/fMCLK	-	-	ns
tPWCSH	Control Pulse High Width Write	13	1.5* tMCLK	-	ns
	Read	30	3.5* tMCLK	-	ns
tPWCSL	Control Pulse Low Width Write (next write cycle)	13	1.5* tMCLK	-	ns
	Write (next read cycle)	80	9* tMCLK	-	
	Read	80	9* tMCLK	-	
tAS	Address Setup Time	1	-	-	ns
tAH	Address Hold Time	2	-	-	ns
tDSW	Write Data Setup Time	4	-	-	ns
tDHW	Write Data Hold Time	1	-	-	ns
tPWLW	Write Low Time	12	-	-	ns
tDHR	Read Data Hold Time	1	-	-	ns
tACC	Access Time	32	-	-	ns
tPWLR	Read Low Time	36	-	-	ns
tR	Rise Time	-	-	0.5	ns
tF	Fall Time	-	-	0.5	ns
tCS	Chip select setup time	2	-	-	ns
tCSH	Chip select hold time to read signal	3	-	-	ns

7.3. Parallel 8080-series Interface Timing Diagram(Write Cycle)

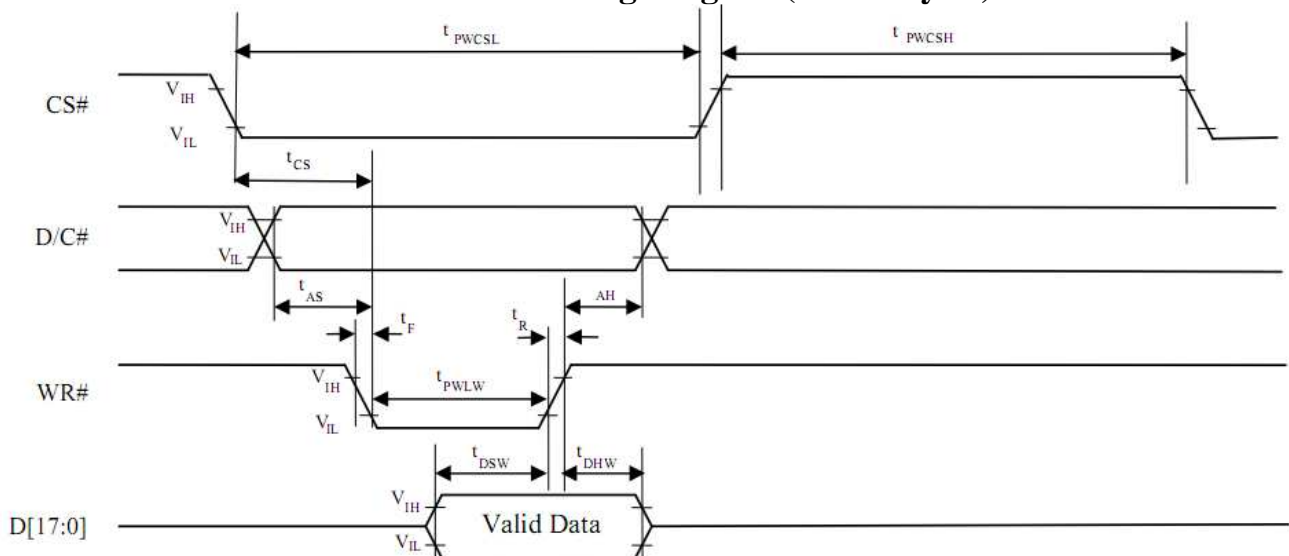

7.4. Parallel 8080-series Interface Timing Diagram(Read Cycle)

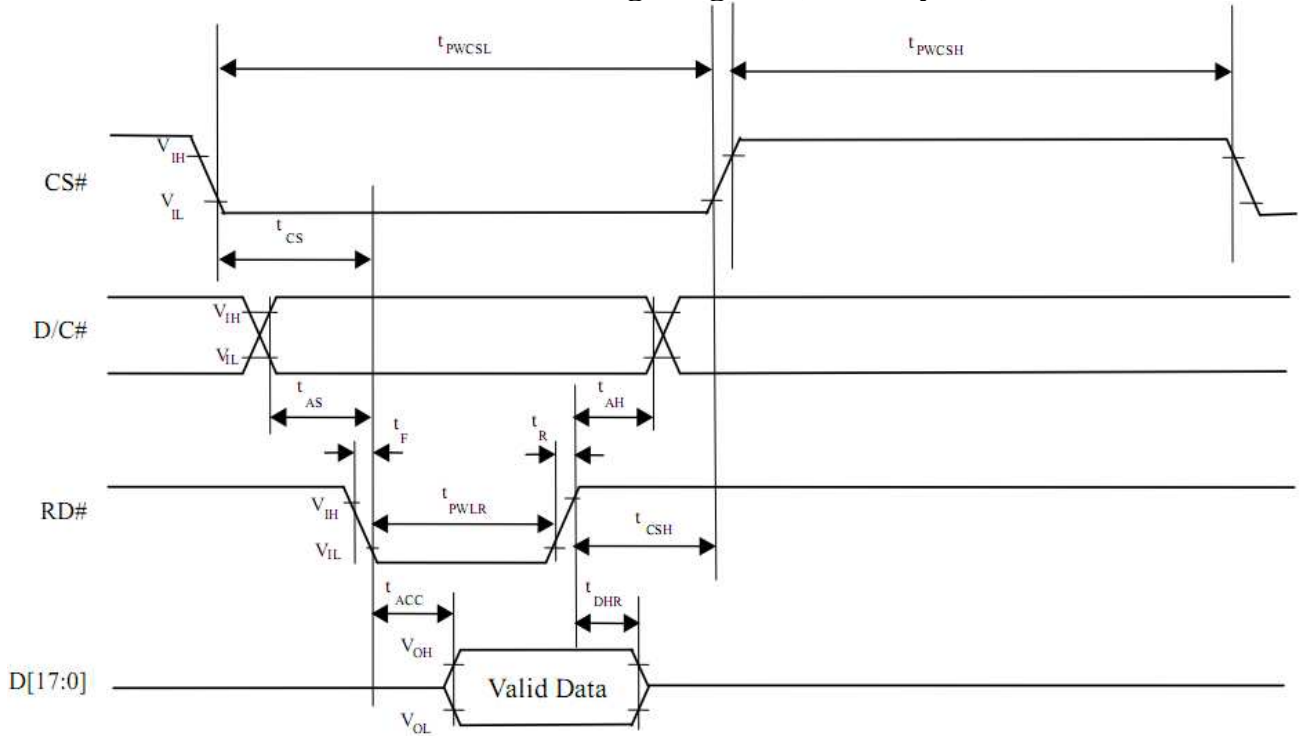

7.5. Pixel Data Format

Interface	Cycle	D[15]	D[14]	D[13]	D[12]	D[11]	D[10]	D[9]	D[8]	D[7]	D[6]	D[5]	D[4]	D[3]	D[2]	D[1]	D[0]
16 bits (565 format)	1 st	R5	R4	R3	R2	R1	G5	G4	G3	G2	G1	G0	B5	B4	B3	B2	B1
16 bits	1 st	R7	R6	R5	R4	R3	R2	R1	R0	G7	G6	G5	G4	G3	G2	G1	G0
	2 nd	B7	B6	B5	B4	B3	B2	B1	B0	R7	R6	R5	R4	R3	R2	R1	R0
	3 rd	G7	G6	G5	G4	G3	G2	G1	G0	B7	B6	B5	B4	B3	B2	B1	B0
8 bits	1 st									R7	R6	R5	R4	R3	R2	R1	R0
	2 nd									G7	G6	G5	G4	G3	G2	G1	G0
	3 rd									B7	B6	B5	B4	B3	B2	B1	B0

8. Optical Characteristics

Item	Symbol	Condition.	Min	Typ.	Max.	Unit	Remark	
Response time	T_r	$\theta=0^\circ, \Phi=0^\circ$	-	10	20	.ms	Note 3	
	T_f		-	15	30	.ms		
Contrast ratio	CR	At optimized viewing angle	400	500	-	-	Note 4	
Color Chromaticity	White	$\theta=0^\circ, \Phi=0$	W_x	0.26	0.31	0.36	-	Note 2,5,6
			W_y	0.28	0.33	0.38	-	
Viewing angle (Gray Scale Inversion Direction)	Hor.	$CR \geq 10$	Θ_R	60	70	-	Deg.	Note 1
			Θ_L	60	70	-		
	Ver.		Φ_T	40	50	-		
			Φ_B	60	70	-		
Brightness	-	-	280	320	-	cd/m ²	Center of display	

Ta=25±2°C, VLED / ILED= 5V / 400mA

Note 1: Definition of viewing angle range

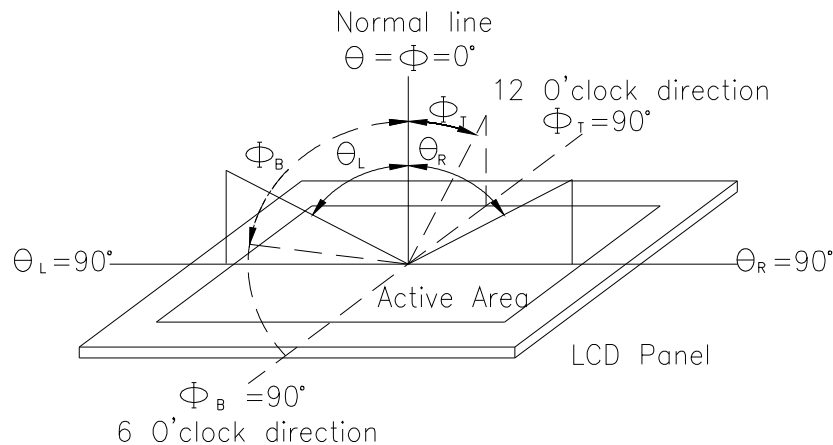

Fig. 8.1. Definition of viewing angle

Note 2: Test equipment setup:

After stabilizing and leaving the panel alone at a driven temperature for 10 minutes, the measurement should be executed. Measurement should be executed in a stable, windless, and dark room. Optical specifications are measured by Topcon BM-7orBM-5 luminance meter 1.0° field of view at a distance of 50cm and normal direction.

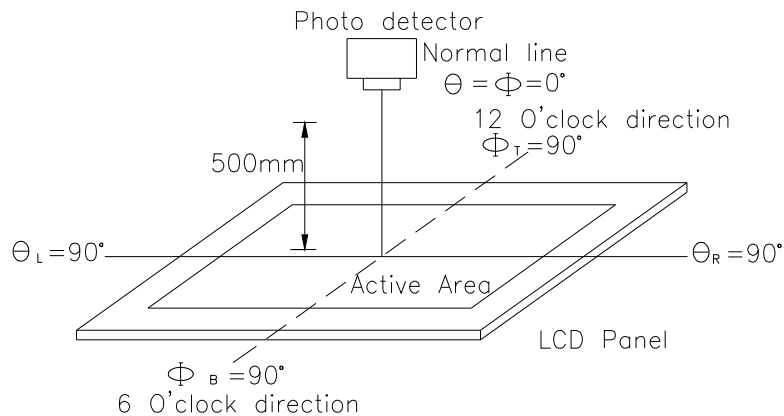
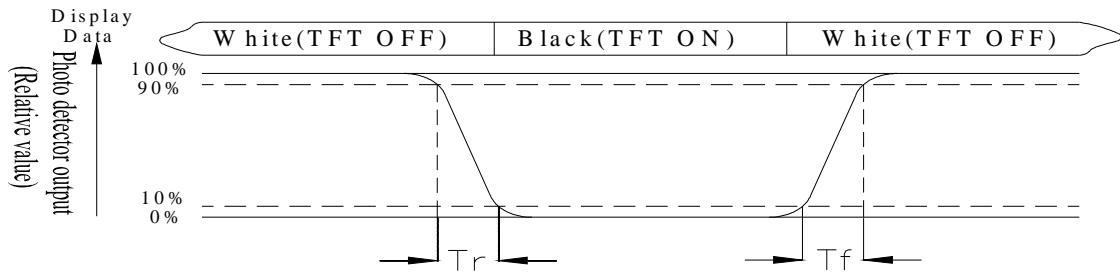

Fig. 8.2. Optical measurement system setup

Note 3: Definition of Response time:

The response time is defined as the LCD optical switching time interval between “White” state and “Black” state. Rise time, T_r , is the time between photo detector output intensity changed from 90% to 10%. And fall time, T_f , is the time between photo detector output intensity changed from 10% to 90%.



Note 4: Definition of contrast ratio:

The contrast ratio is defined as the following expression.

$$\text{Contrast ratio (CR)} = \frac{\text{Luminance measured when LCD on the "White" state}}{\text{Luminance measured when LCD on the "Black" state}}$$

Note 5: White $V_i = V_{i50} \pm 1.5V$

Black $V_i = V_{i50} \pm 2.0V$

“±” means that the analog input signal swings in phase with VCOM signal.

“±” means that the analog input signal swings out of phase with VCOM signal.

The 100% transmission is defined as the transmission of LCD panel when all the input terminals of module are electrically opened.

Note 6: Definition of color chromaticity (CIE 1931)

Color coordinates measured at the center point of LCD

Note 7: Measured at the center area of the panel when all the input terminals of LCD panel are electrically opened.

9.Interface

9.1. LCM PIN Definition (CON2)

Pin	Symbol	Function	Remark
1	GND	System ground pin of the IC . Connect to system ground.	
2	VDD	Power Supply : +3.3V	
3	BLE	Backlight control signal , H: On \ L: Off	
4	D/C	Data/Command select	
5	WR	Write strobe signal	
6	RD	Read strobe signal	
7	DB0	Data bus	
8	DB1	Data bus	
9	DB2	Data bus	
10	DB3	Data bus	
11	DB4	Data bus	
12	DB5	Data bus	
13	DB6	Data bus	
14	DB7	Data bus	
15	DB8	Data bus (When select 8bits Mode, this pin is NC)	Note1
16	DB9	Data bus (When select 8bits Mode, this pin is NC)	Note1
17	DB10	Data bus (When select 8bits Mode, this pin is NC)	Note1
18	DB11	Data bus (When select 8bits Mode, this pin is NC)	Note1
19	DB12	Data bus (When select 8bits Mode, this pin is NC)	Note1
20	DB13	Data bus (When select 8bits Mode, this pin is NC)	Note1
21	DB14	Data bus (When select 8bits Mode, this pin is NC)	Note1
22	DB15	Data bus (When select 8bits Mode, this pin is NC)	Note1
23	NC	No connect	
24	CTP_INT	CTP_ External interrupt to the host	
25	CS	Chip select	
26	RST	Hardware reset	
27	L/R	Left / right selection; Default L/R=H	Note 2,3
28	U/D	Up/down selection; ; Default U/D=L	Note 2,3
29	CTP_SCL	CTP_ SPI Slave mode, chip select, active low / I2C clock input	
30	CTP_SDA	CTP_ SPI Slave mode, data input / I2C data input and output	
31	CTP_RST	CTP_ External Reset, Low is active	
32	CTP_WAKE	CTP_ External interrupt from the host	
33	VLED-	Power for LED Driver IC(GND)	
34	VLED-	Power for LED Driver IC(GND)	
35	VLED+	Power for LED Driver IC(+5V)	
36	VLED+	Power for LED Driver IC(+5V)	

Note1: When select 8bit mode, DB0~DB7 be used, DB8~DB15 no connect
When select 16bit mode, DB0~DB15 be used

Note 2: Selection of scanning mode

Setting of scan control input		Scanning direction
U/D	L/R	
GND	VDD	Up to down, left to right
VDD	GND	Down to up, right to left
GND	GND	Up to down, right to left
VDD	VDD	Down to up, left to right

Note 3: Definition of scanning direction. Refer to the figure as below:



U/D=L, L/R=H

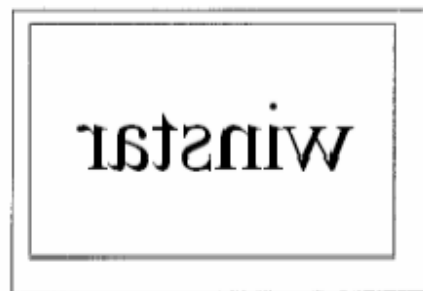

U/D=L, L/R=L

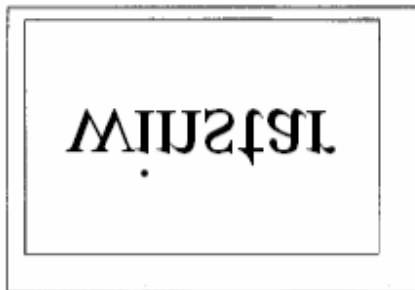

U/D=H, L/R=H

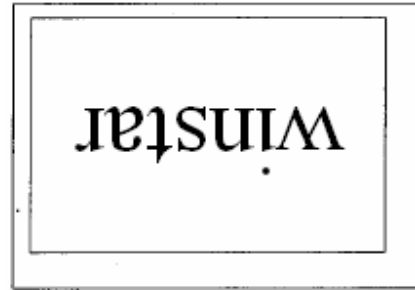

U/D=H, L/R=L

10. Block Diagram

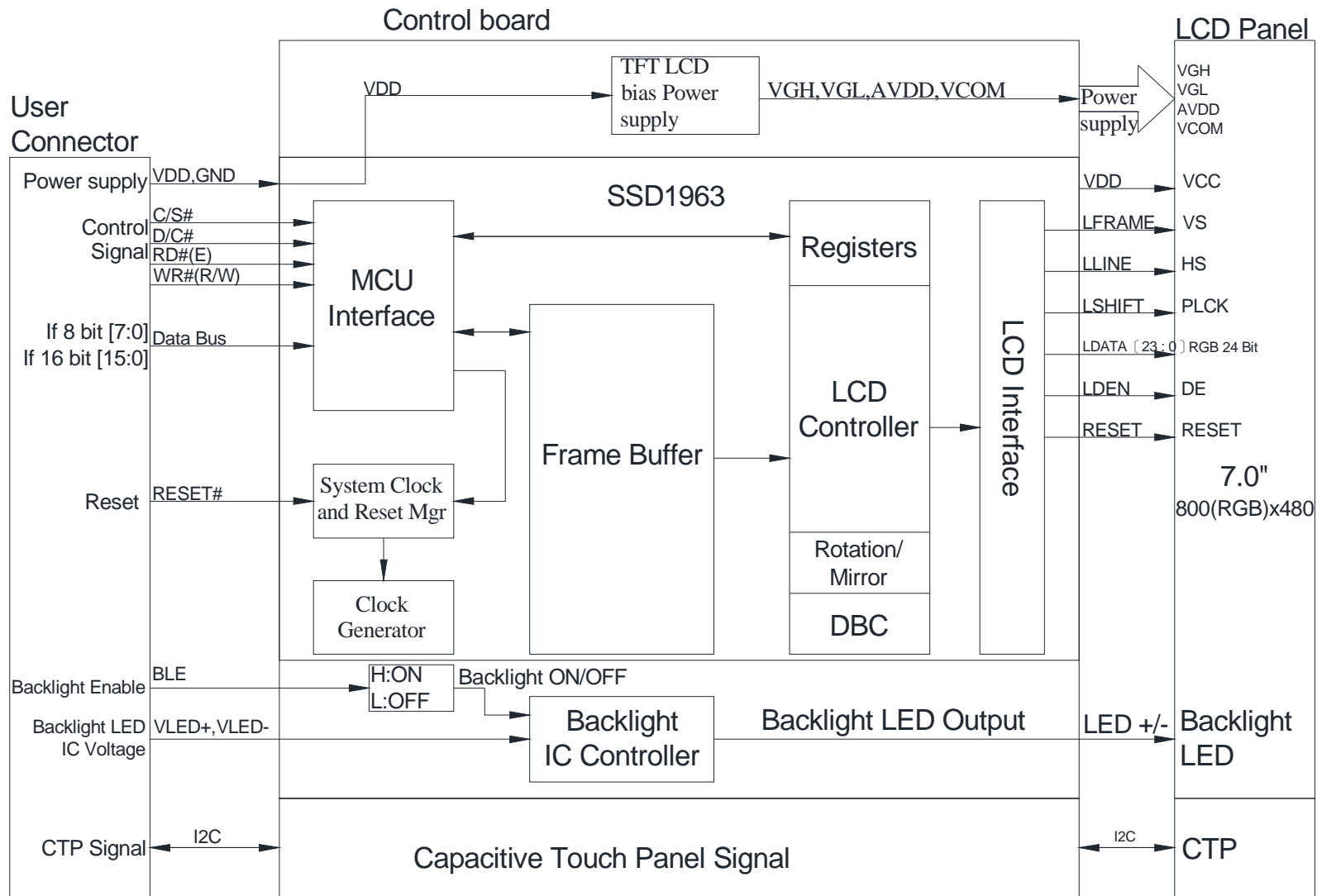

11. Reliability

Content of Reliability Test (Wide temperature, -20°C~70°C)

Environmental Test			
Test Item	Content of Test	Test Condition	Note
High Temperature storage	Endurance test applying the high storage temperature for a long time.	80°C 96hrs	2
Low Temperature storage	Endurance test applying the low storage temperature for a long time.	-30°C 96hrs	1,2
High Temperature Operation	Endurance test applying the electric stress (Voltage & Current) and the thermal stress to the element for a long time.	70°C 96hrs	—
Low Temperature Operation	Endurance test applying the electric stress under low temperature for a long time.	-20°C 96hrs	1
High Temperature/ Humidity Operation	The module should be allowed to stand at 60°C,85%RH max	60°C,85%RH 96hrs	1,2
Thermal shock resistance	The sample should be allowed stand the following 10 cycles of operation <div style="text-align: center;"> <p style="margin: 0;">-20°C 25°C 60°C</p> <p style="margin: 0;">30min 5min 30min</p> <p style="margin: 0;">1 cycle</p> </div>	-20°C/60°C 10 cycles	—
Vibration test	Endurance test applying the vibration during transportation and using.	Total fixed amplitude : 1.5mm Vibration Frequency : 10~55Hz One cycle 60 seconds to 3 directions of X,Y,Z for Each 15 minutes	3
Static electricity test	Endurance test applying the electric stress to the terminal.	VS=±600V(contact), ±800v(air), RS=330Ω CS=150pF 10 times	—

Note1: No dew condensation to be observed.

Note2: The function test shall be conducted after 4 hours storage at the normal Temperature and humidity after remove from the test chamber.

Note3: The packing have to including into the vibration testing.

12.Touch Panel Information

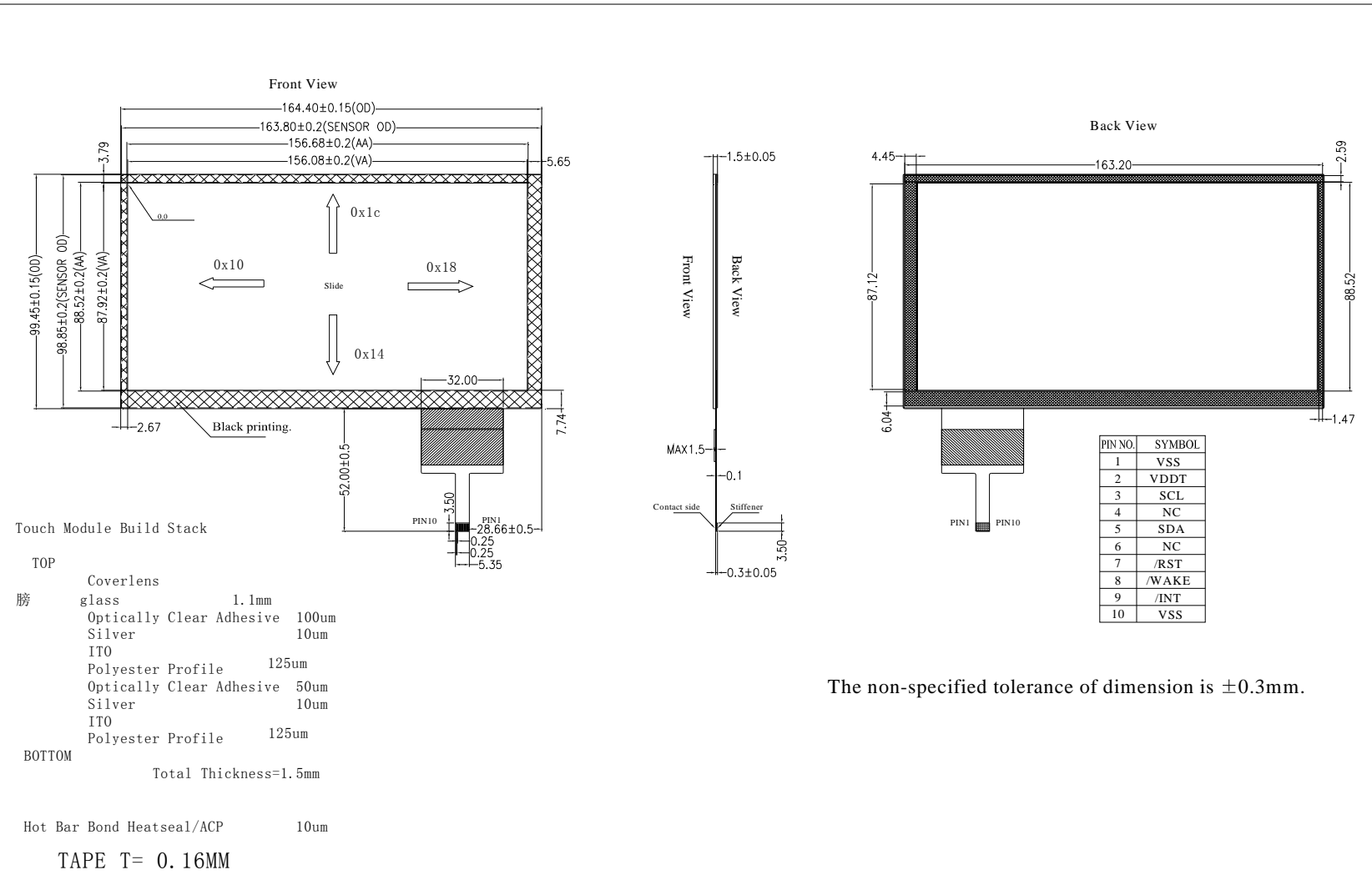

The non-specified tolerance of dimension is ±0.3mm.

12.1. CTP I2C Timing:

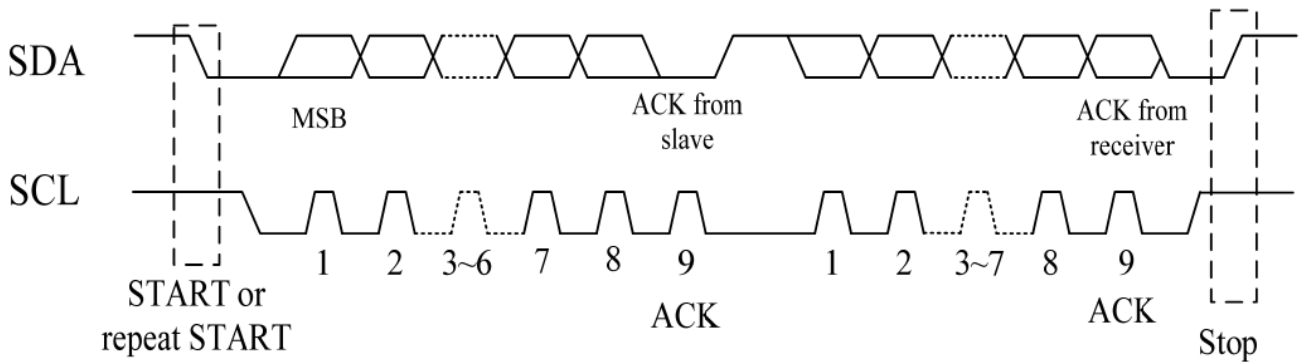

I2C Serial Data Transfer Format

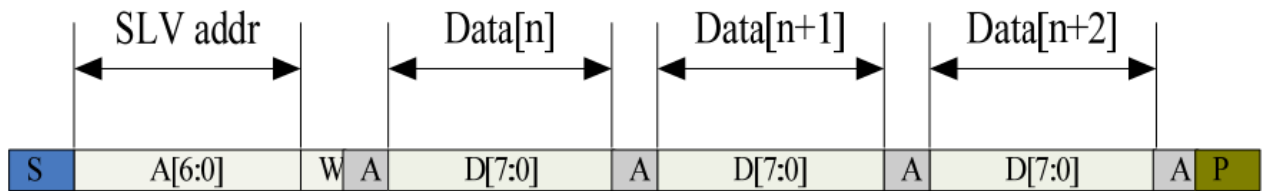

I2C master write, slave read

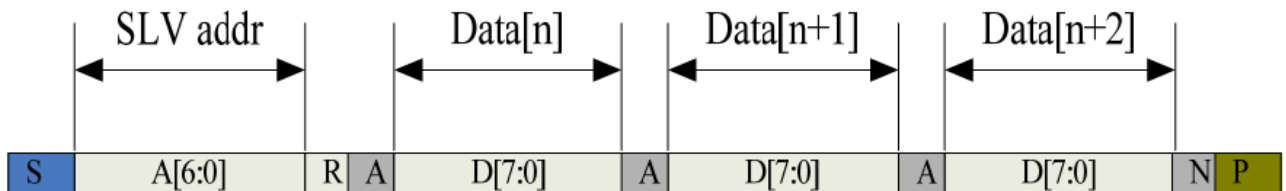

I2C master read, slave write

Mnemonics	Description
S	I2C Start or I2C Restart
A[6:0]	Slave address
R/W	READ/WRITE bit, '1' for read, '0' for write
A(N)	ACK(NACK) bit
P	STOP: the indication of the end of a packet (if this bit is missing, S will indicate the end of the current packet and the beginning of the next packet)

Lists the meanings of the mnemonics used in the above figures

Parameter	Unit	Min	Max
SCL frequency	KHz	0	400
Bus free time between a STOP and START condition	us	1.3	\
Hold time (repeated) START condition	us	0.6	\
Data setup time	ns	100	\
Setup time for a repeated START condition	us	0.6	\
Setup time for STOP condition	us	0.6	\

Interface Timing Characteristics

AS FOR STANDARD CTPM, HOST NEED TO USE BOTH INTERRUPT CONTROL SIGNAL AND SERIAL DATA INTERFACE TO GET THE TOUCH DATA. HERE IS THE TIMING TO GET TOUCH DATA.

WRITE BYTES TO I2C SLAVE

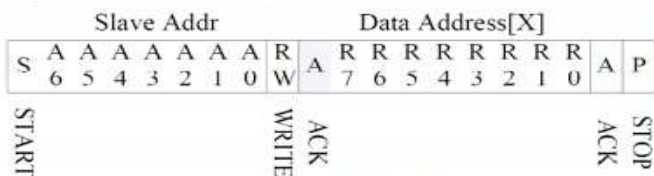
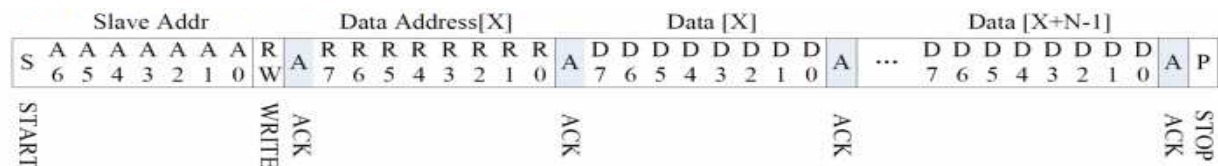

READ X BYTES FROM I2C SLAVE

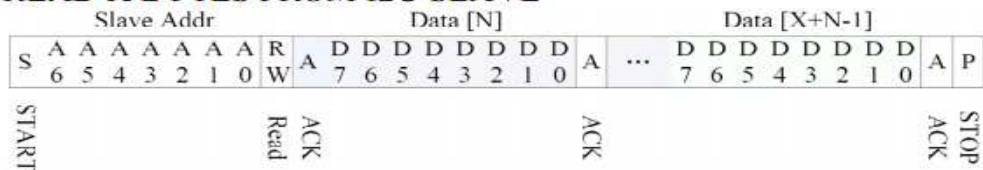

AS FOR STANDARD CTPM, HOST NEED TO USE BOTH INTERRUPT CONTROL SIGNAL AND SERIAL DATA INTERFACE TO GET THE TOUCH DATA, HERE IS THE TIMING TO GET TOUCH DATA.

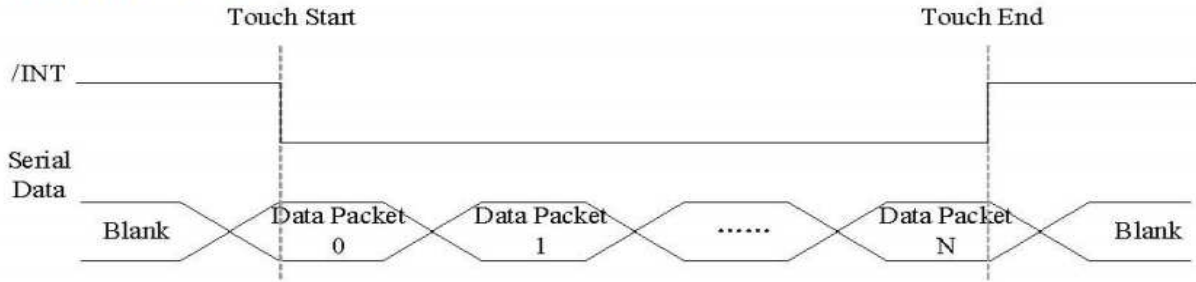

Address: 0X38

TOUCH DATA READ PROTOCOL

NAME	VALUE	DESCRIPTION
START CH	0X00	START COMMAND FOR CTPM TOUCH DATA PACKET,HOST MUST SEND CTPM A START CH COMMAND BEFORE READ TOUCH DATA
Lst READ BYTE~ LAST READ BYTE		TOUCH DATA PACKET SENT BY CTPM,EACH BYTE HAS 8-BIT DATA ,A TOUCH DATA PACKET CONSISTS OF N BYTE

Address	Name	Bit7	Bit6	Bit5	Bit4	Bit3	Bit2	Bit1	Bit0	Host Access
00h	Devide__Mode	—	Device Model[2:0]		—					RW
01h	Gest__ID	Gesture ID[7:0]								R
02h	TD__Status	—				Number of touch points[3:0]				R
03h	Touch1__XH	1 st Event Flag	—		1 st Touch X Position[11:8]				R	
04h	Touch1__XL	1 st Touch X Position[7:0]								R
05h	Touch1__YH	1 st Touch ID[3:0]				1 st Touch Y Position[11:8]				R
06h	Touch1__YL	1 st Touch Y Position[7:0]								R
09h	Touch2__XH	2 nd Event Flag	—		2 nd Touch X Position[11:8]				R	

0Ah	Touch2__XL	2 nd Touch X Position[7:0]	R	0Ah	Touch2__ XL
0Bh	Touch2__YH	2nd Touch ID[3:0]	2ndTouch Y Position[11:8]	0Bh	Touch2__ YH
0Ch	Touch2__YL	2nd Touch Y Position[7:0]	R	0Ch	Touch2__ YL
0Fh	Touch3__XH	3rdEvent Flag	—	3rdTouch X Position[11:8]	R
10h	Touch3__XL	3rd Touch X Position[7:0]			R
11h	Touch3__YH	3rdTouch ID[3:0]	3rdTouch Y Position[11:8]		R
12h	Touch3__YL	3rd Touch Y Position[7:0]			R
15h	Touch4__XH	4thEvent Flag	—	4thTouch X Position[11:8]	R
16h	Touch4__XL	4th Touch X Position[7:0]			R
17h	Touch4__YH	4thTouch ID[3:0]	4thTouch Y Position[11:8]		R
18h	Touch4__YL	4th Touch Y Position[7:0]			R
1Bh	Touch5__XH	5thEvent Flag	—	5thTouch X Position[11:8]	R
1Ch	Touch5__XL	5th Touch X Position[7:0]			R
1Dh	Touch5__YH	5thTouch ID[3:0]	5thTouch Y Position[11:8]		R
1Eh	Touch5__YL	5th Touch Y Position[7:0]			R

13. Contour Drawing

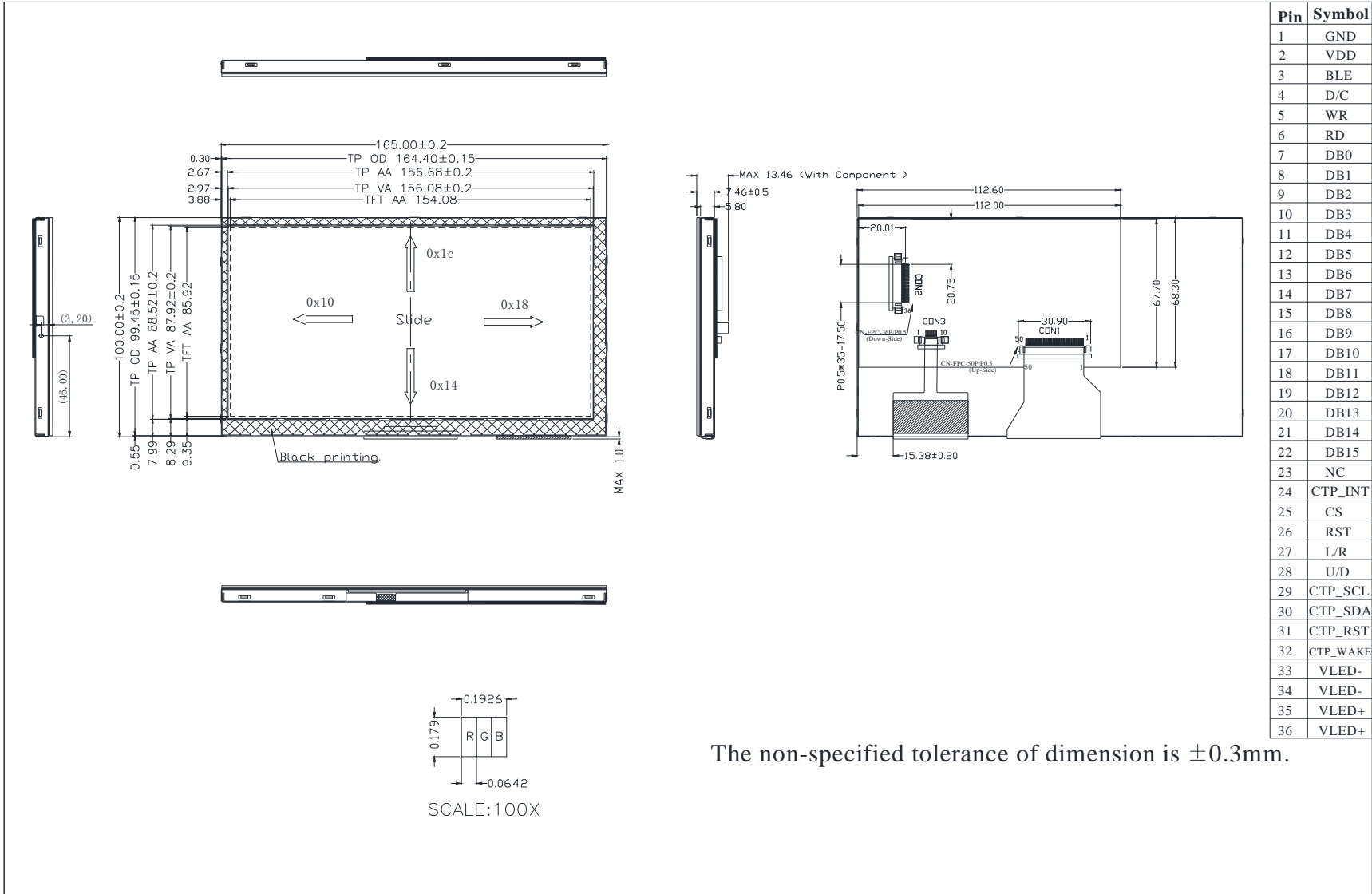

The non-specified tolerance of dimension is ±0.3mm.

14.Initial Code For Reference

```
void Initial_SSD1963()
{
    Write_Command(0x01);
    Delay_ms(10);
    Write_Command(0xe0); //START PLL
    Write_Parameter(0x01);
    Delay_ms(50);
    Write_Command(0xe0); //START PLL
    Write_Parameter(0x03);
    Delay_ms(5);

    Write_Command(0xb0);
    Write_Parameter(0x20);
    Write_Parameter(0x80);
    Write_Parameter(0x03);
    Write_Parameter(0x1f);
    Write_Parameter(0x01);
    Write_Parameter(0xdf);
    Write_Parameter(0x00);

    Write_Command(0xf0);
    Write_Parameter(0x03); //pixel data format, 0x03 is 16bit(565 format);0x00 is for 8-bit

    //Set the MN of PLL
    Write_Command(0xe2);
    Write_Parameter(0x1d);
    Write_Parameter(0x02);
    Write_Parameter(0x54);

    Write_Command(0xe6);
    Write_Parameter(0x04);
    Write_Parameter(0x6f);
    Write_Parameter(0x47);

    //Set front porch and back porch
    Write_Command(0xb4);
    Write_Parameter(0x04);
    Write_Parameter(0x20);
    Write_Parameter(0x00);
    Write_Parameter(0x2e);
    Write_Parameter(0xd2);
    Write_Parameter(0x00);
    Write_Parameter(0x00);
    Write_Parameter(0x00);

    Write_Command(0xb6);
    Write_Parameter(0x02);
```

Write_Parameter(0x0d);
Write_Parameter(0x00);
Write_Parameter(0x17);
Write_Parameter(0x16);
Write_Parameter(0x00);
Write_Parameter(0x00);

Write_Command(0x2a);
Write_Parameter(0x00);
Write_Parameter(0x00);
Write_Parameter(0x03);
Write_Parameter(0x1f);

Write_Command(0x2b);
Write_Parameter(0x00);
Write_Parameter(0x00);
Write_Parameter(0x01);
Write_Parameter(0x1f);

Write_Command(0xb8);
Write_Parameter(0x0f);
Write_Parameter(0x01);
Write_Command(0xba);
Write_Parameter(0x01);

Write_Command(0x29);
Write_Command(0x2c);

}



winstar LCM Sample Estimate Feedback Sheet

Module Number : _____

Page: 1

1、Panel Specification :

- 1. Panel Type : Pass NG , _____
- 2. View Direction : Pass NG , _____
- 3. Numbers of Dots : Pass NG , _____
- 4. View Area : Pass NG , _____
- 5. Active Area : Pass NG , _____
- 6. Operating Temperature : Pass NG , _____
- 7. Storage Temperature : Pass NG , _____
- 8. Others : _____

2、Mechanical Specification :

- 1. PCB Size : Pass NG , _____
- 2. Frame Size : Pass NG , _____
- 3. Material of Frame : Pass NG , _____
- 4. Connector Position : Pass NG , _____
- 5. Fix Hole Position : Pass NG , _____
- 6. Backlight Position : Pass NG , _____
- 7. Thickness of PCB : Pass NG , _____
- 8. Height of Frame to PCB : Pass NG , _____
- 9. Height of Module : Pass NG , _____
- 10. Others : Pass NG , _____

3、Relative Hole Size :

- 1. Pitch of Connector : Pass NG , _____
- 2. Hole size of Connector : Pass NG , _____
- 3. Mounting Hole size : Pass NG , _____
- 4. Mounting Hole Type : Pass NG , _____
- 5. Others : Pass NG , _____

4、Backlight Specification :

- 1. B/L Type : Pass NG , _____
- 2. B/L Color : Pass NG , _____
- 3. B/L Driving Voltage (Reference for LED Type) : Pass NG , _____
- 4. B/L Driving Current : Pass NG , _____
- 5. Brightness of B/L : Pass NG , _____
- 6. B/L Solder Method : Pass NG , _____
- 7. Others : Pass NG , _____

>> **Go to page 2** <<



Winstar Module Number : _____

Page: 2

5、Electronic Characteristics of Module :

- | | | |
|------------------------------|-------------------------------|-------------------------------------|
| 1. Input Voltage : | <input type="checkbox"/> Pass | <input type="checkbox"/> NG , _____ |
| 2. Supply Current : | <input type="checkbox"/> Pass | <input type="checkbox"/> NG , _____ |
| 3. Driving Voltage for LCD : | <input type="checkbox"/> Pass | <input type="checkbox"/> NG , _____ |
| 4. Contrast for LCD : | <input type="checkbox"/> Pass | <input type="checkbox"/> NG , _____ |
| 5. B/L Driving Method : | <input type="checkbox"/> Pass | <input type="checkbox"/> NG , _____ |
| 6. Negative Voltage Output : | <input type="checkbox"/> Pass | <input type="checkbox"/> NG , _____ |
| 7. Interface Function : | <input type="checkbox"/> Pass | <input type="checkbox"/> NG , _____ |
| 8. LCD Uniformity : | <input type="checkbox"/> Pass | <input type="checkbox"/> NG , _____ |
| 9. ESD test : | <input type="checkbox"/> Pass | <input type="checkbox"/> NG , _____ |
| 10. Others : | <input type="checkbox"/> Pass | <input type="checkbox"/> NG , _____ |

6、Summary :

Sales signature : _____

Customer Signature : _____

Date : / / _____