

WINSTAR Display

OLED SPECIFICATION

Model No:

WEO012864ULPP3N00000

SPECIFICATION**Version: H****CUSTOMER :****MODULE NO. : WEO012864ULPP3N00000****APPROVED BY:****(FOR CUSTOMER USE ONLY)**

| SALES BY | APPROVED BY | CHECKED BY | PREPARED BY |
|---------------|-------------|------------|-------------|
| | | | |
| RELEASE DATE: | | | |

 APPROVAL FOR SPECIFICATIONS ONLY **APPROVAL FOR SPECIFICATIONS AND SAMPLE**

MODEL NO :

| RECORDS OF REVISION | | | DOC. FIRST ISSUE |
|---------------------|------------|------------------|--|
| VERSION | DATE | REVISED PAGE NO. | SUMMARY |
| 0 | 2017/11/07 | | First release |
| A | 2018/07/05 | | Sample Spec |
| B | 2018/10/17 | | Modify VSL pin of the 3.1 Application recommendations. Add 6.3 Application Note for RAM mapping |
| C | 2018/11/27 | | Modify Static electricity test Content of Test |
| D | 2019/07/11 | | Modify Application recommendations |
| E | 2019/08/30 | | Modify Precautions in use of OLED Modules |
| F | 2019/10/04 | | Add 6.4 Command Table |
| G | 2019/12/18 | | Modify Reliability Test and measurement conditions & Inspection specification:" Accept no dense" modify to "ignore"& Precautions |
| H | 2020/01/16 | | Modify Initial code |

Contents

- 1.Module Classification Information
- 2.General Specification
- 3.Contour Drawing & Block Diagram
- 4.Interface Pin Function
- 5.Absolute Maximum Ratings
- 6.Electrical Characteristics
- 7.Optical Characteristics
- 8.OLED Lifetime
- 9.Reliability
- 10.Inspection specification
- 11.Precautions in use of OLED Modules

1. Module Classification Information

W E O 012864 U L P P 3 N 0 0 0 00
 ① ② ③ ④ ⑤ ⑥ ⑦ ⑧ ⑨ ⑩ ⑪ ⑫ ⑬ ⑭

| | | | | |
|----|-------------------------------------|---|-----------------|----------------|
| 1 | Brand : WINSTAR DISPLAY CORPORATION | | | |
| 2 | E : OLED | | | |
| 3 | Display Type | H : COB Character | G : COB Graphic | |
| | | O : COG | F : COG + FR | |
| | | P : COG + FR + PCB | X : TAB | |
| | | A : COG + PCB | | |
| 4 | Dot Matrix : 128 * 64 | | | |
| 5 | Serials code | | | |
| 6 | Emitting Color | A : Amber | R : Red | C : Full Color |
| | | B : Blue | W : White | |
| | | G : Green | L : Yellow | |
| | | S : Sky Blue | X : Dual Color | |
| 7 | Polarizer | P : With Polarizer; N: Without Polarizer A : Anti-glare Polarizer | | |
| 8 | Display Mode | P : Passive Matrix ; N : Active Matrix | | |
| 9 | Driver Voltage | 3 : 3.0~3.3V ; 5 : 5.0V | | |
| 10 | Touch Panel | N : Without touch panel; T: With touch panel | | |
| 11 | Product type | 0 : Standard 1 : Daylight Readable 2 : Transparent OLED (TOLED) 3 : Flexible OLED (FOLED) 4 : OLED Lighting | | |
| 12 | Inspection Grade | 0 : Standard 2 : Special grade C : Automotive grade Y : Consumer grade | | |
| 13 | Option | 0 : Default ; F : ZIF FPC ; H : Hot bar FPC; D : Demo Kit | | |
| 14 | Serial No. | Serial number(00~ZZ) | | |

2.General Specification

| Item | Dimension | Unit |
|------------------|--|------|
| Dot Martix | 128 x 64 Dots | — |
| Module dimension | 73.0 × 41.86 × 2.01 | mm |
| Active Area | 61.41 × 30.69 | mm |
| Pixel Size | 0.45 × 0.45 | mm |
| Pixel Pitch | 0.48 × 0.48 | mm |
| Display Mode | Passive Matrix | |
| Display Color | Yellow | |
| Drive Duty | 1/64 Duty | |
| IC | SSD1357 | |
| Interface | 8-bits 6800 and 8080 parallel, 4-line SPI, I2C | |
| Size | 2.7 inch | |

3. Contour Drawing & Block Diagram

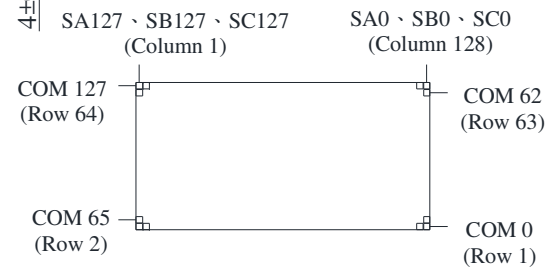
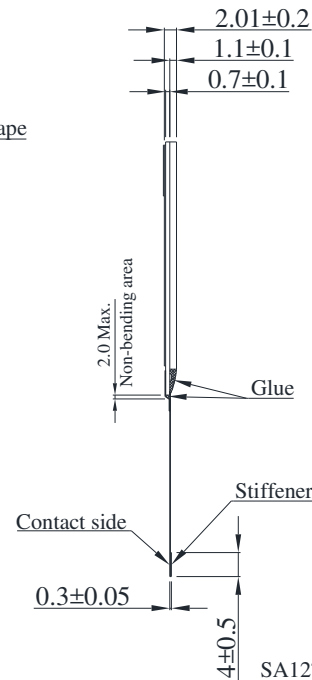
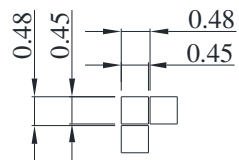
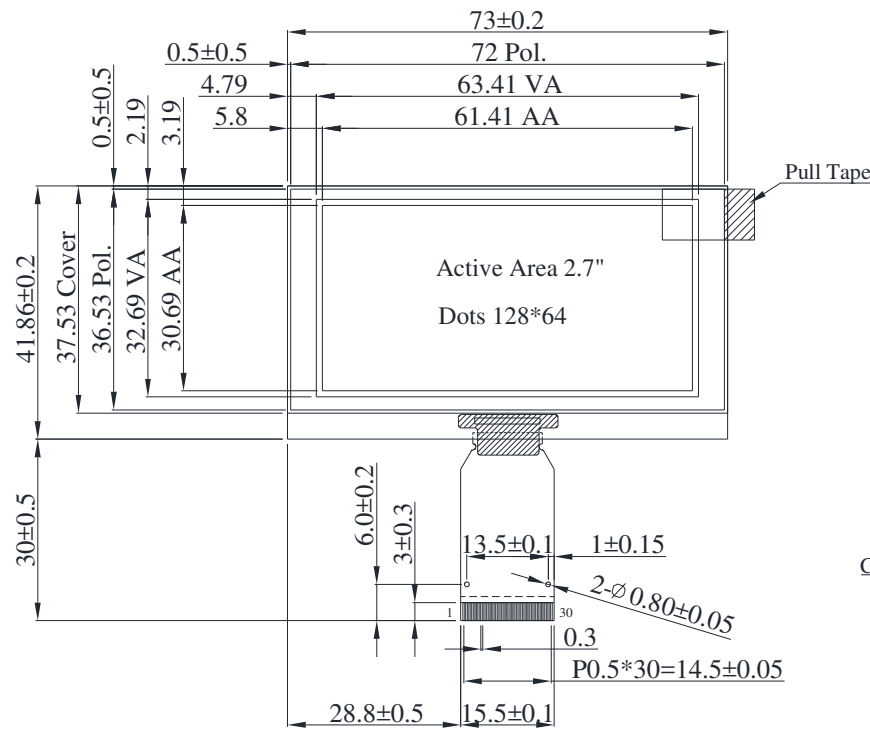

| PIN NO. | SYMBOL |
|---------|---------|
| 1 | NC(GND) |
| 2 | VSS |
| 3 | VCC |
| 4 | VCOMH |
| 5 | VLSS |
| 6 | D7 |
| 7 | D6 |
| 8 | D5 |
| 9 | D4 |
| 10 | D3 |
| 11 | D2 |
| 12 | D1 |
| 13 | D0 |
| 14 | E/RD# |
| 15 | R/W# |
| 16 | BS1 |
| 17 | BS2 |
| 18 | DC# |
| 19 | CS# |
| 20 | RES# |
| 21 | FR |
| 22 | IREF |
| 23 | NC |
| 24 | VDD |
| 25 | VP |
| 26 | VDD |
| 27 | VSL |
| 28 | VLSS |
| 29 | VCC |
| 30 | NC(GND) |

The non-specified tolerance of dimension is ± 0.3 mm.

3.1 Application recommendations

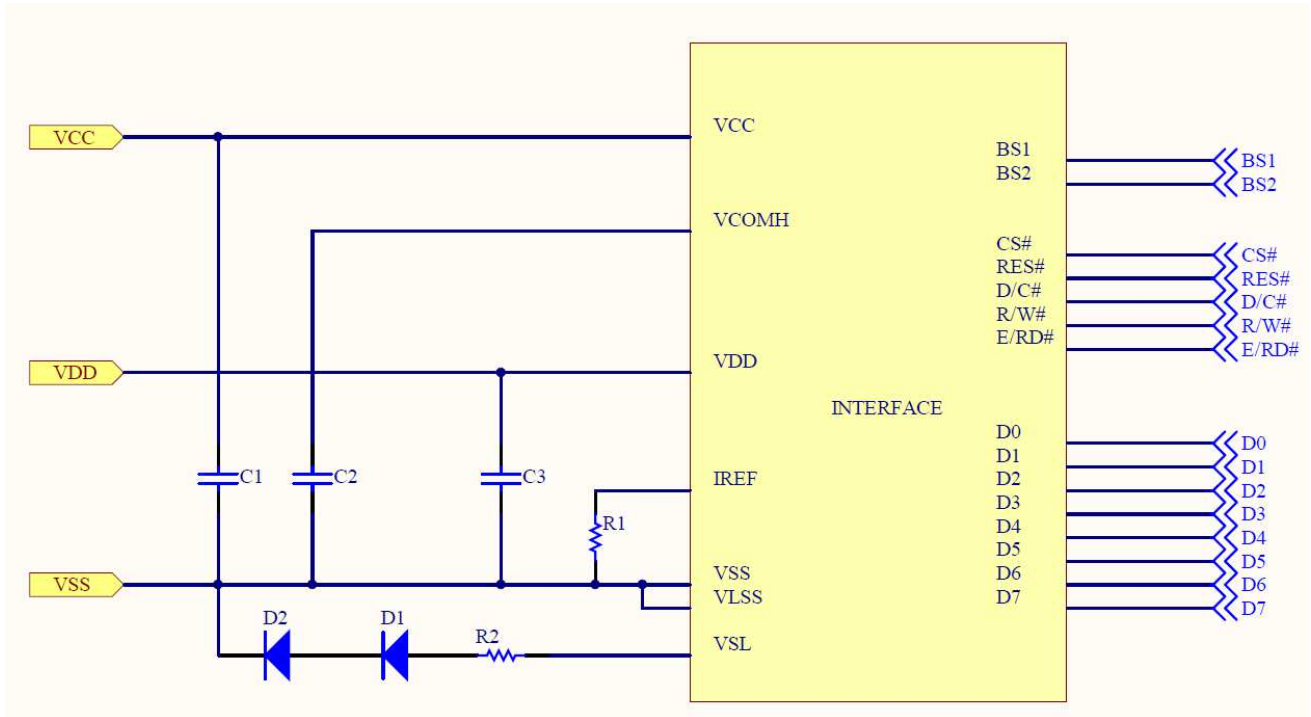

Recommended components:

C1, C2 : 2.2uF/25V/0603

C3 : 1.0uF/16V/0603

R2 : 20 ohm

D1,D2 : 1N4148

Bus Interface selection: (Must be set the BS[2:1], refer to item 4)

8-bits 6800 and 8080 parallel, 4-line SPI, I2C

Voltage at IREF = VCC – 2V. For VCC = 9V, IREF = 10uA:

$R1 = (\text{Voltage at IREF} - \text{VSS}) / \text{IREF}$

$= (9-2) / 10\mu$

$\approx 700\text{K ohm}$

Note:

The values are recommended value for 7.Optical Characteristics. Select appropriate value against module application.

4. Interface Pin Function

| No. | Symbol | Function |
|------|---------|---|
| 1 | NC(GND) | No connection. |
| 2 | VSS | Ground of Logic Circuit. This is a ground pin. It also acts as a reference for the logic pins. It must be connected to external ground. |
| 3 | VCC | Power supply for panel driving voltage. This is also the most positive power voltage supply pin. |
| 4 | VCOMH | Voltage Output High Level for COM Signal. This pin is the input pin for the voltage output high level for COM signals. A tantalum capacitor should be connected between this pin and VSS. |
| 5 | VLSS | Ground of Analog Circuit These are the analog ground pins. They should be connected to VSS externally. |
| 6~13 | D7~D0 | These pins are bi-directional data bus connecting to the MCU data bus. Unused pins are recommended to tie LOW. When serial interface mode is selected, D0 will be the serial clock input: SCLK; D1 will be the serial data input: SDIN and D2 should be kept NC. When I2C mode is selected, D2, D1 should be tied together and serve as SDAout, SDAin in application and D0 is the serial clock input, SCL. |
| 14 | E/RD# | This pin is MCU interface input. When 6800 interface mode is selected, this pin will be used as the Enable (E) signal. Read/write operation is initiated when this pin is pulled HIGH and the chip is selected. When 8080 interface mode is selected, this pin receives the Read (RD#) signal. Read operation is initiated when this pin is pulled LOW and the chip is selected. When serial or I2C interface is selected, this pin must be connected to VSS. |
| 15 | R/W# | This pin is read / write control input pin connecting to the MCU interface. When 6800 interface mode is selected, this pin will be used as Read/Write (R/W#) selection input. Read mode will be carried out when this pin is pulled HIGH and write mode when LOW. When 8080 interface mode is selected, this pin will be the Write (WR#) input. Data write operation is initiated when this pin is pulled LOW and the chip is selected. When serial or I2C interface is selected, this pin must be connected to VSS. |

| | | | | |
|----------|------------|--|-----|-----|
| 16 17 | BS1 BS2 | Communicating Protocol Select. These pins are MCU interface selection input. See the following table: | | |
| | | | BS1 | BS2 |
| | | I2C | 1 | 0 |
| | | 4-wire Serial | 0 | 0 |
| | | 8-bit 8080 Parallel | 1 | 1 |
| | | 8-bit 6800 Parallel | 0 | 1 |
| 18 | D/C# | <p>This pin is Data/Command control pin connecting to the MCU. When the pin is pulled HIGH, the data at D[7:0] will be interpreted as data.</p> <p>When the pin is pulled LOW, the data at D[7:0] will be transferred to a command register.</p> <p>In I2C mode, this pin acts as SA0 for slave address selection.</p> <p>When 3-wire serial interface is selected, this pin must be connected to VSS.</p> | | |
| 19 | CS# | <p>Chip Select</p> <p>This pin is the chip select input. The chip is enabled for MCU communication only when CS# is pulled low.</p> | | |
| 20 | RES# | <p>This pin is reset signal input.</p> <p>When the pin is pulled LOW, initialization of the chip is executed. Keep this pin pull HIGH during normal operation.</p> | | |
| 21 | FR | <p>Frame Frequency Triggering Signal</p> <p>This pin will send out a signal that could be used to identify the driver status.</p> <p>Nothing should be connected to this pin. It should be left open individually.</p> | | |
| 22 | IREF | <p>This pin is the segment output current reference pin.</p> <p>IREF is supplied externally.</p> | | |
| 23 | N.C. | <p>Reserved Pin</p> <p>The N.C. pin between function pins is reserved for compatible and flexible design.</p> | | |
| 24 | VDD | <p>Power Supply for I/O Pin.</p> <p>This pin is a power supply pin of I/O buffer. It should be connected to VCI or external source. All I/O signal should have VIH reference to VDDIO. When I/O signal pins (BS0~BS1, D0~D7, control signals...) pull high, they should be connected to VDDIO.</p> | | |
| 25 | VP | <p>Power Supply for Core Logic Circuit</p> <p>This is a voltage supply pin. It can be supplied externally (within the range of 2.4~2.6V) or regulated internally from VCI. A capacitor should be connected between this pin & VSS under all circumstances.</p> | | |
| 26 | VDD | <p>Power Supply for Operation.</p> <p>This is a voltage supply pin. It must be connected to external source & always be equal to or higher than VDD & VDDIO.</p> | | |
| 27 | VSL | <p>Voltage Output Low Level for SEG Signal</p> <p>This is segment voltage reference pin.</p> <p>When external VSL is not used, this pin should be left open.</p> <p>When external VSL is used, this pin should connect with resistor and diode to ground.</p> | | |

| | | |
|-----------|---------|--|
| 28 | VLSS | Ground of Analog Circuit These are the analog ground pins. They should be connected to VSS externally. |
| 29 | VCC | Power Supply for OEL Panel These are the most positive voltage supply pin of the chip. They must be connected to external source. |
| 30 | NC(GND) | No connection |

5. Absolute Maximum Ratings

| Parameter | Symbol | Min | Max | Unit | Notes |
|----------------------------|--------|------|------|------|-------|
| Supply Voltage for Logic | VDD | -0.3 | 4.0 | V | 1, 2 |
| Supply Voltage for Display | VCC | 0 | 15.0 | V | 1, 2 |
| Operating Temperature | TOP | -40 | +80 | °C | - |
| Storage Temperature | TSTG | -40 | +85 | °C | - |

Note 1: All the above voltages are on the basis of "VSS = 0V".

Note 2: When this module is used beyond the above absolute maximum ratings, permanent breakage of the module may occur. Also, for normal operations, it is desirable to use this module under the conditions according to Section 6 "Electrical Characteristics". If this module is used beyond these conditions, malfunctioning of the module can occur and the reliability of the module may deteriorate.

6. Electrical Characteristics

6.1 DC Electrical Characteristics

| Item | Symbol | Condition | Min | Typ | Max | Unit |
|-----------------------------------|--------|-----------|---------|------|---------|------|
| Supply Voltage for Logic | VDD | — | 2.8 | 3.0 | 3.3 | V |
| Supply Voltage for Display | VCC | — | 8.5 | 9.0 | 9.5 | V |
| High Level Input | VIH | — | 0.8×VDD | — | — | V |
| Low Level Input | VIL | — | — | — | 0.2×VDD | V |
| High Level Output | VOH | — | 0.9×VDD | — | — | V |
| Low Level Output | VOL | — | — | — | 0.1×VDD | V |
| 50% Check Board operating Current | | VCC =9.0V | — | 31.5 | 47.5 | mA |

6.2 Initial code

```
void Initial_SSD1357(){  
  
    write_command(0xFD);           //Set Command Lock  
    write_data(0x12);             //Unlock OLED driver IC  
  
    write_command(0xAE);          //Display OFF  
  
    write_command(0xA0);          //Set Re-map/Color Depth  
    write_data(0x12);             //A[7:6] Set Color Depth,  
    write_data(0x10);             //10b: Enable Dual-COM  
  
    write_command(0xA1);          //Set Display Start Line  
    write_data(0x00);  
  
    write_command(0xA2);          //Set Display Offset  
    write_data(0x00);  
  
    write_command(0xA6);          //normal display  
  
    write_command(0xB1);          //Set Phase Length  
    write_data(0xFF);  
  
    write_command(0xB3);          //Oscillator Frequency  
    write_data(0x20);             //105Hz  
  
    write_command(0xB6);          //Set Second Pre-charge period  
    write_data(0x0F);  
  
    write_command(0xB9);  
  
    write_command(0xBB);          //Set Pre-charge voltage  
    write_data(0x1F);  
  
    write_command(0xBE);          //Set VCOMH  
    write_data(0x07);             //0.86*VCC  
  
    write_command(0xC1);          //Contrast Current  
    write_data(0xAF);             //Blue contrast set  
    write_data(0xAF);             //Green contrast set  
    write_data(0xAF);             //Red contrast set  
  
    write_command(0xCA);          //Set MUX Ratio  
    write_data(0x7F);  
  
    write_command(0xAF);          //Display on  
  
}
```

6.3 Application Note for RAM mapping

Data bus to RAM mapping under different input mode

| Write data | | Data bus | | | | | | | |
|--------------|-------------|-------------|----|----|----|----|----|----|----|
| Depth | Input order | D7 | D6 | D5 | D4 | D3 | D2 | D1 | D0 |
| Mono | - | 0xFF / 0x00 | | | | | | | |
| 16Gray Scale | 1st | X | X | D3 | D2 | D1 | D0 | X | X |
| | 2nd | X | X | D3 | D2 | D1 | D0 | X | X |
| | 3rd | X | X | D3 | D2 | D1 | D0 | X | X |

Example code

(A) Mono

```

write_command(0xa0);
write_data(0x12);    //A[7:6] Set Color Depth,
                    //00b: mono
                    //10b: 16 Gray Scale

write_data(0x10);    //0x10: Enable Dual-COM ; 0x00 : Disable
write_command(0x15); //Column
write_data(0x00);
write_data(0x7F);
write_command(0x75); //Row
write_data(0x00);
write_data(0x3F);
write_command(0x5C);
for(y=0;y<64;y++)
{
    for(x=0;x<128;x++)
        { write_data(0xFF);    // or write_data(0x00);
        }
}

```

(B) 16 Gray Scale

```

write_command(0xA0);
write_data(0x92);    //A[7:6] Set Color Depth,
                    //00b: mono
                    //10b: 16 Graycale

write_data(0x10);    //0x10: Enable Dual-COM ; 0x00 : Disable
write_command(0x15); //Column
write_data(0x00);
write_data(0x7F);
write_command(0x75); //Row
write_data(0x00);
write_data(0x3F);
write_command(0x5C);
for(y=0x00;y<0x40;y++)
{
    for(x=0;x<64;x=x+4) //16 G.S.
        {
            for(z=0;z<8;z++)
                {
                    write_data(x);
                    write_data(x);
                    write_data(x);
                }
        }
}

```

6.4 Command Table

(D/C# = 0, R/W#(WR#)= 0, E(RD#) = 1) unless specific setting is stated

Single byte command (D/C# = 0), Multiple byte command (D/C# = 0 for first byte, D/C# = 1 for other bytes)

| Fundamental Command Table | | | | | | | | | | | |
|---------------------------|--------|----------------|----------------|----------------|----------------|----------------|----------------|----------------|----------------|---|---|
| D/C# | Hex | D7 | D6 | D5 | D4 | D3 | D2 | D1 | D0 | Command | Description |
| 0 | 15 | 0 | 0 | 0 | 1 | 0 | 1 | 0 | 1 | Set Column Address | A[6:0]: Start Address. [reset=0] B[6:0]: End Address. [reset=127] Range from 0 to 127 |
| 1 | A[6:0] | * | A ₆ | A ₅ | A ₄ | A ₃ | A ₂ | A ₁ | A ₀ | | |
| 1 | B[6:0] | * | B ₆ | B ₅ | B ₄ | B ₃ | B ₂ | B ₁ | B ₀ | | |
| 0 | 75 | 0 | 1 | 1 | 1 | 0 | 1 | 0 | 1 | Set Row Address | A[6:0]: Start Address. [reset=0] B[6:0]: End Address. [reset=127] Range from 0 to 127 |
| 1 | A[6:0] | * | A ₆ | A ₅ | A ₄ | A ₃ | A ₂ | A ₁ | A ₀ | | |
| 1 | B[6:0] | * | B ₆ | B ₅ | B ₄ | B ₃ | B ₂ | B ₁ | B ₀ | | |
| 0 | 5C | 0 | 1 | 0 | 1 | 1 | 1 | 0 | 0 | Write RAM Command | Enable MCU to write Data into RAM |
| 0 | 5D | 0 | 1 | 0 | 1 | 1 | 1 | 0 | 1 | Read RAM Command | Enable MCU to read Data from RAM |
| 0 | A0 | 1 | 0 | 1 | 0 | 0 | 0 | 0 | 0 | Set Re-map / Color Depth (Display RAM to Panel) | A[0]=0b, Horizontal address increment [reset] A[0]=1b, Vertical address increment |
| 1 | A[7:0] | A ₇ | A ₆ | A ₅ | A ₄ | A ₃ | A ₂ | A ₁ | A ₀ | | A[1]=0b, Column address 0 is mapped to SEG0 [reset] A[1]=1b, Column address 127 is mapped to SEG0 |
| 1 | B[7:0] | 0 | 0 | 0 | 0 | 0 | 0 | 0 | 0 | | A[2]=0b, Color sequence: A → B → C [reset] A[2]=1b, Color sequence is swapped: C → B → A |
| | | | | | | | | | | | A[3]=0b, Reserved [reset] A[3]=1b, Reserved |
| | | | | | | | | | | | A[4]=0b, Scan from COM0 to COM[N-1] [reset] A[4]=1b, Scan from COM[N-1] to COM0. Where N is the Multiplex ratio. |
| | | | | | | | | | | | A[5]=0b, Disable COM Split Odd Even A[5]=1b, Enable COM Split Odd Even [reset] |
| | | | | | | | | | | | A[7:6] Set Color Depth, 00b: 256color 01b: 65k color [reset] 10b: 262k color 11b Pseudo 262k color, 16-bit format 2 |
| | | | | | | | | | | | Refer to Product Preview Table 6-6 for details |

| Fundamental Command Table | | | | | | | | | | | |
|---------------------------|--------------|---------------------|---------------------|---------------------|---------------------|---------------------|---------------------|---------------------|---------------------|---|---|
| D/C# | Hex | D7 | D6 | D5 | D4 | D3 | D2 | D1 | D0 | Command | Description |
| 0 1 | A1 A[6:0] | 1 * | 0 A ₆ | 1 A ₅ | 0 A ₄ | 0 A ₃ | 0 A ₂ | 0 A ₁ | 1 A ₀ | Set Display Start Line | Set vertical scroll by RAM from 0~127. [reset=00h] |
| 0 1 | A2 A[6:0] | 1 * | 0 A ₆ | 1 A ₅ | 0 A ₄ | 0 A ₃ | 0 A ₂ | 1 A ₁ | 0 A ₀ | Set Display Offset | Set vertical scroll by Row from 0-127. [reset=00h] |
| 0 | A4~A7 | 1 | 0 | 1 | 0 | 0 | 1 | X ₁ | X ₀ | Set Display Mode | A4h: All OFF A5h: All ON (All pixels have GS63) A6h : Reset to normal display [reset] A7h: Inverse Display (GS0 -> GS63, GS1 -> GS62, ...) |
| 0 | AE~AF | 1 | 0 | 1 | 0 | 1 | 1 | 1 | X ₀ | Set Sleep mode ON/OFF | AEh = Sleep mode On (Display OFF) AFh = Sleep mode OFF (Display ON) |
| 0 1 | B1 A[7:0] | 1 A ₇ | 0 A ₆ | 1 A ₅ | 1 A ₄ | 0 A ₃ | 0 A ₂ | 0 A ₁ | 1 A ₀ | Set Reset (Phase 1) / Pre-charge (Phase 2) period | A[3:0] Phase 1 period of 2~30 DCLK(s) clocks [reset=0100b] A[3:0]: 0 invalid 1 = 2 DCLKs 2 = 4 DCLKs : 15 = 30DCLKs A[7:4] Phase 2 period of 2~30 DCLK(s) clocks [reset=1000b] A[7:4]: 0 invalid 1 = 2 DCLKs 2 = 4 DCLKs : 15 =30DCLKs Note (1) 0 DCLK is invalid in phase 1 & phase 2 |

| Fundamental Command Table | | | | | | | | | | | | | | | | | | | | | | | | | | | | | | | | | |
|---------------------------------|---|--|--|--|--|--|--|--|--|---|--|--------|--------|------|-------------|------|-------------|------|-------------|------|-------------|------|--------------|------|--------------|------|--------------|------|---------------|------|---------------|--------|---------|
| D/C# | Hex | D7 | D6 | D5 | D4 | D3 | D2 | D1 | D0 | Command | Description | | | | | | | | | | | | | | | | | | | | | | |
| 0 1 | B3 A[7:0] | 1 A ₇ | 0 A ₆ | 1 A ₅ | 1 A ₄ | 0 A ₃ | 0 A ₂ | 1 A ₁ | 1 A ₀ | Front Clock Divider (DivSet)/ Oscillator Frequency | <p>A[3:0] [reset=0000b], divide by DIVSET where</p> <table border="1"> <thead> <tr> <th>A[3:0]</th> <th>DIVSET</th> </tr> </thead> <tbody> <tr><td>0000</td><td>divide by 1</td></tr> <tr><td>0001</td><td>divide by 2</td></tr> <tr><td>0010</td><td>divide by 4</td></tr> <tr><td>0011</td><td>divide by 8</td></tr> <tr><td>0100</td><td>divide by 16</td></tr> <tr><td>0101</td><td>divide by 32</td></tr> <tr><td>0110</td><td>divide by 64</td></tr> <tr><td>0111</td><td>divide by 128</td></tr> <tr><td>1000</td><td>divide by 256</td></tr> <tr><td>>=1001</td><td>invalid</td></tr> </tbody> </table> <p>A[7:4] Oscillator frequency, frequency increases as level increases [reset=0010b]</p> | A[3:0] | DIVSET | 0000 | divide by 1 | 0001 | divide by 2 | 0010 | divide by 4 | 0011 | divide by 8 | 0100 | divide by 16 | 0101 | divide by 32 | 0110 | divide by 64 | 0111 | divide by 128 | 1000 | divide by 256 | >=1001 | invalid |
| A[3:0] | DIVSET | | | | | | | | | | | | | | | | | | | | | | | | | | | | | | | | |
| 0000 | divide by 1 | | | | | | | | | | | | | | | | | | | | | | | | | | | | | | | | |
| 0001 | divide by 2 | | | | | | | | | | | | | | | | | | | | | | | | | | | | | | | | |
| 0010 | divide by 4 | | | | | | | | | | | | | | | | | | | | | | | | | | | | | | | | |
| 0011 | divide by 8 | | | | | | | | | | | | | | | | | | | | | | | | | | | | | | | | |
| 0100 | divide by 16 | | | | | | | | | | | | | | | | | | | | | | | | | | | | | | | | |
| 0101 | divide by 32 | | | | | | | | | | | | | | | | | | | | | | | | | | | | | | | | |
| 0110 | divide by 64 | | | | | | | | | | | | | | | | | | | | | | | | | | | | | | | | |
| 0111 | divide by 128 | | | | | | | | | | | | | | | | | | | | | | | | | | | | | | | | |
| 1000 | divide by 256 | | | | | | | | | | | | | | | | | | | | | | | | | | | | | | | | |
| >=1001 | invalid | | | | | | | | | | | | | | | | | | | | | | | | | | | | | | | | |
| 0 1 | B6 A[3:0] | 1 0 | 0 0 | 1 0 | 1 0 | 0 A ₃ | 1 A ₂ | 0 A ₁ | 0 A ₀ | Set Second Pre-charge Period | <p>A[3:0] Set Second Pre-charge Period</p> <p>0000b invalid 0001b 1 DCLKS 0010b 2 DCLKS 1000 8 DCLKS [reset] 1111 15 DCLKS</p> | | | | | | | | | | | | | | | | | | | | | | |
| 0 1 1 1 1 1 1 | B8 A1[7:0] A2[7:0] . . . A62[7:0] A63[7:0] | 1 A1 ₇ A2 ₇ . . . A62 ₇ A63 ₇ | 0 A1 ₆ A2 ₆ . . . A62 ₆ A63 ₆ | 1 A1 ₅ A2 ₅ . . . A62 ₅ A63 ₅ | 1 A1 ₄ A2 ₄ . . . A62 ₄ A63 ₄ | 1 A1 ₃ A2 ₃ . . . A62 ₃ A63 ₃ | 0 A1 ₂ A2 ₂ . . . A62 ₂ A63 ₂ | 0 A1 ₁ A2 ₁ . . . A62 ₁ A63 ₁ | 0 A1 ₀ A2 ₀ . . . A62 ₀ A63 ₀ | Master Look Up Table for Gray Scale Pulse width (Color A,B,C) | <p>The next 63 data bytes define Gray Scale (GS) Table by setting the gray scale pulse width in unit of DCLK's (ranges from 0d ~ 180d).</p> <p>A1[7:0]: Gamma Setting for GS1, A2[7:0]: Gamma Setting for GS2, . A62[7:0]: Gamma Setting for GS62, A63[7:0]: Gamma Setting for GS63</p> <p>Note ⁽¹⁾ 0 ≤ Setting of GS1 < Setting of GS2 < Setting of GS3..... < Setting of GS62 < Setting of GS63 ⁽²⁾ GS0 does not has pre-charge and current drive stages. ⁽³⁾ GS1 can be set as only pre-charge but no current drive stage by input gamma setting for GS1 equals 0. ⁽⁴⁾ When command B8h is input only, color A, B, C will follow the master LUT. ⁽⁵⁾ When command BCh is input, it selects individual LUT for color A, GS1~31A; When command BDh is input, it selects individual LUT for color C, GS1~31C ⁽⁶⁾ To select individual LUT for color B, A and C, command B8h should be input before command BCh and BDh,</p> | | | | | | | | | | | | | | | | | | | | | | |

| Fundamental Command Table | | | | | | | | | | | | | | | | | | | | | | | | | | | | | | | |
|--------------------------------------|---|--|--|--|--|--|--|--|--|---|---|---------|----------|--------------------|---------------|---------------|------------------------|---------------|---------------|---------------|---------------|---------------|--------------------------------|-------|-----|--------------------------|------------------|------------------|------------------|--|------------------|
| D/C# | Hex | D7 | D6 | D5 | D4 | D3 | D2 | D1 | D0 | Command | Description | | | | | | | | | | | | | | | | | | | | |
| 0 | B9 | 1 | 0 | 1 | 1 | 1 | 0 | 0 | 1 | Use Built-in Linear LUT [reset= linear] | Reset to default Look Up Table: | | | | | | | | | | | | | | | | | | | | |
| | | | | | | | | | | | <table border="1"> <thead> <tr> <th>Color A</th> <th>Color B</th> <th>Color C</th> </tr> </thead> <tbody> <tr> <td>GS1A = 0 DCLK</td> <td>GS1B = 0 DCLK</td> <td>GS1C = 0 DCLK</td> </tr> <tr> <td>GS2A = 4 DCLK</td> <td>GS2B = 2 DCLK</td> <td>GS2C = 4 DCLK</td> </tr> <tr> <td>GS3A = 8 DCLK</td> <td>GS3B = 4 DCLK</td> <td>GS3C = 8 DCLK</td> </tr> <tr> <td>...</td> <td>...</td> <td>...</td> </tr> <tr> <td>GS31A = 120 DCLK</td> <td>GS62B = 122 DCLK</td> <td>GS31C = 120 DCLK</td> </tr> <tr> <td></td> <td>GS63B = 124 DCLK</td> <td></td> </tr> </tbody> </table> | Color A | Color B | Color C | GS1A = 0 DCLK | GS1B = 0 DCLK | GS1C = 0 DCLK | GS2A = 4 DCLK | GS2B = 2 DCLK | GS2C = 4 DCLK | GS3A = 8 DCLK | GS3B = 4 DCLK | GS3C = 8 DCLK | ... | ... | ... | GS31A = 120 DCLK | GS62B = 122 DCLK | GS31C = 120 DCLK | | GS63B = 124 DCLK |
| Color A | Color B | Color C | | | | | | | | | | | | | | | | | | | | | | | | | | | | | |
| GS1A = 0 DCLK | GS1B = 0 DCLK | GS1C = 0 DCLK | | | | | | | | | | | | | | | | | | | | | | | | | | | | | |
| GS2A = 4 DCLK | GS2B = 2 DCLK | GS2C = 4 DCLK | | | | | | | | | | | | | | | | | | | | | | | | | | | | | |
| GS3A = 8 DCLK | GS3B = 4 DCLK | GS3C = 8 DCLK | | | | | | | | | | | | | | | | | | | | | | | | | | | | | |
| ... | ... | ... | | | | | | | | | | | | | | | | | | | | | | | | | | | | | |
| GS31A = 120 DCLK | GS62B = 122 DCLK | GS31C = 120 DCLK | | | | | | | | | | | | | | | | | | | | | | | | | | | | | |
| | GS63B = 124 DCLK | | | | | | | | | | | | | | | | | | | | | | | | | | | | | | |
| 0 1 | BB A[4:0] | 1 0 | 0 0 | 1 0 | 1 A ₄ | 1 A ₃ | 0 A ₂ | 1 A ₁ | 1 A ₀ | Set Pre-charge voltage | Set pre-charge voltage level.[reset = 11110b] | | | | | | | | | | | | | | | | | | | | |
| | | | | | | | | | | | <table border="1"> <thead> <tr> <th>A[4:0]</th> <th>Hex code</th> <th>pre-charge voltage</th> </tr> </thead> <tbody> <tr> <td>00000</td> <td>00h</td> <td>0.10 x V_{CC}</td> </tr> <tr> <td>:</td> <td>:</td> <td>:</td> </tr> <tr> <td>11110</td> <td>1Eh</td> <td>0.50 x V_{CC} [reset]</td> </tr> <tr> <td>11111</td> <td>1Fh</td> <td>0.5133 x V_{CC}</td> </tr> </tbody> </table> <p>Note ⁽¹⁾Pre-charge voltage level must be smaller than COM deselect voltage level</p> | A[4:0] | Hex code | pre-charge voltage | 00000 | 00h | 0.10 x V _{CC} | : | : | : | 11110 | 1Eh | 0.50 x V _{CC} [reset] | 11111 | 1Fh | 0.5133 x V _{CC} | | | | | |
| A[4:0] | Hex code | pre-charge voltage | | | | | | | | | | | | | | | | | | | | | | | | | | | | | |
| 00000 | 00h | 0.10 x V _{CC} | | | | | | | | | | | | | | | | | | | | | | | | | | | | | |
| : | : | : | | | | | | | | | | | | | | | | | | | | | | | | | | | | | |
| 11110 | 1Eh | 0.50 x V _{CC} [reset] | | | | | | | | | | | | | | | | | | | | | | | | | | | | | |
| 11111 | 1Fh | 0.5133 x V _{CC} | | | | | | | | | | | | | | | | | | | | | | | | | | | | | |
| 0 1 1 1 1 1 1 1 | BC A1[7:0] A2[7:0] . . . A30[7:0] A31[7:0] | 1 A1 ₇ A2 ₇ . . . A30 ₇ A31 ₇ | 0 A1 ₆ A2 ₆ . . . A30 ₆ A31 ₆ | 1 A1 ₅ A2 ₅ . . . A30 ₅ A31 ₅ | 1 A1 ₄ A2 ₄ . . . A30 ₄ A31 ₄ | 1 A1 ₃ A2 ₃ . . . A30 ₃ A31 ₃ | 1 A1 ₂ A2 ₂ . . . A30 ₂ A31 ₂ | 0 A1 ₁ A2 ₁ . . . A30 ₁ A31 ₁ | 0 A1 ₀ A2 ₀ . . . A30 ₀ A31 ₀ | Individual Look Up Table for Gray Scale Pulse width (Color A) | The next 31 data bytes define Gray Scale (GS) Table by setting the gray scale pulse width in unit of DCLK's (ranges from 0d ~ 180d) for color A. | | | | | | | | | | | | | | | | | | | | |
| | | | | | | | | | | | <p>A1[7:0]: Gamma Setting for GS1A, A2[7:0]: Gamma Setting for GS2A, : A62[7:0]: Gamma Setting for GS30A, A63[7:0]: Gamma Setting for GS31A</p> <p>Note ⁽¹⁾ 0 ≤ Setting of GS1 < Setting of GS2 < Setting of GS3..... < Setting of GS30 < Setting of GS31 ⁽²⁾ GS0 does not has pre-charge and current drive stages. ⁽³⁾ GS1 can be set as only pre-charge but no current drive stage by input gamma setting for GS1 equals 0. ⁽⁴⁾ When command B8h is input, it selects one LUT for color A, B and C. i.e. GS1~31A, GS1~63B and GS1~31C are updated. ⁽⁵⁾ Command B8h should be input before command BCh and BDh to select individual LUT for color B, A and C.</p> | | | | | | | | | | | | | | | | | | | | |

| Fundamental Command Table | | | | | | | | | | | | | | | | | | | | | | | | | | | | | |
|---------------------------|----------|--------------------------------|------------------|------------------|------------------|------------------|------------------|------------------|------------------|---|---|--|-------------------------------|-------------------|-----|-----|------------------------|---|---|---|-----|-----|--------------------------------|---|---|---|-----|-----|------------------------|
| D/C# | Hex | D7 | D6 | D5 | D4 | D3 | D2 | D1 | D0 | Command | Description | | | | | | | | | | | | | | | | | | |
| 0 | BD | 1 | 0 | 1 | 1 | 1 | 1 | 0 | 1 | Individual Look Up Table for Gray Scale Pulse width (Color C) | The next 31 data bytes define Gray Scale (GS) Table by setting the gray scale pulse width in unit of DCLK's (ranges from 0d ~ 180d) for color C. A1[7:0]: Gamma Setting for GS1C, A2[7:0]: Gamma Setting for GS2C, : A62[7:0]: Gamma Setting for GS30C, A63[7:0]: Gamma Setting for GS31C Note (1) 0 ≤ Setting of GS1 < Setting of GS2 < Setting of GS3..... < Setting of GS30 < Setting of GS31 (2) GS0 does not has pre-charge and current drive stages. (3) GS1 can be set as only pre-charge but no current drive stage by input gamma setting for GS1 equals 0. (4) When command B8h is input, it selects one LUT for color A, B and C. i.e. GS1~31A, GS1~63B and GS1~31C are updated. (5) Command B8h should be input before command BCh and BDh to select individual LUT for color B, A and C. | | | | | | | | | | | | | | | | | | |
| 1 | A1[7:0] | A1 ₇ | A1 ₆ | A1 ₅ | A1 ₄ | A1 ₃ | A1 ₂ | A1 ₁ | A1 ₀ | | | | | | | | | | | | | | | | | | | | |
| 1 | A2[7:0] | A2 ₇ | A2 ₆ | A2 ₅ | A2 ₄ | A2 ₃ | A2 ₂ | A2 ₁ | A2 ₀ | | | | | | | | | | | | | | | | | | | | |
| 1 | . | . | . | . | . | . | . | . | . | | | | | | | | | | | | | | | | | | | | |
| 1 | . | . | . | . | . | . | . | . | . | | | | | | | | | | | | | | | | | | | | |
| 1 | . | . | . | . | . | . | . | . | . | | | | | | | | | | | | | | | | | | | | |
| 1 | A30[7:0] | A30 ₇ | A30 ₆ | A30 ₅ | A30 ₄ | A30 ₃ | A30 ₂ | A30 ₁ | A30 ₀ | | | | | | | | | | | | | | | | | | | | |
| 1 | A31[7:0] | A31 ₇ | A31 ₆ | A31 ₅ | A31 ₄ | A31 ₃ | A31 ₂ | A31 ₁ | A31 ₀ | | | | | | | | | | | | | | | | | | | | |
| 0 | BE | 1 | 0 | 1 | 1 | 1 | 1 | 1 | 0 | | | Set COM deselect voltage level [reset = 05h] | Set V _{COMH} Voltage | | | | | | | | | | | | | | | | |
| 1 | A[2:0] | 0 | 0 | 0 | 0 | 0 | A ₂ | A ₁ | A ₀ | | | | | | | | | | | | | | | | | | | | |
| | | | | | | | | | | | <table border="1"> <thead> <tr> <th>A[2:0]</th> <th>Hex code</th> <th>V_{COMH}</th> </tr> </thead> <tbody> <tr> <td>000</td> <td>00h</td> <td>0.72 x V_{CC}</td> </tr> <tr> <td>:</td> <td>:</td> <td>:</td> </tr> <tr> <td>101</td> <td>05h</td> <td>0.82 x V_{CC} [reset]</td> </tr> <tr> <td>:</td> <td>:</td> <td>:</td> </tr> <tr> <td>111</td> <td>07h</td> <td>0.86 x V_{CC}</td> </tr> </tbody> </table> | A[2:0] | Hex code | V _{COMH} | 000 | 00h | 0.72 x V _{CC} | : | : | : | 101 | 05h | 0.82 x V _{CC} [reset] | : | : | : | 111 | 07h | 0.86 x V _{CC} |
| A[2:0] | Hex code | V _{COMH} | | | | | | | | | | | | | | | | | | | | | | | | | | | |
| 000 | 00h | 0.72 x V _{CC} | | | | | | | | | | | | | | | | | | | | | | | | | | | |
| : | : | : | | | | | | | | | | | | | | | | | | | | | | | | | | | |
| 101 | 05h | 0.82 x V _{CC} [reset] | | | | | | | | | | | | | | | | | | | | | | | | | | | |
| : | : | : | | | | | | | | | | | | | | | | | | | | | | | | | | | |
| 111 | 07h | 0.86 x V _{CC} | | | | | | | | | | | | | | | | | | | | | | | | | | | |
| 0 | C1 | 1 | 1 | 0 | 0 | 0 | 0 | 0 | 1 | Set Contrast Current for Color A,B,C | A[7:0] Contrast Value Color A [reset=7Fh] | | | | | | | | | | | | | | | | | | |
| 1 | A[7:0] | A ₇ | A ₆ | A ₅ | A ₄ | A ₃ | A ₂ | A ₁ | A ₀ | | B[7:0] Contrast Value Color B [reset=7Fh] | | | | | | | | | | | | | | | | | | |
| 1 | B[7:0] | B ₇ | B ₆ | B ₅ | B ₄ | B ₃ | B ₂ | B ₁ | B ₀ | | C[7:0] Contrast Value Color C [reset=7Fh] | | | | | | | | | | | | | | | | | | |
| 1 | C[7:0] | C ₇ | C ₆ | C ₅ | C ₄ | C ₃ | C ₂ | C ₁ | C ₀ | | | | | | | | | | | | | | | | | | | | |
| 0 | C7 | 1 | 1 | 0 | 0 | 0 | 1 | 1 | 1 | Master Contrast Current Control | A[3:0] : | | | | | | | | | | | | | | | | | | |
| 1 | A[3:0] | * | * | * | * | A ₃ | A ₂ | A ₁ | A ₀ | | 0000b reduce output currents for all colors to 1/16 0001b reduce output currents for all colors to 2/16 1110b reduce output currents for all colors to 15/16 1111b no change [reset] | | | | | | | | | | | | | | | | | | |
| 0 | CA | 1 | 1 | 0 | 0 | 1 | 0 | 1 | 0 | Set MUX Ratio | A[6:0] MUX ratio 4MUX ~ 128MUX, [reset=127], (Range from 3 to 127) | | | | | | | | | | | | | | | | | | |
| 1 | A[6:0] | 0 | A ₆ | A ₅ | A ₄ | A ₃ | A ₂ | A ₁ | A ₀ | | | | | | | | | | | | | | | | | | | | |
| 0 | E3 | 1 | 1 | 1 | 0 | 0 | 0 | 1 | 1 | NOP | Command for No Operation | | | | | | | | | | | | | | | | | | |
| | | | | | | | | | | | | | | | | | | | | | | | | | | | | | |

| Fundamental Command Table | | | | | | | | | | | |
|---------------------------|--------|----------------|----------------|----------------|----------------|----------------|----------------|----------------|----------------|------------------|--|
| D/C# | Hex | D7 | D6 | D5 | D4 | D3 | D2 | D1 | D0 | Command | Description |
| 0 | FD | 1 | 1 | 1 | 1 | 1 | 1 | 0 | 1 | Set Command Lock | A[7:0]: MCU protection status [reset = 12h] |
| 1 | A[7:0] | A ₇ | A ₆ | A ₅ | A ₄ | A ₃ | A ₂ | A ₁ | A ₀ | | A[7:0] = 12h, Unlock OLED driver IC MCU interface from entering command [reset] A[7:0] = 16h, Lock OLED driver IC MCU interface from entering command |
| | | | | | | | | | | | Note ⁽¹⁾ The locked OLED driver IC MCU interface prohibits all commands and memory access except the FDh command. |

Note

(1) "*" stands for "Don't care".

Graphic Acceleration Command List

Set (GAC) (D/C# = 0, R/W#(WR#)= 0, E(RD#) = 1) unless specific setting is stated

Single byte command (D/C# = 0), Multiple byte command (D/C# = 0 for first byte, D/C# = 1 for other bytes)

| Graphic acceleration command | | | | | | | | | | Command | Description |
|------------------------------|--------|----|----|----|----|----|----|----|----|-------------------|---|
| D/C# | Hex | D7 | D6 | D5 | D4 | D3 | D2 | D1 | D0 | | |
| 0 | 96 | 1 | 0 | 0 | 1 | 0 | 1 | 1 | 0 | Horizontal Scroll | A[7:0] = 00000000b No scrolling |
| 1 | A[7:0] | A7 | A6 | A5 | A4 | A3 | A2 | A1 | A0 | | A[7:0] = 00000001b to 00111111b |
| 1 | B[6:0] | 0 | B6 | B5 | B4 | B3 | B2 | B1 | B0 | | Scroll towards SEG127 with 1 column offset |
| 1 | C[7:0] | 0 | C6 | C5 | C4 | C3 | C2 | C1 | C0 | | A[7:0] = 01000000b to 11111111b |
| 1 | D[6:0] | 0 | D6 | D5 | D4 | D3 | D2 | D1 | D0 | | Scroll towards SEG0 with 1 column offset |
| 1 | E[1:0] | 0 | 0 | 0 | 0 | 0 | 0 | E1 | E0 | | B[6:0] : start row address |
| | | | | | | | | | | | C[7:0] : end row address |
| | | | | | | | | | | | D[6:0] : Reserved (reset=00h) |
| | | | | | | | | | | | E[1:0] : scrolling time interval |
| | | | | | | | | | | | 00b Invalid |
| | | | | | | | | | | | 01b normal |
| | | | | | | | | | | | 10b slow |
| | | | | | | | | | | | 11b slowest |
| | | | | | | | | | | | Note Operates during display ON. |
| 0 | 9E | 1 | 0 | 0 | 1 | 1 | 1 | 1 | 0 | Stop Moving | Stop horizontal scroll |
| | | | | | | | | | | | Note After sending 9Eh command to stop the scrolling action, the ram data needs to be rewritten |
| 0 | 9F | 1 | 0 | 0 | 1 | 1 | 1 | 1 | 1 | Start Moving | Start horizontal scroll |

Note

(2) "*" stands for "Don't care".

7. Optical Characteristics

| Item | Symbol | Condition | Min | Typ | Max | Unit |
|---|--------------|-----------|--------|------|------|-------------------|
| View Angle | (V) θ | — | 160 | — | — | deg |
| | (H) ϕ | — | 160 | — | — | deg |
| Contrast Ratio | CR | Dark | 2000:1 | — | — | — |
| Response Time | T rise | — | — | 10 | — | μ s |
| | T fall | — | — | 10 | — | μ s |
| Display with 50% check Board Brightness | | | 60 | 80 | — | cd/m ² |
| CIEx(Yellow) | | (CIE1931) | 0.45 | 0.47 | 0.49 | — |
| CIEy(Yellow) | | (CIE1931) | 0.48 | 0.50 | 0.52 | — |

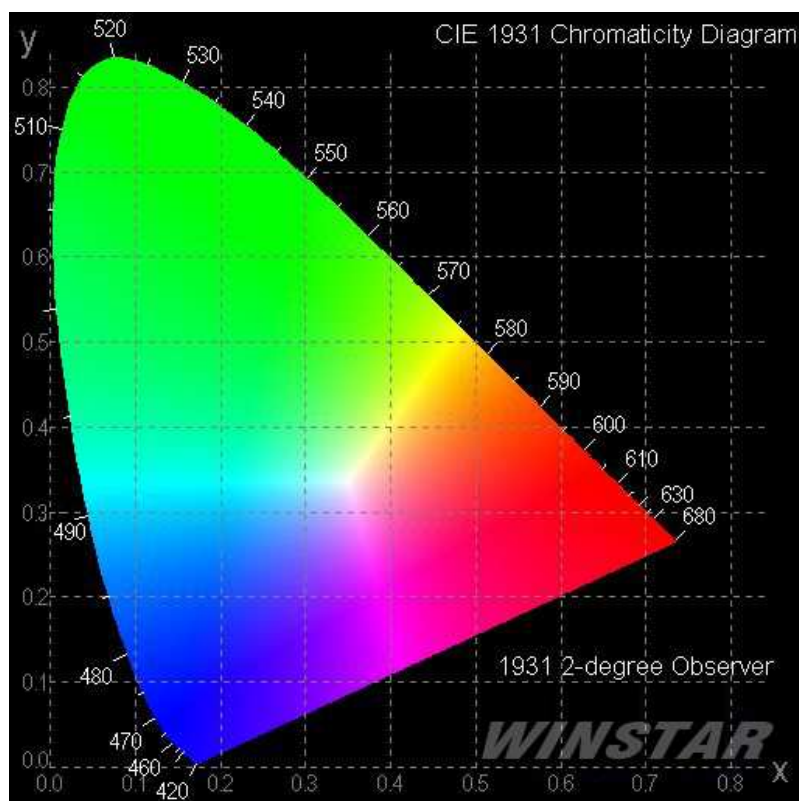

8.OLED Lifetime

| ITEM | Conditions | Min | Typ | Remark |
|---------------------|--|------------|-----|--------|
| Operating Life Time | Ta=25°C / Initial 50% check board brightness Typical Value | 50,000 Hrs | — | Note |

Notes:

1. Life time is defined the amount of time when the luminance has decayed to <50% of the initial value.
2. This analysis method uses life data obtained under accelerated conditions to extrapolate an estimated probability density function (*pdf*) for the product under normal use conditions.
3. Screen saving mode will extend OLED lifetime.

9. Reliability

Content of Reliability Test

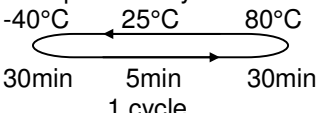
| Environmental Test | | | |
|--------------------------------------|--|---|---------------------|
| Test Item | Content of Test | Test Condition | Applicable Standard |
| High Temperature storage | Endurance test applying the high storage temperature for a long time. | 85°C 240hrs | — |
| Low Temperature storage | Endurance test applying the low storage temperature for a long time. | -40°C 240hrs | — |
| High Temperature Operation | Endurance test applying the electric stress (Voltage & Current) and the thermal stress to the element for a long time. | 80°C 240hrs | — |
| Low Temperature Operation | Endurance test applying the electric stress under low temperature for a long time. | -40°C 240hrs | — |
| High Temperature/ Humidity Storage | Endurance test applying the high temperature and high humidity storage for a long time. | 60°C, 90%RH 240hrs | — |
| High Temperature/ Humidity Operation | Endurance test applying the high temperature and high humidity Operation for a long time. | 60°C, 90%RH 120hrs | — |
| Temperature Cycle | Endurance test applying the low and high temperature cycle.  | -40°C / 80°C 30 cycles | — |
| Mechanical Test | | | |
| Vibration test | Endurance test applying the vibration during transportation and using. | Frequency: 10~55Hz amplitude: 1.5mm Time: 0.5hrs/axis Test axis: X, Y, Z | — |
| Others | | | |
| Static electricity test | Endurance test applying the electric stress to the finished product housing. | Air Discharge model ±4kv, 10 times | — |

*** Supply voltage for OLED system = Operating voltage at 25°C

Test and measurement conditions

1. All measurements shall not be started until the specimens attain to temperature stability. After the completion of the described reliability test, the samples were left at room temperature for 2 hrs prior to conducting the failure test at $23\pm 5^{\circ}\text{C}$; $55\pm 15\%$ RH.
2. All-pixels on/off exchange is used as operation test pattern.
3. The degradation of Polarizer are ignored for High Temperature storage, High Temperature/ Humidity Storage, Temperature Cycle

Evaluation criteria

1. The function test is OK.
2. No observable defects.
3. Luminance: $> 50\%$ of initial value.
4. Current consumption: within $\pm 50\%$ of initial value.

APPENDIX:**RESIDUE IMAGE**

Because the pixels are lighted in different time, the luminance of active pixels may reduce or differ from inactive pixels. Therefore, the residue image will occur. To avoid the residue image, every pixel needs to be lighted up uniformly.

10. Inspection specification

Inspection Standard:

MIL-STD-105E table normal inspection single sample level II.

Definition

1 Major defect : The defect that greatly affect the usability of product.

2 Minor defect : The other defects, such as cosmetic defects, etc.

Definition of inspection zone:

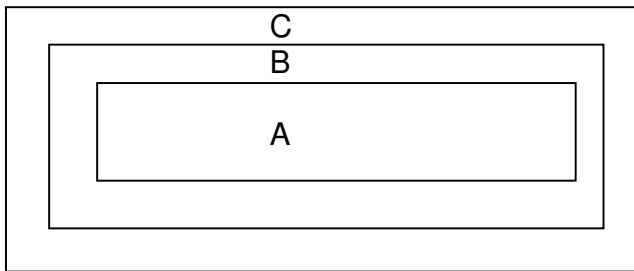

Zone A: Active Area

Zone B: Viewing Area except Zone A

Zone C: Outside Viewing Area

Note: As a general rule, visual defects in Zone C are permissible, when it is no trouble of quality and assembly to customer`s product.

Inspection Methods

1 The general inspection : Under fluorescent light illumination: 750~1500 Lux, about 30cm viewing distance, within 45° viewing angle, under 25±5°C.

2 The luminance and color coordinate inspection : By SR-3 or BM-7 or the equal equipments, in the dark room, under 25±5°C.

| NO | Item | Criterion | AQL |
|----|---|---|------|
| 01 | Electrical Testing | 1.1 Missing vertical, horizontal segment, segment contrast defect. 1.2 Missing character , dot or icon. 1.3 Display malfunction. 1.4 No function or no display. 1.5 Current consumption exceeds product specifications. 1.6 OLED viewing angle defect. 1.7 Mixed product types. 1.8 Contrast defect. | 0.65 |
| 02 | Black or white spots on OLED (display only) | 2.1 White and black spots on display $\leq 0.25\text{mm}$, no more than three white or black spots present. 2.2 Densely spaced: No more than two spots or lines within 3mm. | 2.5 |

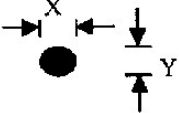
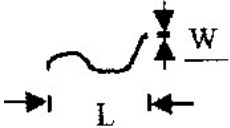
| NO | Item | Criterion | AQL | | | | | | | | | | | | | | | | | | | |
|-------------------------|--|--|-------------|----------------|----------------|------------------|--------|---------------|-------------------------|-----|--------------|-------------------------|---|------|---------------|----------------------|------|-----------|------------|---------------|-----|-----|
| 03 | OLED black spots, white spots, contamination (non-display) | 3.1 Round type : As following drawing $\Phi = (x + y) / 2$  <table border="1" data-bbox="711 367 1362 573"> <thead> <tr> <th>SIZE</th> <th>Acceptable QTY</th> <th>Zone</th> </tr> </thead> <tbody> <tr> <td>$\Phi \leq 0.10$</td> <td>ignore</td> <td>A+ B,</td> </tr> <tr> <td>$0.10 < \Phi \leq 0.20$</td> <td>2</td> <td>A+ B</td> </tr> <tr> <td>$0.20 < \Phi \leq 0.25$</td> <td>1</td> <td>A+ B</td> </tr> <tr> <td>$0.25 < \Phi$</td> <td>0</td> <td>A+ B</td> </tr> </tbody> </table> | SIZE | Acceptable QTY | Zone | $\Phi \leq 0.10$ | ignore | A+ B, | $0.10 < \Phi \leq 0.20$ | 2 | A+ B | $0.20 < \Phi \leq 0.25$ | 1 | A+ B | $0.25 < \Phi$ | 0 | A+ B | 2.5 | | | | |
| | SIZE | Acceptable QTY | Zone | | | | | | | | | | | | | | | | | | | |
| $\Phi \leq 0.10$ | ignore | A+ B, | | | | | | | | | | | | | | | | | | | | |
| $0.10 < \Phi \leq 0.20$ | 2 | A+ B | | | | | | | | | | | | | | | | | | | | |
| $0.20 < \Phi \leq 0.25$ | 1 | A+ B | | | | | | | | | | | | | | | | | | | | |
| $0.25 < \Phi$ | 0 | A+ B | | | | | | | | | | | | | | | | | | | | |
| | | 3.2 Line type : (As following drawing)  <table border="1" data-bbox="584 958 1362 1200"> <thead> <tr> <th>Length</th> <th>Width</th> <th>Acceptable QTY</th> <th>Zone</th> </tr> </thead> <tbody> <tr> <td>---</td> <td>$W \leq 0.02$</td> <td>ignore</td> <td>A+B</td> </tr> <tr> <td>$L \leq 3.0$</td> <td>$0.02 < W \leq 0.03$</td> <td rowspan="2">2</td> <td>A+B</td> </tr> <tr> <td>$L \leq 2.5$</td> <td>$0.03 < W \leq 0.05$</td> <td>A+B</td> </tr> <tr> <td>---</td> <td>$0.05 < W$</td> <td>As round type</td> <td></td> </tr> </tbody> </table> | Length | Width | Acceptable QTY | Zone | --- | $W \leq 0.02$ | ignore | A+B | $L \leq 3.0$ | $0.02 < W \leq 0.03$ | 2 | A+B | $L \leq 2.5$ | $0.03 < W \leq 0.05$ | A+B | --- | $0.05 < W$ | As round type | | 2.5 |
| Length | Width | Acceptable QTY | Zone | | | | | | | | | | | | | | | | | | | |
| --- | $W \leq 0.02$ | ignore | A+B | | | | | | | | | | | | | | | | | | | |
| $L \leq 3.0$ | $0.02 < W \leq 0.03$ | 2 | A+B | | | | | | | | | | | | | | | | | | | |
| $L \leq 2.5$ | $0.03 < W \leq 0.05$ | | A+B | | | | | | | | | | | | | | | | | | | |
| --- | $0.05 < W$ | As round type | | | | | | | | | | | | | | | | | | | | |
| 04 | Polarizer bubbles | If bubbles are visible, judge using black spot specifications, not easy to find, must check in specify direction. <table border="1" data-bbox="705 1352 1362 1594"> <thead> <tr> <th>Size Φ</th> <th>Acceptable QTY</th> <th>Zone</th> </tr> </thead> <tbody> <tr> <td>$\Phi \leq 0.20$</td> <td>ignore</td> <td>A+B</td> </tr> <tr> <td>$0.20 < \Phi \leq 0.50$</td> <td>3</td> <td>A+B</td> </tr> <tr> <td>$0.50 < \Phi \leq 1.00$</td> <td>2</td> <td>A+B</td> </tr> <tr> <td>$1.00 < \Phi$</td> <td>0</td> <td>A+B</td> </tr> <tr> <td>Total QTY</td> <td>3</td> <td></td> </tr> </tbody> </table> | Size Φ | Acceptable QTY | Zone | $\Phi \leq 0.20$ | ignore | A+B | $0.20 < \Phi \leq 0.50$ | 3 | A+B | $0.50 < \Phi \leq 1.00$ | 2 | A+B | $1.00 < \Phi$ | 0 | A+B | Total QTY | 3 | | 2.5 | |
| Size Φ | Acceptable QTY | Zone | | | | | | | | | | | | | | | | | | | | |
| $\Phi \leq 0.20$ | ignore | A+B | | | | | | | | | | | | | | | | | | | | |
| $0.20 < \Phi \leq 0.50$ | 3 | A+B | | | | | | | | | | | | | | | | | | | | |
| $0.50 < \Phi \leq 1.00$ | 2 | A+B | | | | | | | | | | | | | | | | | | | | |
| $1.00 < \Phi$ | 0 | A+B | | | | | | | | | | | | | | | | | | | | |
| Total QTY | 3 | | | | | | | | | | | | | | | | | | | | | |
| 05 | Scratches | Follow NO.3 OLED black spots, white spots, contamination. | | | | | | | | | | | | | | | | | | | | |

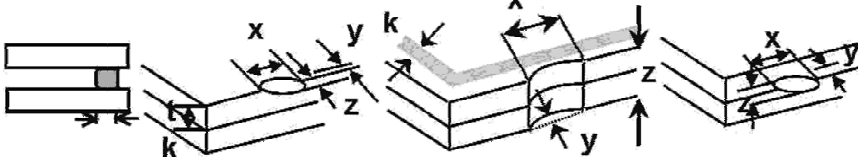
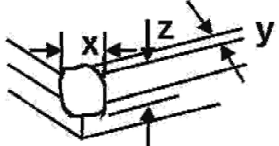
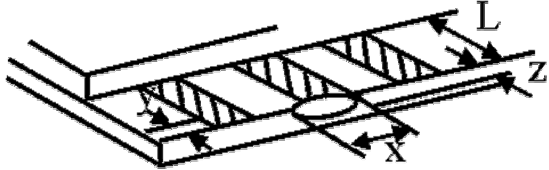
| NO | Item | Criterion | AQL | | | | | | | | | | | | | | | | | | |
|-----------------------|-----------------------|--|-------------------|----------------|-------------------|-----------------------|-----------------------|----------------|--------------------|-----------------|---------------|-------------------|---------------|----------------|---------------|-----------------------|---------------|--------------------|-----------------|---------------|-----|
| 06 | Chipped glass | <p>Symbols Define: x: Chip length y: Chip width z: Chip thickness k: Seal width t: Glass thickness a: OLED side length L: Electrode pad length: 6.1 General glass chip : 6.1.1 Chip on panel surface and crack between panels:</p>  <table border="1" data-bbox="454 660 1340 784"> <thead> <tr> <th>z: Chip thickness</th> <th>y: Chip width</th> <th>x: Chip length</th> </tr> </thead> <tbody> <tr> <td>$Z \leq 1/2t$</td> <td>Not over viewing area</td> <td>$x \leq 1/8a$</td> </tr> <tr> <td>$1/2t < z \leq 2t$</td> <td>Not exceed 1/3k</td> <td>$x \leq 1/8a$</td> </tr> </tbody> </table> <p>⊙ If there are 2 or more chips, x is total length of each chip.</p> <p>6.1.2 Corner crack:</p>  <table border="1" data-bbox="454 1041 1356 1164"> <thead> <tr> <th>z: Chip thickness</th> <th>y: Chip width</th> <th>x: Chip length</th> </tr> </thead> <tbody> <tr> <td>$Z \leq 1/2t$</td> <td>Not over viewing area</td> <td>$x \leq 1/8a$</td> </tr> <tr> <td>$1/2t < z \leq 2t$</td> <td>Not exceed 1/3k</td> <td>$x \leq 1/8a$</td> </tr> </tbody> </table> <p>⊙ If there are 2 or more chips, x is the total length of each chip.</p> | z: Chip thickness | y: Chip width | x: Chip length | $Z \leq 1/2t$ | Not over viewing area | $x \leq 1/8a$ | $1/2t < z \leq 2t$ | Not exceed 1/3k | $x \leq 1/8a$ | z: Chip thickness | y: Chip width | x: Chip length | $Z \leq 1/2t$ | Not over viewing area | $x \leq 1/8a$ | $1/2t < z \leq 2t$ | Not exceed 1/3k | $x \leq 1/8a$ | 2.5 |
| z: Chip thickness | y: Chip width | x: Chip length | | | | | | | | | | | | | | | | | | | |
| $Z \leq 1/2t$ | Not over viewing area | $x \leq 1/8a$ | | | | | | | | | | | | | | | | | | | |
| $1/2t < z \leq 2t$ | Not exceed 1/3k | $x \leq 1/8a$ | | | | | | | | | | | | | | | | | | | |
| z: Chip thickness | y: Chip width | x: Chip length | | | | | | | | | | | | | | | | | | | |
| $Z \leq 1/2t$ | Not over viewing area | $x \leq 1/8a$ | | | | | | | | | | | | | | | | | | | |
| $1/2t < z \leq 2t$ | Not exceed 1/3k | $x \leq 1/8a$ | | | | | | | | | | | | | | | | | | | |
| 06 | Glass crack | <p>Symbols : x: Chip length y: Chip width z: Chip thickness k: Seal width t: Glass thickness a: OLED side length L: Electrode pad length 6.2 Protrusion over terminal : 6.2.1 Chip on electrode pad :</p>  <table border="1" data-bbox="454 1691 1340 1780"> <thead> <tr> <th>y: Chip width</th> <th>x: Chip length</th> <th>z: Chip thickness</th> </tr> </thead> <tbody> <tr> <td>$y \leq 0.5\text{mm}$</td> <td>$x \leq 1/8a$</td> <td>$0 < z \leq t$</td> </tr> </tbody> </table> | y: Chip width | x: Chip length | z: Chip thickness | $y \leq 0.5\text{mm}$ | $x \leq 1/8a$ | $0 < z \leq t$ | 2.5 | | | | | | | | | | | | |
| y: Chip width | x: Chip length | z: Chip thickness | | | | | | | | | | | | | | | | | | | |
| $y \leq 0.5\text{mm}$ | $x \leq 1/8a$ | $0 < z \leq t$ | | | | | | | | | | | | | | | | | | | |

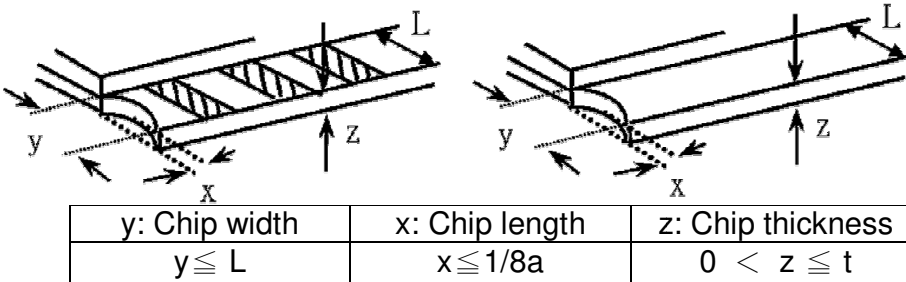
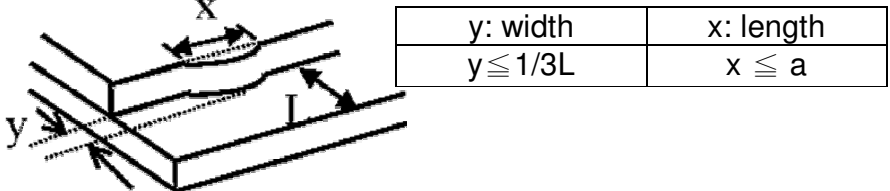
| NO | Item | Criterion | AQL |
|----|--------------------|--|---|
| 06 | Glass crack | <p>6.2.2 Non-conductive portion:</p>  <p>○ If the chipped area touches the ITO terminal, over 2/3 of the ITO must remain and be inspected according to electrode terminal specifications.</p> <p>○ If the product will be heat sealed by the customer, the alignment mark not be damaged.</p> <p>6.2.3 Substrate protuberance and internal crack.</p>  | 2.5 |
| 07 | Cracked glass | The OLED with extensive crack is not acceptable. | 2.5 |
| 08 | Backlight elements | <p>8.1 Illumination source flickers when lit.</p> <p>8.2 Spots or scratched that appear when lit must be judged. Using OLED spot, lines and contamination standards.</p> <p>8.3 Backlight doesn't light or color wrong.</p> | 0.65 2.5 0.65 |
| 09 | Bezel | <p>9.1 Bezel may not have rust, be deformed or have fingerprints, stains or other contamination.</p> <p>9.2 Bezel must comply with job specifications.</p> | 2.5 0.65 |
| 10 | PCB , COB | <p>10.1 COB seal may not have pinholes larger than 0.2mm or contamination.</p> <p>10.2 COB seal surface may not have pinholes through to the IC.</p> <p>10.3 The height of the COB should not exceed the height indicated in the assembly diagram.</p> <p>10.4 There may not be more than 2mm of sealant outside the seal area on the PCB. And there should be no more than three places.</p> <p>10.5 No oxidation or contamination PCB terminals.</p> <p>10.6 Parts on PCB must be the same as on the production characteristic chart. There should be no wrong parts, missing parts or excess parts.</p> <p>10.7 The jumper on the PCB should conform to the product characteristic chart.</p> <p>10.8 If solder gets on bezel tab pads, OLED pad, zebra pad or screw hold pad, make sure it is smoothed down.</p> | 2.5 2.5 0.65 2.5 2.5 0.65 0.65 2.5 |

| NO | Item | Criterion | AQL |
|----|--------------------|---|--------------|
| 11 | Soldering | 11.1 No un-melted solder paste may be present on the PCB. | 2.5 |
| | | 11.2 No cold solder joints, missing solder connections, oxidation or icicle. | 2.5 |
| | | 11.3 No residue or solder balls on PCB. | 2.5 |
| | | 11.4 No short circuits in components on PCB. | 0.65 |
| 12 | General appearance | 12.1 No oxidation, contamination, curves or, bends on interface Pin (OLB) of TCP. | 2.5 |
| | | 12.2 No cracks on interface pin (OLB) of TCP. | 0.65 |
| | | 12.3 No contamination, solder residue or solder balls on product. | 2.5 |
| | | 12.4 The IC on the TCP may not be damaged, circuits. | |
| | | 12.5 The uppermost edge of the protective strip on the interface pin must be present or look as if it cause the interface pin to sever. | 2.5 2.5 |
| | | 12.6 The residual rosin or tin oil of soldering (component or chip component) is not burned into brown or black color. | 2.5 |
| | | 12.7 Sealant on top of the ITO circuit has not hardened. | |
| | | 12.8 Pin type must match type in specification sheet. | 2.5 |
| | | 12.9 OLED pin loose or missing pins. | 0.65 |
| | | 12.10 Product packaging must the same as specified on packaging specification sheet. | 0.65 0.65 |
| | | 12.11 Product dimension and structure must conform to product specification sheet. | 0.65 |

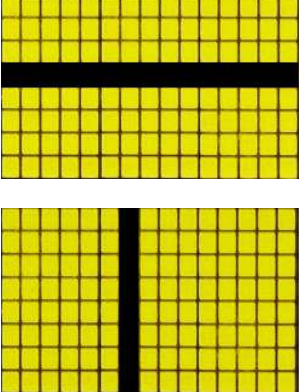
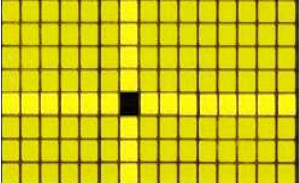
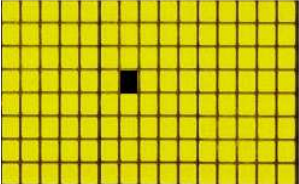
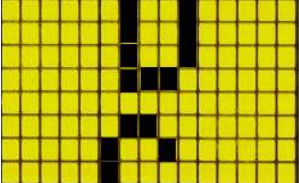
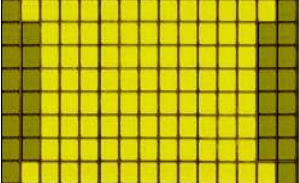
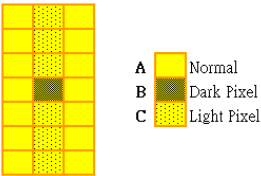
| Check Item | Classification | Criteria |
|--|----------------|--|
| No Display | Major |  |
| Missing Line | Major |  |
| Pixel Short | Major |  |
| Darker Short | Major |  |
| Wrong Display | Major |  |
| Un-uniform $B/A \times 100\% < 70\%$ $A/C \times 100\% < 70\%$ | Major |  <div data-bbox="866 1626 1166 1823">  <p> A Normal B Dark Pixel C Light Pixel </p> </div> |

11. Precautions in use of OLED Modules

Modules

- (1) Avoid applying excessive shocks to module or making any alterations or modifications to it.
- (2) Don't make extra holes on the printed circuit board, change the components or modify its shape of OLED display module.
- (3) Don't disassemble the OLED display module.
- (4) Do not apply input signals while the logic power is off.
- (5) Don't operate it above the absolute maximum rating.
- (6) Don't drop, bend or twist OLED display module.
- (7) Soldering: only to the I/O terminals.
- (8) Hot-Bar FPC soldering condition: 280~350C, less than 5 seconds.
- (9) Winstar has the right to change the passive components (Resistors, capacitors and other passive components will have different appearance and color caused by the different supplier.) and change the PCB Rev. (In order to satisfy the supplying stability, management optimization and the best product performance...etc, under the premise of not affecting the electrical characteristics and external dimensions, Winstar have the right to modify the version.)
- (10) Winstar has the right to upgrade or modify the product function.

11.1. Handling Precautions

- (1) Since the display panel is being made of glass, do not apply mechanical impacts such as dropping from a high position.
- (2) If the display panel is broken by some accident and the internal organic substance leaks out, be careful not to inhale nor lick the organic substance.
- (3) If pressure is applied to the display surface or its neighborhood of the OLED display module, the cell structure may be damaged. So, be careful not to apply pressure to these sections.
- (4) The polarizer covering the surface of the OLED display module is soft and easily scratched.
- (5) When the surface of the polarizer of the OLED display module has soil, clean the surface. It takes advantage by using following adhesion tape.
 - * Scotch Mending Tape No. 810 or an equivalentNever try to breathe upon the soiled surface nor wipe the surface using cloth containing solvent such as ethyl alcohol, since the surface of the polarizer will become cloudy. Also, pay attention that the following liquid and solvent may spoil the polarizer:
 - * Water
 - * Ketone
 - * Aromatic Solvents
- (6) Protection film is being applied to the surface of the display panel and removes the protection film before assembling it. At this time, if the OLED display module has been stored for a long period of time, residue adhesive material of the protection film may remain on the surface of the display panel after removed of the film. In such case, remove the residue material by the method introduced in the above Section 5.
- (7) Do not touch the following sections whenever possible while handling the OLED display modules.
 - * Pins and electrodes
 - * Pattern layouts such as the TCP & FPC
- (8) Hold OLED display module very carefully when placing OLED display module into the System housing. Do not apply excessive stress or pressure to OLED display module. And, do not over bend the film with electrode pattern layouts. These stresses will influence the display performance. Also, secure sufficient rigidity for the outer cases.

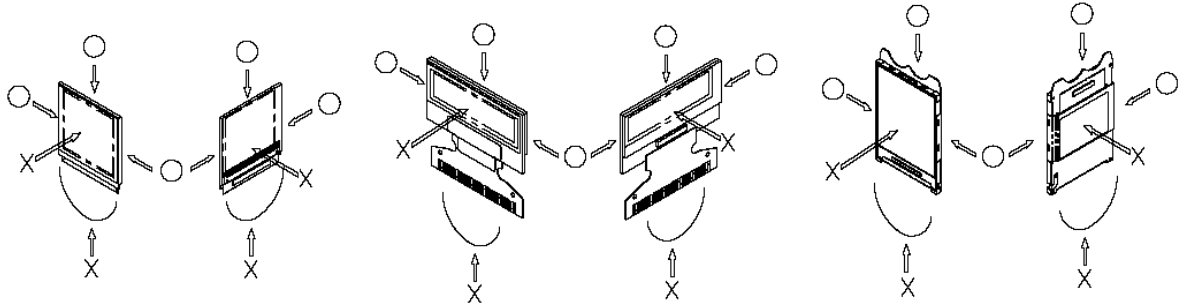

- (9) Do not apply stress to the LSI chips and the surrounding molded sections.
- (10) Pay sufficient attention to the working environments when handing OLED display modules to prevent occurrence of element breakage accidents by static electricity.
 - * Be sure to make human body grounding when handling OLED display modules.
 - * Be sure to ground tools to use or assembly such as soldering irons.
 - * To suppress generation of static electricity, avoid carrying out assembly work under dry environments.
 - * Protective film is being applied to the surface of the display panel of the OLED display module. Be careful since static electricity may be generated when exfoliating the protective film.

11.2. Storage Precautions

- (1) When storing OLED display modules, put them in static electricity preventive bags to avoid be directly exposed to sun or lights of fluorescent lamps. (We recommend you to store these modules in the packaged state when they were shipped from Winstar. At that time, be careful not to let water drops adhere to the packages or bags.)
- (2) When the OLED display module is being dewed or when it is placed under high temperature or high humidity environments, the electrodes may be corroded if electric current is applied. Please store it in clean environment.

11.3. Designing Precautions

- (1) The absolute maximum ratings are the ratings which cannot be exceeded for OLED display module, and if these values are exceeded, OLED display module may be damaged.
- (2) To prevent occurrence of malfunctioning by noise, pay attention to satisfy the VIL and VIH specification and to make the signal line cable as short as possible.
- (3) We recommend you to install excess current preventive unit (fuses, etc.) to the power circuit (VDD / VCC). (Recommend value: 0.5A)
- (4) Pay sufficient attention to avoid occurrence of mutual noise interference with the nearby devices.
- (5) As for EMI, take necessary measures on the equipment side basically.
- (6) If the power supplied to the OLED display module is forcibly shut down by such errors as taking out the main battery while the OLED display panel is in operation, we cannot guarantee the quality of this OLED display module.
 - * Connection (contact) to any other potential than the above may lead to rupture of the IC.
- (7) If this OLED driver is exposed to light, malfunctioning may occur and semiconductor elements may change their characteristics.
- (8) The internal status may be changed, if excessive external noise enters into the module. Therefore, it is necessary to take appropriate measures to suppress noise generation or to protect module from influences of noise on the system design.
- (9) We recommend you to make periodical refreshment of the operation statuses (re-setting of the commands and re-transference of the display data) to cope with catastrophic noise.

- (10) It's pretty common to use "Screen Saver" to extend the lifetime and Don't use the same image for long time in real application. When an OLED display module is operated for a long of time with fixed pattern, an afterimage or slight contrast deviation may occur.
- (11) The limitation of FPC and Film bending.

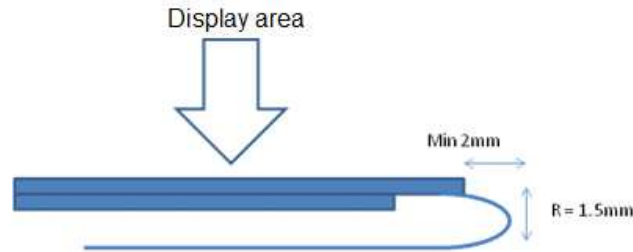

- (12) The module should be fixed balanced into the housing, or the module may be twisted.

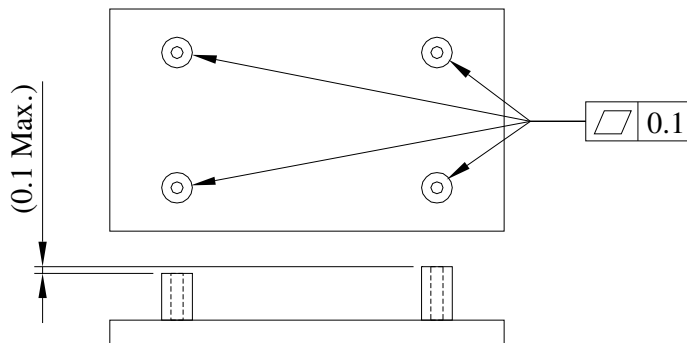

- (13) Please heat up a little the tape sticking on the components when removing it; otherwise the components might be damaged.

11.4. Precautions when disposing of the OLED display modules

- (1) Request the qualified companies to handle industrial wastes when disposing of the OLED display modules. Or, when burning them, be sure to observe the environmental and hygienic laws and regulations.