

# SLLP-5630-150-B

## Table of Contents

Features.....	1
Applications.....	1
Characteristics.....	1
Typical Electro-optical Characteristics Curves.....	3
Mechanical Dimensions.....	4
Carrier Tape Dimensions.....	5
Reel Specification.....	5
Reliability.....	6
Recommended Soldering Profile.....	7
Caution .....	9

**RoHS Compliant**

## Features

- Super high brightness surface mount LED
- Compatible with Automatic Placement Machine
- Pb free & RoHS compliant product
- Class 1 ESD sensitive

## Applications

- Automotive Lighting
- Indoor and Outdoor Displays
- Backlighting (LCD, Displays, Switches, Office Equipment)
- Indicator
- General Use

## Characteristics

### Absolute Maximum Ratings (TA=25°C)

Parameter	Symbol	MAX.	Unit
Average Forward Current <sup>[a] [c]</sup>	$I_F$	150	mA
Peak Forward Current <sup>[b]</sup>	$I_{peak}$	300	mA
Reverse Voltage	$V_R$	5	V
Power Dissipation	$P_D$	547.5	mW
LED Junction Temperature	$T_J$	125	°C
Operation Temperature Range <sup>[c]</sup>	$T_{OPR}$	-40~+100°C	
Storage Temperature Range	$T_{STO}$	-40~+100°C	
Lead Soldering Condition	$T_{SOL}$	260°/5 seconds	

Note: [a] Design of heat dissipation should be considered.

[b] Duty Ratio = 1/10, Pulse Width = 0.1ms

[c] The allowable operating current at different operation temperature, please take reference from Fig. 4 page 3.

Device Selection Guide (Optical Characteristics at  $T_A=25^\circ\text{C}$ )

Part Number	Driving Current $I_F(\text{mA})$	Luminous Flux $\Phi_V(\text{lm})$		Viewing Angle $2\theta_{1/2}$	Dominant Wavelength $\lambda_D(\text{nm})$	Forward Voltage $V_F(\text{V})$		$I_R(\mu\text{A})@V_R=5\text{V}$
		Min.	Typ.	Typ.	Typ.	Typ.	Max.	Max.
SLLP-5630-150-B	150	6.3	9	$120^\circ$	470	3.2	3.65	10

Notes: Total flux value is just for reference, and is a typical value.

## Electro-Optical Characteristics

Parameter	Symbol	Bin Code	Min	Max	Unit	Condition
Luminous Intensity	$\Phi_V$	0B	6.3	8.2	lm	$I_F=150\text{mA}$
		0C	8.2	10.7		
		0F	18.1	23.5		
		0G	23.5	30.6		
Forward Voltage	$V_F$	H	2.75	3.05	V	
		J	3.05	3.35		
		K	3.35	3.65		

Note:

1. Tolerance of measurement of luminous intensity:  $\pm 10\%$
2. Tolerance of measurement of forward voltage:  $\pm 0.1\text{V}$

## Intensity Distribution Table

Part Number	Emitting Color	Intensity Bin Code			
		0B	0C	0F	0G
SLLP-5630-150-B	Blue	●	●		

Note: [○] Bin with less distribution.

## Dominant Wavelength Bin Rank

Color	Dominant Wavelength $\lambda_D(\text{nm}) @ I_F=150\text{mA}$		
	min	max	Code
Blue	464	468	B1
	468	472	B2
	472	476	B3

Note: Tolerance of measurement of dominant wavelength:  $\pm 1.0\text{nm}$

## Typical Electro-Optical Characteristics Curves

(25°C Ambient Temperature Unless Otherwise Noted)

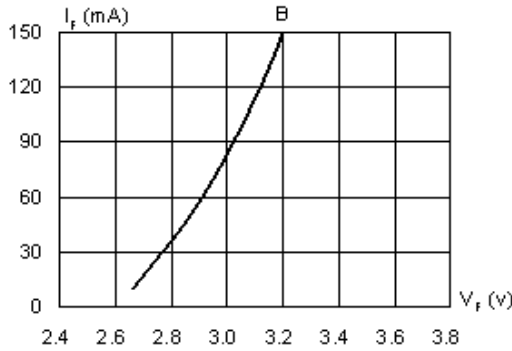

Fig.1 Forward Current vs. Forward Voltage

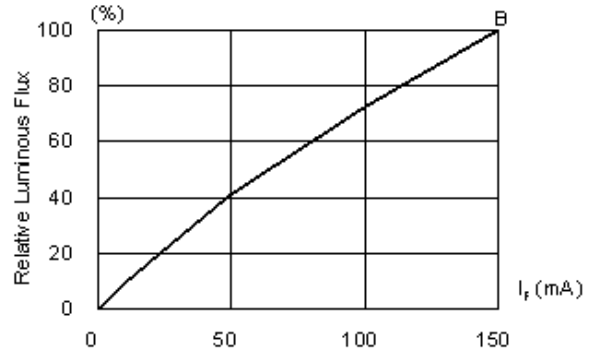

Fig.2 Luminous Intensity vs. Forward Current

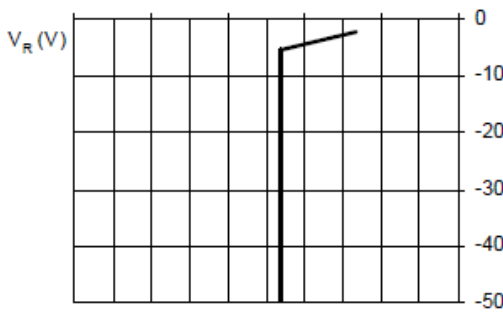

Fig.3 Reverse Current vs. Reverse Voltage

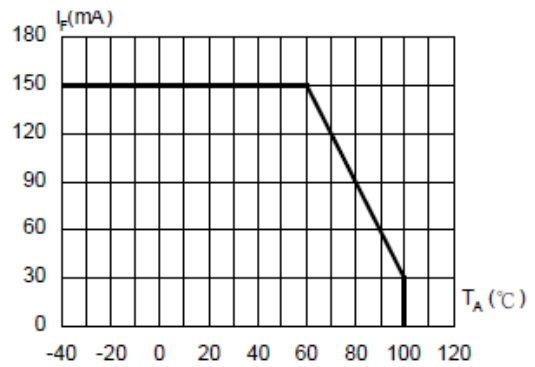

Fig.4 Allowable Forward Current vs. Ambient Temperature

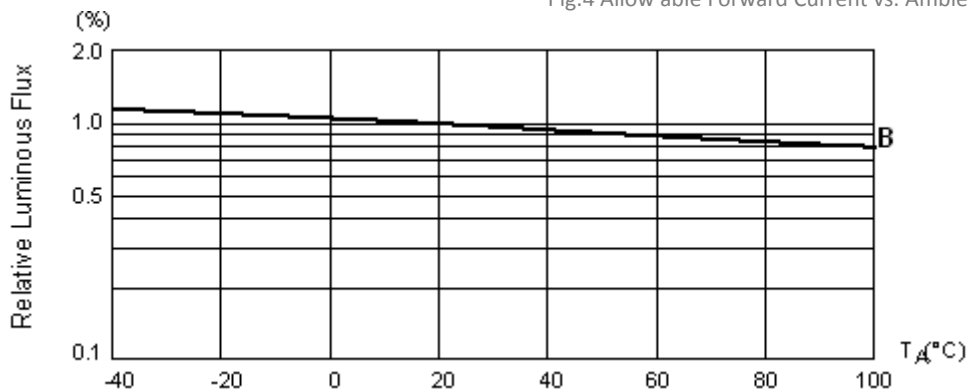

Fig.5 Luminous Intensity at I<sub>f</sub>=150Ma vs. Ambient Temperature

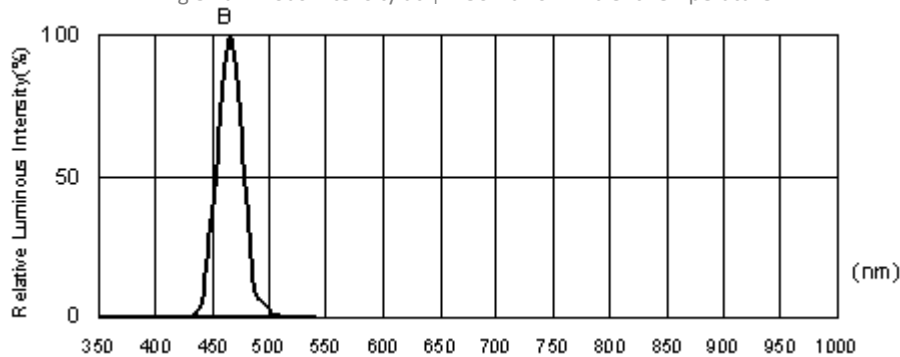
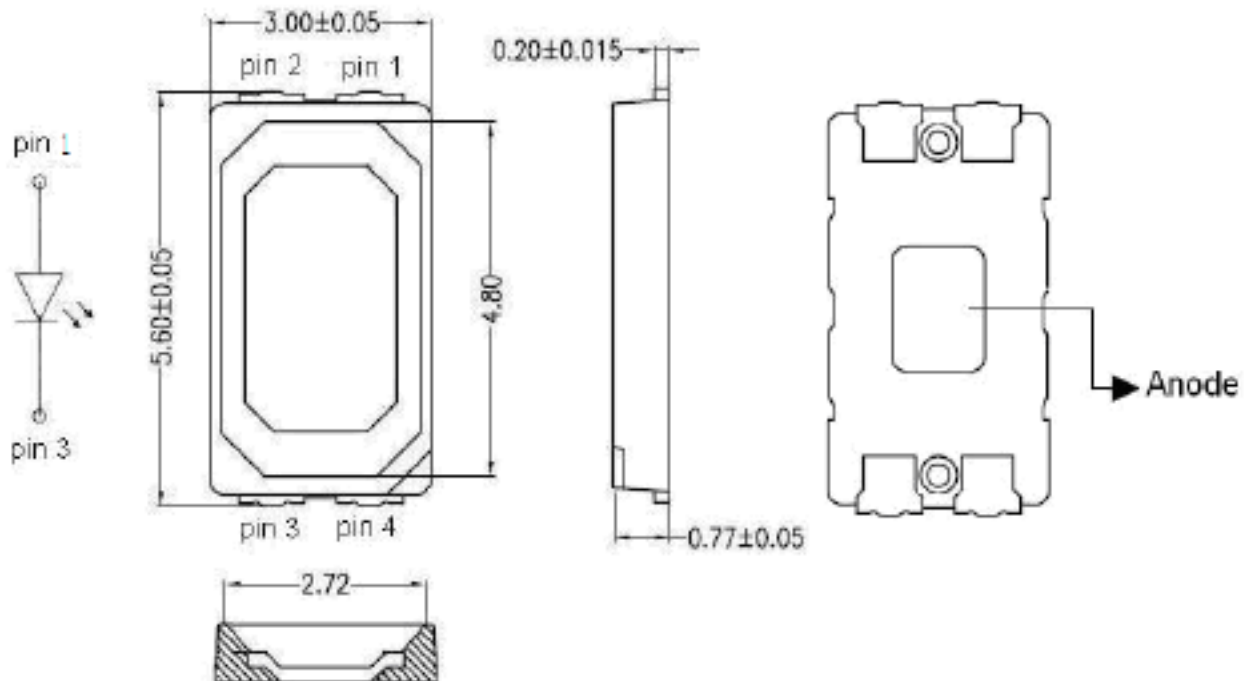

Fig.6 Relative Luminous Intensity vs. Wavelength

Note:

The data shown above are typical curves. Every LED component may have some variations of characteristics.

## Mechanical Dimensions



### Note:

1. All dimensions are in millimetre.
2. Tolerances is  $\pm 0.20$ mm unless otherwise note.
3. Specifications are subject to be changed without notice.

### Carrier Tape Dimensions

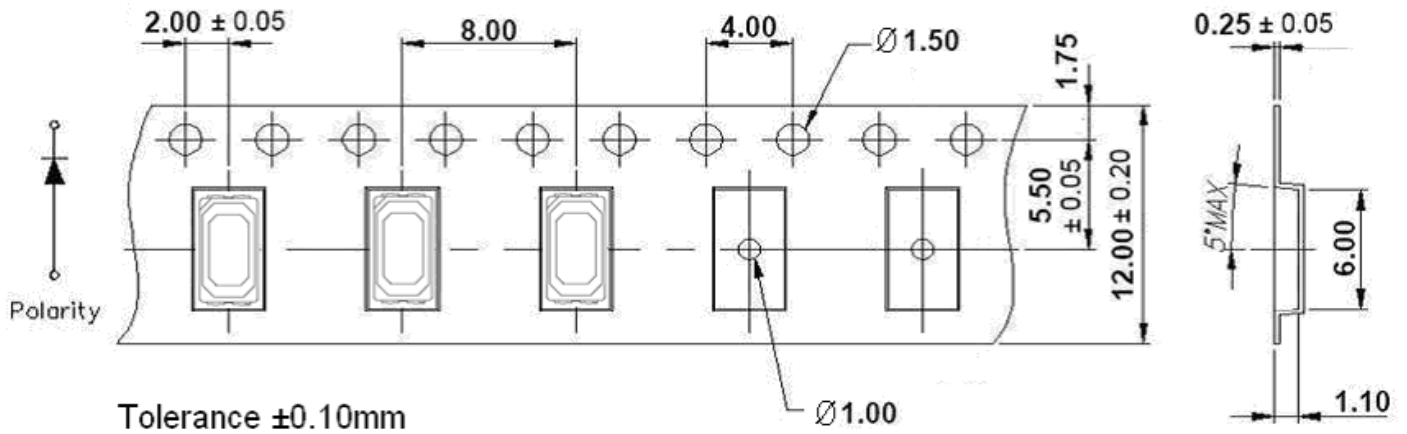

1. Polarity referring onto the cathode mark/line is reversed on the UR/HR(N-side up chips)
2. 1,500 pieces per reel is standard loading quantity.

### Reel Specification

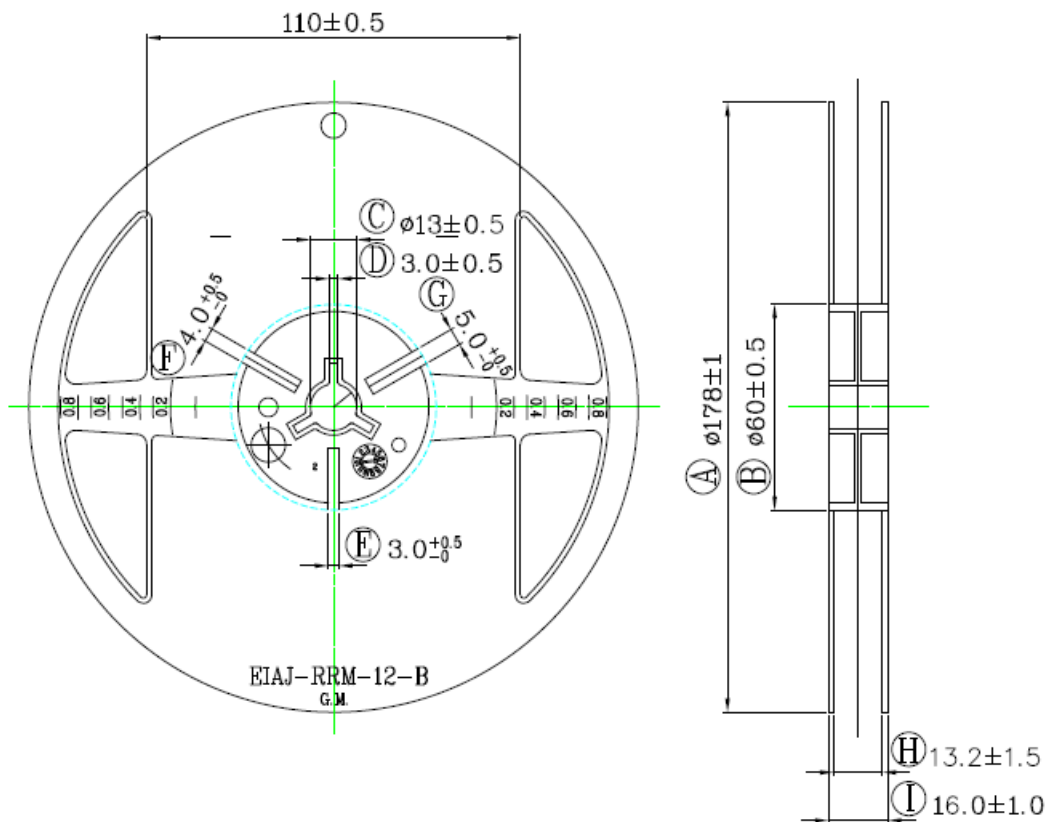

## Reliability Test Items and Results

LED components are checked by reliability test based on MIL standards.

Test Conditions, Acceptable Criteria & Results:

Classification	Test Item	Standard Test Method	Test Conditions	Duration	Unit	Acc/Rej Criteria	Result
Life Test	Operation Life Test	MIL-STD-750D Method 1026.3	TA=25°C; IF=150mA*	1000hrs	50pcs	0/1	pass
Environment Test	High Temperature Storage	MIL-STD-750D Method 1032.1	TA=100°C	1000hrs	50pcs	0/1	pass
	Low Temperature Storage	MIL-STD-750D Method 1032.1	TA=-40°C	1000hrs	50pcs	0/1	pass
	Temp& Humidity With Bias	MIL-STD-750D Method 103B	TA=85°C; Rh=85% IF=50mA**	1000hrs	50pcs	0/1	pass
	Thermal Shock	MIL-STD-750D Method 1056.1	0 °C (1min) ~100 °C (1min)	20cycles	50pcs	0/1	pass
	Temperature Cycling test	MIL-STD-750D Method 1051.5	-55°C (15min)~ 25°C (5min)~ 100°C (15min)~ 25°C (5min)	100cycles	50pcs	0/1	pass
Mechanical Test	Solder ability	MIL-STD-750D Method 2026.4	235±5°C; 3sec	1time	50pcs	0/1	pass
	Resistance to Soldering Heat	MIL-STD-750D Method 2031.1	260°C; 5sec	1time	50pcs	0/1	pass

### Failure Criteria

Test Item		Test Conditions	Criteria for Judgment	
			Min.	Max.
Luminous Intensity	I <sub>v</sub>	IF=150 mA	LSL x 0.5**	
Forward Voltage	V <sub>F</sub>	IF=150 mA		USL x 1.1*

## Recommended Soldering Profile

### Recommended Soldering Pad

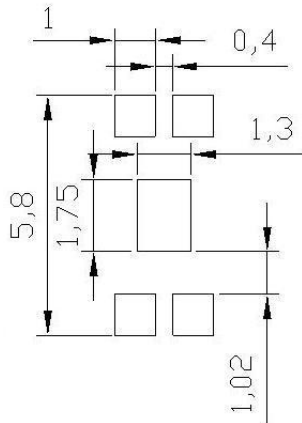

### Beam Pattern

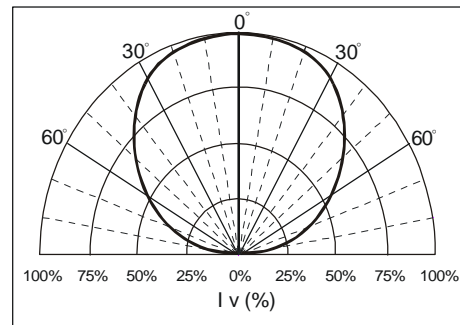

### Manual Soldering using Soldering Iron

The manual soldering process is not recommended for quality consideration. When it is absolutely necessary, the LEDs may be mounted in this fashion but the user will assume responsibility for any problems.

The following conditions are recommended:

- (1) Soldering material: SN60 (60% tin and 40% lead) solder or with silver content is recommended.
- (2) Temperature of the iron : lower than 300°C
- (3) Soldering time: maximum 3 seconds
- (4) Operation cautions:
  - Please avoid overheating of LED component in any process. Overheating may damage the LED package.
  - Please don't place any stress on the lens of LED, especially at high temperature

### Reflow Soldering

To prevent LED from cracking in reflow process, it's better to bake LED components before reflow soldering. After the package sealing bag is opened, please use the LED device as soon as possible to keep LED from moisture.

It's banned to load any stress on the resin during soldering. Please never take next process until the component is cooled down to room temperature after reflow. And, the manual soldering process is not recommended for quality consideration.

To ensure the performance of LED device, it is recommended to set up a reflow profile at lower temperature.

Recommended soldering paste specifications:

Contains: Sn 63%, Pb 37%(Melting temperature: 178~192°C)

The recommended reflow soldering profile (measure point is near the bottom of the LED package) is following:



**Figure 1:**  
Recommended Sn-Pb IR-Reflow Soldering Profile

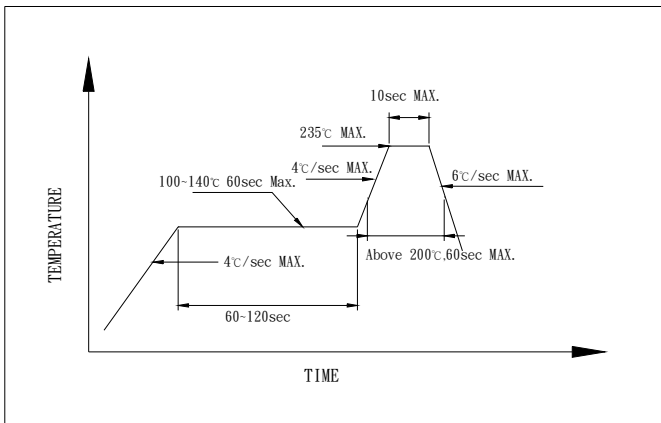

**Figure 2:**  
Recommended Pb-free Soldering Profile

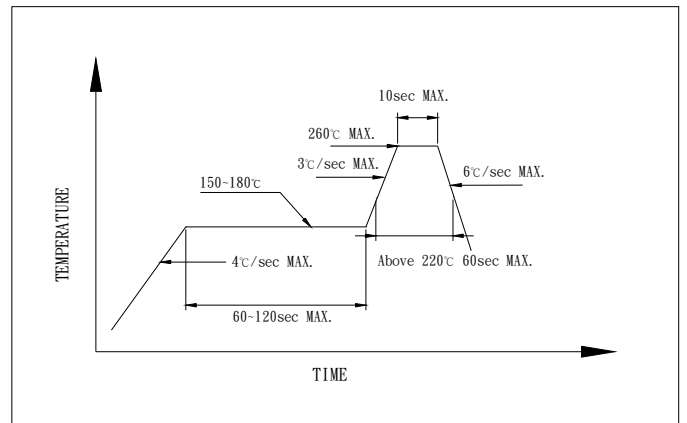

The soldering paste should be coated to the necessary area of soldering pads by the screen-printing or with the dispenser. In the case of the screen-printing, it is recommended to have the thickness of 0.2mm (0.0079 inch) to 0.3mm (0.0118 inch). The optimal thickness should be verified by pre-test, and will be different from every different layout of leads of LED.

Repairing should not be done after the LEDs have been soldered. When repairing is necessary, a double-head soldering iron should be used if the LED needs to be removed. Please refer to the recommendations for manual soldering iron if additional rework is needed.

## Caution

### Circuit layout

Due to the forward voltage of LED will vary with temperature and its driving current, the current-limited protective circuit should be considered in the LED circuit design.

When LEDs are arrayed as parallel circuit, different inherent resistance of LED will cause unbalance current. The unbalanced driving current which exists in every parallel circuit may make LED to be driven at different power. Therefore, the LED driven at higher power may be damaged by over driving current, and the LED driven at lower power may be dimmer than the others.

To solve this situation, a suitable resistor is recommended to put in series with each LED circuit.

The resistor will limit and balance the driving current which flows through every parallel circuits.

### Electric Static Discharge (ESD) Protection

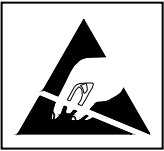

All kinds of LED materials, such as GaP, AlGaAs, AlInGaP, GaN, or InGaN chips, are STATIC SENSITIVE device. ESD protection or surge voltages shall be considered and taken care in the initial design stage, and whole production process.

The following protection is recommended:

- (1) A wrist band or an anti-electrostatic glove shall be used when handling the LEDs
- (2) All devices, equipment and machinery must be properly grounded

If LED is damaged by ESD or surge voltage, damaged LED may show some unusual characteristics. It may appear leakage current, and LED does not emit at low current.

And when using microscope to inspect damaged LED chip at low driving current, it may have some black dots within the emitting area.

### Dry Pack

SMD / PLCC device is a MOISTURE SENSITIVE device. Please keep LED from absorbing moisture at any time during transportation or storage. Every reel is packaged in the aluminum moisture barrier anti-static bag (Specific bag material will depend upon customer's requirement or option), and the bag is well sealed before shipment.

Silica gel material, which can absorb moisture, is also packed together with LED in package bag. And humidity indicator card act as an indicator, which informs users the condition of humidity within SMD package bag by change of color.

### The package is the following

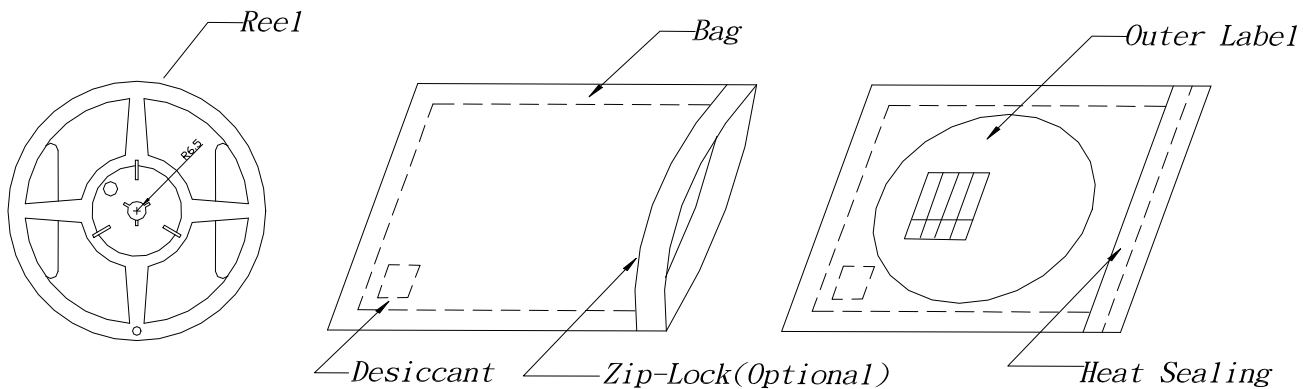

### Pick and Place

The following items should be paid attention in assembly process:

- (1) It should be avoided to load stress on the resin during pick and place process, especially at high temperature.
- (2) Avoid rubbing or scraping the resin by any object, and avoid leaving fingerprints on the lens.
- (3) Electric-static may cause damage to the component. Please confirm that the equipment is grounding well.
- (4) Some parts of PLCC series are using silicone material as encapsulation material. Silicone material is easily contaminated by particles. However a small amount of particles on the LEDs will not affect the brightness of the LEDs, and also the lifetime. Therefore, a small amount of particles on the surface of lens of LEDs can be ignored.

### Storage

It's recommended to store the products in the following conditions:

- (1) Shelf life in sealed bag: 12 months at  $T_A < 40^\circ\text{C}$  and Hum.  $< 60\%RH$ . (Base on aluminum laminated moisture barrier bag.)
- (2) After the package bag is opened and kept in the following environment, the LED products should be used completely as soon as possible:

Humidity (Hum.): 60%RH Max.

Temperature (TA):  $5^\circ\text{C} \sim 30^\circ\text{C}$  ( $41^\circ\text{F} \sim 86^\circ\text{F}$ )

Assembly duration: within 72 hours, after bag is opened.

If the some of LED are not used, they need to be kept at Hum.  $\leq 10\%RH$  in zip-locked sealed bags.

And if the duration exceeds 72 hours, re-baking process is required to keep LED from moisture.

Please avoid rapid transitions in ambient temperature, especially in high humidity environment where condensation can occur.

## Backing

It's recommended to bake before soldering. The conditions are suggested as followings:

- (1)  $60\pm 3^{\circ}\text{C}$  x (48~72hrs) and Hum. <1%RH for taped reel type
- (2)  $110\pm 3^{\circ}\text{C}$  x (2~3hrs) for bulk type

## Cleaning

An Alcohol-based solvent such as isopropyl alcohol (IPA) is recommended to clean the LED bulbs, after soldering process, if cleaning is necessary. Before cleaning, a pre-test should be done to confirm whether any damage to the LEDs will occur.

It is not recommended to use unspecified chemical liquids as cleaning material for cleaning the LED.

It's also not recommended to use ultrasonic power to clean the LED device. The chemical and ultrasonic power could harm the LED devices. The chemical and ultrasonic power could harm the LED devices.

## Application

- (1) The strong light from LEDs may injure human eyes. Precautions should be taken to prevent looking directly at the LEDs with unaided eyes.
- (2) In order to get maximum light output during the duration of LED's long life, designer should consider how to make excellent thermal dissipation when making the whole system design. It's recommended to avoid intense heat generation and to operate within the maximum ratings given in this approval sheets.
- (3) Every piece of LED will be sorted and LEDs with the same binning grade will be taped into the same reel or put into the same bag. It is recommended to use the same bin-grade LED to assembly the unit module. This will ensure the LED unit module with good uniformity of brightness, hue, and so on.

## About Us

**SemiLEDs Corporation** is a US based manufacturer of ultra-high brightness LED chips with state of the art fabrication facilities in Hsinchu Science Park, Taiwan. SemiLEDs specializes in the development and manufacturing of vertical LED chips in blue (white), green, and UV using a patented copper alloy base. This unique design allows for higher performance and longer lumen maintenance. The World Economic Forum recognized SemiLEDs innovations with the 2009 Technology Pioneer Award. SemiLEDs is fully ISO 9001:2008 Certified

SemiLEDs is a publicly traded company on NASDAQ Global Select Market (stock symbol "LEDS"). For investor information, please contact us at [investors@semileds.com](mailto:investors@semileds.com).

For further company or product information, please visit us at [www.semileds.com](http://www.semileds.com) or please contact [sales@semileds.com](mailto:sales@semileds.com).



[www.semileds.com](http://www.semileds.com)

### ASIA PACIFIC

3F, No. 11, KeJung Rd.

Chu-Nan Site

Hsinchu Science Park

Chu-Nan 350, Miao-Li County

Taiwan, ROC

Tel: +886-37-586788

Fax: +886-37-582688

[sales@semileds.com](mailto:sales@semileds.com)